



EUROPEAN PATENT APPLICATION

Application number : **92830550.7**

Int. Cl.⁵ : **H01H 1/00**

Date of filing : **01.10.92**

Priority : **15.11.91 IT MI913050**

Inventor : **Omati, Ennio, c/o MA-TER S.r.l.**
Via Torricelli, 14
I-22060 Pessano Con Bornago (MI) (IT)
 Inventor : **Omati, Marco, c/o MA-TER S.r.l.**
Via Torricelli, 14
I-22060 Pessano Con Bornago (MI) (IT)

Date of publication of application :
19.05.93 Bulletin 93/20

Designated Contracting States :
AT CH DE ES FR GB LI NL SE

Representative : **Cicogna, Franco**
Ufficio Internazionale Brevetti Dott.Prof.
Franco Cicogna Via Visconti di Modrone, 14/A
I-20122 Milano (IT)

Applicant : **MA-TER S.r.l.**
Via Torricelli, 14
I-20060 Pessano con Bornago, (Milano) (IT)

Pressure switch having a manually operated safety microswitch.

The present invention relates to a pressure switch having a manually operated safety microswitch, characterized in that it comprises a bottom body, defining in its inside a chamber communicating with a fluid to be controlled, and associated with a top cap, which supports an operating microswitch. The chamber is closed by a membrane, preferably made of a silicone material, provided with an O-ring and coupled to a steel membrane, with a driving tappet assembly which is directly formed on the latter membrane and operates on a washer element, which is counter biased by a first counterbiasing spring and operates on a push-button of the operating microswitch, a safety microswitch being moreover provided, which can be manually operated or re-armed, and cooperating with a pin element extending from the washer.

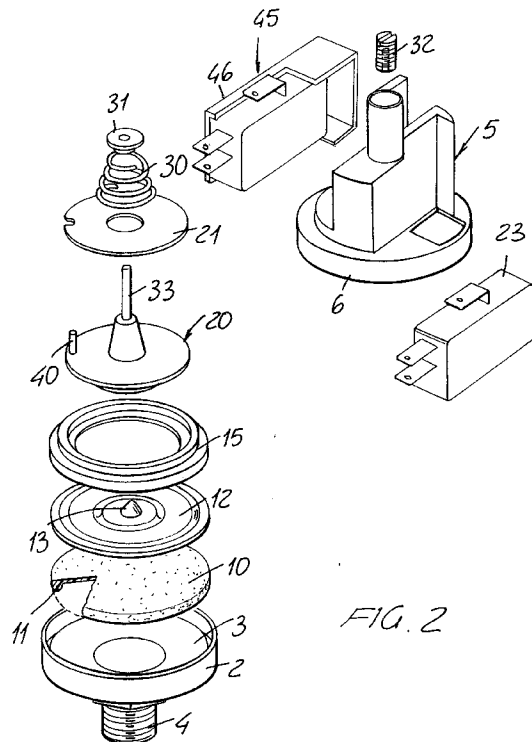

FIG. 2

BACKGROUND OF THE INVENTION

The present invention relates to a pressure switch having a manually operated safety micro-switch.

As is known, for measuring the pressure of fluids in general, there are conventionally used pressure switches, which include a metal membrane associated or circumferentially sealed to an annular edge of a base cap.

Such a construction, however, in addition to requiring very complex machining steps, also includes several zones in which there is at least partially modified the resiliency of the membrane with a consequent random variation of the trip operation characteristics of the assembly.

A further drawback is that the tappet assembly included in these prior pressure switches is usually welded at the central region of the membrane, which contributes to a further changing of the mechanic and resiliency properties of the membrane.

Yet another drawback of the above mentioned prior pressure switches is that, as an overpressure occurs, the pressure switch components can be damaged which requires that recovering operations be performed.

SUMMARY OF THE INVENTION

Accordingly, the aim of the present invention is to overcome the above mentioned drawbacks, by providing a pressure switch, including a manually operated safety microswitch, which provides a perfect tightness with respect to the fluid to be controlled, without requiring any welding operations, so as to greatly improve the resilient responsivity of the membrane.

Within the scope of the above mentioned aim, a main object of the present invention is to provide such a pressure switch, the tapped assembly whereof is made as an integrating portion of the membrane, so as not to modify the physical and operation properties of said membrane.

Yet another object of the present invention is to provide such a pressure switch in which the operation threshold of the membrane can be easily modified in order to quickly and easily fit it to the specific use requirements.

Yet another object of the present invention is to provide such a pressure switch which is very reliable and safe in operation and can be easily made from easily commercially available elements and materials and which, moreover, is very competitive from a mere economic standpoint.

According to one aspect of the present invention, the above mentioned aim and objects, as well as yet other objects, which will become more apparent hereinafter, are achieved by a pressure switch, including

a manually operated safety microswitch, characterized in that said pressure switch comprises a bottom body defining in its inside a chamber communicating with a fluid to be controlled, and being associated with a top cap, supporting an operating microswitch, said chamber being closed by a membrane, preferably made of a silicone material, and including a sealing O-ring and being coupled to a steel membrane, with a related driving tappet assembly, said assembly being directly formed on the latter membrane and driving a washer counterbiased by a first counterbiasing spring, and affecting a push-button of the operating microswitch, a safety manually operated microswitch being moreover provided cooperating with a pin element extending from said washer.

BRIEF DESCRIPTION OF THE DRAWINGS

Further characteristics and advantages of the invention will become more apparent hereinafter from the following detailed disclosure of a preferred embodiment of a pressure switch including a manually operated safety microswitch according to the invention, which is illustrated, by way of an indicative, but not limitative, example, in the figures of the accompanying drawings where:

Figure 1 is an elevation view of the pressure switch according to the present invention;

Figure 2 is an exploded perspective view illustrating the pressure switch according to the invention;

Figure 3 is a vertical cross-sectional view of the subject pressure switch;

and Figure 4 is a detail view illustrating the safety microswitch included in the pressure switch according to the invention.

DESCRIPTION OF THE PREFERRED EMBODIMENT

With reference to the number references of the figures of the accompanying drawings, the pressure switch, including a manually operated safety microswitch, according to the present invention, which has been generally indicated at the reference number 1, comprises a bottom body, or base cap 2 which, in its inside, defines a chamber 3 which, through a duct 4, is communicated with a fluid the pressure of which must be detected or sensed.

To the bottom body 2 there is connected a top cap 5, associated with said bottom body by means of a metal circumferential edging 6.

As shown, the chamber 3 is closed by a membrane 10 which is formed as a single body with a sealing peripheral inner O-ring, adapted to provide a perfect tightness, said membrane being preferably made of a silicone or other suitable material.

Said silicone material membrane 10 is connected to a stainless steel membrane 12 which is superimposed on said membrane 10 and is provided, at the central region thereof, with an integral tappet assembly 13.

As shown, said membranes 10 and 12 are held in a set position by means of a safety ring element 11 which is circumferentially engaged with the membrane 12 and holds in its preset position the sealing O-ring 11 so as to provide both the metallic clamping effect and an accurate tightness provided by said O-ring.

That same safety ring element 15, moreover, prevents the membrane 12 from being deformed as the pressure switch must be adjusted through the dowel element 32.

The tappet assembly 13 affects the central portion of a washer element 20, which is slidably guided on the top cap 5 and supports an aluminium disc 21, having a variable thickness, so as to adjust the operating threshold on the push-button 22 of an operating microswitch 23 which is connected to said cap 5 by means of screws 24.

On the washer 20 and, more precisely, on said aluminium disc 21, abuts a first biasing spring 30, which is coaxially arranged with respect to the washer and houses a top sliding bush 31 which contacts an adjusting screw 32 in turn rotatably supported by the cap 5.

A guide pin 33 is moreover provided, for guiding the washer, which can slide in a hollow 34 formed inside the adjusting screw 32.

From the washer 20 axially projects a pin element 40, which cooperates with a manually operated safety microswitch, generally indicated at the reference number 45, which is supported by the cap 5 by means of a ryton small plate 46, restrained by screws 47.

As shown, the microswitch 45 is provided with an operating lever 48, thereon the pin 40 can operate at different points, which can be set by means of a plurality of engaging slots 50 provided through the cap, in order to allow the lever arm to be easily changed.

If desired, a further thrust spring can moreover be provided.

The lever 48 operates the push-button 52 of the safety microswitch 48 and, at one end portion thereof, interacts with a resilient locking tongue 60, having a lug 61, and which is so arranged as to easily change its latching conditions (see figure 4).

Advantageously, it is furthermore possible to provide a latching spring 62, operating between the locking tongue 60 and the wall of the small plate 46, in order to prevent the resiliency characteristics of the tongue from varying in the time.

Moreover, it is also possible to use a manually resettable microswitch, which does not comprise any small plate, and it is also possible to provide a second biasing spring 70, operating in the chamber 3 on the

membrane, so as to allow the possibility of presetting a plurality of operating threshold values, with a very small working pressure.

In operation, if inside the chamber 3 a pressure value greater than the rated value is generated, then the membrane is upwardly displaced, so as to cause the washer 20 to be also displaced, and energizing the operating microswitch 23.

A possible failure of the microswitch 23 is compensated for by the operation of the safety microswitch, which will be brought to its locking position, with a consequent need of performing a manual resetting operation, by operating the locking lever 60.

The calibrating or rated values can be easily modified by operating, for example, the adjusting screw 32, by introducing several aluminium discs of different thicknesses, in order to reduce the operating travel or by introducing a further biasing spring, operating on the underside of the membrane 10.

Likewise, it is possible to adjust the operation threshold of the safety microswitch by modifying the coupling point between the pin 40, which can also be constituted by a height adjustable screw, and the lever of said safety microswitch.

Even in this case, it is possible to provide a broad adjustment range of the safety microswitch operating threshold, which can be obtained by providing an elongated slot through the mentioned small plate, allowing a clockwise displacement, or, possibly, by using a spring biased screw.

From the above disclosure it should be apparent that the invention fully achieves the intended aim and objects.

In particular the fact is to be pointed out that a pressure switch has been provided adapted to provide very accurate threshold values, since its membrane is not welded but is peripherally held through the interposition of a resilient material membrane, made of a resilient material such as silicone or the like, which is moreover provided with a tightness or sealing O-ring.

Obviously, the subject pressure switch can also be provided with two operating microswitches.

In practicing the invention, the used materials, provided that they are compatible to the intended use, as well as the contingent size and shapes, can be any, according to requirements.

50 Claims

1. A pressure switch, including a manually operated safety microswitch, characterized in that said pressure switch comprises a bottom body defining in its inside a chamber communicating with a fluid to be controlled, and being associated with a top cap, supporting an operating microswitch, said chamber being closed by a membrane, preferably made of a sili-

cone material, and including a sealing O-ring and being coupled to a steel membrane, with a related driving tappet assembly, said assembly being directly formed on the latter membrane and driving a washer counterbiased by a first counterbiasing spring, and affecting a push-button of the operating microswitch, a safety manually operated microswitch being moreover provided cooperating with a pin element extending from said washer.

2. A pressure switch, according to Claim 1, characterized in that that pressure switch comprises a safety ring element interposed between the bottom body and the cap and operating peripherally on the membrane.

3. A pressure switch, according to Claims 1 and 2, characterized in that said pressure switch comprises an adjustment screw, operating on the first reaction spring and being rotatably supported by said cap.

4. A pressure switch, according to one or more of the preceding claims, characterized in that said pressure switch comprises a sliding element interposed between an end portion of the first reaction spring and the adjustment screw.

5. A pressure switch, according to one or more of the preceding claims, characterized in that said safety microswitch is of the safety manually re-armed or re-operated type.

5. A pressure switch, according to one or more of the preceding claims, characterized in that it further comprises, on said safety microswitch, a lever cooperating with the safety push-button of the safety microswitch and engageable by the pin.

7. A pressure switch, according to one or more of the preceding claims, characterized in that on said lever operates a calibrating spring.

8. A pressure switch, according to one or more of the preceding claims, characterized in that said pressure switch further comprises, on said cap, a plurality of differently arranged holes, for allowing said pin to pass therethrough, adapted to provide a different operating point of said pin on the control lever of the safety microswitch.

9. A pressure switch, according to one or more of the preceding claims, characterized in that said pressure switch further comprises, on said washer, an adjustment screw cooperating with said operating microswitch.

10. A pressure switch, according to one or more of the preceding claims, characterized in that said pressure switch further comprises, on said washer, an adjustment and calibrating screw, cooperating with said safety microswitch.

11. A pressure switch, according to one or more of the preceding claims, characterized in that said pressure switch further comprises different thickness aluminium disc elements arranged on said washer, in order to change the trip values of said operating microswitch.

12. A pressure switch, according to one or more of the preceding claims, characterized in that said pressure switch further comprises a second reaction spring arranged under said membrane.

13. A pressure switch, according to one or more of the preceding claims, characterized in that it comprises a locking tongue element for manually re-arming said safety microswitch.

14. A pressure switch, according to one or more of the preceding claims, characterized in that said pressure switch further comprises a latching spring operating on said locking tongue element of said safety microswitch.

15. A pressure switch, according to one or more of the preceding claims, characterized in that said pressure switch further comprises a lug element the shape of which can be adjusted so as to change the latching conditions between said locking tongue elements and said safety microswitch lever.

16. A pressure switch, according to one or more of the preceding claims, characterized in that said safety microswitch is supported by a ryton plate, connected by screws to said cap.

17. A pressure switch, according to one or more of the preceding claims, characterized in that said pressure switch comprises two operating microswitches.

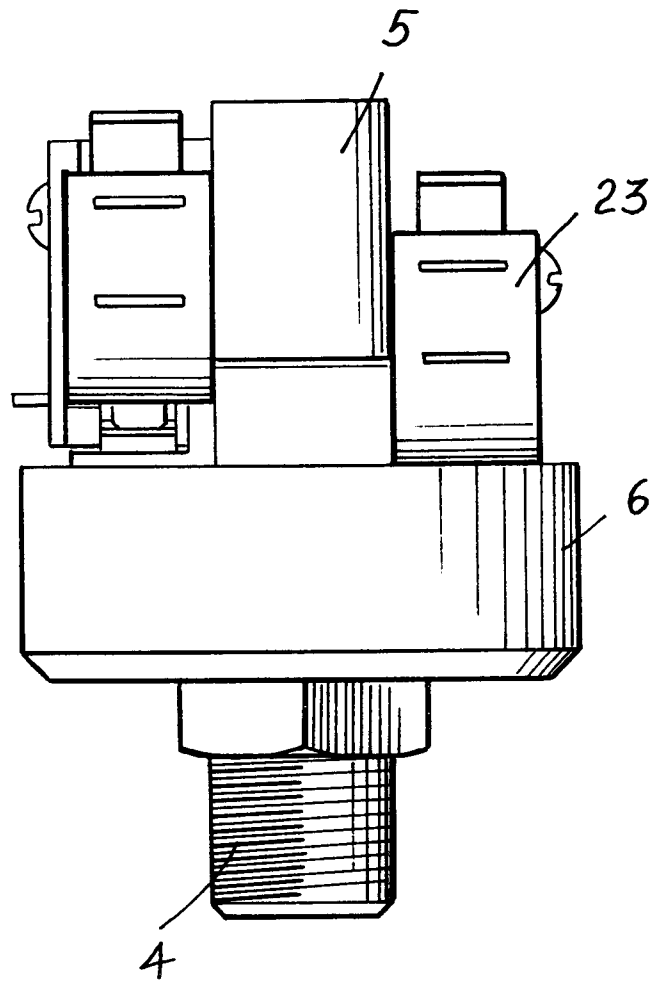

FIG. 1

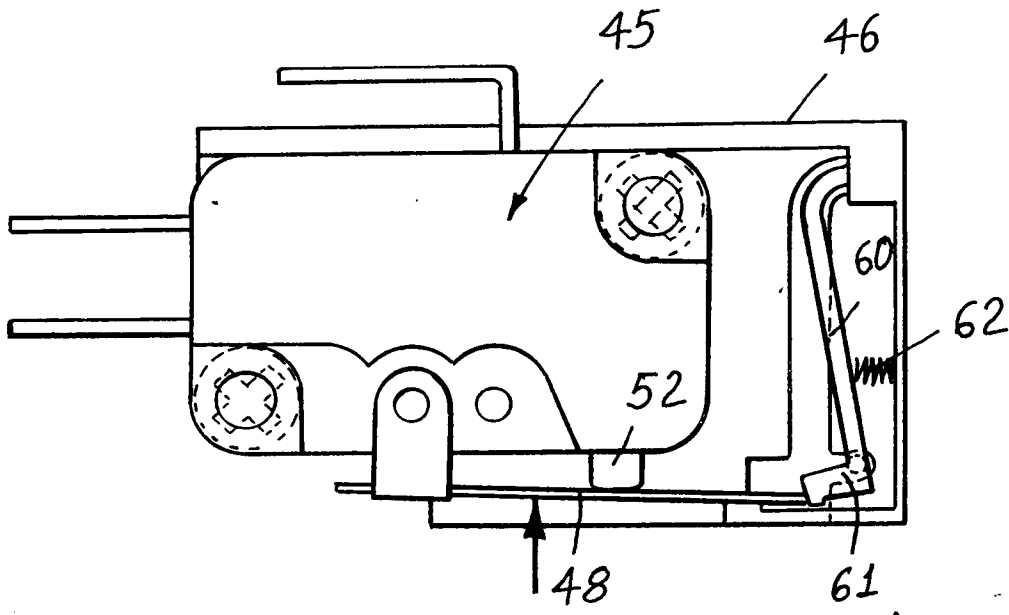

FIG. 4

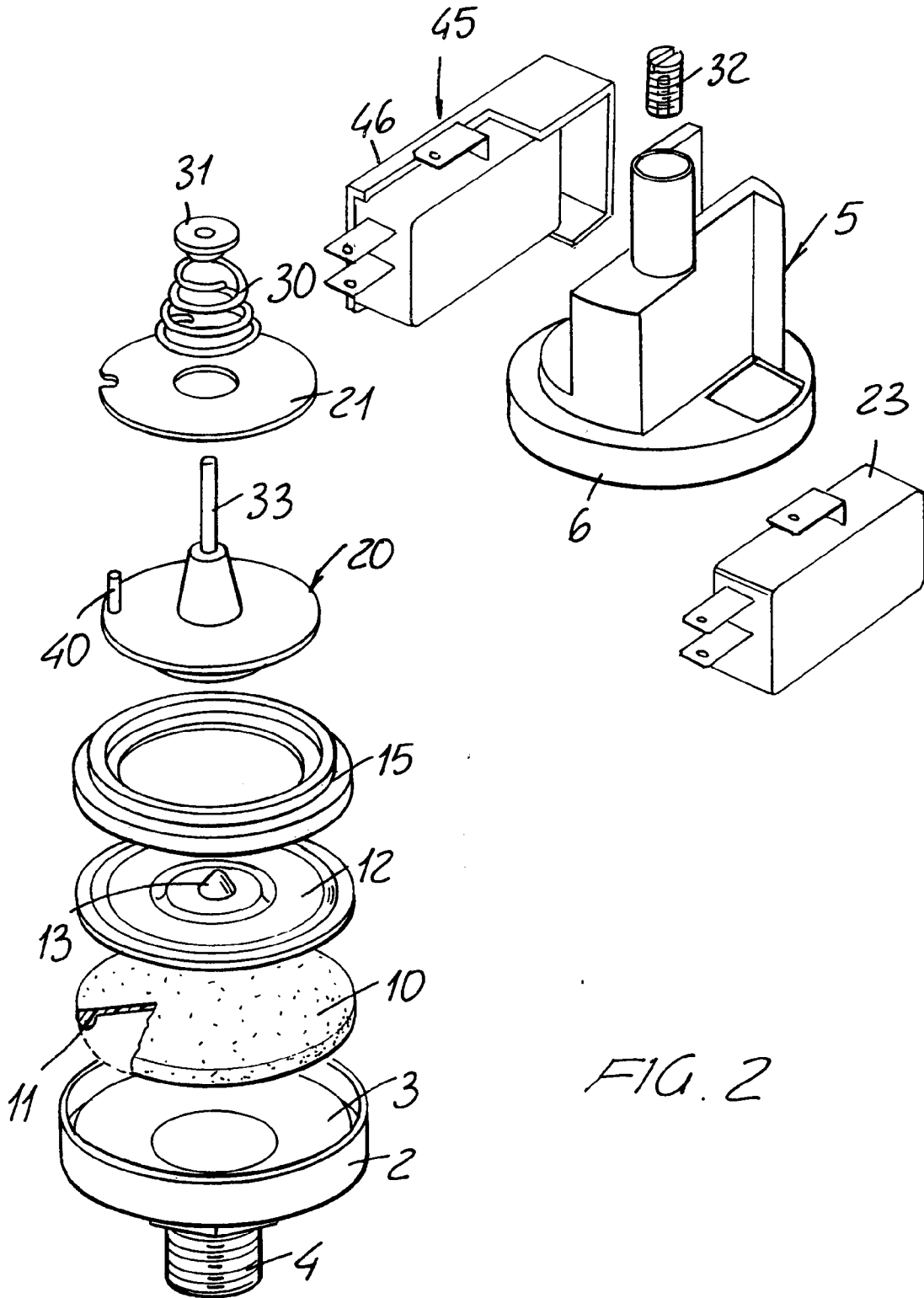

FIG. 2

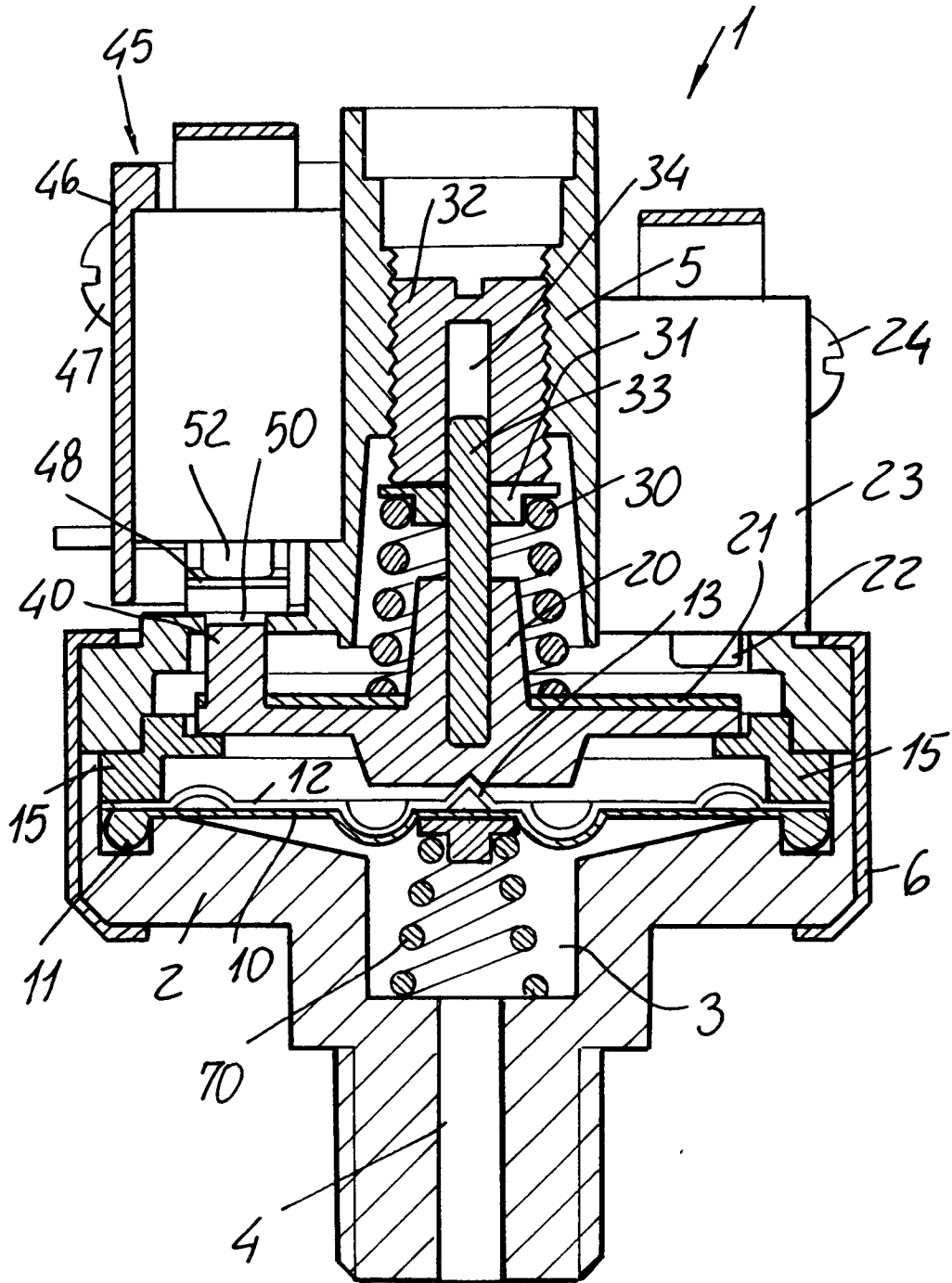

FIG. 3