

(No Model.)

T. L. & T. J. STURTEVANT.  
STEAM GENERATOR SECTION.

No. 524,740.

Patented Aug. 21, 1894.

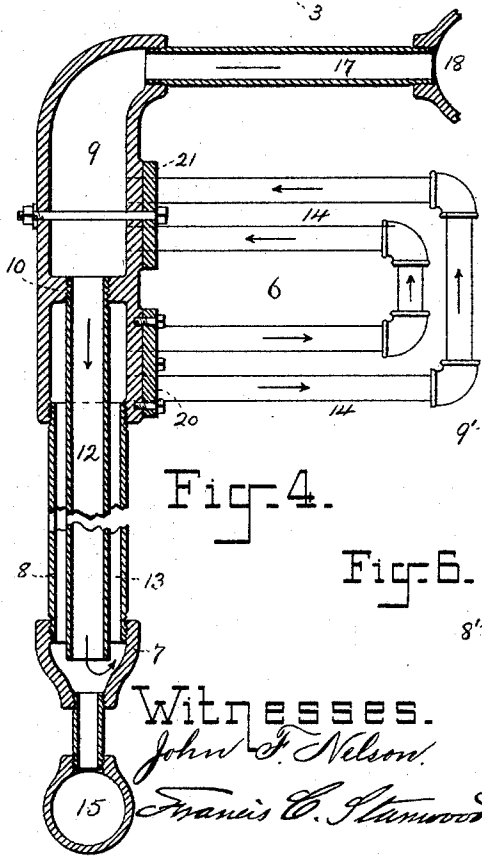
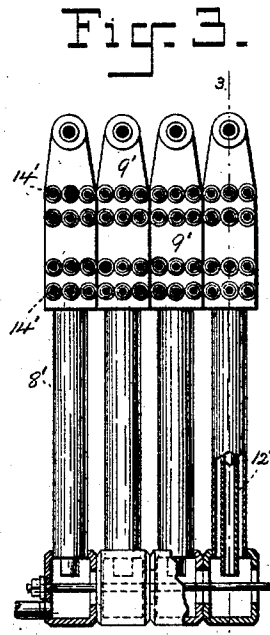
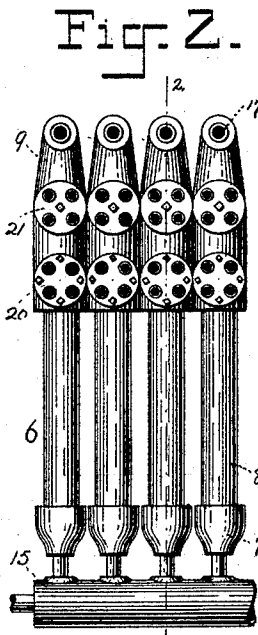
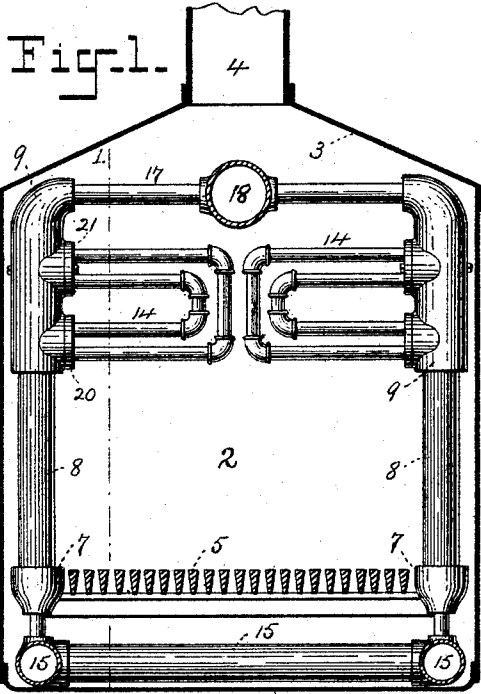

Fig. 4.

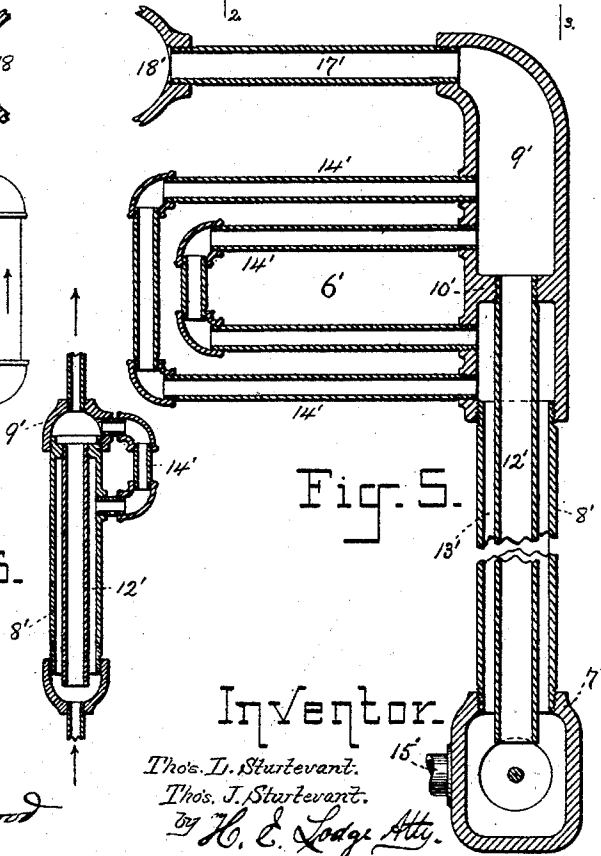

Fig. 5.

Fig. 6.

Witnesses.  
*John F. Nelson.*  
*Francis C. Stanwood*

Inventor.  
*Thos. J. Sturtevant.*  
*Thos. J. Sturtevant.*  
*By H. C. Lodge Atty.*

# UNITED STATES PATENT OFFICE.

THOMAS L. STURTEVANT AND THOMAS J. STURTEVANT, OF QUINCY,  
MASSACHUSETTS.

## STEAM-GENERATOR SECTION.

SPECIFICATION forming part of Letters Patent No. 524,740, dated August 21, 1894.

Application filed October 16, 1893. Serial No. 488,241. (No model.)

To all whom it may concern:

Be it known that we, THOMAS L. STURTEVANT and THOMAS J. STURTEVANT, citizens of the United States, residing at Quincy, in the county of Norfolk and State of Massachusetts, have invented certain new and useful Improvements in Steam-Generator Sections; and we do hereby declare the following to be a full, clear, and exact description of the invention, such as will enable others skilled in the art to which it appertains to make and use the same, reference being had to the accompanying drawings, and to figures of reference marked thereon, which form a part of this specification.

This invention relates to steam generators in which the several sections are composed of pipes and connected in series.

Our present invention consists in improvements upon that shown and described in application Serial No. 446,036, filed by us jointly in September, 1893, and its purpose and object are to make a lighter and cheaper generator having a similar circulation.

The essential features are embodied in the construction of the section, which is made up primarily of two tubes, one secured within the other, the inside tube being open at the lower end, while both ends of the outside tube are closed except for steam discharge and water supply and further adapted for steam and water circulation which is obtained by employing a series of U pipes having one set of extremities inserted in the outside tube, while their opposite ends enter the enlarged upper part of the inside tube. Hence the circulation commences as the water is drawn from the space between the two tubes upwardly and through the U pipes into the closed end of the inside tube, whence it courses down and through said inside tube to the bottom and again commences another circuit through the outside tube.

The drawings accompanying this specification represent in Figure 1 a sectional elevation of a steam generator embodying our invention. Fig. 2 is a section on line 1.1. Fig. 3 shows a modification in the mode of uniting the various sections. Fig. 4 is a vertical section enlarged on line 2. 2. Fig. 5 is a similar view likewise enlarged on line 3. 3. Fig. 6 is

a longitudinal section showing one form of construction.

In said drawings 2 represents the essential parts of a steam generator, as an assemblage contained within a casing 3 and furnished with a stack 4 and grate-bars 5, as ordinarily. The steam generating sections shown at 6, when properly grouped form the side and top walls of the combustion chamber. Each section consists primarily of a base or fitting 7, which constitutes a water-leg and from which rises a tube 8, the latter surmounted by a header 9, termed a separator. Said tube is stopped off by a ring or partition 10 or otherwise at the top, while a second or return tube 12 is contained within the first being somewhat reduced in one portion in order to leave a space 13 between the two tubes. In connection with these two tubes, a series of U pipes 14 is provided and the opposite extremities entered on each side of the stop 10, as shown, one set entering the outside tube below the stop, the other set terminating in the separator 9 which is an enlarged continuation of the inside tube. But since the outside tube is of considerable diameter and to have the steam generating pipes occupy about equal space, said pipes are arranged as shown in Figs. 2 and 3 and more rapid circulation is effected. To secure said pipes to the tubes two circular plates 20, 21 are employed; one being affixed to the separator facing the fire-box, the other to the cap forming a part of the outside tube and facing the fire-box. The upper plate is made fast by means of a bolt, the lower one by a series of fastening screws. Into said plates are entered the ends of the U steam generating pipes which are so arranged as before stated as to occupy nearly the same distance lengthwise of the generator, as the outside tube. In Fig. 3 in lieu of the plates the pipes 14 are entered directly into the header and there are three rows inserted to nearly fill up the space corresponding to that occupied by the outside tube. The U pipes furthermore extend inwardly and form the upper wall of the combustion chamber in connection with similar pipes from the opposite co-operating pipe sections.

In the construction of a generator, the several sections in some instances are connected

in series with a water drum 15, which may extend about three sides of the fire-box. In lieu of this arrangement the water drum may be omitted from the generator and the several fittings 7' united, which together act to form a water drum, the lateral water drums being in this last instanced construction united by a cross pipe 15' as before.

We are aware that steam generators have been constructed in which vertical steam and water tubes are supplied with bent pipes which lead from and are returned to the same tube, but these have comparatively feeble circulation. On the contrary our invention has for its object an increase in the circulation, and in order to carry it into effect in lieu of a single tube two vertical tubes are employed by us. The outer is closed at the top, while the bent steam generating pipes extend from this point and terminate in a chamber which is merely an extension of the inside tube. Our vertical outside tube is a water tube only, the rising liquid therein being forced out at the upper closed end and passed into the steam generating pipes, whence it is delivered into the separator or upper end of the inside tube, and from there gravitates through the inside tube coursing within the latter and emerging into the opposite end of the outside tube, thus the path traveled by the hot water is entirely natural and a very strong and rapid circulation is obtained.

In operating a generator of this class the circulation is as follows: Presuming the proper amount of water has been introduced and heat applied. This heat being first communicated to the water in the space 13 and pipes 14, said water rises by difference in gravity between it and that contained within the inside tube 12, which is cooler. As the water and steam enter the upper portion of the tube 12 they are separated, the water flowing down through the inside tube and emerging into the base 7, whence it again ascends through the space 13. The steam on the other hand rises and escapes into the pipe 17 which leads preferably to a steam drum 18 for use.

By the above method the generator sections are made very compact, while a rapid circulation is effected accompanied by the thorough separation of the steam from the water in each section.

What we claim is—

1. A steam generator section comprising an outer steam generating tube closed at its upper end, an inner return tube extended within said outer tube and open at both ends,

and a series of steam generating tubes which extend laterally within the combustion chamber and connect the upper ends of the said outer and inner tubes, substantially as described.

2. In a steam generator section, the combination with a header having two compartments, of a steam generating pipe entering one of said compartments, a return pipe connecting the other of said compartments with said steam generating tube, and a series of laterally extending steam generating pipes connecting said compartments, substantially as described.

3. In a steam generator section, the combination with a header having a dividing partition forming two compartments, of an outer steam generating pipe opening into one compartment of said header at a point below said partition, an inner return tube depending from said partition and connecting said outer tube with the other compartment of said header, and laterally extending steam generating pipes which enter said header at points above and below said dividing partition and form connections between the two compartments of said header, substantially as described.

4. In a steam generator section, the combination with a header, of an outer steam generating tube entering said header, a partition which divides the latter and closes the end of said steam generating tube, an inner return tube depending from said partition and connecting the other portion of said header with the lower end of said outer steam generating tube, and a series of U-shaped steam generating pipes which extend into the combustion chamber and enter said header at points above and below its dividing partition, substantially as described.

5. In a steam generator section, the combination with an outer steam generating tube and an inner return tube, of a header having two compartments one of which forms a continuation of said outer tube and the other a continuation of said inner tube, and a series of laterally extending steam generating pipes which connect the upper ends of said outer and inner pipes, substantially as described.

In testimony whereof we affix our signatures in presence of two witnesses.

THOS. L. STURTEVANT.  
THOS. J. STURTEVANT.

Witnesses:

W. V. ELLIS,  
H. E. LODGE.