



INTERNATIONAL APPLICATION PUBLISHED UNDER THE PATENT COOPERATION TREATY (PCT)

<p>(51) International Patent Classification³ : A47J 45/08</p>	<p>A1</p>	<p>(11) International Publication Number: WO 82/ 02328 (43) International Publication Date: 22 July 1982 (22.07.82)</p>
<p>(21) International Application Number: PCT/US81/00027 (22) International Filing Date: 8 January 1981 (08.01.81) (71)(72) Applicant and Inventor: REYNOLDS, Douglas D. [US/US]; 426 Brook Glen, Richardson, TX 75080 (US). (74) Agents: McFALL, Robert, A. et al.; 100 Northeast Adams Street, Peoria, IL 61629 (US). (81) Designated State: US.</p> <p>Published <i>With international search report. Upon request of the applicant under article 64(3)(c)(i).</i></p>		
<p>(54) Title: CHISEL VIBRATION ISOLATOR</p>		

(57) Abstract

A vibration isolator (10) for controllably guiding an impact-driven tool chisel (12). Long-term exposure to the severe vibration levels experienced by operators of high frequency impact tools may result in physical damage to the operator's chisel supporting hand. This problem is solved by providing a chisel vibration isolator (10) that slidably extends about a tool chisel (12) during normal operation and is selectively clampable to the chisel (12) only when necessary for the movement or repositioning of a tool head or the chisel (12) received therein. The present invention is particularly useful in conjunction with chipping hammers employed in the metal casting industry for removing flash from rough castings.

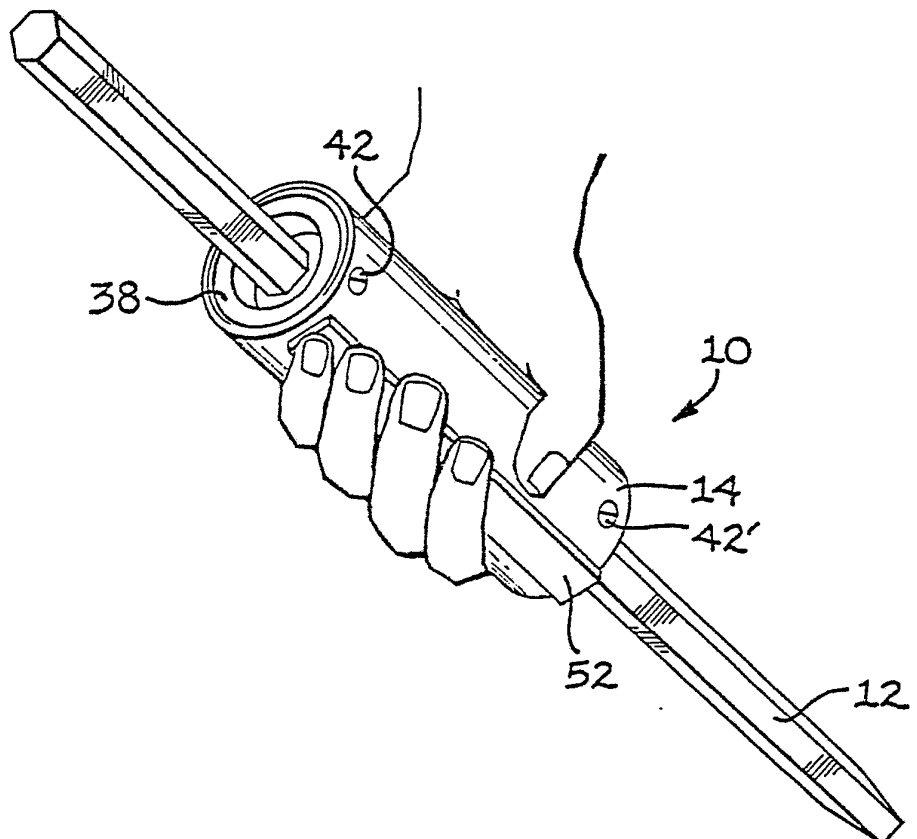

FOR THE PURPOSES OF INFORMATION ONLY

Codes used to identify States party to the PCT on the front pages of pamphlets publishing international applications under the PCT.

AT	Austria	KP	Democratic People's Republic of Korea
AU	Australia	LI	Liechtenstein
BE	Belgium	LK	Sri Lanka
BR	Brazil	LU	Luxembourg
CF	Central African Republic	MC	Monaco
CG	Congo	MG	Madagascar
CH	Switzerland	MW	Malawi
CM	Cameroon	NL	Netherlands
DE	Germany, Federal Republic of	NO	Norway
DK	Denmark	RO	Romania
FI	Finland	SE	Sweden
FR	France	SN	Senegal
GA	Gabon	SU	Soviet Union
GB	United Kingdom	TD	Chad
HU	Hungary	TG	Togo
JP	Japan	US	United States of America

-1-

DescriptionChisel Vibration IsolatorTechnical Field

5 This invention relates generally to a vibration isolating hand grip for use with hand held pneumatic tools and more particularly to a chisel vibration isolator for controllably guiding an impact-driven tool chisel.

10

Background Art

 In the metal casting industry, for example, pneumatic chipping hammers are widely used to remove flash from rough castings. Such chipping hammers
15 require the operator to position and controllably direct the chisel during operation by gripping or otherwise supporting a shank portion of the chisel. It has been noted in various medical journals that continuous, long-term exposure to high amplitude
20 vibrations, such as the vibration encountered by the chisel-supporting hand of a chipping hammer operator, may impair blood circulation in the hand and cause possible damage to capillary vessels. This condition is commonly referred to as "vibration-induced white
25 finger (VWF)", "occupational Raynaud's disease", or "vibration syndrome". A review of the physical problems that may accrue from extended operation of vibrating tools was presented by Kenneth M. Smith in "Undesirable Effects of Vibrating Tools Upon Industrial
30 Workers", Transactions Bulletin No. 14
Chemical-Engineering Conference, Fourteenth Annual Meeting - November 16, 1949, pp 22-28, sponsored by the Industrial Hygiene Foundation of America, Inc.

 In addition to the adverse effects
35 attributable to vibration, such tools become hot during



-2-

use and present an additional hazard to the operator. One approach to overcoming this problem has been the use of heavy heat-insulating gloves. However, the bulk of such gloves decreases the holdability and controllability of the tool.

5 Vibration isolating grips that are clamped directly onto the chisel shank prior to operation have been previously developed. One such isolator is disclosed in the aforementioned article by Kenneth M. Smith and consists of an air operated chisel gripping
10 element supported within a shell by a pair of rubber ring-type isolators. The grip is clamped onto the chisel shank at a fixed, predetermined position by inflating an internal bladder to force the bladder into contact with the chisel shank. An improvement on this
15 earlier isolation grip is disclosed in U.S. Patent Re. 29,402 issued to Daniel Bronson Shotwell on September 20, 1977. The Shotwell isolation grip provides a manually actuatable pump for the inflation of an internally disposed bladder for fixedly clamping
20 the grip at a predetermined position on the chisel shank.

In both of the prior art constructions, the tool shank-contacting bladder elements were spaced from an outer manually grippable rigid sleeve by a pair of
25 rubber rings or end walls. In both of these constructions, attenuation of vibration from the chisel shank to the operator's hand was dependent upon the vibration energy attenuation characteristics of the bladder and rubber spacer rings which were further
30 limited by factors such as optimum size, weight and durability.

While these grips did significantly reduce the amount of vibration transmitted to the operator's hand, the fixed position of the grip on the chisel shank
35 proved to be an impediment to efficient use of the



-3-

tool, particularly in removing internal flash or working in tight or confined spaces. In actual practice, whenever it became desirable to change the position of the grip on the chisel shank, it was necessary to stop the tool, unclamp the grip, 5 reposition it at the desired position, reclamp the grip, and resume operation of the tool. If the new position was not quite satisfactory, the above procedure was repeated until the grip was located at the required operating position.

10 It is therefore desirable to provide a chisel vibration isolator that is readily repositionable on the tool shank and is not dependent upon the material and design limitations of the prior art structures for vibration attenuation. The present invention is 15 directed at overcoming one or more of the problems as set forth above.

Disclosure of the Invention

20 In accordance with one aspect of the present invention a chisel vibration isolator for controllably guiding an impact-driven tool is constructed to slidably extend about a tool chisel during operation and includes a means for selectively clamping the isolator in fixed relationship relative to the chisel.

25 Current chisel-vibration isolating grips are fixedly clamped at a predetermined position on a chisel shank prior to operation of the tool by a worker. As a result, the present isolators are not easily adaptable to work situations requiring frequent repositioning of 30 the isolator on the chisel shank. Further, when the isolator is clamped to the tool shank during operation, the amount of attenuation provided is restricted by design limitations and in particular by the physical characteristics of the material used in the 35 construction of the isolator.



-4-

The present invention solves the above problem by clamping the isolator to the chisel shank only during those periods of time when it is necessary to move or reposition the chisel, such as when moving the tool assembly from one workpiece to the next, or for momentarily providing retention of the chisel within the tool head. In normal operation, the present invention slidably extends about the chisel shank leaving the shank free to reciprocate within the isolator. In this manner, the primary vibration forces, i.e., those which are parallel to the longitudinal axis of the chisel shank, are not communicated to the isolator and hence the requirement for large scale vibration absorption is avoided. Furthermore, the present invention provides a construction for impeding the transmission of secondary or lower amplitude vibrations directed normal to the longitudinal axis of the chisel.

Brief Description of the Drawings

Fig. 1 is an isometric view of a tool chisel slidably mounted within the chisel vibration isolator of the present invention.

Fig. 2 is a side sectional view of a preferred embodiment of the present invention shown in Fig. 1.

Fig. 3 is a cross-sectional view of the preferred embodiment of the present invention taken along the lines III-III in Fig. 2.

Fig. 4 is a side sectional view of a second embodiment of the present invention shown in Fig. 1.

Fig. 5 is a cross-sectional view of the second embodiment of the present invention taken along the lines V-V in Fig. 4.



Best Mode for Carrying Out the Invention

In Fig. 1, a chisel vibration isolator 10 for controllably guiding an impact-driven tool chisel according to the present invention is shown in conjunction with a hexagonally-sectioned tool chisel 12. The chisel vibration isolator 10 includes a rigid, preferably metal, tubular outer case 14, having an outer cylindrical surface 16, an inner surface 18, and an elastomeric liner 20, preferably constructed of 30 durometer neoprene rubber, centrally disposed within the outer case 14. As best seen in Figs. 2 and 3, the liner 20 has an outer surface 22 generally conforming to the inner surface 18 of the case 14, and an inner surface 24 concentrically formed with respect to the outer surface 22.

The chisel vibration isolator 10 also includes a first means 26 for slidably extending about the chisel 12 during normal operation of the chisel. The first means 26 includes a cylindrically shaped outer surface 28 disposed adjacent and generally conforming with the inner surface 24 of the elastomeric liner 20 and a hexagonally-shaped chisel-guiding surface 30 generally conforming to the cross-sectional shape of the tool chisel 12. To provide for the desired free longitudinal movement of the chisel 12 within the first mean 26 during normal operation, the chisel-guiding surface 30 has a diametrical dimension slightly larger than that of the chisel section. To further provide for the free reciprocation of the chisel 12 within the first means 26, it is highly desirable to construct the first means 26 of a material having a dynamic coefficient of friction with steel of less than 0.15. In general, plastic materials selected from the group consisting of acetal resin, fluoroplastic, polyamide, and migratory internally lubricated thermoplastic have

-6-

the desired low-friction characteristics. In particular, it has been found that polytetrafluoroethylene (PTFE, commonly referred to as TFE) has a dynamic coefficient of friction against steel of 0.050 when measured with an applied loading of 700 KPa (100 psi) at a relative movement of .05 m/s (10 fpm). In addition to exhibiting desirable frictional properties, TFE has excellent mechanical and thermal properties. As is known in the art, TFE is commercially available under the trade names of Teflon TFE (DuPont), Holon TFE (Allied Chemical) or Fluon (ICI America). Also acceptable are copolymer acetal resins, which are harder than TFE, have a coefficient of friction with steel of 0.15, and have somewhat lower thermal properties. Polyamides, known more commonly as nylons, generally have excellent physical properties and low coefficients of friction. In particular, molybdenum disulfide filled nylon is widely used as a self-lubricating bearing material in industrial equipment. More recently, a new class of internally lubricated materials, called migratory internally lubricated thermoplastics have been developed. These compounds are blends of resins such as nylon or acetal and silicone, are self lubricating, and have excellent wear and low friction characteristics.

The elastomeric liner 20 and the first means 26 are axially positioned and secured within the outer case 14 with the liner 20 interposed the case 14 and first means 26 by a pair of retaining rings 32,32'. Each of the retaining rings 32,32' includes an annular metallic ring 34,34' having a plurality of radially disposed threaded bores 36,36' and is bonded or molded in place between a pair of 30 durometer neoprene rubber caps 38,38' and 40,40'. The retaining rings 32,32' have a radially outer dimension substantially equal to inner surface 18 of the case 14 and are retained in

-7-

position, adjacent each of the axial ends of the tubular case 14, by a plurality of screws 42,42' extending through the case 14 and threadably engaging the threaded bores 36,36' formed in the rings 34,34'. The elastomeric liner 20 and the first means 26 also
5 respectively have a rectangular opening 44,46 extending radially through the liner 20 and the first means 26.

The chisel vibration isolator 10 also includes a second means 48 for selectively controllably clamping the isolator 10 in fixed position relative to the tool
10 chisel 12. The second means 48 includes a friction member 50 movably disposed within the rectangular openings 44,46 for movement between a first position at which the friction member 50 is spaced from tool chisel
15 12, as shown in the drawings, and a second position at which the friction member 50 is in contact with the chisel 12. The friction member 50 is preferably constructed of bronze, brass, or other material having a high coefficient of friction with steel. A manually actuatable control bar 52 is attached in fixed, spaced
20 relationship to the friction member 50 by a pair of machine screws 54,54' extending respectively through a pair of tubular spacers 56,56' interposed the control bar 52 and the friction member 50. The second means 48 also includes a third means 58 for maintaining the
25 friction member 50 in the above-described first position. In the present embodiment, the third means 58 includes a pair of coil springs 60,60' placed around the spacers 56,56' to apply a biasing force between the case 14 and the control bar 52 to urge the control bar
30 52 radially outwardly and thereby space the attached friction member 50 away from the tool chisel 12.

In the alternate embodiment of the present invention shown in Figs. 4 and 5, the chisel vibration isolator 10 also includes a reaction member 62 having a
35 friction surface 64 disposed adjacent the



-8-

chisel-guiding surface 30 of the first means 26. The reaction member 62 is preferably constructed of bronze, brass, or other friction material, and is disposed within a rectangular recess 66 provided in the liner 20 and the first means 26 at a position radially spaced from the friction member 50. The reaction member 62 is retained within the recess 66 by a pair of screws 68,68' extending through the outer case 14.

Industrial Applicability

To place the chisel vibration isolator 10 of the present invention in use, a tool chisel 12 of the desired configuration is inserted axially through the isolator 10, so that a shank portion of the tool chisel 12 is slidably supported within the isolator 10. As shown in Fig. 1, the isolator 10 is then oriented in the operator's hand so that the operator's fingers comfortably rest on the control bar 52. Next, the control bar is depressed by the operator to clamp the vibration isolator 10 to the tool chisel 12 for movement as a single unit, and the shank end of the chisel 12 is inserted into a tool receiving socket of a tool head. For a right-handed person, the tool head, containing an operating switch therein, is generally supported in the right hand and the chisel vibration isolator is supported in the left hand.

During normal chipping operations, finger pressure on the control bar 52 is relaxed and the third means 58 acts to space the friction member 50 away from the chisel 12. In this operating mode, the chisel 12 is free to move in an axial direction independently of the isolator 12, and is controllably guided laterally by the chisel-guiding surface 30 of the first means 26. When the operator desires to move the tool head to a new position, finger pressure is selectively reapplied to the control bar 52, thereby clamping the



-9-

isolator 10 and the chisel 12 together for movement as a single unit. The reaction member 50, disclosed in the alternate embodiment, provides an added friction surface 64 which is generally not required for most smaller tool chisels, but may be desirable for
5 additional clamping action when the isolator 10 is used with large or heavy tools.

In many chipping operations such as in the removal of flash or fins from rough castings, it is desirable to use chipping hammers having a
10 retention-free tool receiving socket, i.e., the tool chisel 12 is not physically restrained within the tool head. This feature presents no problem when the chisel 12 is working against a reactive force. However, when the flash breaks away, the chisel 12 may momentarily be
15 unimpeded by any reactive force and, in the absence of physical restraint, become axially extended from the tool head. In the operation of the present invention, the operator can prevent the undesired separation of the chisel 12 from the tool head by momentarily
20 applying a light or moderate finger pressure to the control bar 52. This action brings the friction member 50 into limited contact with the tool chisel 12 and thereby provides the required reactive force to prevent escape of the chisel from the tool head.

25 As can be readily appreciated from the above structural and operational descriptions, transmission of the primary vibration forces -- the forces acting along a line parallel with the longitudinal axis of the chisel 12 -- is avoided during normal operation by
30 allowing the chisel to freely move in the axial direction within the isolator 10. In a controlled test of an isolator constructed according to the present invention, the average acceleration measured on the outer case 14 was less than 0.1 m/sec^2 over a
35 frequency range of 5 to 1000 Hz. Separate



-10-

measurements, made on the chisel 12, without the isolator in place, yielded average accelerations in the range of 1,000 to 10,000 m/sec² over the same frequency range. In addition, it has been determined that an isolator constructed according to the present invention does not exhibit undesirable heat build-up characteristics. During all testing, the isolator remained at a temperature acceptable to the operator. Additional hand protection to protect the operator from heat generated by or transmitted through the isolator was not required.

To attenuate the much lower amplitude vibrations acting normal to the longitudinal axis of the tool chisel 12, it is desirable to use materials for the first means 26, the elastomeric liner 20, and the case 14 that have widely diverse mechanical properties. Preferably, the characteristic impedances of adjacent materials should be vastly different to provide a high degree of impedance mismatching between adjacent materials and thereby reduce the transmission of vibration therebetween. For example, in the present invention, the elastomeric liner 20 is preferably constructed of a rubber material that is significantly softer and has a substantially lower characteristic impedance than either the metal case 14 or the polytetrafluoroethylene first means 26.

Other aspects, objects and advantages of this invention can be obtained from a study of the drawings, the disclosure and the appended claims.



-11-
Claims

Chisel Vibration Isolator

1. In a chisel vibration isolator (10) for
5 controllably guiding an impact-driven tool chisel (12),
said isolator (10) having an outer case (14), and an
elastomeric liner (20) disposed within said outer case
(14), the improvement comprising:

first means (26) for slidably extending about
10 said tool chisel (12) during operation of the chisel
(12), said first means (26) being disposed within said
liner (20); and,

second means (48) for selectively controllably
clamping said chisel vibration isolator (10) in fixed
15 relationship relative to said chisel (12).

2. The chisel vibration isolator (10) as set
forth in claim 1, wherein said first means (26) is
constructed of a material having a dynamic coefficient
20 of friction with steel of less than 0.15.

3. The chisel vibration isolator (10), as set
forth in claim 2, wherein said first means (26) is
constructed of a plastic material selected from the
25 group consisting of acetal resin, fluoroplastic,
polyamide, and migratory internally lubricated
thermoplastic.

4. The chisel vibration isolator (10), as set
30 forth in claim 3, wherein said first means (26) is
constructed of polytetrafluoroethylene.



-12-

5. The chisel vibration isolator (10), as set forth in claim 1, wherein said second means (48) includes a friction member (50) being movable between a first position at which said friction member (50) is spaced from said tool chisel (12) and a second position at which said friction member (50) is in contact with said chisel (12), an actuatable control bar (52) attached to said friction member (50), and third means (58) for maintaining said friction member (50) in said first position relative to said chisel (12).

10

6. The chisel vibration isolator (10), as set forth in claim 5, the improvement further comprising: a reaction member (62) having a friction surface (64), said surface being disposed adjacent a chisel-guiding surface (30) of said first means (26) at a position radially spaced from said friction member (50).

7. A chisel vibration isolator (10), comprising:
a case (14);
first means (26) for slidably circumscribing a tool chisel (12) during operation of said chisel (12), said first means (26) being disposed within said tubular case (14);
an elastomeric liner (20) interposed said case (14) and said first means (26); and,
second means (48) for selectively controllably clamping said chisel vibration isolator (10) in fixed relationship relative to said chisel (12).

8. The chisel vibration isolator (10), as set forth in claim 7 wherein said first means (26) is constructed of a material having a dynamic coefficient of friction with steel of less than 0.25.



-13-

9. The chisel vibration isolator (10) as set forth in claim 8 wherein said first means (26) is constructed of a plastic material selected from the group consisting of; acetal resin, fluoroplastic, polyamide, and migratory internally lubricated thermoplastic.

10. The chisel vibration isolator (10) as set forth in claim 9 wherein said first means (26) is constructed of polytetrafluoroethylene.

11. The chisel vibration isolator (10) as set forth in claim 7, wherein said second means (48) includes a friction member (50) being movable between a first position at which said friction member (50) is spaced from said tool chisel (12) and a second position at which said friction member (50) is in contact with said chisel (12), an actuatable control bar (52) attached to said friction member (50), and third means (58) for maintaining said friction member (50) in said first position relative to said chisel (12).

12. The chisel vibration isolator (10) as set forth in claim 11, including:
a reaction member (62) having a friction surface (64), said surface being disposed adjacent a chisel-guiding surface (30) of said first means (26) at a position radially spaced from said friction member (50).



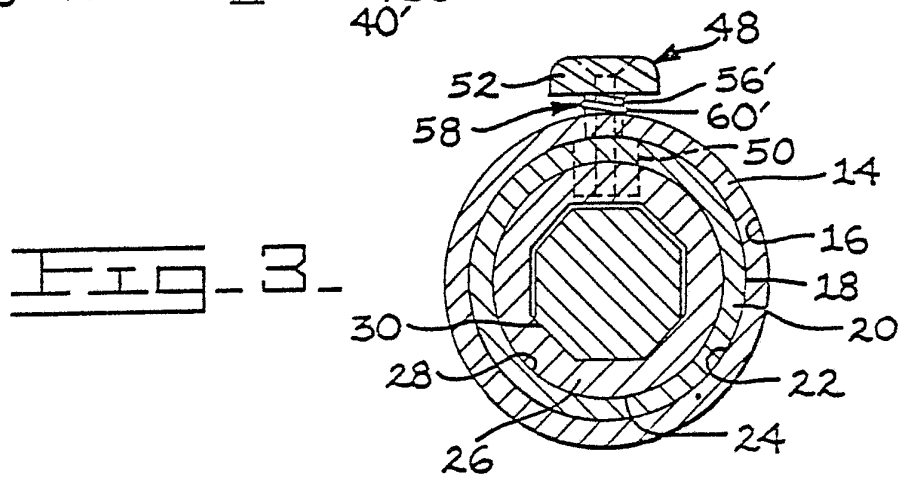
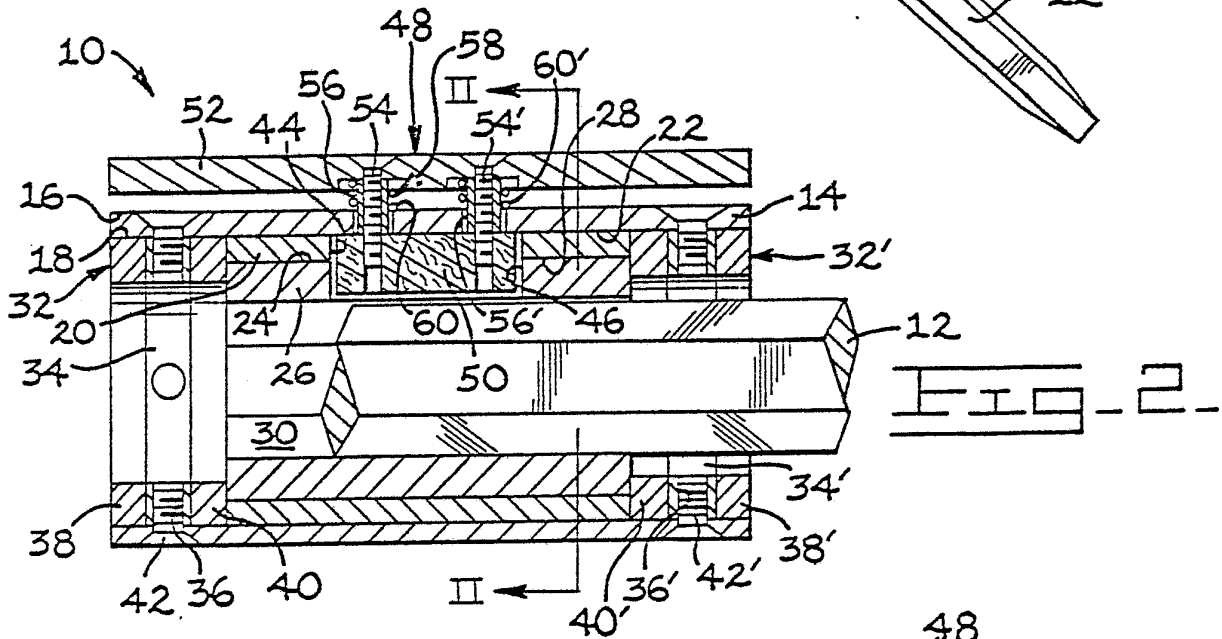
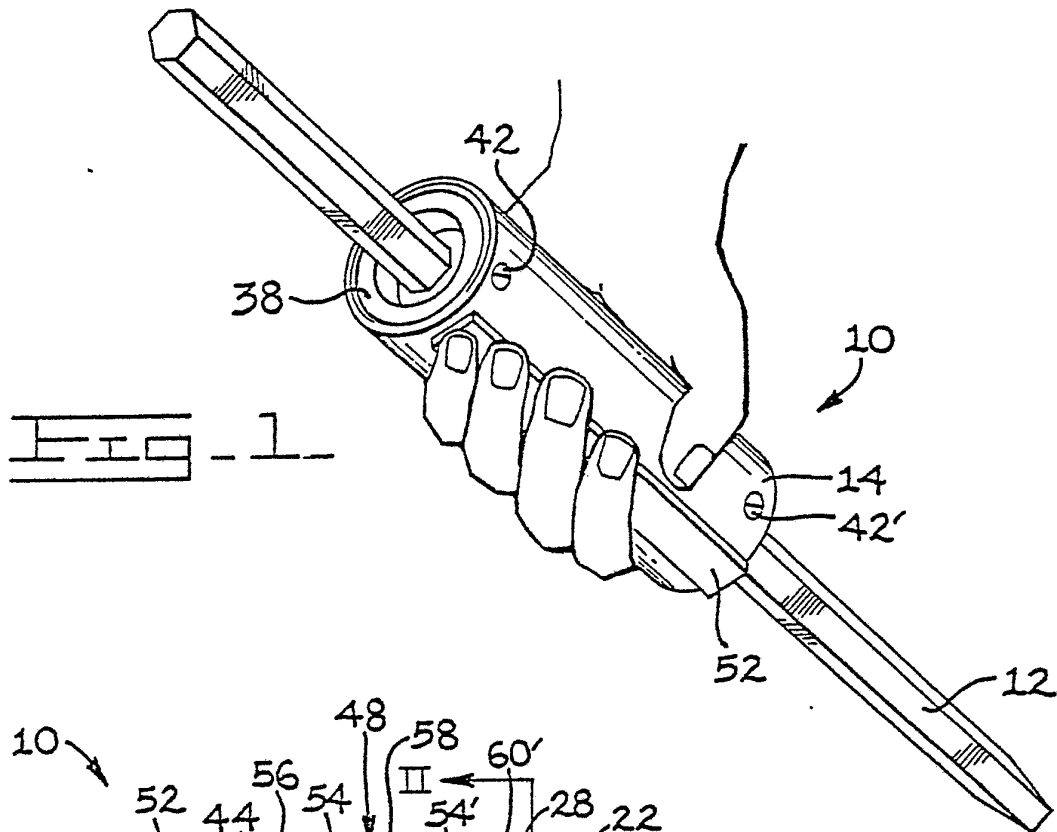

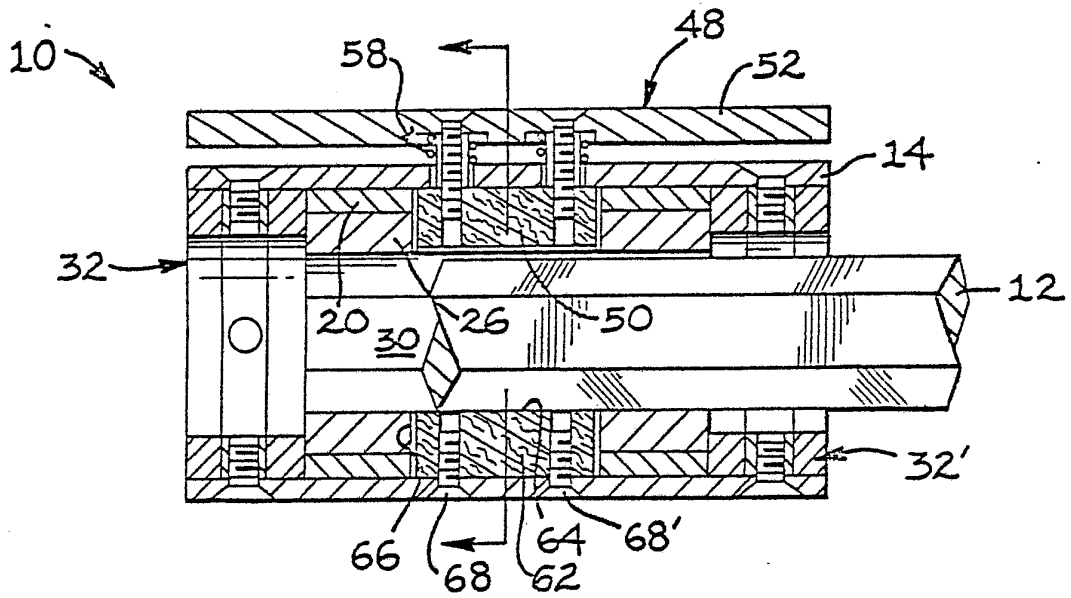

FIG - 4 -

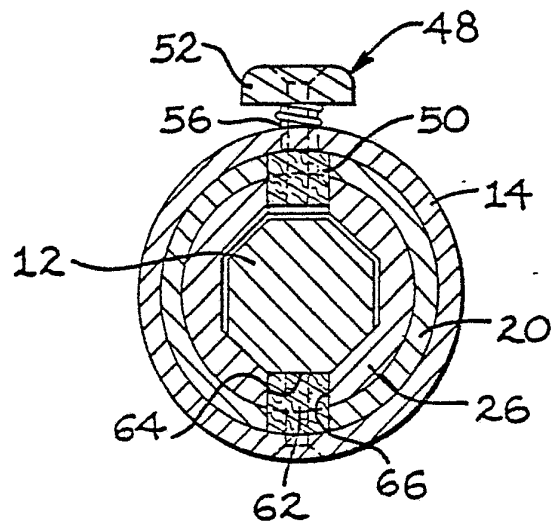

FIG - 5 -

INTERNATIONAL SEARCH REPORT

International Application No

PCT/US 81 / 00027

I. CLASSIFICATION OF SUBJECT MATTER (if several classification symbols apply, indicate all) ³				
According to International Patent Classification (IPC) or to both National Classification and IPC INT. CL. A47J 45/08 U.S. CL. 16/116R				
II. FIELDS SEARCHED				
Minimum Documentation Searched ⁴				
Classification System	Classification Symbols			
U.S.	16/116R, 110R 173/162, 139, 162H 267/137 74/558.5 188/67,381 7/167 2/20			
Documentation Searched other than Minimum Documentation to the Extent that such Documents are Included in the Fields Searched ⁵				
III. DOCUMENTS CONSIDERED TO BE RELEVANT ¹⁴				
Category ⁶	Citation of Document, ¹⁶ with indication, where appropriate, of the relevant passages ¹⁷	Relevant to Claim No. ¹⁸		
A	US, E, Re. 29,402 Published 20 September 1977 Shotwell	5,6,11,12		
X	US, A, 4,044,625 Published 30 August 1977 D'Haem	1-4, 7-10		
A	SU, A, 199,025 Published 28 June 1967	1-12		
<p>¹⁵ Special categories of cited documents:</p> <table style="width: 100%; border: none;"> <tr> <td style="width: 50%; border: none;"> <p>"A" document defining the general state of the art</p> <p>"E" earlier document but published on or after the international filing date</p> <p>"L" document cited for special reason other than those referred to in the other categories</p> <p>"O" document referring to an oral disclosure, use, exhibition or other means</p> </td> <td style="width: 50%; border: none;"> <p>"P" document published prior to the international filing date but on or after the priority date claimed</p> <p>"T" later document published on or after the international filing date or priority date and not in conflict with the application, but cited to understand the principle or theory underlying the invention</p> <p>"X" document of particular relevance</p> </td> </tr> </table>			<p>"A" document defining the general state of the art</p> <p>"E" earlier document but published on or after the international filing date</p> <p>"L" document cited for special reason other than those referred to in the other categories</p> <p>"O" document referring to an oral disclosure, use, exhibition or other means</p>	<p>"P" document published prior to the international filing date but on or after the priority date claimed</p> <p>"T" later document published on or after the international filing date or priority date and not in conflict with the application, but cited to understand the principle or theory underlying the invention</p> <p>"X" document of particular relevance</p>
<p>"A" document defining the general state of the art</p> <p>"E" earlier document but published on or after the international filing date</p> <p>"L" document cited for special reason other than those referred to in the other categories</p> <p>"O" document referring to an oral disclosure, use, exhibition or other means</p>	<p>"P" document published prior to the international filing date but on or after the priority date claimed</p> <p>"T" later document published on or after the international filing date or priority date and not in conflict with the application, but cited to understand the principle or theory underlying the invention</p> <p>"X" document of particular relevance</p>			
IV. CERTIFICATION				
Date of the Actual Completion of the International Search ¹	Date of Mailing of this International Search Report ²			
02 September 1981	11 SEP 1981			
International Searching Authority ¹	Signature of Authorized Officer ²⁰			
ISA/US	