

- [54] **FLOATABLE, TELESCOPING, TRANSPORTABLE SHELTER**
- [75] Inventors: **Raymond S. Daughenbaugh, Ojai; Lewis B. Simon, Oxnard; Frank R. Braun, Camarillo, all of Calif.**
- [73] Assignee: **The United States of America as represented by the Secretary of the Navy, Washington, D.C.**
- [22] Filed: **Nov. 1, 1973**
- [21] Appl. No.: **411,931**
- [52] U.S. Cl. **9/1 R, 296/23 C**
- [51] Int. Cl. **B63c 13/00, B60p 3/34**
- [58] Field of Search **9/1 R, 1 T; 52/67; 296/23 C, 26, 27; 280/30; 115/1 R**

3,212,810 10/1965 Bass 296/23 C
 3,628,203 12/1971 Nohse 9/1 T

Primary Examiner—Trygve M. Blix
Assistant Examiner—Charles E. Frankfort
Attorney, Agent, or Firm—Richard S. Sciascia; Joseph M. St. Amand; Darrell E. Hollis

- [56] **References Cited**
UNITED STATES PATENTS
- | | | | |
|-----------|--------|---------------|----------|
| 1,456,478 | 5/1923 | White | 52/67 |
| 2,606,057 | 8/1952 | Johnson | 296/23 C |

[57] **ABSTRACT**

A floatable, telescoping, transportable shelter comprises an end section containing a plurality of telescoping middle sections which are pulled therefrom to form the shelter. A bulkhead provides a cover for the end section and a closure member for the last telescoped middle section. Seals for rendering the shelter water-tight are also provided. Wheels are attached to a side of the end section so that the shelter must be tipped over on its bottom in order to slide out the telescoping middle section, thereby providing easily removable wheels and imparting maximum stability to the shelter.

5 Claims, 3 Drawing Figures

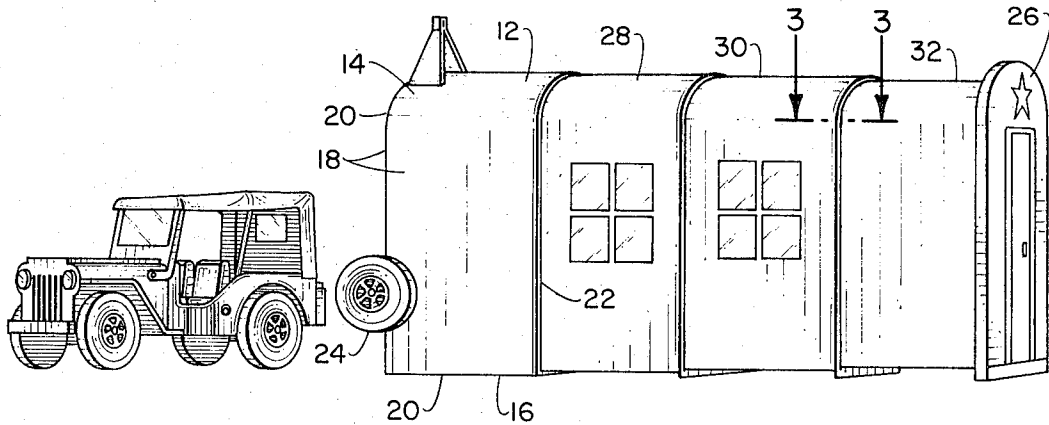

Fig. 1.

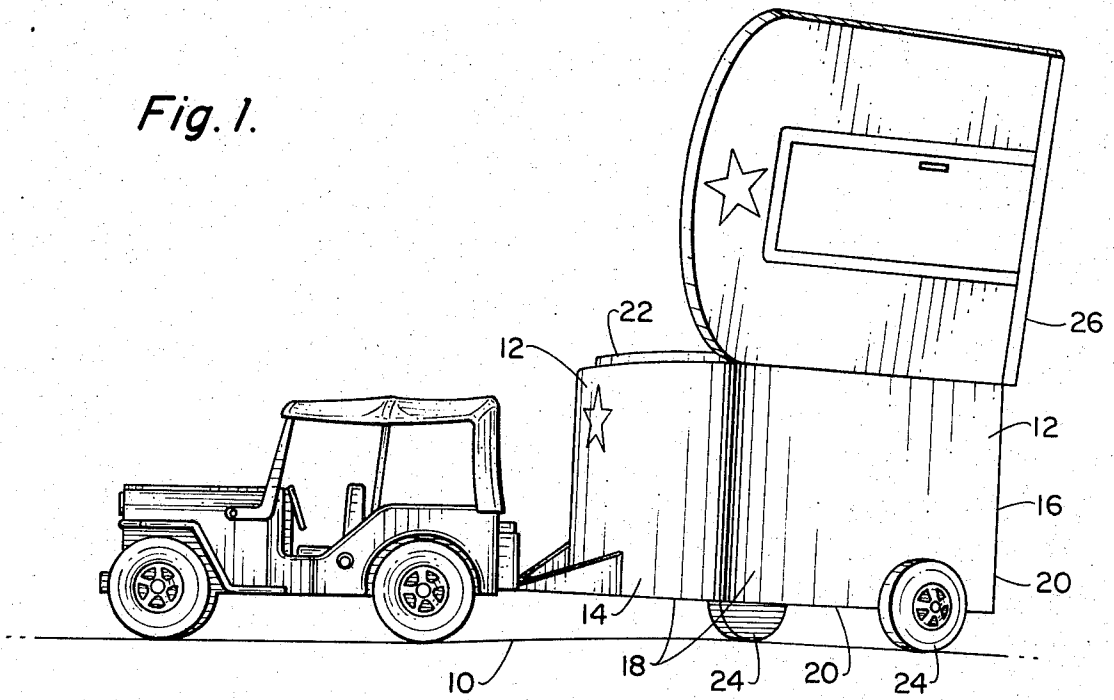

Fig. 2.

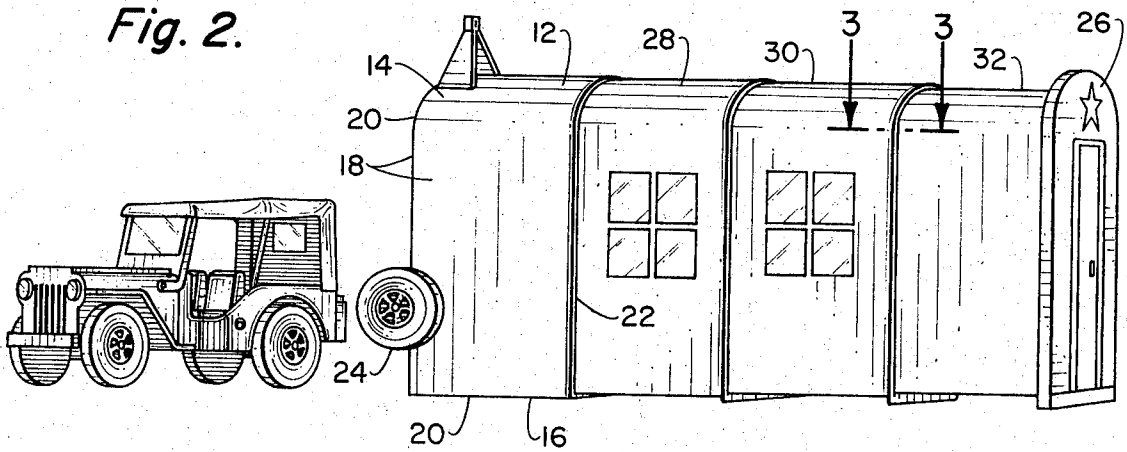
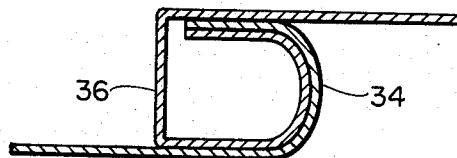

Fig. 3.



FLOATABLE, TELESCOPING, TRANSPORTABLE SHELTER

BACKGROUND OF THE INVENTION

1. Field of the Invention

The present invention relates, generally, to transportable telescoping shelters and, more specifically, to such shelters that may float when transported and achieve maximum stability when operational.

2. Description of the Prior Art

There are numerous telescoping trailers, campers, etc., mounted on wheels for ease of transportation. Elaborate support means must be employed as such prior art devices do not sit on the ground. Also, maximum stability of the shelter is not achieved since the center of gravity of such shelter is not as close to the ground as it could be. Also, due to the heavy weight of the telescoping sections, complex and custom designed extension means must be employed. In addition, such shelters are limited to being transported on land. They cannot be transported on water without having specially designed, flotation equipment attached thereto.

There exists a need for a shelter that can be unloaded from a ship, floated ashore, transported across wind-swept land, and there placed in operational use. Such a shelter needs to be water-tight, lightweight, exhibit good thermal insulation properties, and have stability.

SUMMARY OF THE INVENTION

The general purpose of the present invention is to provide a floatable, telescoping, transportable shelter that has greater stability, is easier and faster to erect, is less expensive, is less complex, is lighter, and possesses greater transporting flexibility than prior art transportable shelters. To attain this, the present invention includes an end section containing a plurality of telescoping middle sections which are manually pulled therefrom to form the shelter. A bulkhead provides a cover for the end section when the shelter is being transported and a closure member for the last telescoped middle section when the shelter is operational. Means are provided for rendering the shelter water-tight at all times. Wheels are removably attached to a side of the end section, so that the shelter must be tipped over on its bottom in order to manually slide the telescoping middle sections out, thereby providing easily removable wheels and imparting maximum achievable stability to the shelter.

Accordingly, one object of the present invention is to provide a floatable shelter.

Another object of the present invention is to provide a telescoping shelter.

Another object of the present invention is to provide a transportable shelter.

Another object of the present invention is to provide a shelter having maximum stability.

Another object of the present invention is to provide a shelter having a low center of gravity.

Another object of the present invention is to reduce complexity, cost, and weight.

Another object of the present invention is to eliminate detachable, external support members.

Another object of the present invention is to provide a shelter capable of being transported on land and water.

Another object of the present invention is to eliminate the need for a dock to unload the shelter onto from a ship.

Another object of the present invention is to provide a shelter capable of easy and fast erection.

Another object of the invention is to provide transporting flexibility.

Another object of the present invention is to provide a shelter that has no loose bolts, pins, or framing members which can be lost, stolen, or misplaced.

Another object of the present invention is to provide a shelter that has good thermal insulation.

Another object of the present invention is to provide a water-tight shelter when operational.

Other objects and a more complete appreciation of the present invention and its many attendant advantages will develop as the same becomes better understood by reference to the following detailed description when considered in connection with the accompanying drawings in which like reference numerals designate like parts throughout the figures thereof and wherein:

BRIEF DESCRIPTION OF THE DRAWINGS

FIG. 1 is an isometric view of the present invention in land transporting configuration.

FIG. 2 is an isometric view of the present invention in operational configuration.

FIG. 3 is a cross-sectional view of the sealing means between the telescoping sections of FIG. 2.

DESCRIPTION OF THE PREFERRED EMBODIMENT

Referring to FIG. 1, floatable, telescoping, transportable shelter 10 is shown in collapsed form. End section 12, having a top 14, a bottom 16, and three sides 18, has a water-tight seal 20 at the intersections of top 14, bottom 16, and three sides 18. End section 12 also has an edge 22. Bottom 16 is physically disposed in a vertical plane when shelter 10 is being transported and in a horizontal plane when shelter 10 is operational (FIG. 2). End section 12 forms a water-tight hull for transporting shelter 10 on water. Attached to one of three sides 18 are a pair of wheels 24. Wheels 24 are removable. Thus, shelter 10 can be lowered into the water from a ship using a crane, floated to shore, wheels 24 attached, and then transported overland to a remote location.

Now referring to FIG. 2, telescoping middle sections 28, 30, and 32 are shown extended in telescopic fashion. A bulkhead 26 is attached to the open end of middle section 32.

Bulkhead 26 serves as a closure member for shelter 10 when in operational form and, also, as a closure member that attaches to edge 22 of end section 12 when shelter 10 is being transported. Attached to bulkhead 26 are two lips (not shown). One lip fits over edge 22 to effect a water-tight seal therewith so that shelter 10 may be floated in water. A second lip fits over an edge of middle section 32 to effect a water-tight seal therewith.

Means for providing water-tight seals between middle sections 30 and 32, 28 and 30, and between end section 12 and middle section 28 are shown in FIG. 3.

A seal 36 slides into a lip 34 to effect a water-tight seal between middle sections 30 and 32, 28 and 30, and between end section 12 and middle section 28 when shelter 10 is operational.

A gasket of resilient material (not shown) may be inserted between seal 36 and lip 34 to effect a more effective water-tight seal, if desired.

Bulkhead 26 is removably hinged to end section 12, as shown in FIG. 1.

Shelter 10 may be fabricated in a wide range of sizes in preformed or built-up lightweight panels using a tough fiberglass skin and lightweight insulating styrofoam or honeycomb core, or other suitable materials well known to those skilled in the art that are water-tight and provide good thermal insulation.

Shelter 10 is transported to a location as shown in FIG. 1. Bulkhead 26 is removed. End section 12 is then tipped over on bottom 16, as shown in FIG. 2. Wheels 24 may be removed at this point. Telescoping middle sections 28, 30, and 32 are pulled out of end section 12 and fully extended, as shown in FIG. 2. Bulkhead 26 is then attached to the open end of middle section 32 thereby effecting the closure of shelter 10. Doors and windows are provided where required. By tipping shelter 10 over its center of gravity assumes the lowest possible position, thereby providing maximum stability to shelter 10. This stability is critical in harsh wind-swept environments where no adequate natural windbreaks exist.

The specific embodiment shown in FIG. 1 is erectable by two men and is ready for occupancy in fifteen minutes. It can be taken down to its transporting configuration by two men within 10 minutes. There are no loose bolts, pins, or framing members which can be lost, stolen, or misplaced, and no tools of any kind are required for erection or repacking.

Obviously, numerous modifications and variations of the present invention are possible in light of the above teachings. It is therefore to be understood that within the scope of the appended claims the invention may be practiced otherwise than as specifically described herein.

We claim:

1. A floatable, telescoping, transportable shelter comprising:

- a. an end section having a top, a bottom, three sides, and an edge, said bottom being physically disposed in a horizontal plane when said shelter is operational and being physically disposed in a vertical

plane when said shelter is being transported;

- b. a plurality of telescoping middle sections, each having a first and a second edge including a last middle section, said middle sections being contained in said end section when said shelter is being transported, said middle sections protrude out of said end section when said shelter is operational, one said middle section being attached to said edge of said end section;

- c. a removable bulkhead being attached to and completely covering the open end of said end section when said shelter is being transported and being attached to and completely covering the last middle section when said shelter is operational; and

- d. a plurality of removable wheels connected to a side of said end section whereby said shelter is easily transported over land, said shelter being tipped over on said end section's bottom when operational whereby said wheels are easily removable and said shelter attains maximum stability.

2. The shelter of claim 1 further comprising a removable hinge connected between said bulkhead and a side of said end section.

3. The shelter of claim 1 further comprising means for rendering said shelter water-tight when being transported and when operational.

4. The shelter of claim 3 wherein said means for rendering said shelter water-tight includes:

- a. a water-tight seal formed at the intersections of said bottom, said top, and said three sides of said end section;
- b. a plurality of seals, one each attached to said first edges of said middle sections;
- c. a plurality of lips, one each attached to said second edges of said middle sections and to said edge of said end section in such manner that said lips receive said seals when said shelter is extended for operations such that a water-tight junction is effected therebetween; and

- d. a first and second lip attached to said bulkhead, said first lip forming a water-tight seal with the end telescoping middle section, said second lip forming a water-tight seal with the edge of said end section.

5. The shelter of claim 1 wherein said plurality of telescoping middle sections comprise a first middle section, a second middle section, and a third middle section.

* * * * *

50

55

60

65