



(43) International Publication Date
18 August 2016 (18.08.2016)

(51) International Patent Classification:

G01S 5/14 (2006.01) H04W 4/02 (2009.01)
G01S 19/42 (2010.01) H04W 64/00 (2009.01)

(21) International Application Number:

PCT/US2016/016581

(22) International Filing Date:

4 February 2016 (04.02.2016)

(25) Filing Language:

English

(26) Publication Language:

English

(30) Priority Data:

62/113,700 9 February 2015 (09.02.2015) US

(71) Applicant: **CONCENTRIC REAL TIME, LLC** [US/US]; 3217 Green Forest Court, Ellicott City, MD 21042 (US).

(72) Inventors: **BOVARD, Reese, Steele**; 3217 Green Forest Court, Ellicott City, MD 21042 (US). **JENSEN, Eric, John**; 2242 Cherokee Drive, Westminster, MD 21157-7800 (US).

(74) Agents: **THORSTAD-FORSYTH, Carol, E.** et al.; Fox Rothschild LLP, 222 Lakeview Avenue, Suite 700, West Palm Beach, FL 33401 (US).

(81) Designated States (unless otherwise indicated, for every kind of national protection available): AE, AG, AL, AM,

AO, AT, AU, AZ, BA, BB, BG, BH, BN, BR, BW, BY, BZ, CA, CH, CL, CN, CO, CR, CU, CZ, DE, DK, DM, DO, DZ, EC, EE, EG, ES, FI, GB, GD, GE, GH, GM, GT, HN, HR, HU, ID, IL, IN, IR, IS, JP, KE, KG, KN, KP, KR, KZ, LA, LC, LK, LR, LS, LU, LY, MA, MD, ME, MG, MK, MN, MW, MX, MY, MZ, NA, NG, NI, NO, NZ, OM, PA, PE, PG, PH, PL, PT, QA, RO, RS, RU, RW, SA, SC, SD, SE, SG, SK, SL, SM, ST, SV, SY, TH, TJ, TM, TN, TR, TT, TZ, UA, UG, US, UZ, VC, VN, ZA, ZM, ZW.

(84) Designated States (unless otherwise indicated, for every kind of regional protection available): ARIPO (BW, GH, GM, KE, LR, LS, MW, MZ, NA, RW, SD, SL, ST, SZ, TZ, UG, ZM, ZW), Eurasian (AM, AZ, BY, KG, KZ, RU, TJ, TM), European (AL, AT, BE, BG, CH, CY, CZ, DE, DK, EE, ES, FI, FR, GB, GR, HR, HU, IE, IS, IT, LT, LU, LV, MC, MK, MT, NL, NO, PL, PT, RO, RS, SE, SI, SK, SM, TR), OAPI (BF, BJ, CF, CG, CI, CM, GA, GN, GQ, GW, KM, ML, MR, NE, SN, TD, TG).

Published:

- with international search report (Art. 21(3))
- before the expiration of the time limit for amending the claims and to be republished in the event of receipt of amendments (Rule 48.2(h))

(54) Title: RADIO RECEIVER FOR DETERMINING LOCATION OF A SIGNAL SOURCE

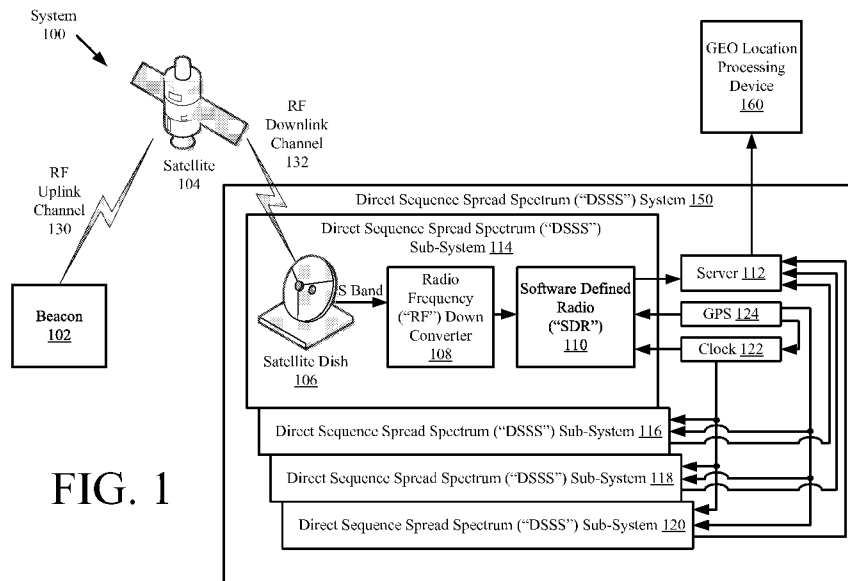

FIG. 1

(57) Abstract: Systems and methods for determining an accurate location of a signal's source of transmission. The methods involve: demodulating a detected carrier signal modulated with a Pseudo Noise ("PN") code sequence to obtain an original information-bearing signal therefrom; computing time delay offsets using correlations of PN code windows for each symbol of the original information-bearing signal; determining a high accuracy Time Of Arrival ("TOA") of the detected carrier signal using the time delay offsets; and using the high accuracy TOA to determine an accurate location of the original information-bearing signal's source of transmission.

WO 2016/130399 A1

RADIO RECEIVER FOR DETERMINING LOCATION OF A SIGNAL SOURCE

CROSS-REFERENCE TO RELATED APPLICATIONS

[0001] This application claims priority to U.S. Patent Application No. 62/113,700, filed February 9, 2015. The contents of the above application are incorporated by reference in its entirety.

FIELD OF THE INVENTION

[0002] This document relates generally to radio receivers. More particularly, this document relates to systems and methods for providing a radio system capable of determining a source location of a signal with high accuracy.

BACKGROUND

[0003] A Software Defined Radio (“SDR”) is a programmable and reconfigurable system that provides a flexible and scaleable architecture. Such a radio system typically supports many different communication waveforms, thus facilitating improved communications among users, such as government agencies and government services. An SDR typically comprises a single hardware platform that can carry out many functions based on the software applications loaded therein. The SDR uses the installed software applications to perform radio signal processing functions. Frequency tuning, filtering, synchronization, encoding and modulation are performed in software on high-speed reprogrammable devices (e.g., Digital Signal Processors (“DSPs”), Field Programmable Gate Arrays (“FPGAs”) and General Purpose Processors (“GPPs”).

[0004] At the center of SDR technology is the software architecture on which the radios must be built and communication protocols implemented. Many proprietary architectures exist, but to ensure portability and interoperability of the protocols on the different radios, an open architecture was developed. The open architecture is referred to as a Software Communications Architecture (“SCA”). SCA comprises a set of specifications describing the interaction between the different software and hardware components of a radio and providing software commands for

their control. Accordingly, the SCA is an open architecture framework that specifies how hardware and software components are to interoperate so that different manufacturers and developers can readily integrate the respective components into a single device.

SUMMARY OF THE INVENTION

[0005] The present document concerns systems and methods for determining an accurate location of a signal's source of transmission. The methods comprise: demodulating, by a receiver of a communication device, a detected carrier signal modulated with a Pseudo Noise ("PN") code sequence to obtain an original information-bearing signal therefrom; computing, by the receiver, time delay offsets using correlations of PN code windows for each symbol of the original information-bearing signal; determining, by the receiver, a high accuracy Time Of Arrival ("TOA") of the detected carrier signal using the time delay offsets; and using, by the receiver, the high accuracy TOA to determine an accurate location of the original information-bearing signal's source of transmission.

[0006] In some scenarios, the demodulating comprises: detecting a phase deviation from the detected carrier signal; removing the phase deviation from the detected carrier signal; performing early/late gate tracking to recover symbol timing phase of the detected carrier signal; and performing demodulation of the detected carrier signal using the recovered symbol timing thereof to extract the original information-bearing signal therefrom.

[0007] In those or other scenarios, the method further comprise: curve fitting the time delay offsets to construct a fitted curve that has a best fit to a series of data points defining the time delay offsets; and extrapolating unknown time delay offsets using the fitted curve. The high accuracy TOA is determined using the unknown time delay offsets that were extrapolated using the fitted curve. The high accuracy TOA is refined by: determining a satellite position; computing an atmospheric and relativistic delay that affected the detected carrier signal during transmission thereof using the satellite position; and applying the atmospheric and relativistic delay to the high accuracy TOA so as to generate a refined TOA. The refined TOA is then used to determine an accurate location of the original information-bearing signal's source.

[0008] In those or other scenarios, the high accuracy TOA is determined by: determining through signal detection, a coarse TOA and a coarse Frequency Of Arrival (“FOA”) for a sample of the original information-bearing signal; performing a multi-stage down conversion process using at least the samples associated with the coarse FOA at the point of detection to remove a Doppler effect from the original information-bearing signal; cross correlating a first set of samples from the original information-bearing signal to a second set of samples from a local copy of the PN code sequence to determine a cross correlation peak; using the cross correlation peak to find a first temporal peak center for a pulse for each symbol of the original information-bearing signal; using the correlation peak to find a first temporal peak center for each symbol of the original information-bearing signal; using the first temporal peak center to obtain a set of first estimated symbols; using the set of first estimated symbols to obtain a value representing twice a center frequency; and down converting the set of samples using the center frequency to remove any remaining trace of Doppler effect from the original information-bearing signal.

[0009] The high resolution TOA process comprises: obtaining a correlation peak by cross correlating a third set of samples obtained from the original information-bearing signal with the removed Doppler effect to a fourth set of samples obtained from the local copy of the PN code sequence; using the second temporal peak center to obtain a set of second estimated symbols; generating a curve fit using the set of second estimated symbols; and determining the high accuracy TOA by dividing an intercept value of a sample-by-sample rate, where the intercept value is obtained using the curve fit and the samples associated with the coarse TOA.

DESCRIPTION OF THE DRAWINGS

[0010] Embodiments will be described with reference to the following drawing figures, in which like numerals represent like items throughout the figures, and in which:

[0011] FIG. 1 comprises a schematic illustration of an exemplary system that is useful for understanding the present invention.

[0012] FIG. 2 comprises a schematic illustration of an exemplary architecture for an SDR shown in FIG. 1.

[0013] FIG. 3 comprises a schematic illustration outlining functional operations of signal processing performed by the SDR shown in FIGS. 1-2.

[0014] FIG. 4 comprises a detailed block diagram schematically illustrating the acquisition operations of a functional block shown in FIG. 3.

[0015] FIG. 5 provides a plurality of graphs that are useful for understanding the present invention.

[0016] FIG. 6 comprises a detailed functional block diagram that is useful for understanding the signal detection operations employed herein.

[0017] FIG. 7 comprises a detailed functional block diagram that is useful for understanding the correlator processing employed herein.

[0018] FIG. 8 provides a schematic illustration that shows peaks refined using a higher resolution FFT.

[0019] FIG. 9 comprises detailed functional block diagram that is useful for understanding the de-spreading and demodulation operation employed herein.

[0020] FIG. 10 comprises a schematic illustration illustrating tracking loop interaction with tuning and resampling.

[0021] FIG. 11 comprises a flow diagram of an exemplary method for determining a Time Of Arrival (“TOA”).

[0022] FIGS. 12 and 13 each comprise a plurality of graphs that are useful for understanding exemplary filtering operations employed for determining a TOA.

[0023] FIG. 14 comprises a schematic illustration that is useful for understanding exemplary cross correlation operations employed for determining a TOA.

[0024] FIG. 15 comprises a graph plotting one symbol correlation over a sample window.

[0025] FIG. 16 comprises a graph that is useful for understanding an interpolated symbol peak.

[0026] FIG. 17 comprises graphs that are useful for understanding how a symbol is found using best symbol peaks.

[0027] FIG. 18 comprises a schematic illustration that is useful for understanding how the frequency of a window of K symbols is determined.

[0028] FIG. 19 comprises a schematic illustration that is useful for understanding how a set of K symbols is integrated.

[0029] FIG. 20 provides a graph showing integrated peak values over K symbols.

[0030] FIG. 21 comprises a graph showing integrated correlation peak values over K symbols.

[0031] FIG. 22 comprises a graph showing a curve fit of symbols peak sample offsets.

[0032] FIG. 23 comprises graphs that are useful for understanding time dilation and contraction.

[0033] FIG. 24 is a flow diagram of an exemplary method for determining a high accuracy TOA.

[0034] FIG. 25 is a flow diagram of an exemplary method for understanding a high resolution TOA process.

DETAILED DESCRIPTION OF THE INVENTION

[0035] It will be readily understood that the components of the embodiments as generally described herein and illustrated in the appended figures could be arranged and designed in a wide variety of different configurations. Thus, the following more detailed description of various embodiments, as represented in the figures, is not intended to limit the scope of the present disclosure, but is merely representative of various embodiments. While the various aspects of

the embodiments are presented in drawings, the drawings are not necessarily drawn to scale unless specifically indicated.

[0036] The present invention may be embodied in other specific forms without departing from its spirit or essential characteristics. The described embodiments are to be considered in all respects only as illustrative and not restrictive. The scope of the invention is, therefore, indicated by the appended claims rather than by this detailed description. All changes which come within the meaning and range of equivalency of the claims are to be embraced within their scope.

[0037] Reference throughout this specification to features, advantages, or similar language does not imply that all of the features and advantages that may be realized with the present invention should be or are in any single embodiment of the invention. Rather, language referring to the features and advantages is understood to mean that a specific feature, advantage, or characteristic described in connection with an embodiment is included in at least one embodiment of the present invention. Thus, discussions of the features and advantages, and similar language, throughout the specification may, but do not necessarily, refer to the same embodiment.

[0038] Furthermore, the described features, advantages and characteristics of the invention may be combined in any suitable manner in one or more embodiments. One skilled in the relevant art will recognize, in light of the description herein, that the invention can be practiced without one or more of the specific features or advantages of a particular embodiment. In other instances, additional features and advantages may be recognized in certain embodiments that may not be present in all embodiments of the invention.

[0039] Reference throughout this specification to “one embodiment”, “an embodiment”, or similar language means that a particular feature, structure, or characteristic described in connection with the indicated embodiment is included in at least one embodiment of the present invention. Thus, the phrases “in one embodiment”, “in an embodiment”, and similar language throughout this specification may, but do not necessarily, all refer to the same embodiment.

[0040] As used in this document, the singular form “a”, “an”, and “the” include plural references unless the context clearly dictates otherwise. Unless defined otherwise, all technical and scientific terms used herein have the same meanings as commonly understood by one of ordinary skill in the art. As used in this document, the term “comprising” means “including, but not limited to”.

[0041] The present solution implements methods for computing a TOA and an FOA of a signal transmitted from a beacon, relayed off a satellite and received at a ground station. The terms “Time Of Arrival” and “TOA”, as used herein, refers to the travel time of a signal sent from a first communication device (e.g., a beacon) and received at a second communication device (e.g., a ground station). The terms “Frequency Of Arrival” and “FOA”, as used herein, refers to the frequency at which a signal is received by a remote ground station. The accuracy of the TOA is directly proportional to the accuracy of the beacon location estimate. Therefore, the present solution provides a novel technique to compute a high accuracy TOA for the purpose of improving the beacon location estimate.

[0042] In some scenarios, the novel technique is employed in an SDR receiver. The SDR receiver is configured to perform signal detection (e.g., block 304 of FIG. 3), signal demodulation (e.g., operational block 306 of FIG. 3), and obtain high accuracy TOA measurements in a dynamic Doppler environment (e.g., operational block 308 of FIG. 3). The particulars of each of these operations will be described in detail below. Notably, in the present solution, one hundred (100) ns measurement accuracy is possible due to the combination of signal processing and access to atmospheric data and satellite ephemeris. The accuracy is a three (3) orders of magnitude improvement over existing search and rescue receivers.

[0043] The signal detection is done using a Fast Fourier Transform (“FFT”) correlation process that allows for signal detection over a range of Doppler frequencies. A coarse TOA is computed during the signal detection process.

[0044] Signal demodulation is achieved by: (1) detecting a phase deviation from a detected carrier signal (modulated with a Pseudo Noise (“PN”) code sequence) due to satellite movement; (2) removing the phase deviation from the detected carrier signal; (3) performing early/late gate

tracking to recover symbol timing phase of the detected carrier signal using an early/late gate algorithm; and (4) performing demodulation of the detected carrier signal using the recovered symbol timing thereof to extract the original information-bearing signal therefrom. Early/late gate algorithms are well known in the art, and therefore will not be described herein. Any known or to be known early/late gate algorithm can be used herein without limitation. The fundamental goal of the early/late gate tracking is to facilitate symbol synchronization so that a pulse can be sampled at its peak value as described below. There are several ways of demodulation which can be employed herein depending on how parameters of a baseband signal (such as amplitude, frequency or phase) are transmitted in the carrier signal. Any known or to be known demodulation technique can be employed herein that is suitable for demodulating a given modulated carrier wave.

[0045] The high accuracy TOA is obtained by: (1) computing time delay offsets using correlations of PN code windows for each symbol of the original information-bearing signal; (2) curve fitting the time delay offsets to construct a fitted curve (or mathematical function) that has the best fit to a series of data points defining the time delay offsets; (3) extrapolating unknown time delay offsets using the fitted curve; and (4) determining a high accuracy TOA of the detected modulated carrier signal using the time delay offsets and/or the unknown time delay offsets extrapolated using the fitted curve. The terms “pseudo noise code window” and “PN code window”, as used herein, refers to a sequence of n bits contained in the pseudo noise code, where n is an integer. Two PN code windows may comprise at least one same bit (i.e., comprise overlapping portions of the PN code) or none of the same bits (i.e., comprise non-overlapping portions of the PN code). The curve fitting can include, but is not limited to, interpolation and/or smoothing. The curve enables the ability to infer values of a function where no data is available. The extrapolating involves using the fitted curve beyond the range of observed data to estimate the value of a variable (e.g., an unknown time delay offset value for a first symbol) on the basis of its relationship with another variable (e.g., a known time delay offset of at least a second symbol).

[0046] Further refinement of the high accuracy TOA is accomplished by: (1) determining the satellite position; (2) computing the atmospheric and relativistic delay that affected the detected

modulated carrier signal during transmission thereof using the satellite position; and (3) applying the atmospheric and relativistic delay delays to the high accuracy TOA.

[0047] Referring now to FIG. 1, there is provided a schematic illustration of an exemplary system **100** that is useful for understanding the present invention. System **100** comprises a beacon **102**, a satellite **104**, a Direct Sequence Spread Spectrum (“DSSS”) system **150**, and a GEO location processing device **160**. The beacon **102** can include, but is not limited to, a hand-held communication device, a ship mounted communication device, and/or an aircraft mounted communication device. In all scenarios, the beacon **102** is configured to transmit an alert signal signifying a distress condition.

[0048] When an alert signal is transmitted from the beacon **102** as a DSSS signal, it is received at the satellite **104** on a Radio Frequency (“RF”) uplink channel **130**. The satellite **104** re-transmits the alert signal unmodified (bent pipe) using an RF downlink channel **132**. DSSS signals are well known in the art, and therefore will not be described in detail herein. Still, it should be understood that, in some scenarios, the DSSS signal is formed by multiplying a high rate Pseudo Noise (“PN”) code with a lower rate data signal. PN codes are well known in the art, and thus will not be described herein. Any known or to be known PN code can be used herein without limitation. The multiplying process results in spreading the data signal energy over a wider bandwidth than is needed by the low rate signal. The purpose of this spreading is to allow the coexistence of the new signal with other signals with minimal interferences therebetween.

[0049] The DSSS signal is then received by the DSSS system **150**. The DSSS system **150** processes the received DSSS signal for determining a TOA and/or an FOA therefore. The novel manner in which the TOA and/or FOA are determined will become more evident as the discussion progresses. The TOA and/or FOA are(is) then stored for subsequent use by the GEO location processing device **160** to determine an accurate location of the beacon **102** relative to the DSSS system **150**.

[0050] As shown in FIG. 1, the DSSS system **150** comprises a plurality of DSSS sub-systems **114**, **116**, **118**, **120**. The present invention is not limited in this regard. The DSSS

system **150** can include any number of DSSS sub-systems as is required for a particular application. For example, the DSSS system **150** can include a single DSSS sub-system or N DSSS sub-systems, where N is an integer. However, the accuracy of the beacon **102** location increases as the number of redundant DSSS sub-systems increases.

[0051] In all cases, timing components **122** and **124** provide an accurate time base for the DSSS sub-system(s). For example, the timing components include a GPS receiver **124** and a clock **122**. The GPS receiver **124** provides a one (1) pulse per second signal that is accurate to fifty (50) ns of Coordinated Universal Time (“UTC”) and a ten (10) MHz reference signal that has very low phase noise and is frequency stable to point zero one parts per billion (1 e-11 or 0.01 Parts Per Billion). In addition, the clock **122** (e.g., a network time server) provides a time tag that is accurate to ten (10) ms. The combination of these two elements **122** and **124** provides a fifty (50) ns accurate time reference for the DSSS sub-system(s). The present invention is not limited to the particulars of this example. Still, it should be understood that any known or to be known time referencing scheme can be used herein without limitation, provided that the time reference is equal to or less than fifty (50) ns from the actual UTC time and is provided coherently to the DSSS sub-systems **114-120**.

[0052] Each of the DSSS sub-systems comprises a satellite dish **106**, an RF down converter **108**, and an SDR **110**. RF down converters are well known in the art, and therefore will not be described herein. Any known or to be known RF down converter can be used herein which is configured to at least receive signals in either an S band or an L band. In some scenarios, the RF down converter **108** filters, amplifies and down converts the received DSSS signal to an Intermediate Frequency (“IF”) signal (e.g., a 70 MHz IF signal). The IF signal is then provided to the SDR **110** for digital processing. The RF down converter **108** and SDR **110** are driven by the GPS receiver **124** time reference to maintain coherence.

[0053] A schematic illustration of an exemplary architecture for the SDR **110** is provided in FIG. 2. As shown in FIG. 2, SDR **110** includes an antenna **202** that is coupled to an antenna feed system **204** for routing received signals to a receiver **206**. Receiver **206** can include any one of a wide variety of broadband receiver systems as are commonly known in the field of SDRs. In this

regard, the receiver **206** can include, but is not limited to, one or more stages of RF amplifiers and filters. Depending on the design of the SDR system, the receiver **206** can also include one or more mixing stages, IF amplifiers and IF filter stages. One or more RF or IF output channels are communicated from the receiver **206** to one or more Analog to Digital (“A/D”) converters **208**. Once the incoming analog signal has been converted to a digital signal by the A/D converter(s) **208**, it is passed to the digital section **250** of the SDR **110** for any necessary receiver digital signal processing.

[0054] Receiver digital signal processing is performed in digital receiver processing unit **210** of the digital section **250**. The digital receiver processing unit **210** is comprised of a programmable microprocessor, general purpose computer programmed with a set of instructions or any other electronic circuitry suitable for performing the functions as described herein. In some scenarios, the digital receiver processing unit **210** comprises a microprocessor programmed with a suitable set of instructions for performing the various functions described herein.

[0055] The receiver digital signal processing includes: frequency shifting an IF signal to a baseband signal (e.g., shift a signal’s frequency from 70 MHz to 0 Hz); and filtering the baseband signal to remove duplicative products. The filtering can be achieved using a Finite Impulse Response (“FIR”) filter. FIR filters are well known in the art, and therefore will not be described herein.

[0056] At the same time, the IF signal is down converted. The resulting samples are stamped with a time tag Epoch. The sample that occurs at the same instant as the current second (as defined by a time reference signal, such as a GPS 1 PPS signal) is attached to a time tag (e.g., the number of seconds since a given date, such as January 1, 2012). Each subsequent sample is then offset by the inverse of the sample frequency.

[0057] Once the signal is acquired at baseband during a signal acquisition **302**, various other signal processing operations are performed by the SDR **110**. As shown in FIG. 3, these operations involve: performing signal detection **304**; performing signal demodulation **306**; performing a TOA/FOA determination process **308**; and performing location processing **310**. Each of these operations **304-310** will be discussed in detail below.

[0058] The signal detection process 304 is performed by the digital receiver processing unit 210 using an FFT correlation process. The FFT correlation process allows for detection over a range of Doppler frequencies. The FFT correlation process involves: (a) computing a coarse TOA; (b) performing a sample-by-sample correlation of the baseband signal with a replica of the PN code sequence used to modulate the carrier signal; and (c) performing an FFT using the results of the sample-by-sample correlation. In step (a), the coarse TOA is computed by analyzing time information contained in the baseband signal to determine the travel time for the original information-bearing signal transmitted from the beacon (e.g., beacon 102 of FIG. 1) to the ground station (e.g., DSSS system 150 of FIG. 1). In step (b), the spread energy is collapsed into a narrow peak when the replica and the received carrier signal overlap in time. Since a satellite (e.g., satellite 104 of FIG. 1) is moving (i.e., it is not geostationary) and causes Doppler shifts in the carrier signal, the carrier signal cannot be shifted exactly to baseband without knowledge of the beacon position 102. For this reason, an FFT is employed after the sample-by-sample correlation which has the effect of revealing the peak at the actual resulting Doppler offset frequency.

[0059] When a successful sample-by-sample correlation is performed, the peak of a pulse for each symbol of the spread spectrum signal needs to be detected. The peak is detected using an exponential averaging of the FFT data. Each time an FFT is performed, the new FFT data is exponentially averaged and smoothed with the previous FFT's. This is a measure of the average ambient energy in the band. A threshold can be obtained by multiplying a constant value to the value of the average ambient energy. The threshold can then be used for peak detection. The detected peak is quantified as: (i) a sample offset (i.e., the number of samples from the most recent second); (ii) the frequency offset within the current FFT; and (iii) the magnitude of the peak. These values (i)-(iii) are then stored in a memory 228 for later use.

[0060] The detected peak and time-tagged baseband samples are then used in a subsequent signal demodulation process 306 by the SDR 110. The signal demodulation process 306 involves detecting and removing a residual frequency offset and a residual phase deviation from the signal. The residual frequency and phase offsets are detected by first de-spreading the signal. The de-spreading is achieved by: looking up an appropriate baseband sample given a time-tag

and a sample offset; down converting the spread spectrum signal to 0 Hz using a frequency offset to remove Doppler; de-spreading the spread spectrum signal using small symbol size chunks of the replica of the baseband signal's PN code; and integrating oversampled de-spread samples to form a symbol. Once the de-spreading process is completed, the symbol is FFT'ed to determine a residual frequency offset. The residual frequency offset is removed from the signal by frequency shifting the signal to baseband. In addition, the residual phase deviation (due to satellite movement during the burst) is detected and removed. Thereafter, the above-described process is repeated for a next time-tagged baseband sample. Upon completing the previously described iterative process, the symbols are mapped into bits using a lookup table.

[0061] As noted above, the signal demodulation process **306** also involves performing early/late gate tracking and demodulation. The early/late gate tracking involves computing time delay offsets for each symbol. The time delay offsets are computed using early/late gate correlations of PN code windows for each symbol. More specifically, the results of the early/late gate correlations are curve fit and extrapolated. The result of the extrapolation is used to compute a high accuracy TOA (a refined version of the previously determined coarse TOA) during the TOA/FOA computation process **308**.

[0062] During the signal demodulation process **306**, each sub chunk of the PN code is correlated with a window of samples in the spread spectrum signal. This forms an early/late gate detection of each symbol and identifies the appropriate sample instant for a particular symbol by maximizing the energy. The energy is maximized by picking the maximum energy correlation shift. The maximum energy correlation shift is recorded for each symbol so that a set of relative time tags over the signal burst are recorded. The set of time tags can then be curve (linear or higher order depending on the dynamics of the satellites or transmitter) fit using the mean square error method. The burst TOA is the intercept of the function.

[0063] Once the message bits and TOA are computed, a further refinement to the TOA is accomplished during the TOA/FOA computation process **308**. The refinement is achieved by: determining the satellite position; computing the atmospheric and relativistic delay that affected the detected modulated carrier signal during transmission thereof; and applying the atmospheric

and relativistic delay to the high accuracy TOA. This can be performed using a freely available software package referred to as the GPSToolkit®. The GPSToolkit® contains software algorithms that compute a satellite position, a relativistic effect and an Ionosphere delay when inputting the satellite ephemeris, time of day and location of a receiver.

[0064] In computing the uplink delay, the satellite group delay bias must be accounted for in order to predict the time of arrival at the satellite and in turn the high accuracy time of transmission. This is done by performing a calibration process using a known transmit position, receive position and the ephemeris of the satellites. The calibration process is performed to calculate the delays and to statistically determine the unknown delay of the satellite. The time of flight from the beacon (e.g., beacon **102** of FIG. 1) to the DSSS sub-system (e.g., DSSS sub-system **114** of FIG. 1) is calculated by calculating the satellite position using the SP3 ephemerides. The ionosphere and troposphere delays are calculated once the pierce point in the atmosphere of the signal's path is determined. The difference between the measured time and the predicted time yields the satellite group delay bias. A large sampling of the group delay bias is taken while a satellite is at an elevation above forty (40) degrees and preferably when the ionosphere delays are at a minimum. This is achieved by taking the samples when the sun's position is over the horizon of the region of the transmitter and receiver. At least a one hundred (100) ns measurement accuracy is possible due to the combination of signal processing and access to atmospheric data and satellite ephemeris. The accuracy is three (3) orders of magnitude improvement over existing Search and Rescue receivers.

[0065] As also shown in FIG. 2, the SDR **110** additionally includes a power supply **220** for providing power to the various digital and analog blocks that comprise the system. The SDR **110** can also include a control processor **222**. Similar to the digital receiver processing unit **210**, the control processor **222** can be comprised of a programmable microprocessor, general purpose computer programmed with a set of instructions or any other electronic circuitry suitable for performing the functions as described herein. In some scenarios, the control processor is a microprocessor programmed with a suitable set of instructions for performing the various functions described herein.

[0066] Control processor **222** includes data communications ports for communicating control signals to one or more component systems forming the SDR **110**. The communications ports can be coupled to any suitable type of conventional computer data communication bus **226**. The computer data communication bus **226** can be used to communicate control signals from the control processor **222** to one or more of the SDR subsystems as hereinafter described.

[0067] The control processor is also operatively coupled to a user interface **224**. User interface **224** can be implemented using a display (not shown) for presenting a Graphical User Interface (“GUI”). The display can be a Liquid Crystal Display (“LCD”) or any other display suitable for use on a mobile station. The display can be black and white or color. The user interface **224** also advantageously includes a user input device. The user input device can include a keypad, a touch pad, buttons, switches, sensors, and/or any other devices which can be used to receive user inputs.

[0068] The SDR architecture shown in FIG. 2 is exemplary. The present invention is not limited to that shown in FIG. 2. For example, in those or other scenarios, the SDR comprises a PC workstation hosting an FPGA/Analog Digital Converter (“ADC”) card. The FPGA/ADC card digitizes and processes the received IF signals. The FPGA/ADC card can include, but is not limited to, a Pentek® Digital Receiver card which performs the following operations: digitizes signals at 200 MHz; timestamps data using a 1 PPS; and performs detection processing. The Pentek® Digital Receiver is installed in a PCI-e slot of the PC workstation, which provides a transparent interface between the registers in the FPGA and the PC workstation. The baseband samples and detections are passed to the PC workstation over the PCI-e interface. The PC workstation accepts the detections and baseband samples, dispreads and demodulates the signals, and presents the results to a location processor. The PC workstation creates an XML file with a specified format and copies the XML file to the appropriate directory in a mapped drive on the server **112**. The present invention is not limited to the particulars of this example.

[0069] Signal Processing

[0070] As noted above, there is provided a schematic illustration outlining the functional operations of the signal processing performed by SDR **110**. The functional operations include:

acquisition operations represented by functional block **302**; signal detection operations represented by functional block **304**; signal de-spreading and demodulation operations represented by functional block **306**; and TOA and/or FOA estimation operations represented by functional block **308**. The TOA and/or FOA estimates are then used in location determination operations to determine the location of the beacon (e.g., beacon **102** of FIG. 1) relative to the DSSS system (e.g., DSSS system **150** of FIG. 1), as shown by functional block **310**. The location determination operations are performed by a GEO location processing device (e.g., GEO location processing device **160** of FIG. 1).

[0071] The acquisition operations of functional block **302** generally involve: receiving digital samples from an RF down converter (e.g., RF down converter **108** of FIG. 1); and processing the digital samples to tune, filter and/or format the same so that the digital samples are at the appropriate rate for subsequent processing. The signal detection operations of functional block **304** generally involve: taking the baseband samples; performing the correlation function to collapse the spread energy into a narrow band Signal to Noise Ratio (“SNR”) peak; comparing the SNR peak against an uncorrelated signal threshold; and creating detection packets consisting of sample of arrival counter and frequency of arrival index, when the peak exceeds the threshold. The signal de-spreading and demodulation operations of functional block **306** generally involve: accepting the detection packets; performing cluster processing to identify sub-peaks from a given burst; reducing the sets of peaks to a discrete set of detections; and serially processing the set of detections to de-spread and demodulate the signal. Additionally, time and frequency information is computed for each symbol during the signal de-spreading and demodulation operations of functional block **306**. The TOA/FOA function **308** will curve fit the TOA and FOA estimates to determine a refined estimate.

[0072] Acquisition

[0073] Referring now to FIG. 4, there is provided a more detailed block diagram schematically illustrating the acquisition operations of functional block **302**. The acquisition operations generally involve converting an S-Band RF signal to baseband digital samples. Preceding an amplifier **404** is an RF down converter **402**. At the RF down converter **402**, at least

a portion (e.g., 20 MHz) of the S-Band RF signal is pre-selected and down-converted into an IF signal (e.g., a 70 MHz IF signal). In the amplifier **404**, amplification (e.g., a 30 dB amplification) is performed to boost the signal power closer to an input level range of an A/D converter **406**. Further gain is available preceding the A/D converter **406**.

[0074] The sample rate of the A/D converter **406** may be selected (e.g., 100 MHz) to allow direct digitization of the IF band pass filtered signal (e.g., a 70 MHz IF band pass filtered **406** MHz band). The clock (e.g., a 100 MHz clock) and S-Band receiver are phase locked to a GPS time reference (e.g., a 10 MHz reference). The bandwidth of the RF block converter is selected to have a value (e.g., 20 MHz) so that the IF is under-sampled. The input to the A/D converter **406** is adjusted so that the total peak aggregate power into the A/D converter **406** is no more than 0 dBm. The samples will be passed through a clock bridge **408**.

[0075] The IF output spectrum of the S-Band receiver is inverted as shown by graph (a) of FIG. 5. When under-sampling at 100 MHz occurs, the A/D converter **406** sees a non-inverted spectrum shown by graph (b) of FIG. 5. After the filtering, down-converting and decimating stages, the output spectrum is band limited to less than 50 kHz and the sample rate is 100 kHz, as shown by graph (c) of FIG. 5.

[0076] The clock bridge **408** decouples the sample rate from a processing rate. This allows full 308 MHz operation of firmware signal processing. A GPS 1 PPS signal **410** is used to reset a sample counter **412** that marks the samples per second.

[0077] An A/D converter loader **414** provides an indication of the input energy to the A/D converter **406**. If the A/D converter **406** is overloaded, an adjustment of the analog gain can be made to compensate therefore by an analog automatic gain controller **416**.

[0078] After the samples pass through the clock bridge **408**, the signal will be base banded and filtered to the DSSS channel bandwidth of a repeater. This will include signal bandwidth as well as guard band for a Doppler and beacon oscillator stability. As shown by functional blocks **418-434**, the filtering and sample rate reduction can be accomplished by a quarter-band filter, complex tuner, a half-band decimator, a Cascade Integrator Comb (“CIC”) decimator and

decimating Finite Impulse Response (“FIR”) compensation filter. The CIC gain feedback component **428** allows for a feedback gain to maximize the dynamic range of the output. The multiple stages of filtering provide an efficient method for base-banding a signal.

[0079] In some scenarios, components **402-406** and **410** are implemented in hardware. Components **408**, **412**, **414**, **418-434** and **432** are implemented in firmware. Components **416**, **424** and **430** are implemented in software. The present solution is not limited in this regard. All or some of the listed components can be implemented as hardware, software or a combination thereof.

[0080] Signal Detection

[0081] Referring now to FIG. 6, there is provided a more detailed block diagram that is useful for understanding the signal detection operations employed herein. Generally, signal detection is broken down into the following two-steps: (1) identification of spread signals in noise through peak detection of the collapsed spread energy; and (2) assessment and refinement of the peak detections to reduce false alarms and increase probability of successful reception. The identification of signals in noise is performed in a correlator processing element **604** in firmware. In some scenarios, the correlator processing element **604** consists of an FFT based correlator which operates on a preamble of the signal. The correlator processing element **604** de-spreads the signal. The FFT coherently integrates and presents a Doppler influenced carrier frequency of an underlying signal.

[0082] The assessment and refinement of the peaks is done in software. When a burst is present, a set of detections may be present depending on the received signal strength. If multiple bursts are present, then multiple sets of detections may be present. A peak finder **606** reduces the clutter in detections to a set of discrete peaks. These peaks are used in conjunction with the identified complex spread samples to further refine the peak in frequency and time resolution.

[0083] A Coordinated Universal Time (“UTC”) time is passed from software to a sample packetizer and timestamper **608** for association with the 1 PPS signal. The SDR’s clock is synchronized to a local time server which guarantees millisecond accuracy to UTC. Once the

UTC time is passed to the firmware, time-stamping will be good to ten (10) nanosecond accuracy.

[0084] In some scenarios, components **602**, **604** and **608** are implemented in firmware. Components **606-612** are implemented in software. The present solution is not limited in this regard. Each of the components **602-612** can be implemented in hardware, software or a combination of both.

[0085] Correlator

[0086] Referring now to FIG. 7, there is provided a more detailed block diagram that is useful for understanding the correlator processing element **604** employed herein. The correlator processing element **604** receives oversampled complex samples from a data acquisition function **702**. The oversampled complex samples is passed to each of two (2) legs of the process **704-712** and **714-722**, which will compute correlated signal plus noise and uncorrelated signal plus noise random variables. A spread signal will be oversampled by a factor of four (4). In each leg, each new sample is passed to one (1) of four (4) correlator blocks, which de-spread 4096-chip frames and coherently integrates 4-sample blocks. A modulated PN spreading code for the particular beacon is held in a volatile memory (e.g., a Random Access Memory (“RAM”) **726**. The modulated PN spreading code may be updated to other desired PN codes and spreading modulations. Another uncorrelated PN code is held in the volatile memory **724** for computation of an uncorrelated output. The resulting stream of 4096 values is passed through a 4096-point FFT **724** or **716**, the output of which is magnitude detected as shown by functional block **708** or **718**. The uncorrelated signal is exponentially averaged. This will be the noise estimate relative to which the signal detection is compared. When the signal exceeds a threshold value above the noise floor, a detection is forwarded to a First In First Out (“FIFO”) operator (as shown by functional block **722**) to be processed for de-spreading/demodulation. A detection consists of the UTC time to the epoch second and corresponding sample offset that the detection occurred and the frequency bin that the peak was present.

[0087] In some scenarios, a 4096 chip correlator is employed. This chip correlator will provide roughly 30 dB of gain to the input signal. This will be adequate for the DASS downlink under a variety of interference scenarios given the anticipated transmit power of a DSSS beacon.

[0088] Clustering

[0089] Detection peaks typically have time and frequency adjacent sub-peaks. The clustering function identifies these clusters and extracts the central peak from the cluster.

[0090] Refinement of Detection

[0091] The central peaks are then used in conjunction with the complex data corresponding to the detected burst to refine the time and frequency estimations from the detector. These refinements are used as aids in the de-spreading/demodulation process. The samples are maintained in a circular buffer referred to as a data server. A request for an array of samples indexed into the circular buffer at a particular time offset is made to the data server. The array is a set of oversampled complex samples. The chip rate of the signal may be 38.4 k Chips Per Second ("CPS"). The data may be sampled at 153.6 k Samples Per Second ("SPS"), which is selected to be four (4) times the chip rate. Using the detected frequency, the data is down-converted and an FFT (e.g., a 16 k point FFT) is performed. From the peak detection bin, the adjacent frequencies are used to find the sub Hz centroid. For increased time resolution, the samples +3 to -3 offset from the peak are parabolically curve fit to find the sub sample time offset. These refinements will be applied to the detection time and frequency values. FIG. 8 provides a schematic illustration that shows peaks refined using a higher resolution FFT.

[0092] De-spreading/Demodulation

[0093] Using the refined frequency from the peak processing component, the burst's samples are ready to be de-spread and demodulated. FIG. 9 provides a functional block diagram for the de-spreading/demodulation operations performed herein. As shown in FIG. 9, the de-spreading/demodulation operations generally involve: down-converting operations performed by a down converter 902; matched filtering operations performed by a matched filter 904; carrier estimation operations performed by a carrier estimator 906; de-spread/demodulation operations

performed by a de-spreader/demodulator **908**; and TOA/FOA estimation operations performed by a TOA/FOA estimator **910**.

[0094] The down-converting operations of the down converter **902** are used to remove most of the Doppler offset using the refined frequency from the peak processing component. The matched filtering operations of the matched filter **904** can be achieved using a lowpass filter to match the Root Raised Cosine (“RRC”) filtering of the beacon signal. The carrier estimation operations of the carrier estimator **906** involve using the whole burst to estimate the carrier phase for each symbol in the preamble and curve fit the results. The result is used as an input to the de-spread operations of the de-spreader/demodulator **908**.

[0095] In some scenarios, resample operations (not shown in FIG. 9) are performed by a re-sampler to reduce the rate of samples per chip. For example, the re-sampler may reduce the rate from four (4) samples per chip to three (3) samples per chip. The re-sampler may also provide early, late and on-time samples for use in the de-spread operations. The re-sampler may further receive an error signal from a chip tracker (not shown in FIG. 9) to adjust the resample rate. The resample offset can be used to interpolate the timestamp for each chip.

[0096] The de-spread operations of the de-spreader/demodulator **908** involve: applying a de-spreading sequence to the early, late, on-time and noise reference samples; accumulating the number of chips in a symbol (spread factor) to produce a reasonable SNR estimation; and sending this information to chip tracking and demodulation components.

[0097] The chip tracking may use the integrated early, late and on-time samples from the de-spread operations to provide an error signal to the re-sampler. A Delay Lock Loop (“DLL”) error comes from taking early - late (or late - early). When phase locked, the on-time is at its peak value, and early and late is equal (difference or error is zero). When the timing is off, the samples slide to the left or right of the triangle causing an imbalance in early and late. The DLL computes a filtered error and adjusts the resampling frequency to correct the error. Residual phase of the on time sample is used to track and remove residual Doppler on the carrier. The residual Doppler values are saved to be used for refined FOA estimation. Timestamps of the

first chip of each symbol are saved to be used for refined TOA estimation. Tracking loop interaction with tuning and resampling is illustrated in FIG. 10.

[0098] The demodulation operations of the de-spreader/demodulator **908** involve: taking the prompt accumulated samples from the tracking loops; making hard bit decisions; and forwarding the demodulated bits to an error correction component. The error correction can be achieved using a BCH decoder according to the parameters applied to the signal. The error correction is performed to correct bit errors. If the message payload is encrypted or is encoded for authentication, the applicable algorithm may be applied on the error corrected samples.

[0099] In some scenarios, all components except for the GEO processor **914** are implemented in software. The present solution is not limited in this regard. Each of the components shown in FIG. 9 can be implemented in hardware, software or a combination thereof.

[00100] Time and Frequency Tagging

[00101] One of the outputs of the chip and error tracking loops **1002** of FIG. 10 may be an array of timestamp samples from each symbol in the message. This set of samples is curve fit to calculate a refined TOA estimation. The frequency offsets provided by the tracking loop are also curve fit to calculate a refined FOA estimation.

[00102] Atmospheric and Dynamics

[00103] A further refinement to the TOA is accomplished by: determining the satellite position; computing the atmospheric and relativistic delay that affected the detected modulated carrier signal during transmission thereof; and applying the atmospheric and relativistic delay to the high accuracy TOA. The output of this process is a further refined TOA (e.g., a TOA with at least a 100 ns measurement accuracy).

[00104] Each of the DASS satellites has a unique group delay which affects the TOA at the ground station. The bias for each satellite is determined using a procedure to compute the group delay offsets. This delay is applied to the TOA prior to Geolocation processing.

[00105] Geolocation Processing

[00106] The output of the de-spreader/demodulator **908** is a packet of error corrected payload data with the corresponding TOA and FOA estimates. For each of the DSSS sub-systems (e.g., sub-systems **114-120** of FIG. 1), these packets will be stored in a server (e.g., sever **112** of FIG. 1). The packets are then associated in the GEO location processing device (e.g., device **160** of FIG. 1) and a solution is calculated.

[00107] Exemplary Methods For Determining A High Accuracy TOA

[00108] A high accuracy TOA is determined during a TOA measurement process. The input to the TOA measurement process is a coarse TOA. In some scenarios, the coarse TOA is determined by: capturing an RF signal at a downconverter; providing an analog down converted RF signal to an A/D converter; providing the digital signal to a sampler; generate a plurality of input samples by sampling the RF spectrum using the digital signal output from the A/D converter; and cross correlating the input samples (on a sample-by-sample basis) with samples of a local copy of a PN code (i.e., a code that represents the signal of interest or a replica of the signal of interest) to identify peaks. In some cases, Doppler effects need to be addressed via an FFT. The term “Doppler effect(s)”, as used herein, refers to the change in frequency of a wave for an observer moving relative to its source. The cross correlation de-spreads the signal, and the FFT specifies where the peak is in frequency.

[00109] It is undesirable to process or further process every potential peak. Accordingly, a threshold is employed that represents a level above which a real detection is made. The thresholding provides a way to discriminate between noise that causes a false signal detection and noise with enough energy to be considered a signal. The thresholding involves determining a threshold crossing by comparing sample energy levels to the threshold. The sample associated with the threshold crossing is noted. The sample count relative to the time of day is known. This time of day represents the coarse TOA. The time resolution of the coarse TOA is not desirable in some scenarios. As such, additional operations are performed to improve the accuracy of the estimated TOA.

[00110] The input to the additional operations is the coarse TOA. The coarse TOA is used to determine which sample should be the first sample in subsequent down conversion operations. The sample associated with the coarse TOA is used as the first sample. All N-1 subsequent samples are also used in the subsequent down conversion operations, where N is an integer number selected to provide the desired resolution for a high accuracy TOA. The frequency of this set of N samples is then down converted to zero Hertz (0 Hz) to remove Doppler effects. The down conversion is done digitally via signal processing. The signal processing involves: multiplying a complex exponential using a frequency bin at which the signal detection was made; and moving the frequency of the detected signal to zero Hertz (0 Hz).

[00111] Thereafter, the signal (or samples) is(are) filtered to recreate the SinX/X shape of the original spread spectrum signal. Techniques for such filtering are well known in the art. Any known or to be known filtering technique for recreating a SinX/X shape of a signal can be used herein without limitation. In some scenarios, the filtering operations are Finite Impulse Response (“FIR”) filtering operations. Exemplary coefficients or taps of the FIR filter are shown in FIG. 12. An exemplary input signal to the filtering operations is shown in the left graph of FIG. 14. An exemplary output signal of the filtering operations is shown in the right graph of FIG. 13.

[00112] Next, the filtered samples are used in a cross correlation process. The cross correlation process involves taking each set of samples that represents one symbol from the local PN code. Each set of samples comprises an oversampled number of chips. Each symbol comprises a certain number chips that represent that symbol. In some cases, two hundred fifty six (256) chips represent a sample. By oversampling by four (4), one thousand twenty four (1024) samples for a window that represents one symbol. The thousand twenty four (1024) samples are cross correlated with the one thousand twenty four (1024) samples to obtain a cross correlation between the filtered samples and the samples of the PN code to obtain a correlation peak. FIG. 14 includes an upper left graph showing an overlay between the detected signal samples and the shifter version of the local PN code. The FIG. 14 also includes a bottom right graph showing the magnitude of the output from the cross correlation process. The correlation

peak is then used to find the peak center of the pulse for each symbol of the detected signal. FIG. 15 includes a graph showing an exemplary peak center of one symbol's correlation.

[00113] Next, symbol estimation is performed. The symbol estimation involves: selecting the two peak values with the highest magnitude; and computing an average value for each symbol to obtain a set of estimated symbols. The set of estimated symbols is then further down converted to remove any remaining frequency offset. The set of estimated symbols are then used to obtain a value representing twice the center frequency. The center frequency is then further down converted to remove any trace of Doppler effects in the detected signal prior to determining the high accuracy TOA.

[00114] Now that all traces of Doppler effects has been removed from the detected signal, a set of detected signal samples are cross correlated with a set of sample from the local PN code in much the same manner as described above. A set of W (e.g., 5) symbols are averaged (point-by-point) so that a better Signal to Noise Ratio ("SNR") measurement can be obtained. As should be understood, the signal is dilated or contracted in proportion to Doppler. Accordingly, W is an integer value selected for improving an SNR in view of the dilatation/contraction phenomenon. For example, the higher the Doppler Effect, the smaller the value of W . The lower the Doppler Effect, the larger the value of W . For each set of W symbols, a parabolic curve fit is performed so that an interpolated subsample frequency offset can be determined. FIG. 19 shows the results of one of the W symbol moving window calculation. These results are used to generate a parabolic curve fit shown in FIG. 20. The parabolic curve fit is used to look for a peak interpolated value of the maximum. FIG. 21 shows a graph plotting the peak interpolated values for each window of five symbols. As evident from FIG. 21, the sample offset increases over time so the signal is dilating (contracting). The TOA at this point is the intercept value computed from the parabolic curve fit. The original coarse TOA is refined with the intercept value. A high accuracy TOA is obtained by dividing the intercept value (i.e., a sample offset of a sample) by a sample rate.

[00115] The above described process is shown schematically in FIG. 11. Referring now to FIG. 11, there is provided a flow diagram of an exemplary method **1100** for determining a high

accuracy TOA. Method **1100** begins with step **1102** and continues with step **1104** where a spread spectrum signal is detected. Once the spread spectrum signal is detected, a coarse TOA is determined by: sampling an RF spectrum; maintaining a sampled copy of a PN code used in the spread spectrum signal; cross correlating the copy of the PN code with the input samples of the RF spectrum; performing an FFT on the output of the correlation to find a correlation peak (presence of the spread spectrum signal); and determining an energy threshold above which further process will occur. If the energy exceeds the threshold, then a note of the specific sample offset and frequency bin where the threshold crossing occurs is made. The sample offset and frequency bin are then used to determine the coarse TOA. Once the coarse TOA is determined, the high accuracy TOA measurement process begins.

[00116] The high accuracy TOA measurement process is described in relation to steps **1106-1128**. These steps involve: down converting the spread spectrum signal to 0 Hz to remove Doppler by (a) using a set of samples that contain a length of the transmitted spread spectrum signal starting from the threshold crossing and the frequency bin and (b) multiplying the samples by the complex exponential; and filtering the spread spectrum signal using the down converted set of samples that contain a length of the transmitted spread spectrum signal. The filtering involves smoothing the spread spectrum signal to match that of the DSSS signal. In some scenarios, the filter length is seven (7), i.e., not quite two (2) chips at a sampling rate (“fs”) equal to four (4) samples per chip.

[00117] Upon completing step **1108**, method **1100** continues with steps **1110-1114**. These steps involve using the filtered samples to: extract a set of samples of the local PN code that contain symbol k ; cross correlate the set of local PN samples with the signal across a window; and repeating the extracting and cross correlating for symbol $k+1$. In some scenarios, the window is $\pm N$ samples (e.g., 9 samples) from the threshold crossing. A symbol comprises 256 chips times 4 samples per chip (i.e., 1024 bits). The present solution is not limited to the particulars of this example. Each symbol’s correlation yields a peak pulse. Therefore, in a next step **1116**, the center of the peak pulse for each symbol is determined using the outputs of the cross correlation operations. FIG. 15 shows an exemplary peak center of a symbol’s correlation.

[00118] In a next step 1118, the two best peak values are found using the correlation windows for each sample. The two largest peak values are then weighted in step 1120 by a scale factor. The scaled peak values are then added together to establish the symbol magnitude and phase.

[00119] When step 1120 is completed, step 1122 is performed. In step 1122, a frequency estimation is determined using established symbols. The established symbols are used to: estimate a refined center frequency; and find an interpolated peak. The refined center peak is estimated using an FFT across the first M symbols. In some scenarios, M equals one hundred twenty eight (128). In this case, an estimated refined center frequency is defined by the following mathematical equations.

```
xd = symbols(1:128) * symbols(1:128)
faxis = 0.5*(CHIP_RATE/CHIPS_PER_SYMBOL)*[-64:63]/128
X = FFTshift(abs(FFT(xd)))
```

where X represents an estimated refined center frequency. The interpolated peak is found using a curve fitting technique. The curve fitting technique involves curve fitting a peak. A derivative of the curve fit equals zero (0) to find an FOA. FIG. 18 shows an exemplary FOA derived from the results of the curve fitting technique. Using the FOA, the signal is down converted to 0 Hz. The signal FOA is an FOA from a detector plus the refined FOA.

[00120] Thereafter, the windowed symbol correlations are repeated in step 1124 to gather new symbol correlation windows. The new symbol correlation windows are then used in step 1126 to integrate the correlation windows from and find that interpolated peak value over a window of K symbols (e.g., 5 symbols). Next, the process involves stepping by one symbol and integrating the next set of K symbols. FIG. 19 comprises a schematic illustration that is useful for understanding how a set of K symbols is integrated. FIG. 20 provides a graph showing integrated peak values over K symbols. FIG. 21 comprises a graph showing integrated correlation peak values over K symbols.

[00121] In a next step 1128, a TOA estimation is determined. The TOA estimation is determined by: using the interpolated peak values for each of the K symbols moving average to

plot sample (time offset) at peak values versus symbol number; and curve fitting the symbols versus sample offset. The curve fit is a function that defines the sample offset as it varies over time. The intercept value ($x=0$) is the function of a sample from the threshold crossing that the signal is detected. FIG. 22 comprises a graph showing a curve fit of symbol peak sample offsets. FIG. 23 comprises graphs that are useful for understanding time dilation/contraction.

[00122] Referring now to FIG. 24, there is provided a flow diagram of an exemplary method **2400** for determining a high accuracy TOA. Method **2400** begins with step **2402** and continues with step **2404** where a coarse TOA and a coarse FOA are determined, through signal detection, for a sample of the original information-bearing signal. In a next step **2406**, a multi-stage down conversion process is performed using at least the samples associated with the coarse FOA at the point of detection to remove a Doppler effect from the original information-bearing signal. Then in step **2408**, a first set of samples from the original information-bearing signal are cross correlated to a second set of samples from a local copy of the PN code sequence to determine a cross correlation peak. The cross correlation peak is used in step **2410** to find a first temporal peak center for a pulse for each symbol of the original information-bearing signal. The correlation peak is used in step **2412** to find a first temporal peak center for each symbol of the original information-bearing signal. The first temporal peak center is used in step **2414** to obtain a set of first estimated symbols. The set of first estimated symbols is used in step **2416** to obtain a value representing twice a center frequency. The first set of samples is down converted in step **2418** using the center frequency to remove any remaining trace of Doppler effect from the original information-bearing signal. Thereafter, step **2420** is performed where method **2400** ends or other processing is performed.

[00123] Referring now to FIG. 25, there is provided a flow diagram of an exemplary method **2500** for understanding a high resolution TOA process. The high resolution TOA process may be performed after completion of method **2400** discussed above.

[00124] Method **2500** begins with step **2502** and continues with step **2504** where a correlation peak is obtained by cross correlating a first set of samples obtained from the original information-bearing signal with the removed Doppler effect to a second set of samples obtained

from the local copy of the PN code sequence. Next in step **2506**, a second temporal peak center is used to obtain a set of estimated symbols. A curve fit (e.g. linear) is then generated in step **2508** using the set of estimated symbols. The high accuracy TOA is determined in step **2510** by dividing an intercept value of a sample-by-sample rate. The intercept value is obtained using the curve fit and the samples associated with the coarse TOA. Subsequently, step **2512** is performed where method **2500** ends or other processing is performed.

[00125] All of the apparatus, methods, and algorithms disclosed and claimed herein can be made and executed without undue experimentation in light of the present disclosure. While the invention has been described in terms of preferred embodiments, it will be apparent to those having ordinary skill in the art that variations may be applied to the apparatus, methods and sequence of steps of the method without departing from the concept, spirit and scope of the invention. More specifically, it will be apparent that certain components may be added to, combined with, or substituted for the components described herein while the same or similar results would be achieved. All such similar substitutes and modifications apparent to those having ordinary skill in the art are deemed to be within the spirit, scope and concept of the invention as defined.

[00126] The features and functions disclosed above, as well as alternatives, may be combined into many other different systems or applications. Various presently unforeseen or unanticipated alternatives, modifications, variations or improvements may be made by those skilled in the art, each of which is also intended to be encompassed by the disclosed embodiments.

CLAIMS

We claim:

1. A method for determining an accurate location of a signal's source of transmission, comprising:

demodulating, by a receiver of a communication device, a detected carrier signal modulated with a Pseudo Noise ("PN") code sequence to obtain an original information-bearing signal therefrom;

computing, by the receiver, time delay offsets using correlations of PN code windows for each symbol of the original information-bearing signal;

determining, by the receiver, a high accuracy Time Of Arrival ("TOA") of the detected carrier signal using the time delay offsets; and

using, by the receiver, the high accuracy TOA to determine an accurate location of the original information-bearing signal's source of transmission.

2. The method according to claim 1, wherein the demodulating comprises:

detecting a phase deviation from the detected carrier signal;

removing the phase deviation from the detected carrier signal;

performing early/late gate tracking to recover symbol timing phase of the detected carrier signal; and

performing demodulation of the detected carrier signal using the recovered symbol timing thereof to extract the original information-bearing signal therefrom.

3. The method according to claim 1, further comprising:

curve fitting the time delay offsets to construct a fitted curve that has a best fit to a series of data points defining the time delay offsets; and

extrapolating unknown time delay offsets using the fitted curve.

4. The method according to claim 3, wherein the high accuracy TOA is determined using the unknown time delay offsets that were extrapolated using the fitted curve.

5. The method according to claim 1, further comprising refining the high accuracy TOA by:
 - determining a satellite position;
 - computing an atmospheric and relativistic delay that effected the detected carrier signal during transmission thereof using the satellite position; and
 - applying the atmospheric and relativistic delay to the high accuracy TOA so as to generate a refined TOA.

6. The method according to claim 1, further comprising using the refined TOA to determine an accurate location of the original information-bearing signal's source.

7. The method according to claim 1, wherein the high accuracy TOA is determined by:
 - determining through signal detection, a coarse TOA and a coarse Frequency Of Arrival ("FOA") for a sample of the original information-bearing signal;
 - performing a multi-stage down conversion process using at least samples associated with the coarse FOA at a point of detection to remove a Doppler effect from the original information-bearing signal;
 - cross correlating a first set of samples from the original information-bearing signal with the removed Doppler effect to a second set of samples from a local copy of the PN code sequence to determine a cross correlation peak;
 - using the cross correlation peak to find a first temporal peak center for a pulse for each symbol of the original information-bearing signal;
 - using the cross correlation peak to find a first temporal peak center for a pulse for each symbol of the original information-bearing signal;
 - using the first temporal peak center to obtain a set of first estimated symbols;
 - using the set of first estimated symbols to obtain a value representing twice a center frequency; and

down converting the first set of sample using the center frequency to remove any remaining trace of Doppler effect from the original information-bearing signal.

8. The method according to claim 7, wherein a high resolution TOA process comprises:
 - obtaining a correlation peak by cross correlating a third set of samples obtained from the original information-bearing signal with a removed Doppler effect to a fourth set of samples obtained from the local copy of the PN code sequence;
 - using the second temporal peak center to obtain a set of second estimated symbols;
 - generating a curve fit using the set of second estimated symbols; and
 - determining the high accuracy TOA by dividing an intercept value of a sample-by-sample rate, where the intercept value is obtained using the curve fit and samples associated with the coarse TOA.

9. A method for determining a high accuracy Time Of Arrival (“TOA”), comprising:
 - determining a coarse TOA and a coarse FOA for a sample of an original information-bearing signal received at a receiver of a communication device;
 - performing a multi-stage down conversion process using at least samples associated with the coarse FOA at a point of detection to remove a Doppler effect from the original information-bearing signal;
 - cross correlating a first set of samples from the original information-bearing signal with the removed Doppler effect to a second set of samples from a local copy of a Pseudo Noise (“PN”) code to determine a cross correlation peak, where the PN code represents a signal of interest;
 - using the cross correlation peak to find a first temporal peak center for a pulse for each symbol of the original information-bearing signal;
 - using the cross correlation peak to find a first temporal peak center for a pulse for each symbol of the original information-bearing signal;
 - using the first temporal peak center to obtain a set of first estimated symbols;

using the set of first estimated symbols to obtain a value representing twice a center frequency; and

down converting the first set of samples using the center frequency to remove any remaining trace of Doppler effect from the original information-bearing signal.

10. The method according to claim 9, wherein a high resolution TOA process comprises:

obtaining a correlation peak by cross correlating a third set of samples obtained from the original information-bearing signal with removed Doppler effect to a fourth set of samples obtained from the local copy of the PN code;

using the second temporal peak center to obtain a set of second estimated symbols;

generating a curve fit using the set of second estimated symbols; and

determining the high accuracy TOA by dividing an intercept value of a sample-by-sample rate, where the intercept value is obtained using the curve fit and samples associates with the coarse TOA.

11. A system, comprising:

a receiver comprising an electronic circuit configured to:

demodulate a detected carrier signal modulated with a Pseudo Noise ("PN") code to obtain an original information-bearing signal therefrom;

compute time delay offsets using correlations of PN code windows for each symbol of the original information-bearing signal;

determine a high accuracy Time Of Arrival ("TOA") of the detected carrier signal using the time delay offsets; and

use the high accuracy TOA to determine an accurate location of the original information-bearing signal's source of transmission.

12. The system according to claim 11, wherein the demodulating comprises:

detecting a phase deviation from the detected carrier signal;

removing the phase deviation from the detected carrier signal;

performing early/late gate tracking to recover symbol timing phase of the detected carrier signal; and

performing demodulation of the detected carrier signal using the recovered symbol timing thereof to extract the original information-bearing signal therefrom.

13. The system according to claim 11, wherein the electronic circuit is further configured to:
curve fit the time delay offsets to construct a fitted curve that has a best fit to a series of data points defining the time delay offsets; and
extrapolate unknown time delay offsets using the fitted curve.

14. The system according to claim 13, wherein the high accuracy TOA is determined using the unknown time delay offsets that were extrapolated using the fitted curve.

15. The system according to claim 11, wherein the high accuracy TOA is refined by:
determining a satellite position;
computing an atmospheric and relativistic delay that effected the detected carrier signal during transmission thereof using the satellite position; and
applying the atmospheric and relativistic delay to the high accuracy TOA so as to generate a refined TOA.

16. The system according to claim 11, wherein the refined TOA is used to determine an accurate location of the original information-bearing signal's source.

17. The system according to claim 11, wherein the high accuracy TOA is determined by:
determining, through signal detection, a coarse TOA and a coarse Frequency of Arrival ("FOA") for a sample of the original information-bearing signal;
performing a multi-stage down conversion process using at least samples associated with the coarse FOA at a point of detection to remove a Doppler effect from the original information-bearing signal;

cross correlating a first set of samples from the original information-bearing signal with the removed Doppler effect to a second set of samples from a local copy of the PN code sequence to determine a cross correlation peak;

using the cross correlation peak to find a first temporal peak center for a pulse for each symbol of the original information-bearing signal;

using the cross correlation peak to find a first temporal peak center for a pulse for each symbol of the original information-bearing signal;

using the first temporal peak center to obtain a first estimated symbols;

using the set of first estimated symbols to obtain a value representing twice a center frequency; and

down converting the first set of samples using the center frequency to remove any remaining Doppler effect from the original information-bearing signal

18. The system according to claim 17, wherein a high resolution TOA process comprises:

obtaining a correlation peak by cross correlating a third set of samples obtained from the original information-bearing signal with removed Doppler effect to a fourth set of samples obtained from the local copy of the PN code sequence;

using the second temporal peak center to obtain a set of second estimated symbols;

generating a curve fit using the set of second estimated symbols; and

determining the high accuracy TOA by dividing an intercept value of a sample-by-sample rate, where the intercept value is obtained using the curve fit and samples associated with the coarse TOA.

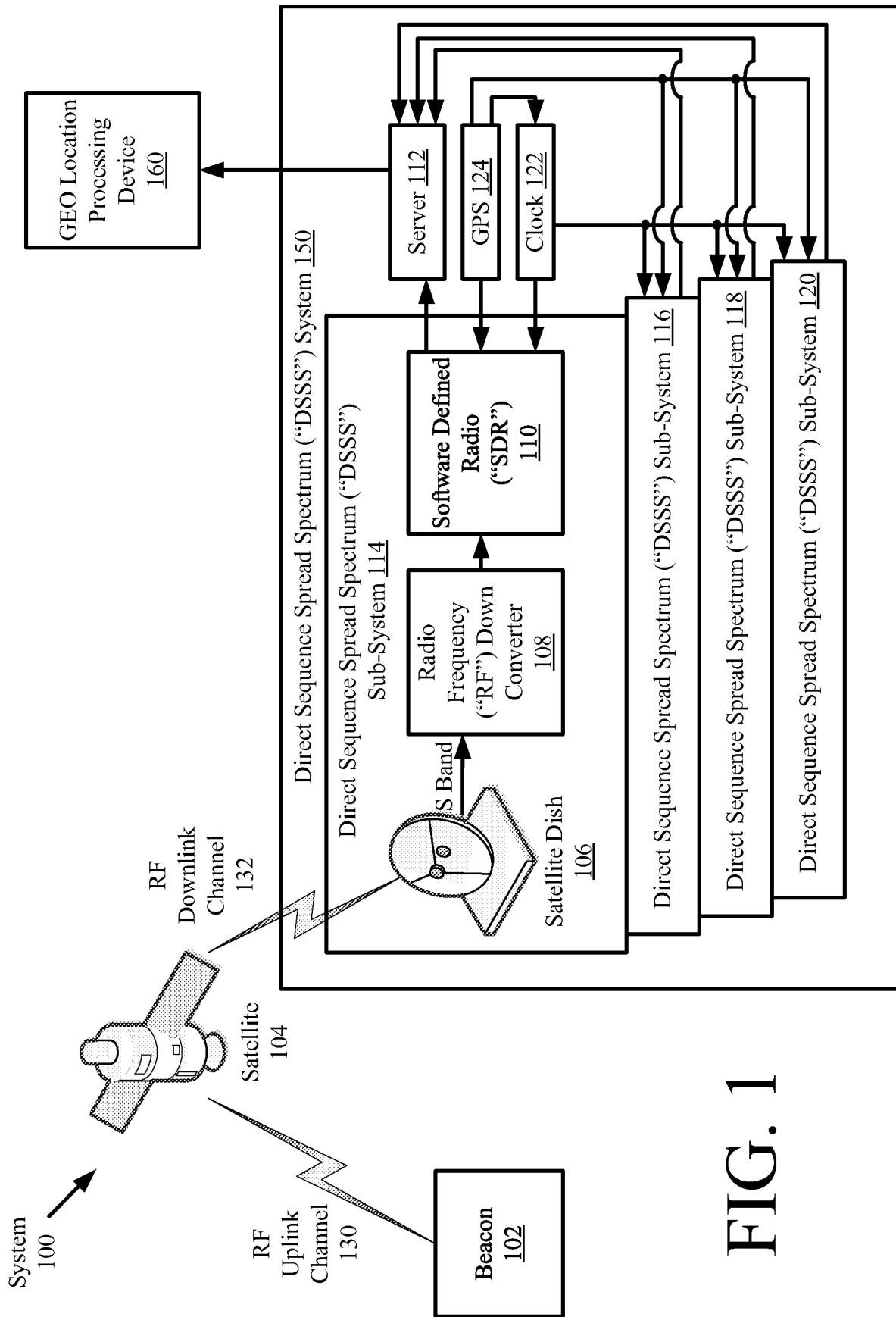

FIG. 1

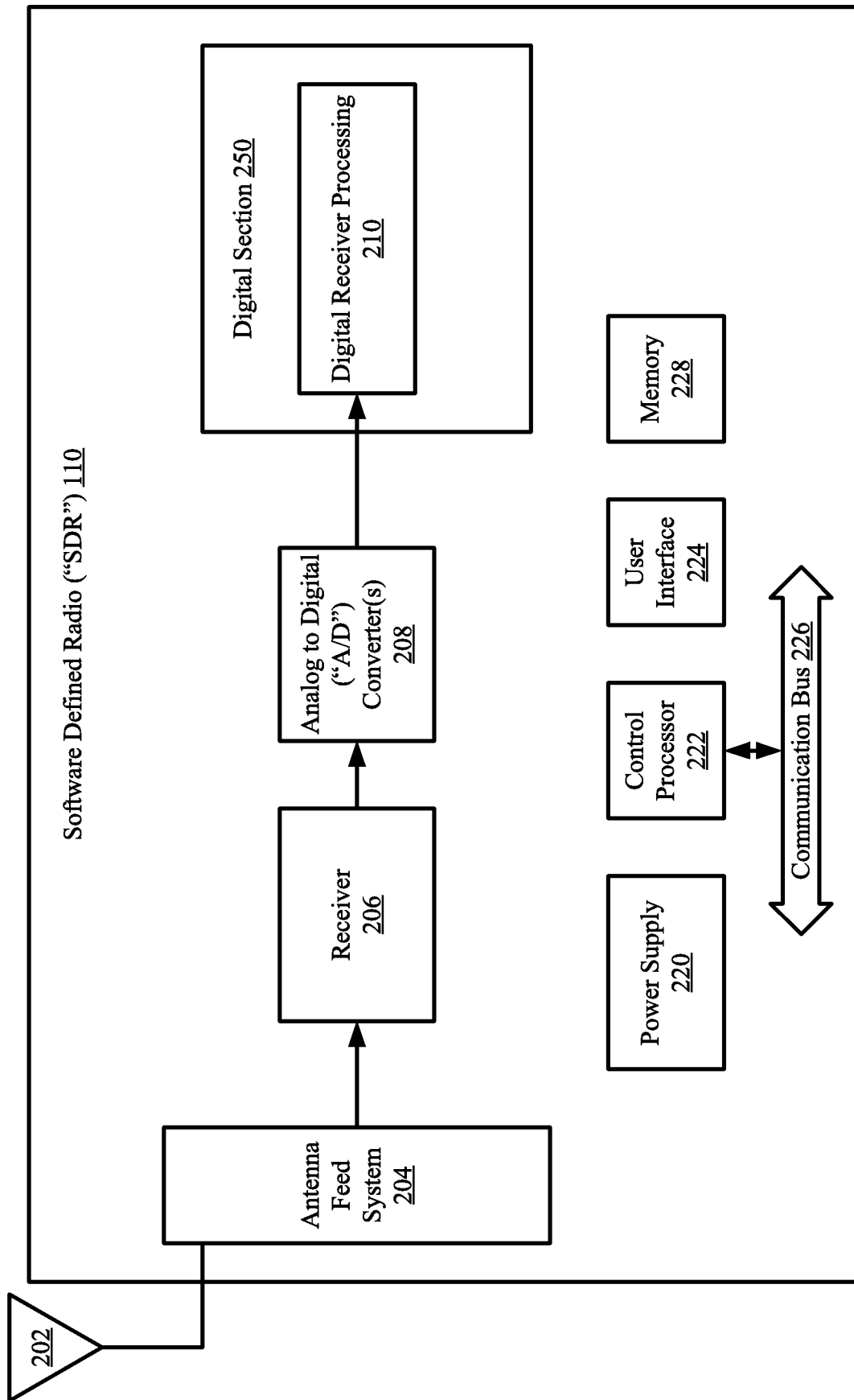

FIG. 2

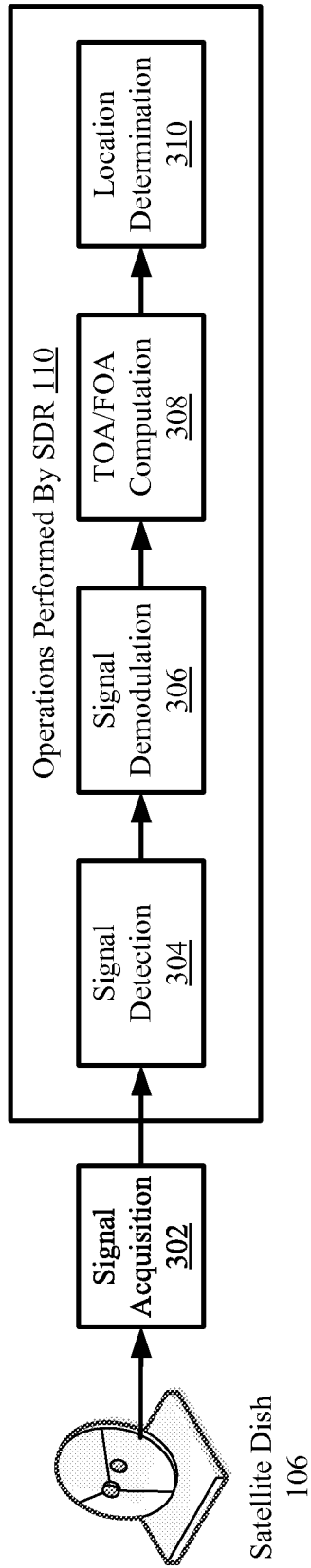

FIG. 3

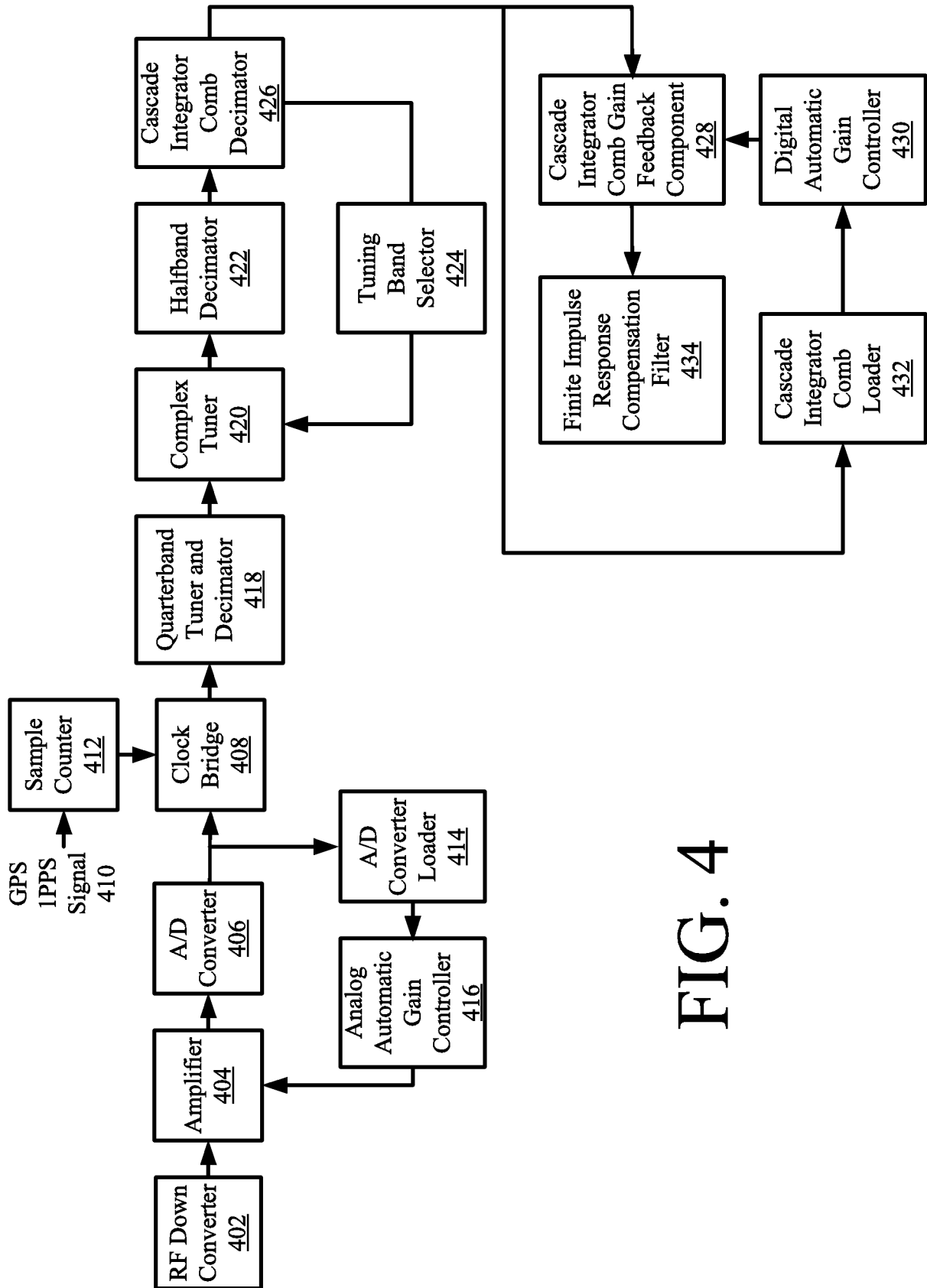

FIG. 4

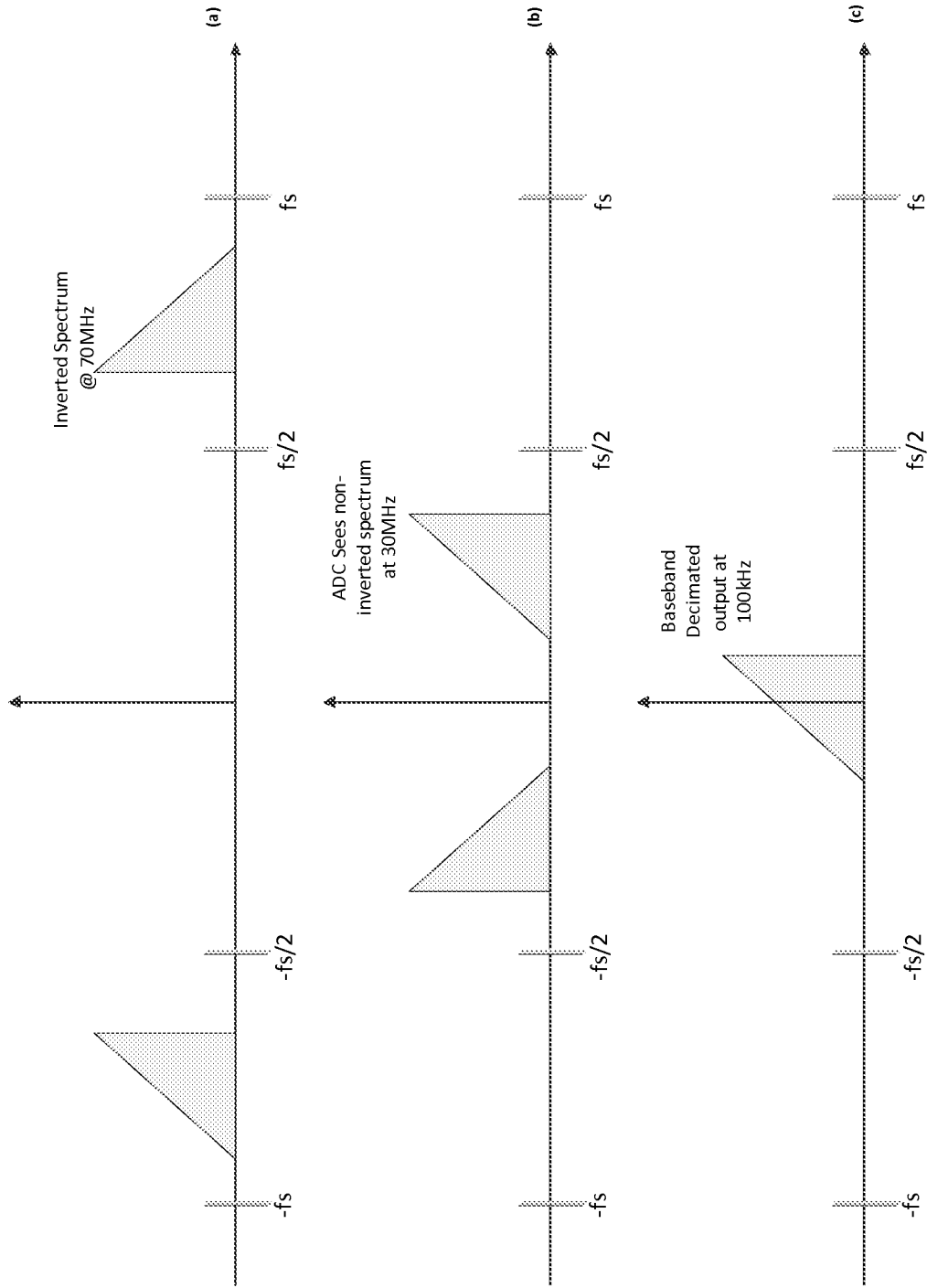

FIG. 5

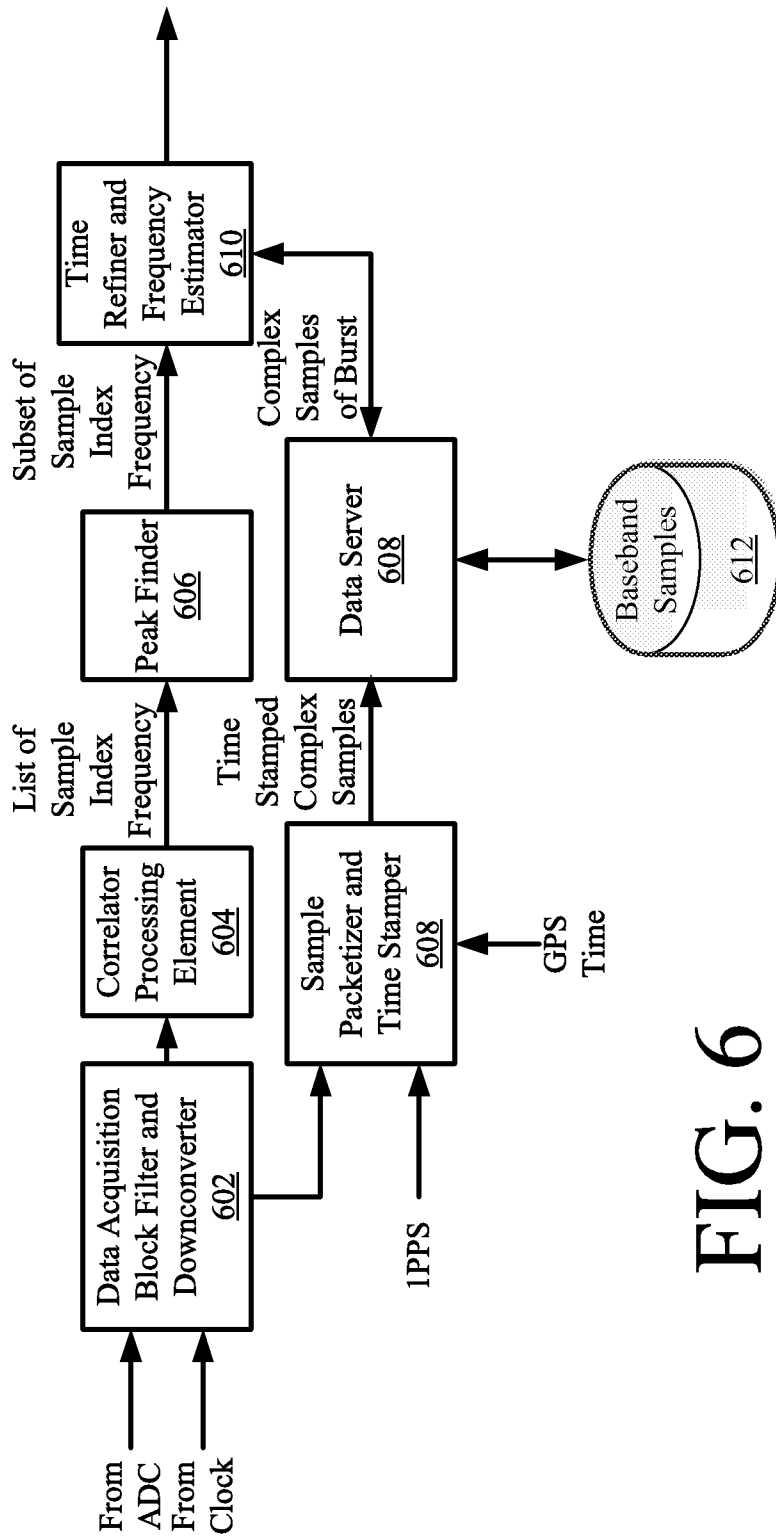

FIG. 6

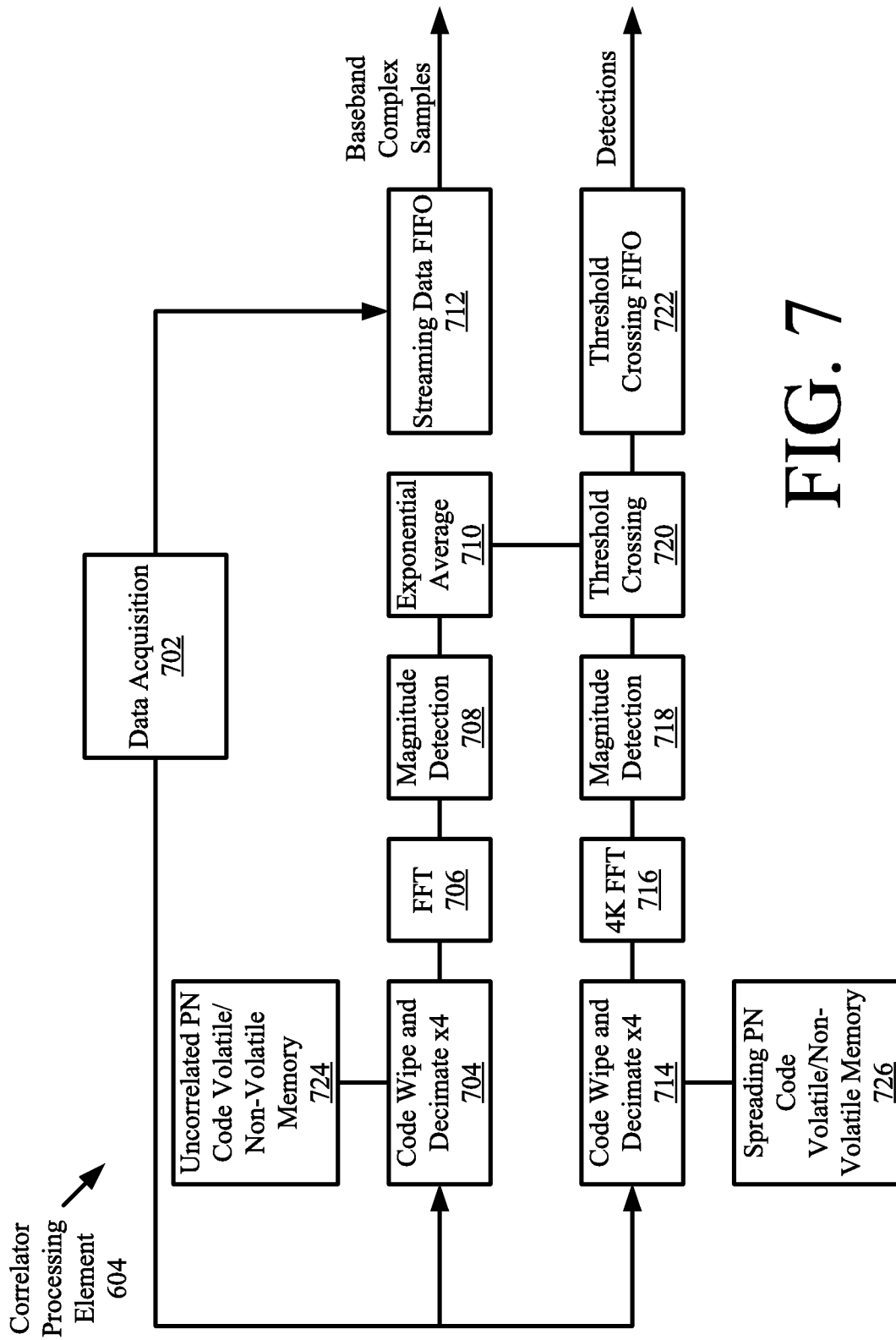

FIG. 7

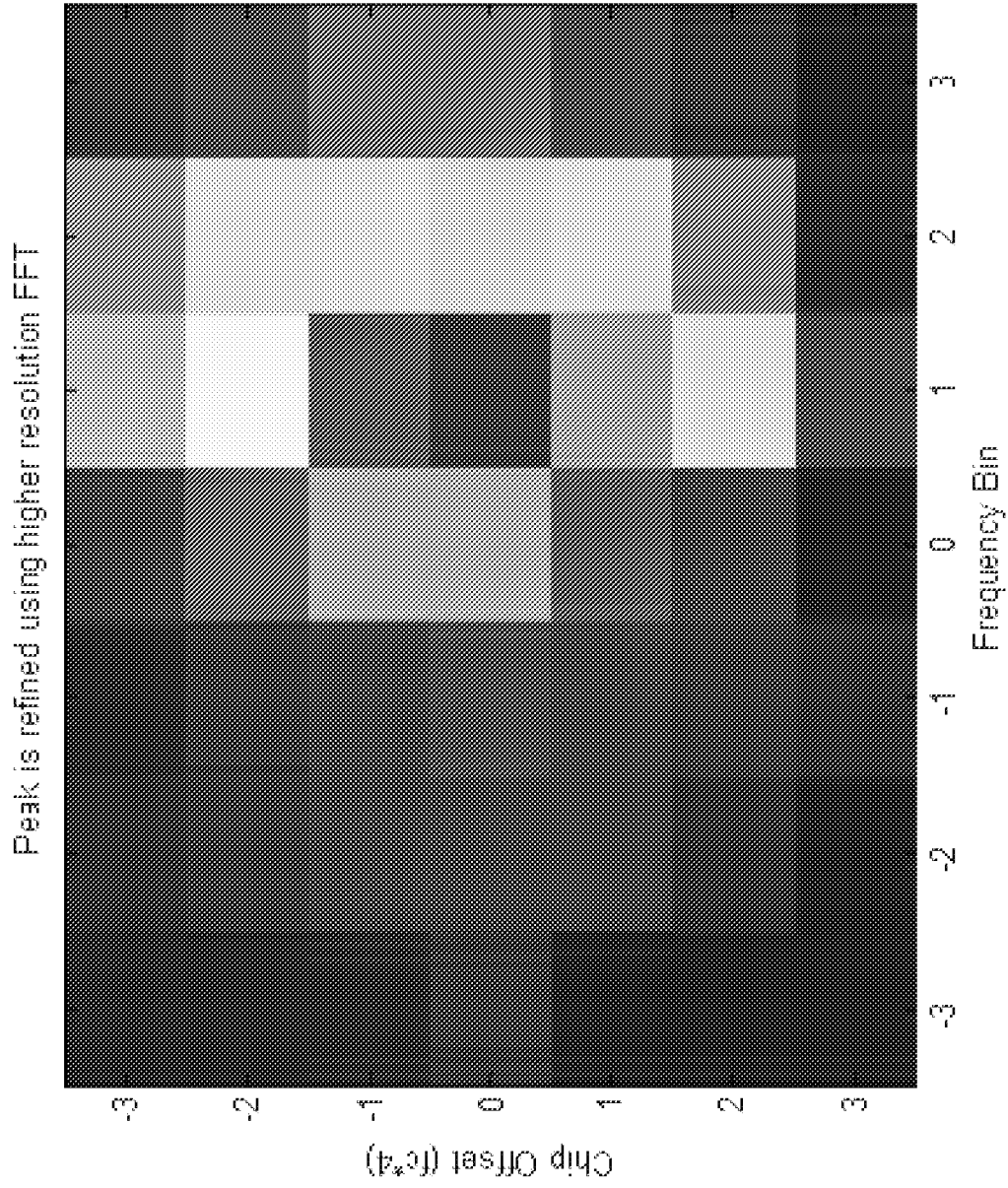

FIG. 8

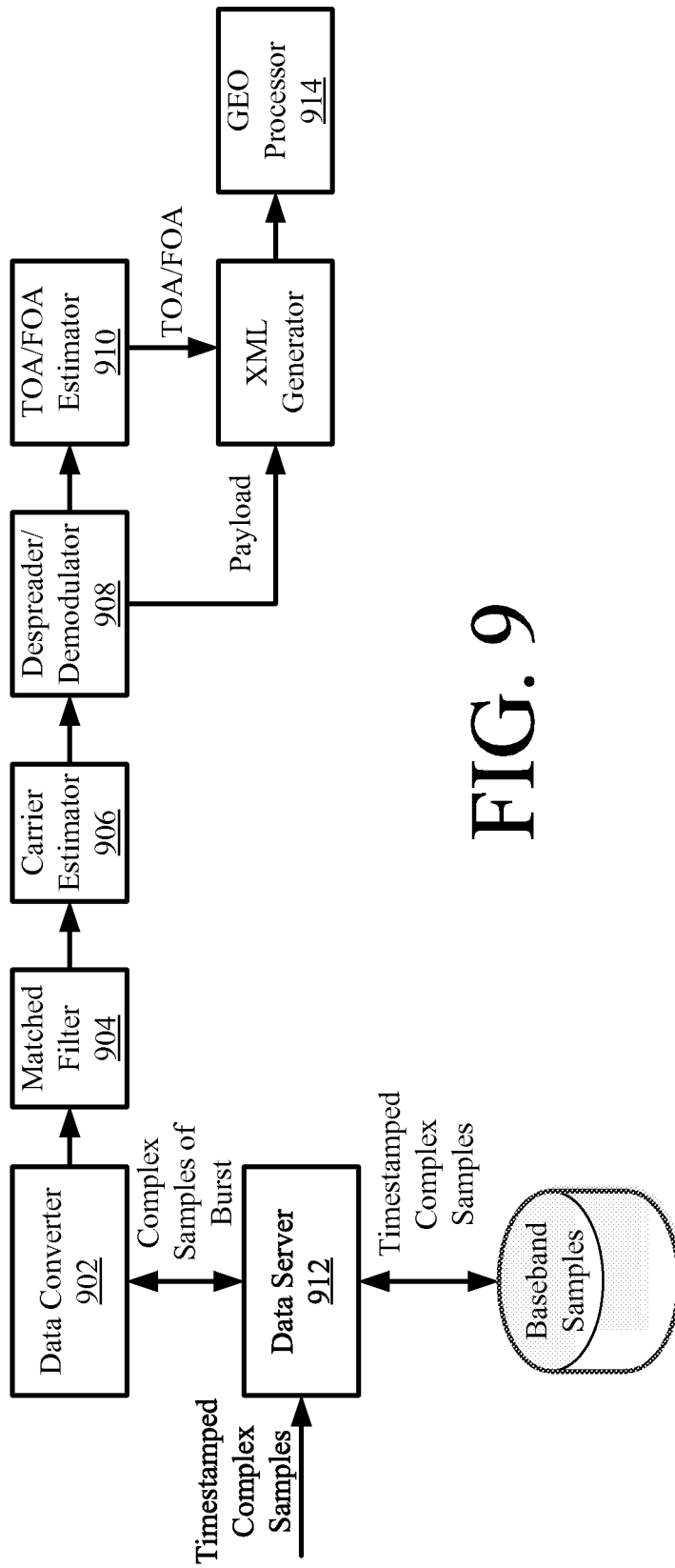

FIG. 9

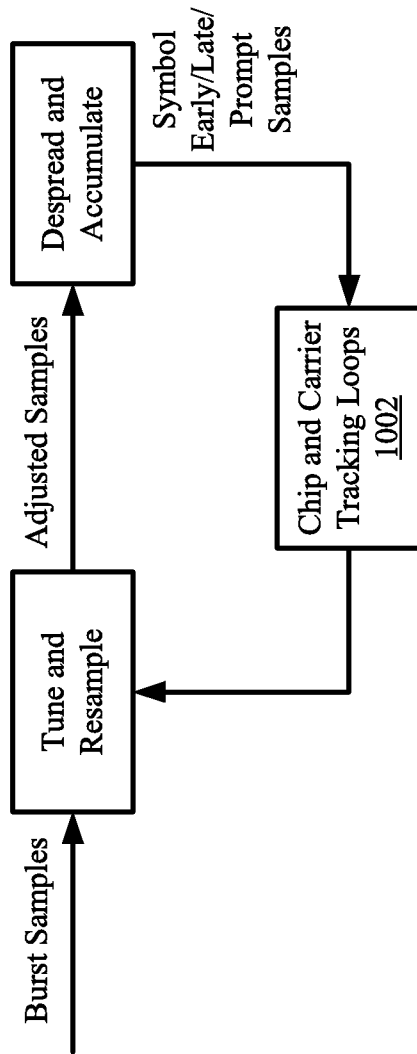

FIG. 10

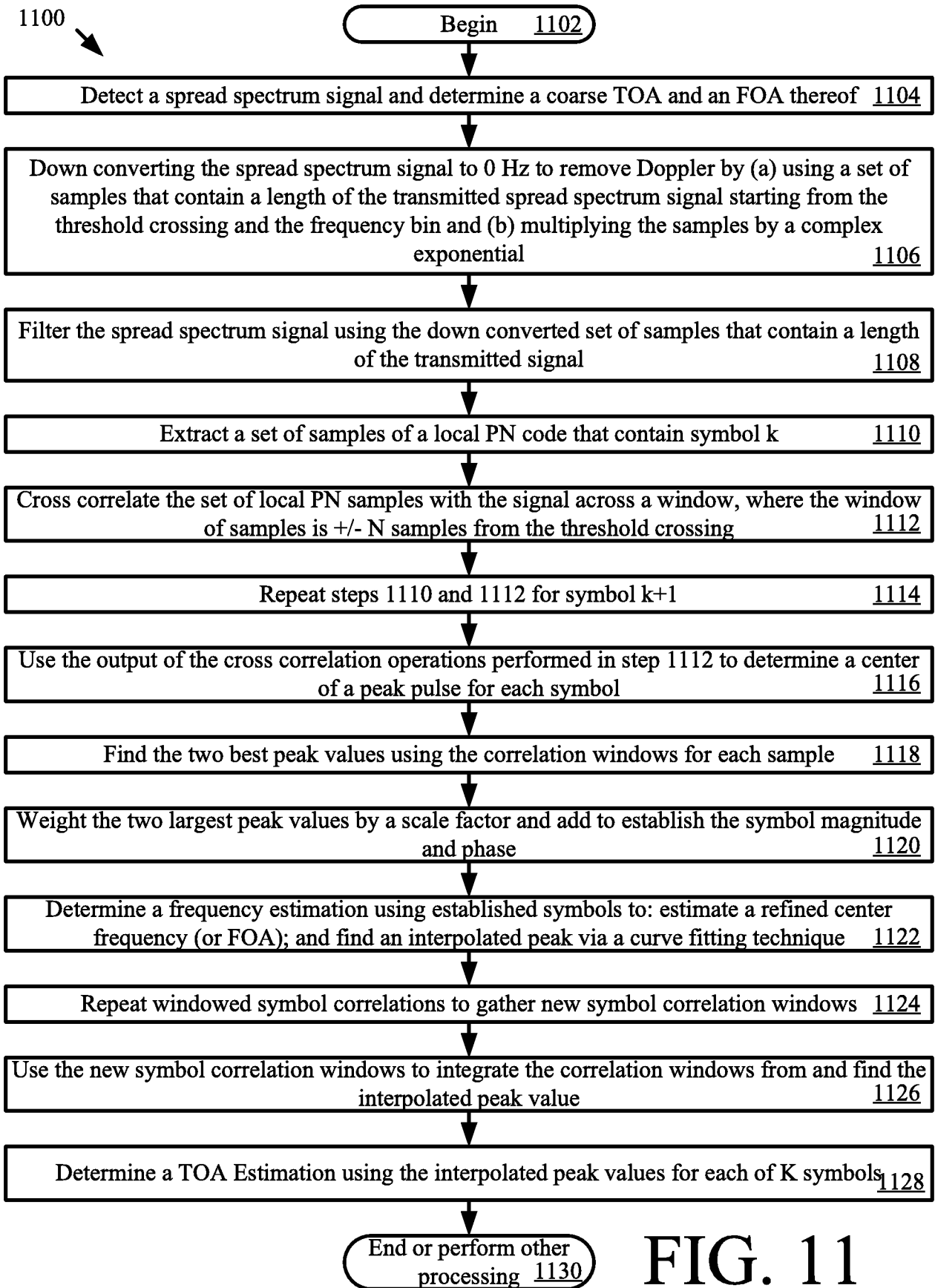

FIG. 11

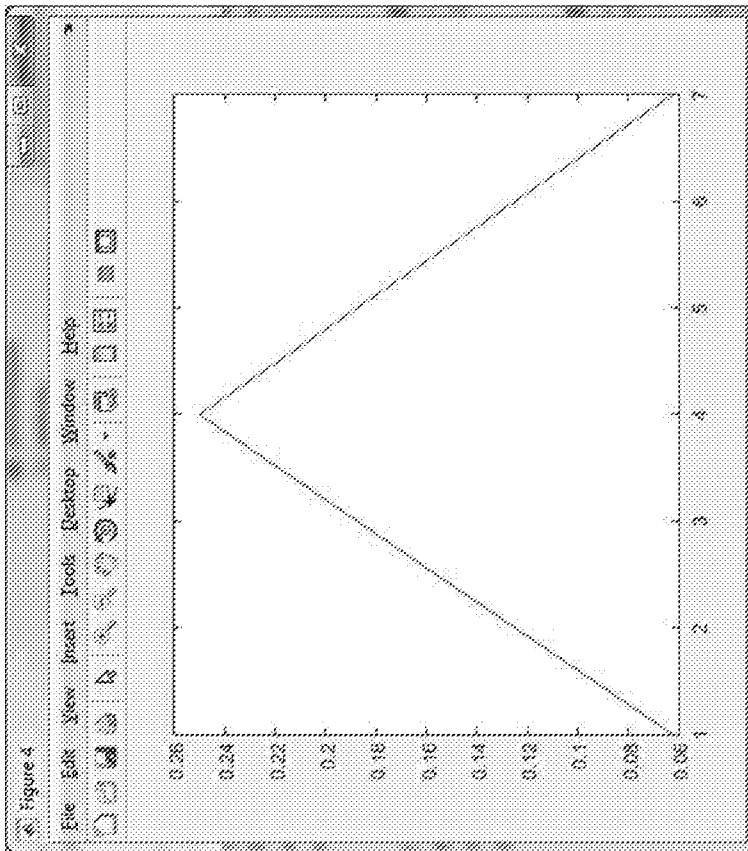
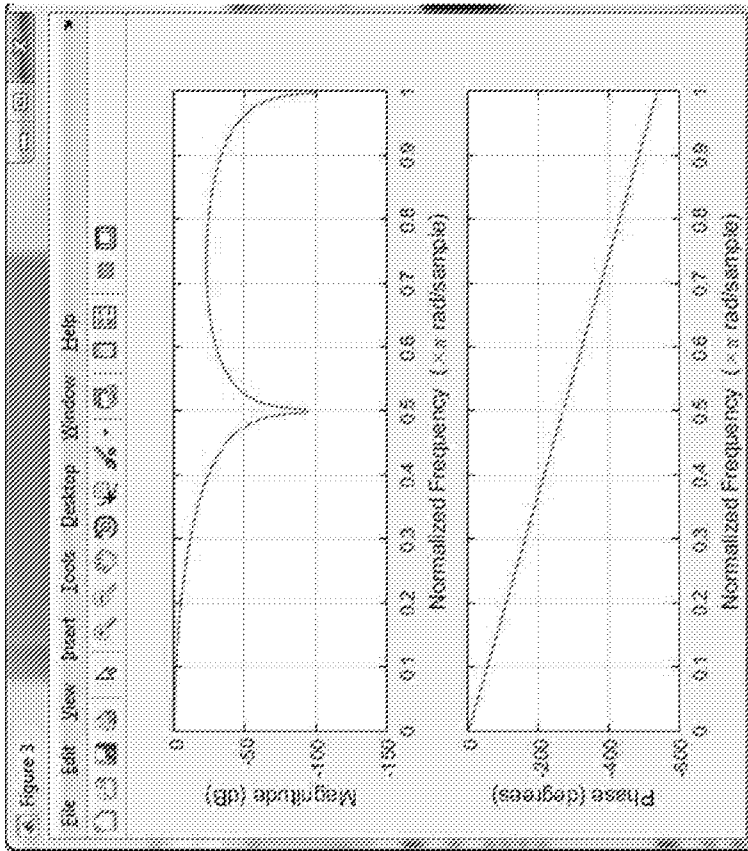
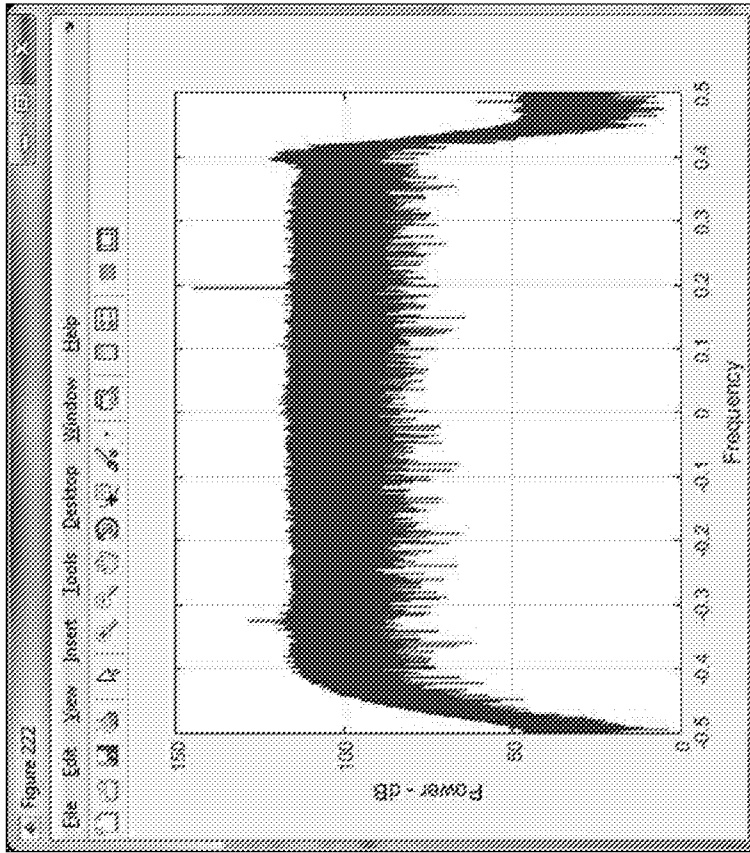

FIG. 12

Input Signal

Input



Filtered

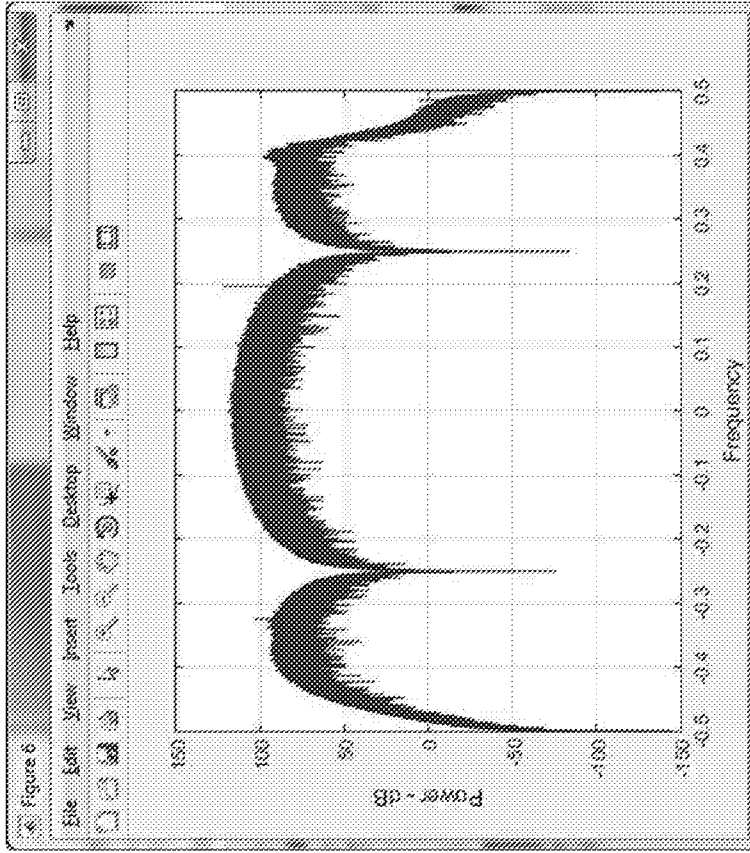
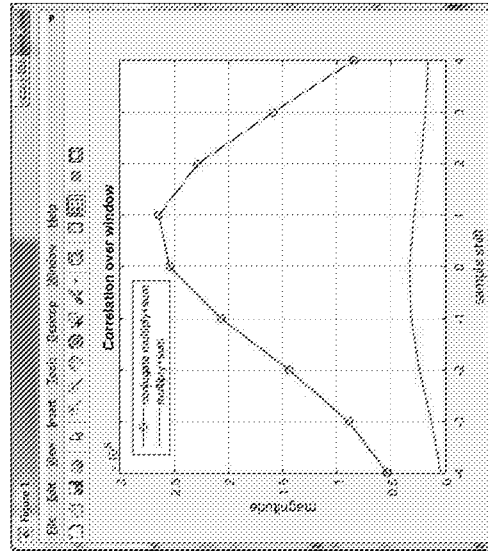
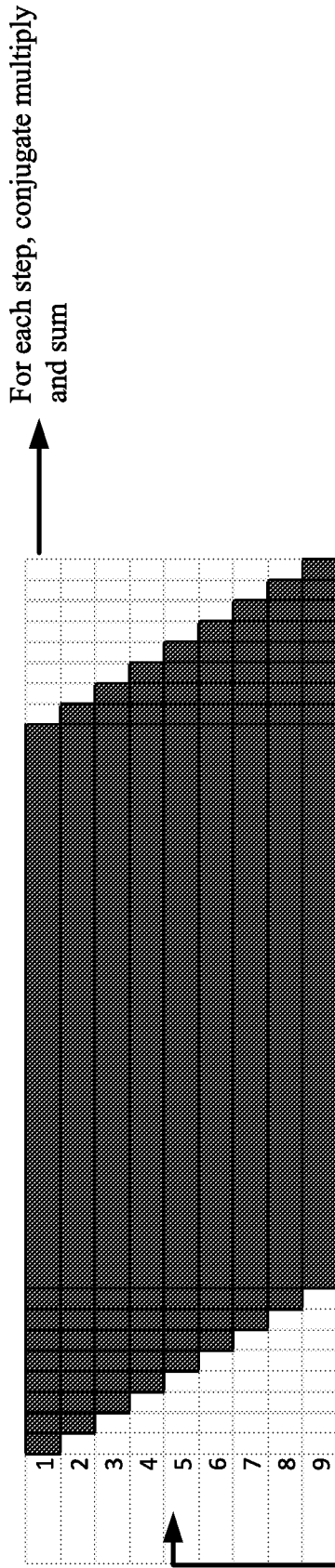

FIG. 13

Cross Correlation: Shift Window of 256 chips from PN Code across 256+9 Input Samples



The output is a complex vector, but figure right is the magnitude.

FIG. 14

One Symbol Correlation Over 9
Sample Window

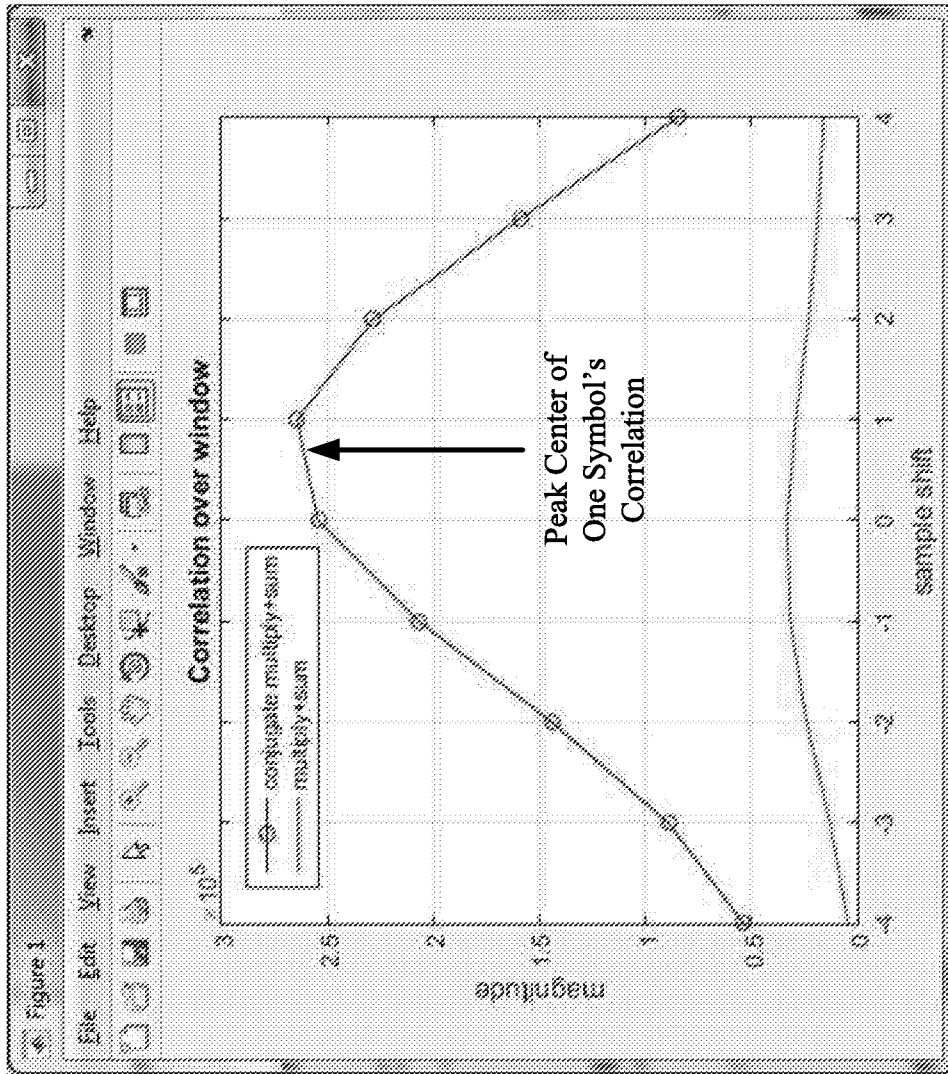

Magnitude
View

FIG. 15

Scale Factor

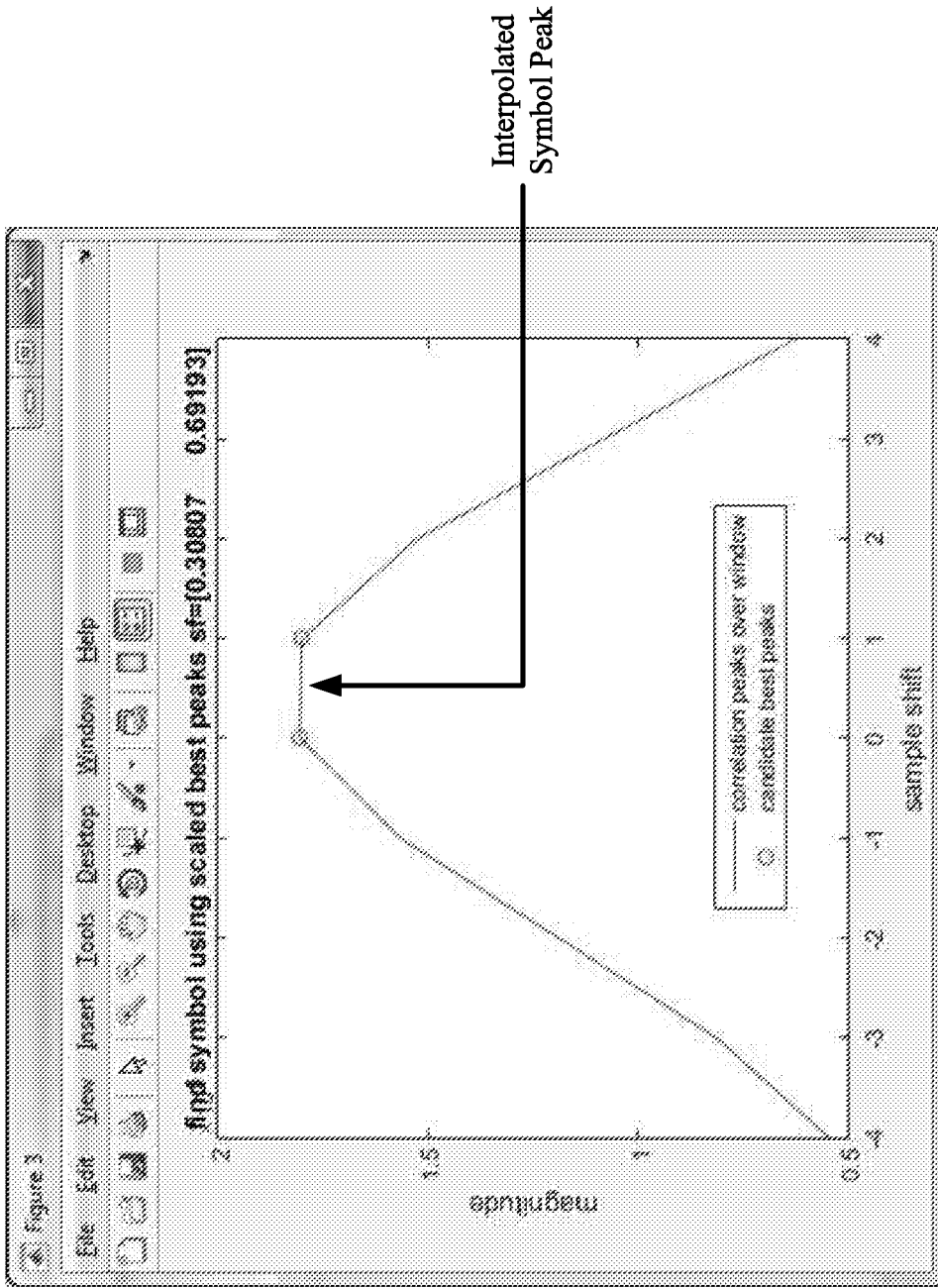

Scale = pt1 * distP2

FIG. 16

Symbol Scaled

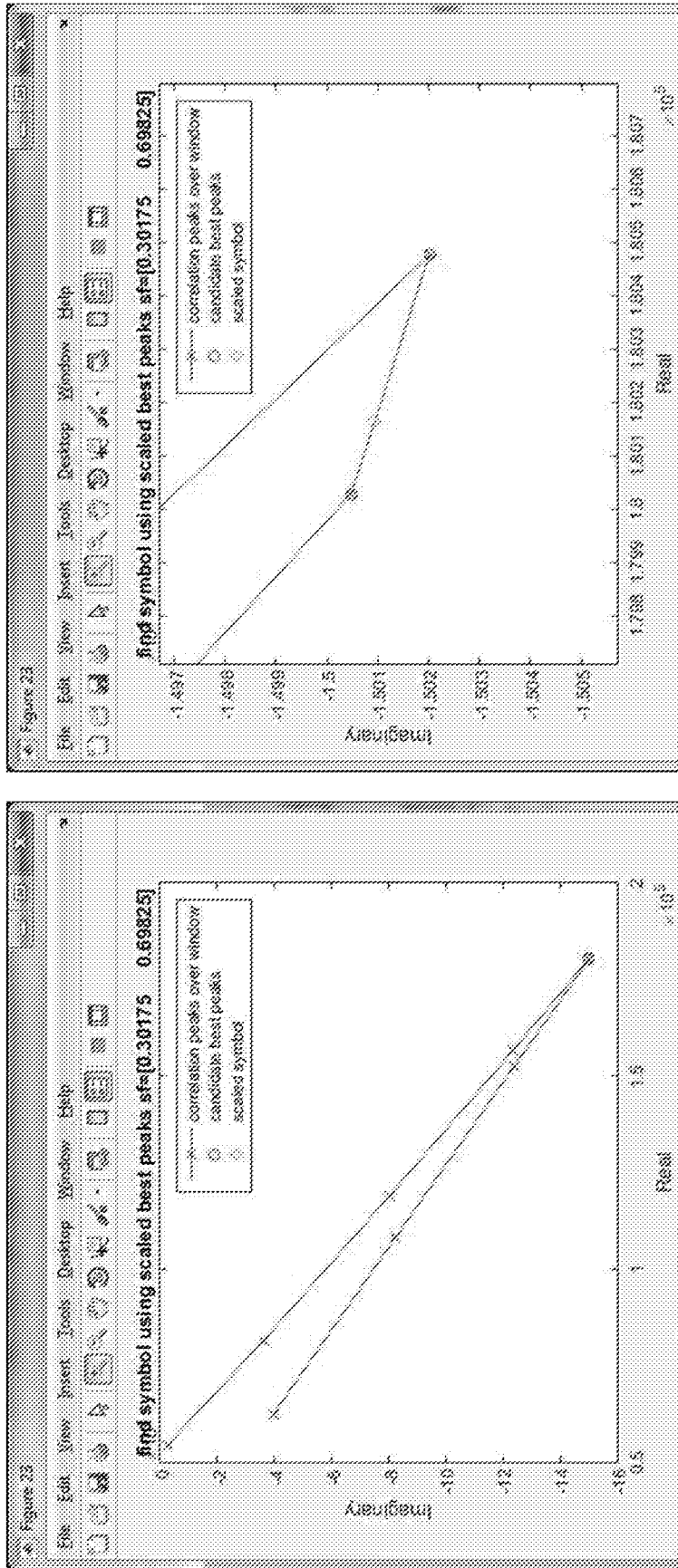

FIG. 17

Frequency Derived From Magnitude Of The Product Of The Symbols x Symbols

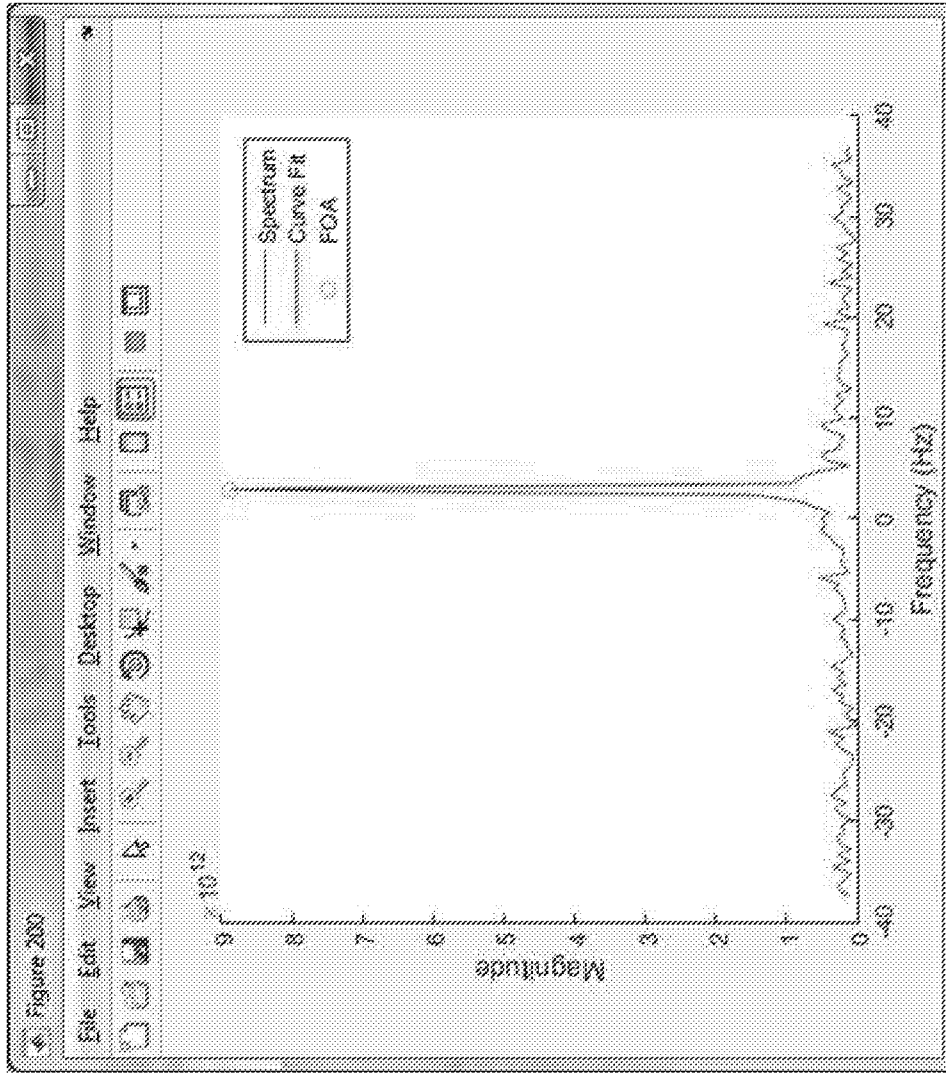
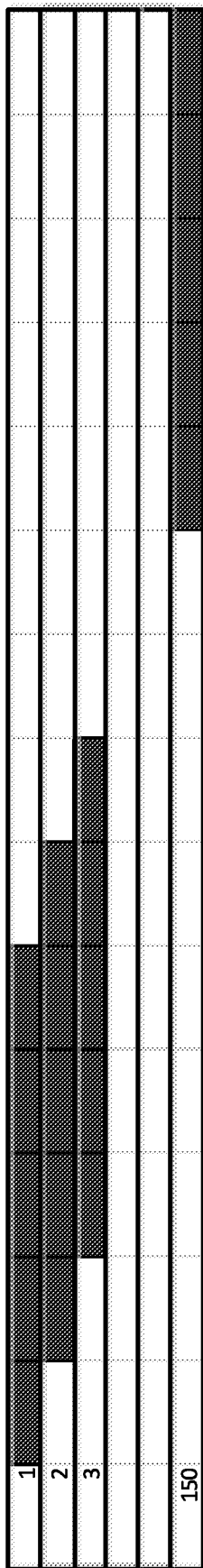

FIG. 18

Integrate Window of K Symbols (e.g., 5 Symbols)



Each blue box is a set of 9 correlation peak values for a single symbol. For each step, sum the correlation peak values for 5 symbols.

FIG. 19

Integrated Correlation Peak Values Over K (e.g., 5) Symbols

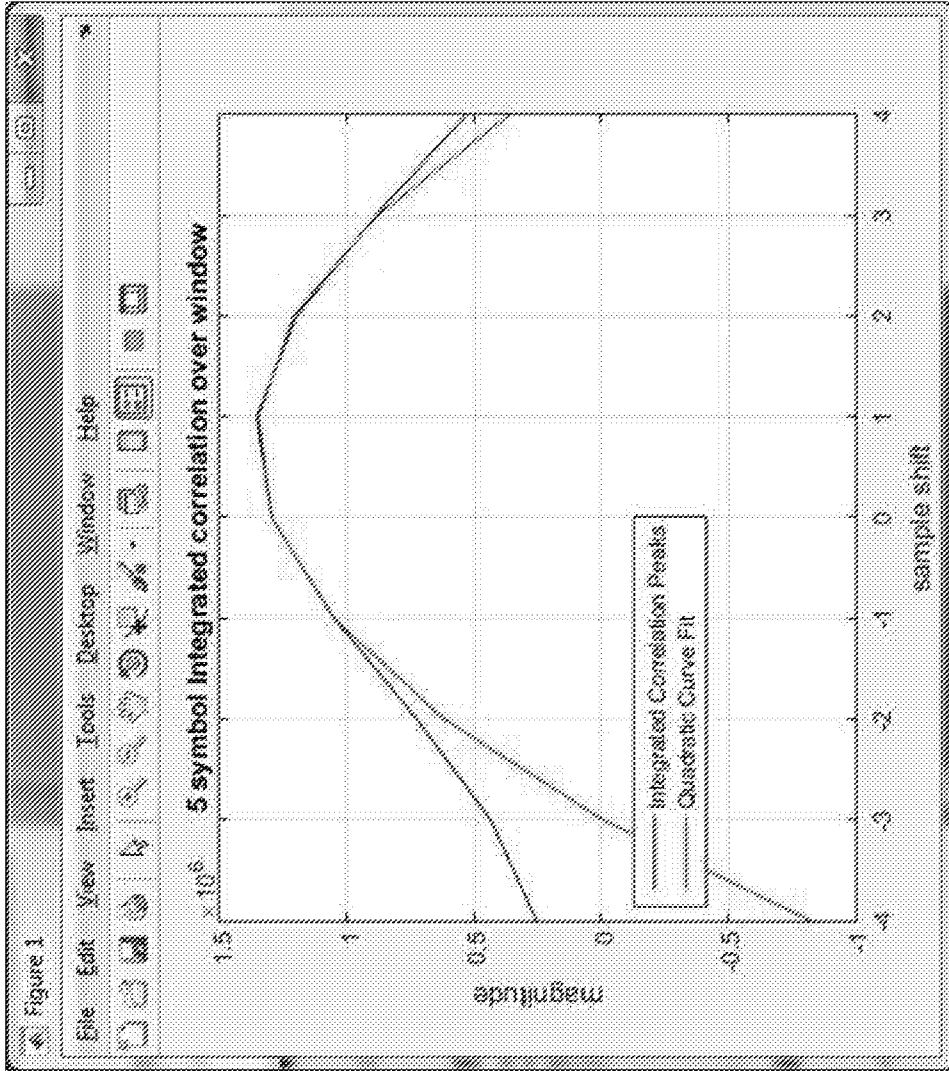

FIG. 20

Integrated Correlation Peak Values Over K (e.g., 5) Symbols,
Quadratic Curve Fit

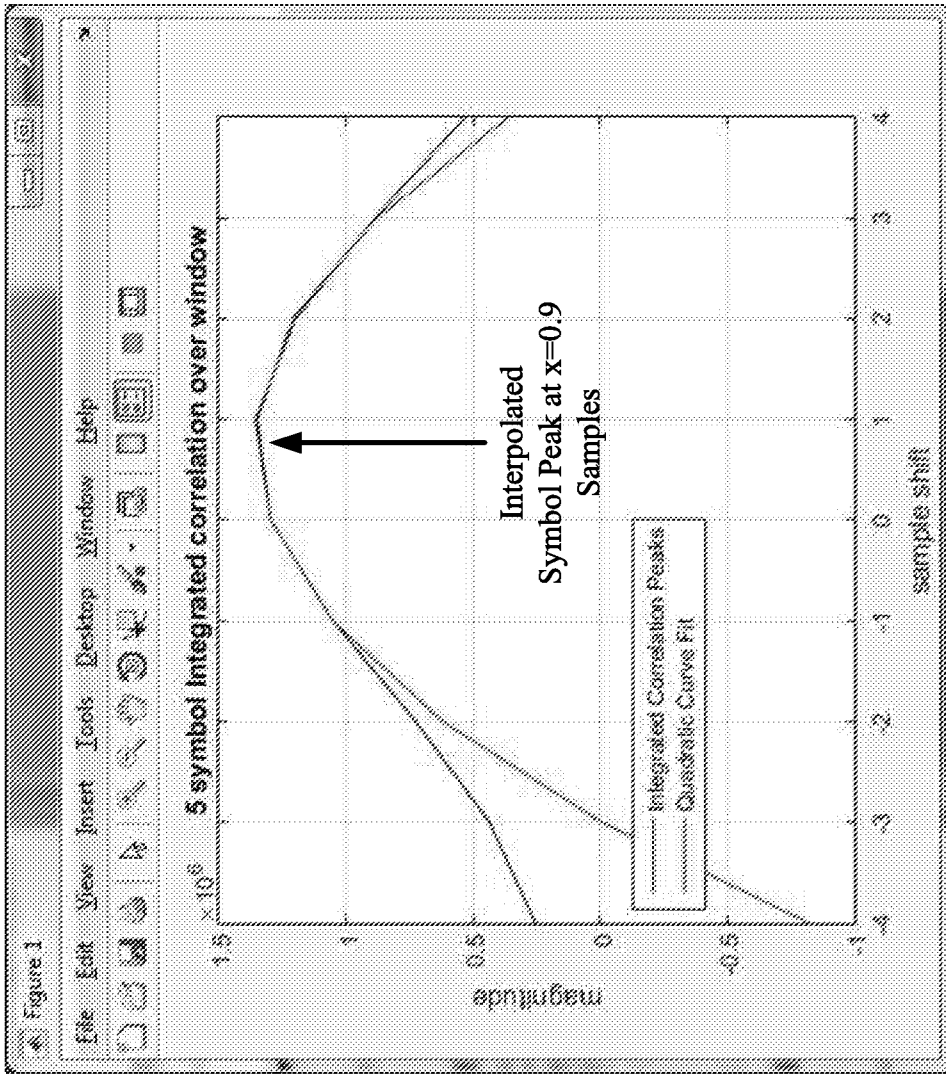
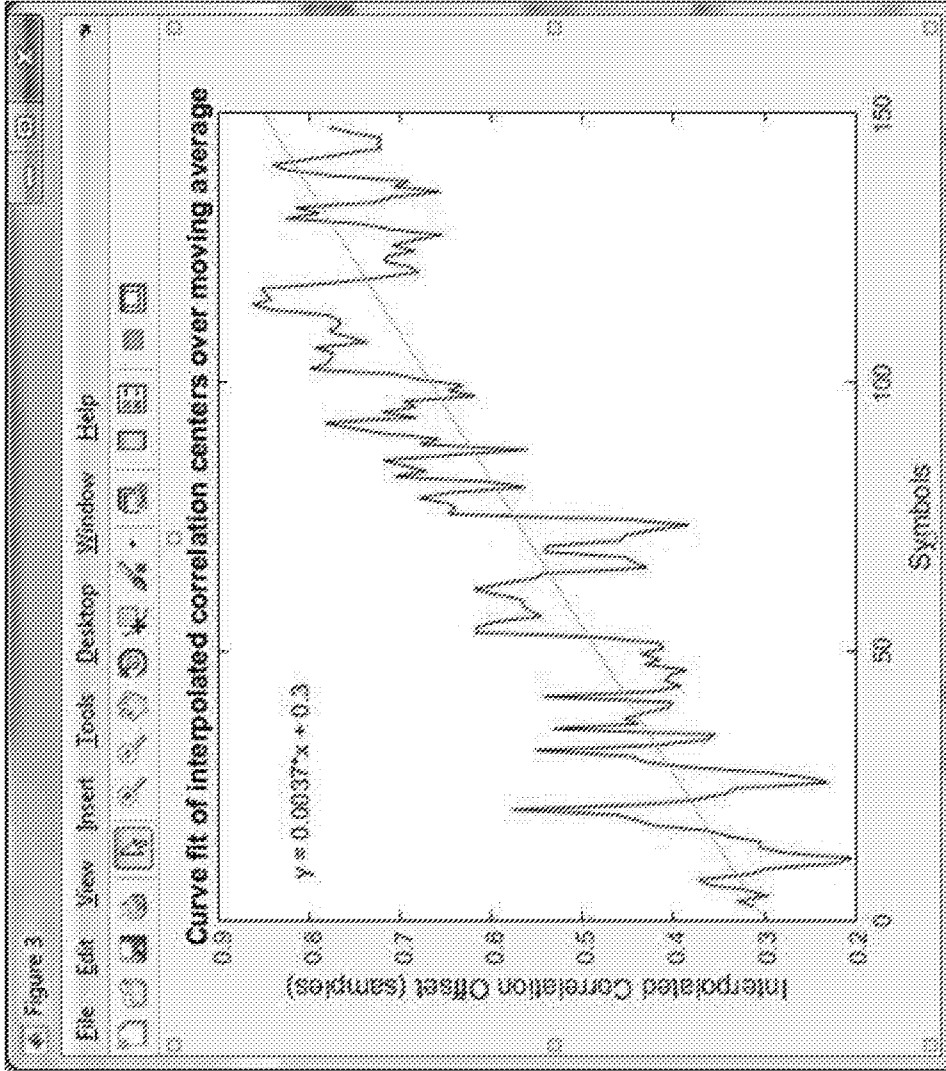

FIG. 21

Curve Fit Of Symbols Peak Sample Offsets



TOA is defined at $x=0$; $TOA=0.3/fs$

FIG. 22

Time Dilation/Contraction

Theoretical comes from $2v/c$ when the beacon and receiver are collocated.

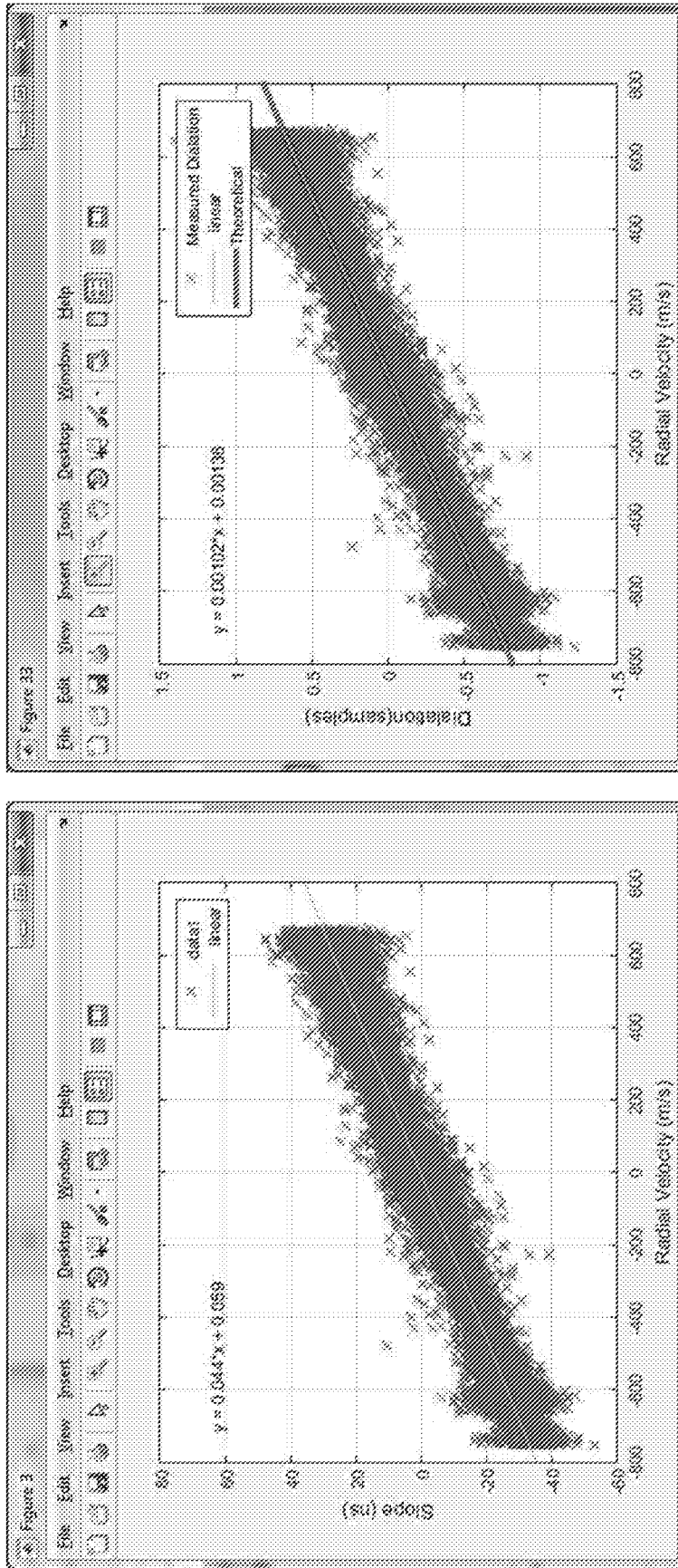

Time Dilation/Contraction is dependent on the radial velocity

FIG. 23

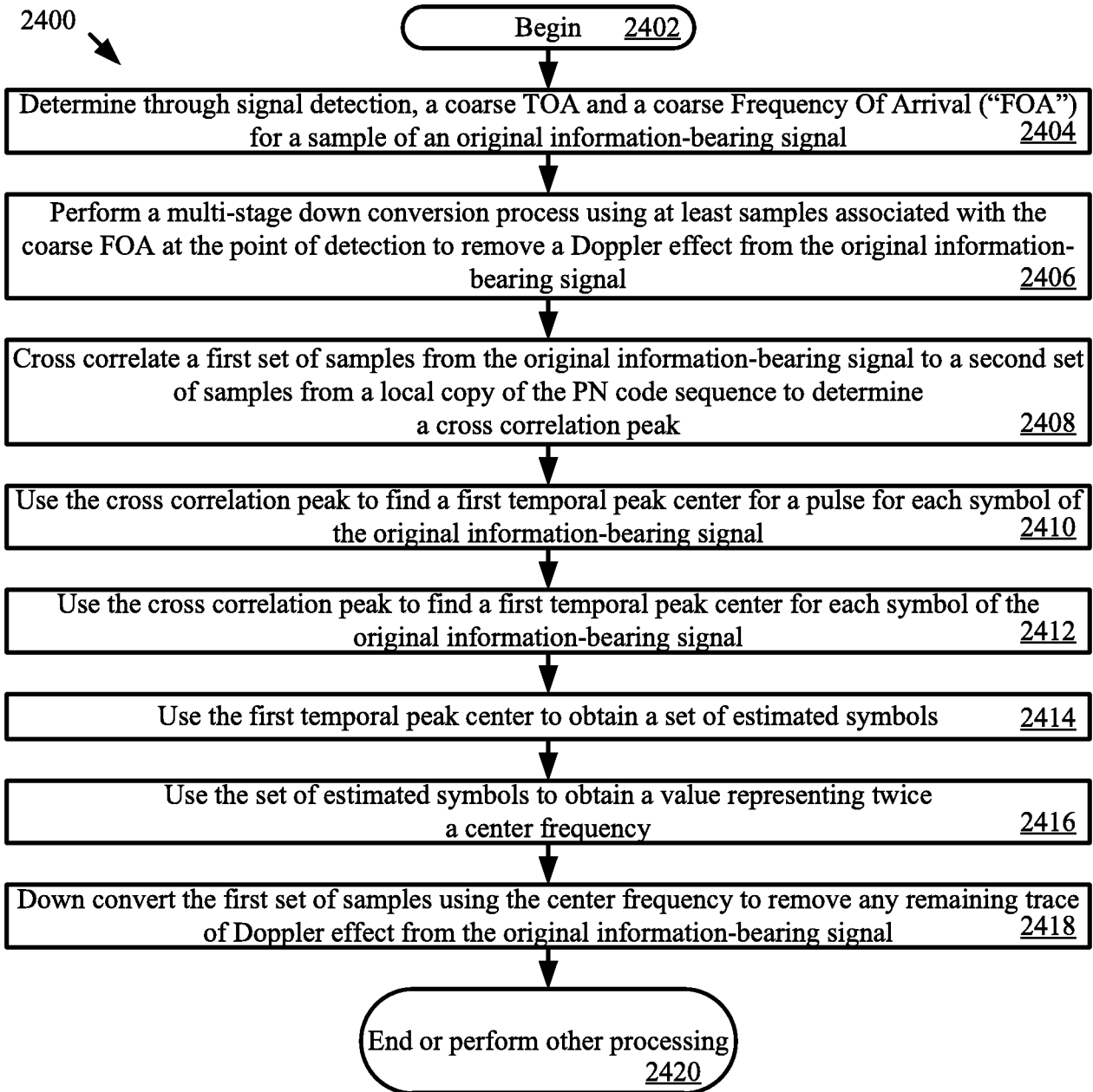

FIG. 24

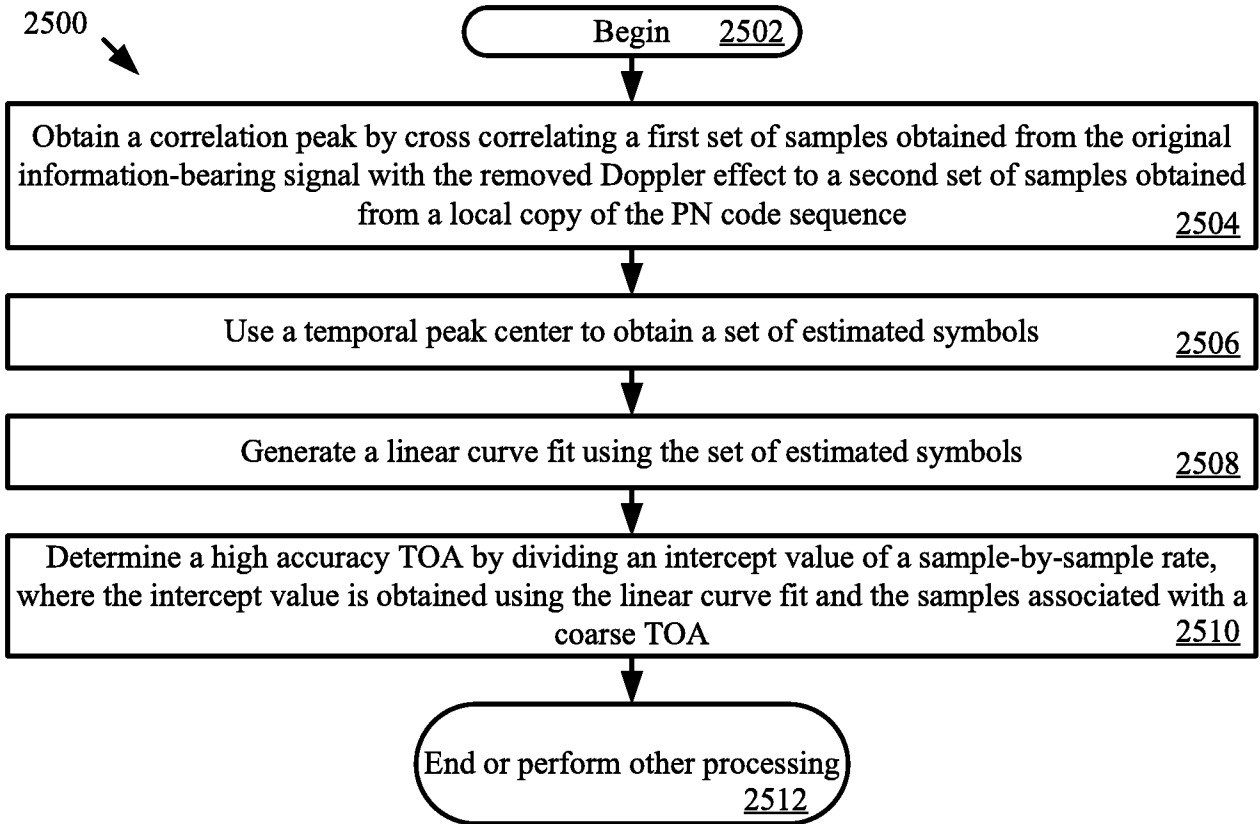

FIG. 25

INTERNATIONAL SEARCH REPORT

International application No.

PCT/US2016/016581

A. CLASSIFICATION OF SUBJECT MATTER

IPC(8) - G01S 5/14, G01S 19/42; H04W 4/02, H04W 64/00 (2016.01)

CPC - G01S 5/0036, G01S 5/0054, G01S 5/021, G01S 19/42 (2016.01)

According to International Patent Classification (IPC) or to both national classification and IPC

B. FIELDS SEARCHED

Minimum documentation searched (classification system followed by classification symbols)

IPC(8) - G01S 5/14, G01S 19/42; H04W 4/02, H04W 64/00 (2016.01)

CPC - G01S 5/0036, G01S 5/0054, G01S 5/021, G01S 19/42 (2016.01)

Documentation searched other than minimum documentation to the extent that such documents are included in the fields searched

US: 701/213; 455/456.1; 342/357.25 (keyword delimited)

Electronic data base consulted during the international search (name of data base and, where practicable, search terms used)

PatBase, Google Patents, ProQuest

Search terms used: location, signal source, time of arrival, accuracy, demodulation, time delay, offsets

C. DOCUMENTS CONSIDERED TO BE RELEVANT

Category*	Citation of document, with indication, where appropriate, of the relevant passages	Relevant to claim No.
Y	US 2003/0008663 A1 (STEIN et al) 09 January 2003 (09.01.2003) entire document	1-8, 11-18
Y	US 2007/0176749 A1 (BOYD) 02 August 2007 (02.08.2007) entire document	1-8, 11-18
Y	US 2004/0057505 A1 (VALIO) 25 March 2004 (25.03.2004) entire document	2, 12
Y	US 2004/0027281 A1 (AKOPIAN et al) 12 February 2004 (12.02.2004) entire document	5, 6, 15, 16
Y	US 2015/0036724 A1 (BASEBAND TECHNOLOGIES INC.) 05 February 2015 (05.02.2015) entire document	7-10, 17, 18
Y	US 2009/0295631 A1 (WU et al) 03 December 2009 (03.12.2009) entire document	7-10, 17, 18
Y	US 5,943,606 A (KREMM et al) 24 August 1999 (24.08.1999) entire document	7-10, 17, 18
A	US 6,353,412 B1 (SOLIMAN) 05 March 2002 (05.03.2002) entire document	1-18

 Further documents are listed in the continuation of Box C. See patent family annex.

* Special categories of cited documents:

"A" document defining the general state of the art which is not considered to be of particular relevance

"E" earlier application or patent but published on or after the international filing date

"L" document which may throw doubts on priority claim(s) or which is cited to establish the publication date of another citation or other special reason (as specified)

"O" document referring to an oral disclosure, use, exhibition or other means

"P" document published prior to the international filing date but later than the priority date claimed

"T" later document published after the international filing date or priority date and not in conflict with the application but cited to understand the principle or theory underlying the invention

"X" document of particular relevance; the claimed invention cannot be considered novel or cannot be considered to involve an inventive step when the document is taken alone

"Y" document of particular relevance; the claimed invention cannot be considered to involve an inventive step when the document is combined with one or more other such documents, such combination being obvious to a person skilled in the art

"&" document member of the same patent family

Date of the actual completion of the international search

23 May 2016

Date of mailing of the international search report

10 JUN 2016

Name and mailing address of the ISA/

Mail Stop PCT, Attn: ISA/US, Commissioner for Patents
P.O. Box 1450, Alexandria, VA 22313-1450

Facsimile No. 571-273-8300

Authorized officer

Blaine R. Copenheaver

PCT Helpdesk: 571-272-4300
PCT OSP: 571-272-7774

INTERNATIONAL SEARCH REPORT

International application No.

PCT/US2016/016581

Box No. II Observations where certain claims were found unsearchable (Continuation of item 2 of first sheet)

This international search report has not been established in respect of certain claims under Article 17(2)(a) for the following reasons:

1. Claims Nos.:
because they relate to subject matter not required to be searched by this Authority, namely:

2. Claims Nos.:
because they relate to parts of the international application that do not comply with the prescribed requirements to such an extent that no meaningful international search can be carried out, specifically:

3. Claims Nos.:
because they are dependent claims and are not drafted in accordance with the second and third sentences of Rule 6.4(a).

Box No. III Observations where unity of invention is lacking (Continuation of item 3 of first sheet)

This International Searching Authority found multiple inventions in this international application, as follows:
See supplemental page

1. As all required additional search fees were timely paid by the applicant, this international search report covers all searchable claims.
2. As all searchable claims could be searched without effort justifying additional fees, this Authority did not invite payment of additional fees.
3. As only some of the required additional search fees were timely paid by the applicant, this international search report covers only those claims for which fees were paid, specifically claims Nos.:

4. No required additional search fees were timely paid by the applicant. Consequently, this international search report is restricted to the invention first mentioned in the claims; it is covered by claims Nos.:

- Remark on Protest**
- The additional search fees were accompanied by the applicant's protest and, where applicable, the payment of a protest fee.
- The additional search fees were accompanied by the applicant's protest but the applicable protest fee was not paid within the time limit specified in the invitation.
- No protest accompanied the payment of additional search fees.

INTERNATIONAL SEARCH REPORT

International application No.

PCT/US2016/016581

Continued from Box No. III Observations where unity of invention is lacking

This application contains the following inventions or groups of inventions which are not so linked as to form a single general inventive concept under PCT Rule 13.1. In order for all inventions to be examined, the appropriate additional examination fees must be paid.

Group I, claims 1-8,11-18, drawn to determining an accurate location of a signal's source of transmission.
Group II, claims 9-10, drawn to a method for determining a high accuracy Time Of Arrival ("TOA").

The inventions listed as Groups I-II do not relate to a single general inventive concept under PCT Rule 13.1 because, under PCT Rule 13.2, they lack the same or corresponding special technical features for the following reasons: the special technical feature of the Group I invention: compute time delay offsets using correlations of PN code windows for each symbol of the original information-bearing signal; determine a high accuracy Time Of Arrival ("TOA") of the detected carrier signal using the time delay offsets; and use the high accuracy TOA to determine an accurate location of the original information-bearing signal's source of transmission as claimed therein is not present in the invention of Group II. The special technical feature of the Group II invention: determine a cross correlation peak, where the PN code represents a signal of interest; using the cross correlation peak to find a first temporal peak center for a pulse for each symbol of the original information-bearing signal; using the cross correlation peak to find a first temporal peak center for a pulse for each symbol of the original information-bearing signal; using the first temporal peak center to obtain a set of first estimated symbols; using the set of first estimated symbols to obtain a value representing twice a center frequency as claimed therein is not present in the invention of Group I.

Groups I and II lack unity of invention because even though the inventions of these groups require the technical feature of determining a high accuracy Time Of Arrival ("TOA"); a Pseudo Noise ("PN") code, this technical feature is not a special technical feature as it does not make a contribution over the prior art.

Specifically, US 2004/0057505 A1 (VALIO) 25 March 2004 (25.03.2004) teaches determining a high accuracy Time Of Arrival ("TOA") (Para. 3); a Pseudo Noise ("PN") code (Para. 6).

Since none of the special technical features of the Group I or II inventions are found in more than one of the inventions, unity of invention is lacking.