

(No Model.)

7 Sheets—Sheet 1.

E. E. WITTER.
CORN HARVESTER.

No. 526,602.

Patented Sept. 25, 1894.

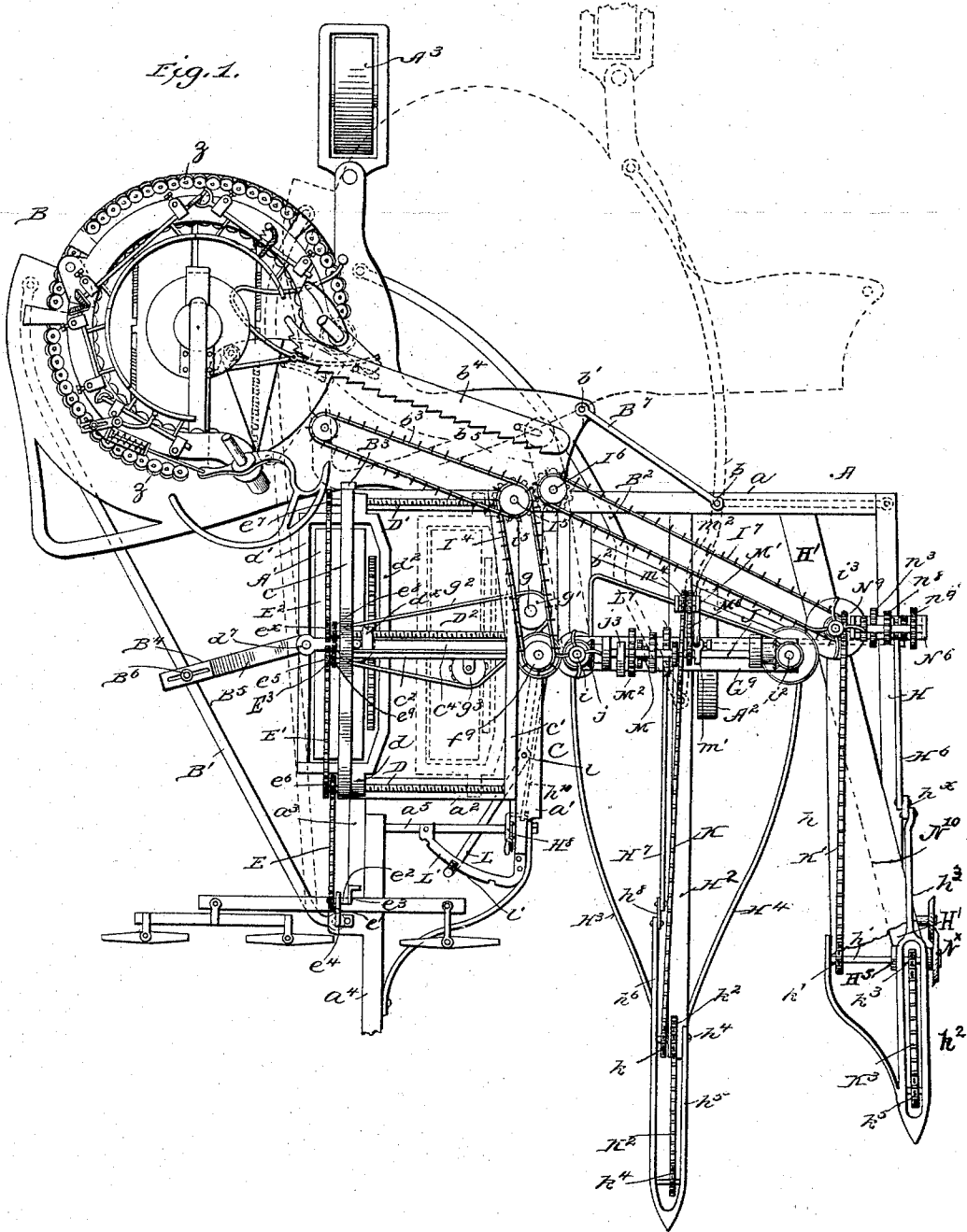

witnesses:

Harry S. Robner.
George C. Cuel.

Inventor:

Ezra E. Witter.

By *Knight Bros.*
Attorneys.

(No Model.)

7 Sheets—Sheet 2.

E. E. WITTER. CORN HARVESTER.

No. 526,602.

Patented Sept. 25, 1894.

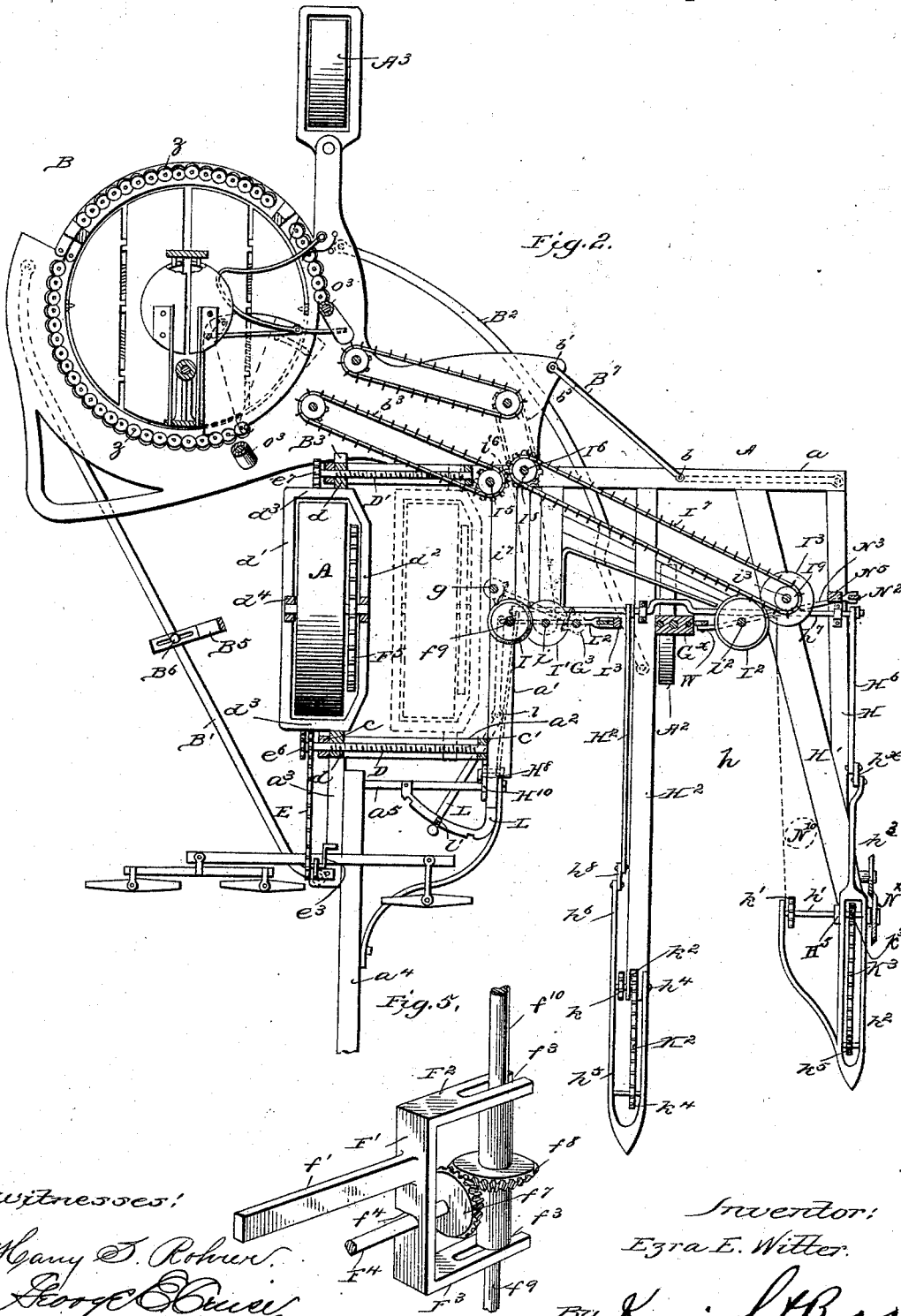

witnesses:
 Harry S. Rohrer.
 George C. Cui.

Inventor:
 Ezra E. Witter.
 By Knight Bros.
 Attorneys

(No Model.)

7 Sheets—Sheet 3.

E. E. WITTER. CORN HARVESTER.

No. 526,602.

Patented Sept. 25, 1894.

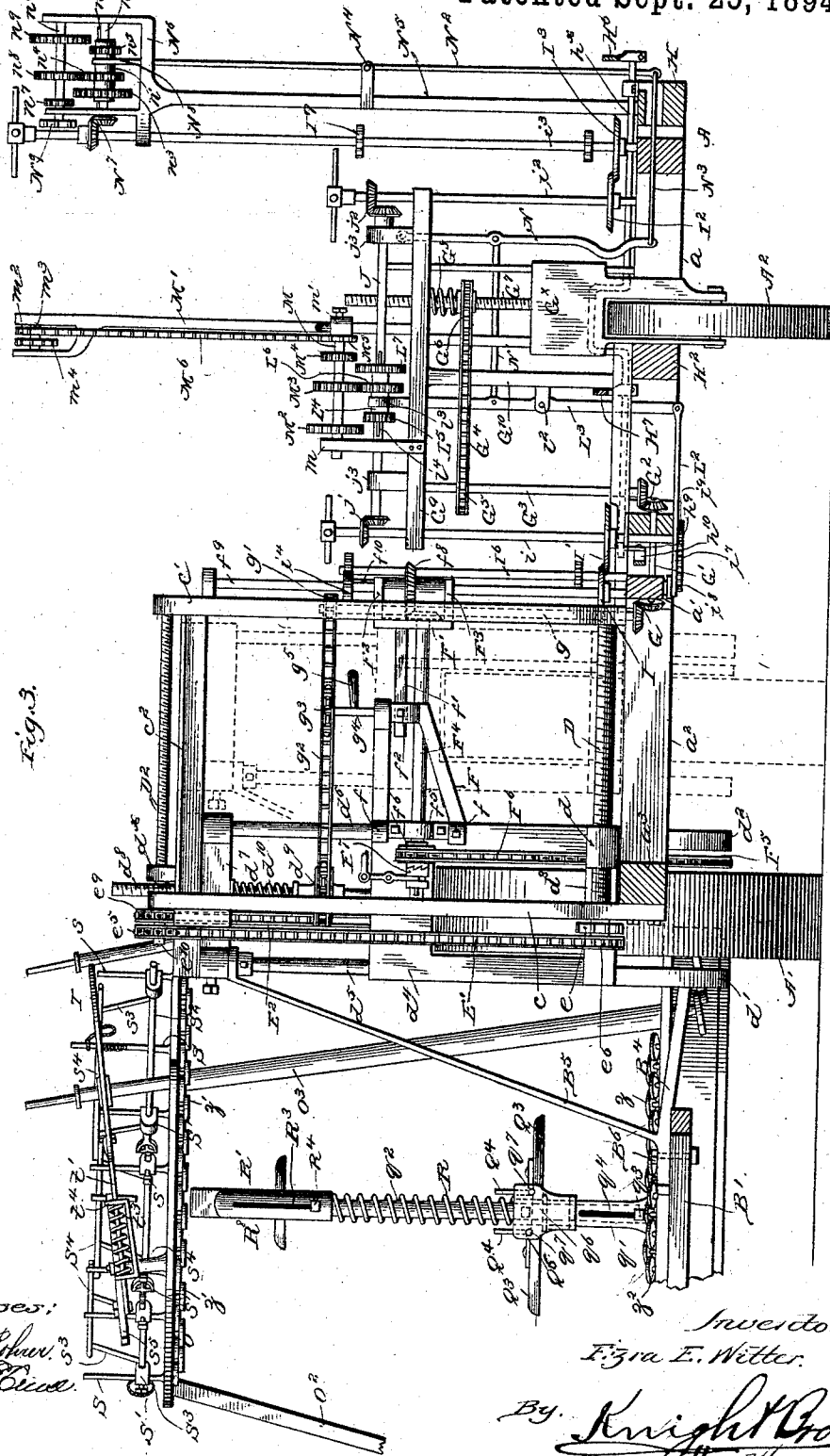

Fig. 3.

witnesses:
 Henry S. Ricker,
 J. P. C. C. C.

Inventor:
 Ezra E. Witter.

By *Knight Bros.*
 Attorneys.

(No Model.)

7 Sheets—Sheet 5.

E. E. WITTER.
CORN HARVESTER.

No. 526,602.

Patented Sept. 25, 1894.

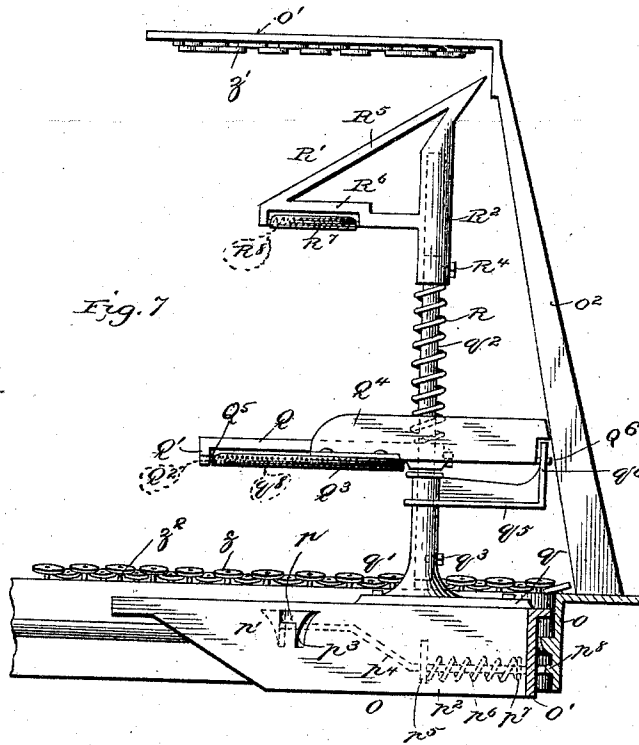

Fig. 7

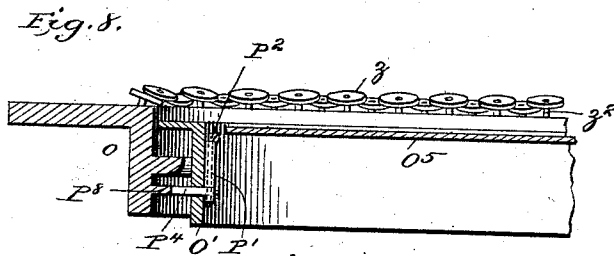

Fig. 8.

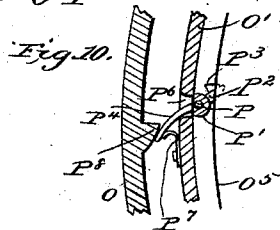

Fig. 10.

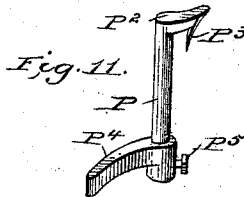
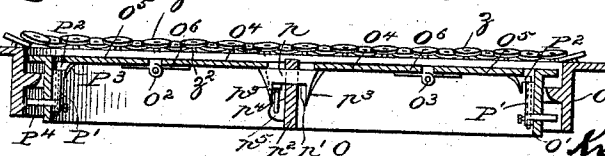

Fig. 11.

Fig. 9.

witnesses:
Harry S. Parker
George C. Cline.



Inventor:
Ezra E. Witter.

Knights & Bates
Attorneys.

(No Model.)

7 Sheets—Sheet 6.

E. E. WITTER. CORN HARVESTER.

No. 526,602.

Patented Sept. 25, 1894.

Fig. 20.

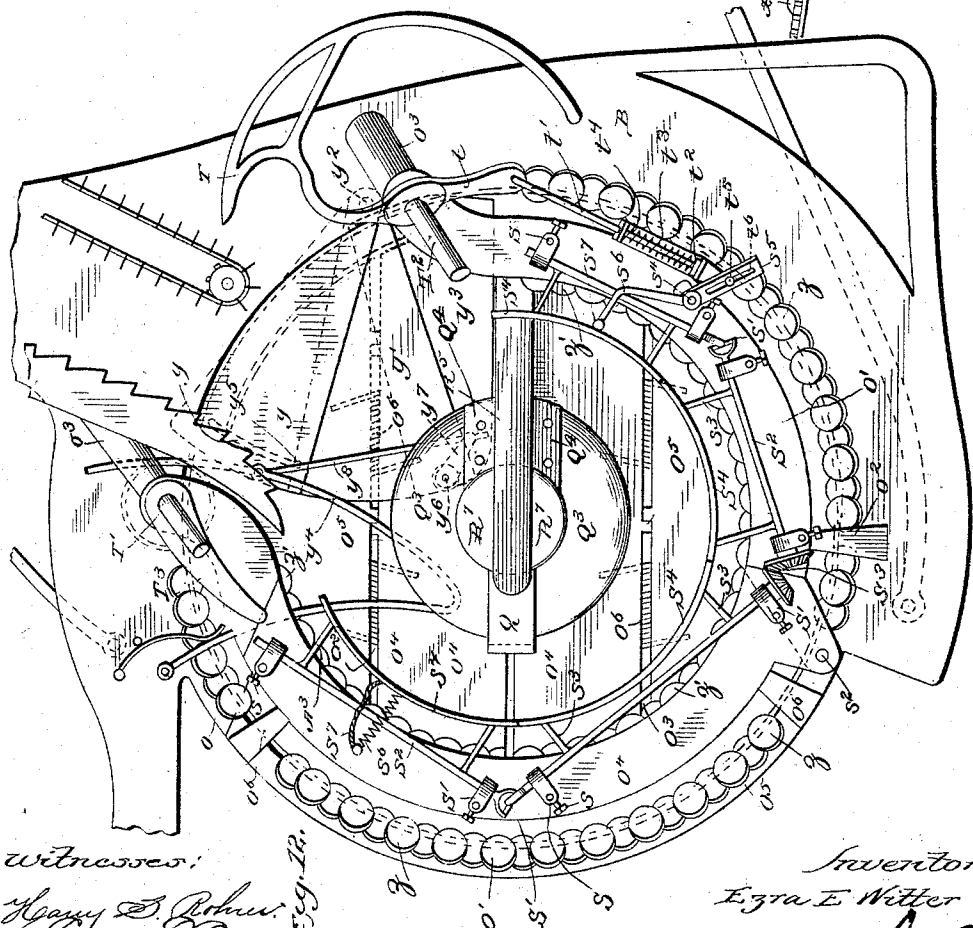
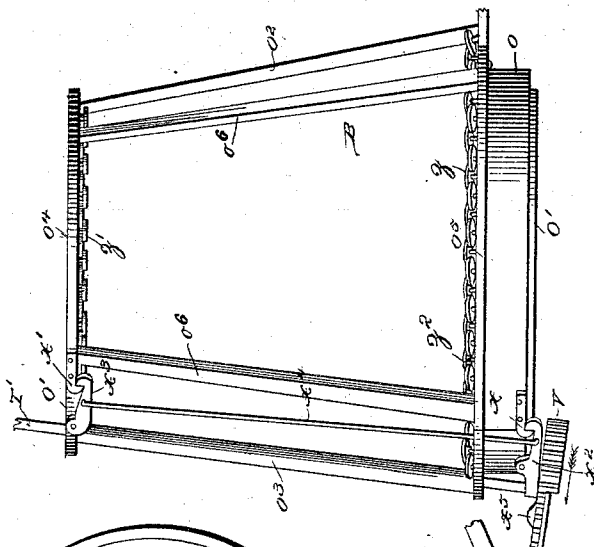

Witnesses:
Henry S. Rohrer.
George B. Bruce.

Inventor:
E. E. Witter
 By *Knight Bros.*
 Attorneys

(No Model.)

7 Sheets—Sheet 7.

E. E. WITTER.
CORN HARVESTER.

No. 526,602.

Patented Sept. 25, 1894.

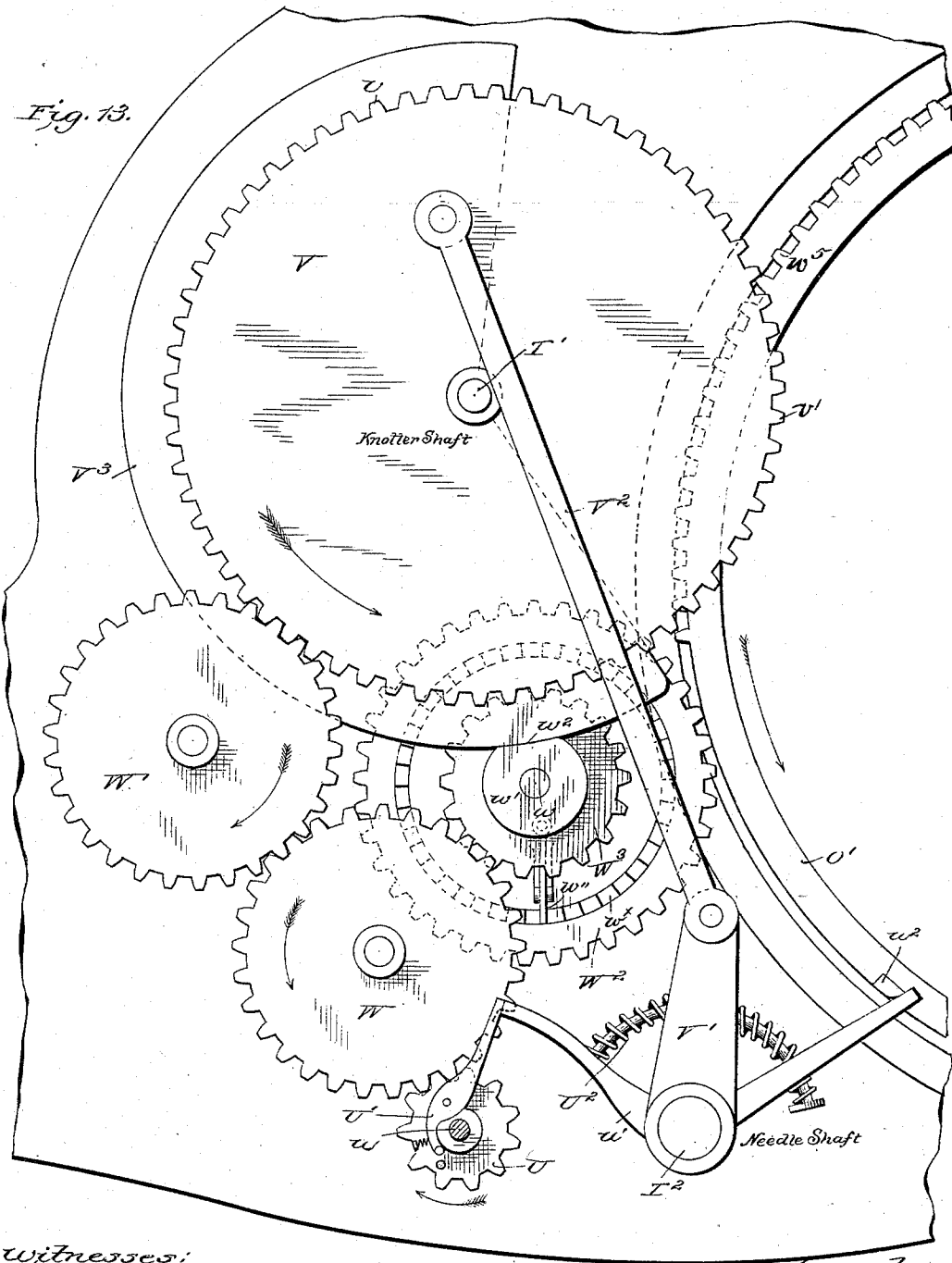

witnesses:

Harry S. Parker.
George C. Crane.

Inventor:

Ezra E. Witter.

By Knight Bros.
Attorneys.

UNITED STATES PATENT OFFICE.

EZRA E. WITTER, OF MILFORD CENTRE, OHIO.

CORN-HARVESTER.

SPECIFICATION forming part of Letters Patent No. 526,602, dated September 25, 1894.

Application filed February 21, 1893. Serial No. 463,200. (No model.)

To all whom it may concern:

Be it known that I, EZRA E. WITTER, a citizen of the United States, residing at Milford Centre, in the county of Union and State of Ohio, have invented certain new and useful Improvements in Corn-Harvesters, of which the following is a specification.

The improvements forming a part of the present invention bear an intimate relation to the general form and construction of the corn-harvesters heretofore patented by me, and numbered 458,088 and 470,609, and I consider them valuable additions thereto.

The most important change over my former patents is that instead of tilting the main frame it is carried level all the time, but to reach the down corn more effectually I provide supplemental movable gathering points.

The present invention further consists in mechanism for changing the speed of the carrier-chains which elevate the down corn. This is essential because as the corn lies away from the machine sometimes, it needs to be moved faster than when it lies athwart or toward the machine.

My invention further consists in the employment of a peculiar construction of compressor on the shock-forming frame, whereby the shock is compressed at top so that it can be bound more tightly.

My invention further consists in an improved form of partition to the revolving-table, it being so constructed that it will not tear the binding off the shock when it drops through the skeleton frame.

Another improvement consists in doing away with the long and cumbersome pawls which move the revolving-table, by the provision of a mutilated gear which does not turn said table until the shock is tied, and then drives it until the vertical partition reaches the line of draft.

My invention also consists in other improvements and parts, all of which will be hereinafter described and then particularly specified in the claims.

In the accompanying drawings:—Figure 1 is a plan view of my improved corn-harvester. Fig. 2 is a partial plan view thereof, parts being shown in section. Fig. 3 is a front elevation, part of the shock-forming frame being broken away. Fig. 4 is a side elevation of

the main frame and part of the shock-forming frame. Fig. 5 is a detail view of part of the front portion of the machine. Fig. 6 is a detail view of a movable gathering point, and devices for operating it. Fig. 7 is a sectional view of a portion of the shock-forming frame showing the vertical partition in elevation. Figs. 8, 9, 10 and 11 are detail views of parts of the revolving-table, showing the catches for supporting the leaves. Fig. 12 is a plan view of the shock-forming frame partly broken away. Figs. 13 and 14 are views showing the mechanism for operating the knoter (not shown) the needle and the revolving-table. Fig. 15 is a detail view showing the catches for the gate which is in the rear of the shock-forming frame and how it is they are actuated.

The framework of the entire harvester is substantially the same as that of the patented machines, referred to, and will not require a detailed description.

Referring to Figs. 1, 2, 3 and 4, it will be seen that the main frame A is supported on the usual master or main driving wheel A', and the grain-wheel A². The shock-forming frame B, which includes the binding mechanism and the mechanism for discharging the shock, is linked to the main-frame, and is supported on the caster-wheel A³ at the rear.

In my last patent, numbered 470,609, I have shown a construction whereby the main-frame is supported on the master-wheel A' and the grain-wheel A² so that it may be adjusted vertically. In the present invention I have shown a somewhat similar arrangement, but in addition have provided means for adjusting the master-wheel frame horizontally or laterally with respect to the main-frame. These parts will now be described.

The rear beam *a* of the main-frame has a forwardly extending beam *a'* at the left end, (when looking to the rear) forming one side of the mouth or entrance C, and from which projects a lateral beam *a²* in front of the master wheel. From beam *a²* projects a short forward beam *a³*, between which latter and the beam *a'* the draft-tongue *a⁴* is pivoted on a rod *a⁵*, connecting beams *a'* and *a³*. Extending up from the rear beam *a* and the front beam *a²* of the main-frame, and spanning the master-wheel at front and rear, are

two arched braces c, c' , connected at top by two transverse bars c^2, c^3 , which are L-shaped in cross-section, and are separated to form between them a guide-way c^4 . Passing through the arched brace c at its lower ends and at its summit, are three screw rods D, D', D^2 , which extend over to the other arched brace c' . The lower screw rods D, D' , pass through screw-threaded openings in the lugs, d , of an oblong frame composed of curved or sagging side-pieces d', d^2 and end-pieces d^3 . The master-wheel is located between the side-pieces d', d^2 , and is journaled in the upright frame or support d^4 . The two upright bars d^5, d^6 , pass through vertical openings in the master-wheel frame, d^4 , and are connected and supported by a cross-piece d^7 at the top. A lug d^8 projects up from the cross piece d^7 through the guide-way c^4 , and is formed with a screw threaded opening for the passage of the screw-bar D^2 . The cross-piece or head-block d^7 is fitted in the guide-way c^4 between the transverse bars c^2, c^3 so that it may slide transversely of the machine and the master-wheel frame d^4 is fitted loosely on the upright bars d^5, d^6 so that it may slide vertically.

As in my last patent above referred to, I project upwardly from the master-wheel frame d^4 a screw-rod d^8 which passes through the cross-piece d^7 , and between the transverse bars c^2, c^3 . Its lower end turns in a socket in the master-wheel frame, and surrounding it between the cross-piece d^7 and a sprocket-wheel d^9 thereon is a strong spiral spring d^{10} , which supports the left side of the machine.

E is a sprocket chain which passes over a sprocket wheel e on the outer end of screw-rod D , and also over a sprocket wheel e' on a crank-shaft e^2 , turned by a crank e^3 and supported in a bracket e^4 at the front end of beam a^3 . A sprocket chain E' passes over a sprocket-wheel e^5 at the top of the arched brace c and over a second sprocket-wheel e^6 on the screw-rod D . Another sprocket-chain E^2 passes over a sprocket-wheel e^7 on the screw-rod D' and also over a sprocket-wheel e^8 on screw-rod D^2 . Chain E^2 is actuated by the chain E' through the medium of a short sprocket-chain E^3 which passes over sprocket-wheels e^8 and e^9 , respectively on the screw-rod D^2 and on the short shaft e^{10} which carries the sprocket-wheel e^5 . The operation of all these parts will be described hereinafter.

In order to carry the drive-shaft, and its gear connection with the operating parts which cut and carry the stalks to the rear, up and down with the master-wheel frame as would be necessary when the machine passes over rough ground or while the machine is being raised or lowered, I provide the following instrumentalities.

F is a movable or swinging bracket hinged at f to the master-wheel frame d^4 . In the outer end of the bracket F is a mortise or recess which receives a slide bar f' which is retained in adjusted position by means of a set-screw f^2 . See Figs. 3 and 5. The outer end of the mov-

able bar f' carries the support for the gear connections above referred to. This support has a vertical portion F' and a pair of horizontally projecting arms F^2, F^3 , provided with longitudinal open slots or recesses f^3 at their outer ends. At one side of the vertical portion F' is a slot or recess f^4 , in which is supported and journaled one end of the horizontal drive-shaft F^4 . The other end of the drive-shaft is supported and journaled in a box f^5 on the master-wheel frame d^4 and carries a loose sprocket-wheel f^6 over which and over a large sprocket-wheel F^5 on the axle of the master-wheel A' , a drive-chain F^6 passes. The sprocket-wheel f^6 is coupled to the drive-shaft by means of a suitable clutch F^7 which may be operated from the driver's seat (not shown) in any preferred manner. The outer end of the drive-shaft F^4 is provided with a bevel gear-wheel f^7 which meshes with bevel-gear wheel f^8 . Wheel f^8 is permitted to slide on upright shaft f^9 but is caused to turn therewith by means of a feather and groove connection, f^{10} indicating the feather. The arms F^2, F^3 , support the gear-wheel f^8 on shaft f^9 , and the slots or recesses f^3 receive said shaft.

g is an upright shaft alongside the shaft f^9 and carries at its top a sprocket-wheel g' around which passes sprocket-chain g^2 which also passes around the sprocket-wheel d^9 on the screw-rod d^8 . The chain g^2 also passes over a sprocket-wheel g^3 on a shaft g^4 supported by a bracket F . g^5 is a lever whereby shaft g^4 may be turned.

Bevel gearing G connects short horizontal shaft G' with the upright shaft g , and bevel gearing G^2 connects it with the upright shaft G^3 which is on the side of the mouth or entrance C opposite the shaft g . A sprocket-chain, G^4 passes around a sprocket-wheel G^5 on the shaft G^3 and a sprocket-wheel G^6 fixed on a screw-rod G^7 , similar to the screw-rod d^8 . Screw-rod G^7 turns in a socket in the vertical frame G^x that supports and provides journals for the grain-wheel A^2 . As upon the screw-rod d^8 of the master-wheel, I place upon the screw-rod G^7 a spiral spring G^8 , located between the sprocket-wheel G^6 and an upper horizontal beam G^9 supported by an upright G^{10} . The screw-rod G^7 engages in a screw-threaded opening in the upper beam G^9 .

When it is desired to raise and lower the main frame with reference to the wheels, to adjust the height of cut, the lever g^5 is revolved, thus operating the chain g^2 , the screw-rod d^8 , and causing the latter to act on the cross-piece or head-block d^7 . This same operation also actuates upright shaft g , horizontal shaft G' , upright shaft G^3 , chain G^4 , and screw-rod G^7 . The screw-rod G^7 acts on the beam G^9 similarly to and simultaneously with the screw-rod d^8 or cross-piece d^7 and thus the main frame is raised or lowered on the supporting wheels, according to the direction in which the shaft g^4 is turned by lever g^5 .

The horizontal movement of the master-wheel A' and the parts that must necessarily move with it is accomplished by turning the crank e^3 . This will cause the horizontal screw-rods D, D', D², to move simultaneously through the medium of the sprocket-chains connected therewith. These screw-rods will then act through the lugs d and d^x , and cause the oblong frame d' , d^2 , d^3 , to move, and the cross-piece or head-block d^7 to slide in the guide-way c^4 between the parallel L-shaped bars c^2 , c^3 , bringing these parts d' , c^2 , c^3 , and those interposed and connected with them to the position shown in dotted lines.

Before attempting to move the master-wheel transversely of the machine it will be necessary to loosen the set-screw f^2 so that the bar f' and the support for the gear connections may be slid inwardly to release the arms F², F³ from the upright shaft f^3 , so that parts f' , F', F², F³, and the bracket F may be swung forwardly out of the way.

H is a forwardly projecting beam on the right side of the machine, and H' is a diagonal beam running thereto from the rear beam A. Between beams H, H' and a' is a forwardly projecting beam H². This beam H² has secured thereto the guide-rods H³, H⁴, as in my other patents. The mouth or entrance C is located on the left of guide-rod H³, and the mouth or entrance h is located on the right of guide-rod H⁴.

Secured to the front end of the beam H' are boxes H⁵ in which is journaled a hinge-rod h' , on which latter is pivoted a depressible gathering point h^2 having a rearwardly extending lever h^3 . See Figs. 1, 2 and 6. In the front end of the beam H² is journaled a hinge-rod h^4 , on which is pivoted a second depressible gathering point h^5 also having a rearwardly extending lever h^6 . These gathering points h^2 , h^5 , are depressed or raised by means of a transverse rock-shaft h^7 , connected with the levers h^3 and h^6 , by means of rock-arms H⁶, H⁷, and pivoted links h^x , h^8 . For operating the rock-shaft I employ a lever H⁸, held at any desired point by means of a pawl H⁹ and a toothed quadrant H¹⁰. The lever is fulcrumed on the rod a^5 , and extends downwardly and is connected with a lateral projection or lug h^9 on the rock-shaft h^7 , by means of a connecting bar h^{10} .

The upright shaft f^3 , and parallel shaft i alongside it, both located at the rear of the mouth C, carry cutter-disks I, I', whereby the stalks entering said mouth are severed. The parallel upright shafts i^2 , i^3 , at the rear of mouth h carry cutter-disks I², I³. Toothed endless carrier chain I⁴ passes over wheel i^4 on shaft f^3 and operates upright shaft I⁵ at rear beam a through wheel i^5 thereon. Toothed gearing i^6 communicates motion to shaft I⁶, being located at the lower end thereof and of shaft I⁵, while a sprocket chain i^7 passing around sprocket-wheel i^8 on shaft I⁶ communicates motion to the cutter shaft i through sprocket-wheel i^9 . Toothed endless carrier-

chain I⁷ passes around wheel I⁸ on shaft I⁶ and operates cutter-shaft i^3 through the wheel I⁹. Cutter shaft i^2 is operated by horizontal shaft J leading from cutter shaft i .

j is bevel gearing connecting shaft i with shaft J, and j^2 is bevel gearing connecting shaft J with shaft i^2 , while j^3 indicates the boxes on beam G⁹ in which the shaft J is journaled.

In practice it is found that down-corn lying at different angles to the machine must be treated differently with respect to elevation in order to bring it in an approximately upright position before it is cut. Corn which lies away from the machine will be cut before it is elevated and so go through endwise, and the same with corn which lies toward the machine. Now in order to effectuate the entering of the stalks in upright position, I make a change of speed by providing a shiftable speeding device for the toothed or lugged elevator chains K, K'. These chains pass over sprocket-wheels k , k' at their lower ends and operate the short toothed elevator chains K², K³, of the depressible or supplemental gathering points h^5 , h^2 .

k^2 , k^3 , are the sprocket-wheels at the inner ends of chains K², K³, and k^4 , k^5 the wheels at their outer ends. Wheels k , k^2 , and k' , k^3 , are fixed on their respective shafts, *i. e.*, the hinge-rods h' , h^4 .

The mechanism for changing the speed of the lugged elevator-chains K, K', is operated by means of a horizontal lever L pivoted at l to the beam a' , and held to set position by means of a catch l' which takes into notches in the horizontal rack L'. Connecting rod L² extending from the lever L operates the vertical lever L³, pivoted at l^2 intermediately of its ends. The upper end of the lever L³ is formed with a fork l^3 which embraces a tubular section or sleeve L⁴ and may cause the same to slide on the shaft J. This tubular section or sleeve L⁴ is provided with three cog-wheels L⁵, L⁶, L⁷, of graduated sizes, wheel L⁵ being the smallest, wheel L⁷ the largest, and wheel L⁶ the intermediate one. These cog-wheels are caused to revolve with shaft J by means of a tongue and groove connection, between the latter and the sleeve, L⁴, l^4 being the tongue. Above the shaft J is another parallel horizontal shaft M journaled in boxes m , m' , projecting from the beam G⁹ and the standard M' on the beam H². Carried by the shaft M are three cog-wheels M², M³, M⁴ of graduated sizes, which may intermesh with the other graduated wheels, wheel M² being the largest, wheel M⁴ being the smallest, and wheel M³ the intermediate one. Also on the shaft M is a sprocket-wheel M⁵ over which a sprocket chain M⁶ passes and extends up to and passes over a sprocket-wheel m^3 on a short shaft m^3 located at the top of standard M'. The sprocket-wheel m^4 over which the upper end of the elevator chain K passes is also carried by the shaft m^3 , so that when chain M⁶ is operated the elevator chain K and

the supplemental forward chain K^2 are both operated to elevate the down corn.

N is a vertical lever pivoted at its upper end to the beam G^3 , and pivotally connected with the lever L^3 by a rod N' . The lower end of the lever N is pivotally connected with the lower end of vertical lever N^2 by means of a connecting rod N^3 . The lever N^2 is located on the right side of the machine and is pivoted at N^4 , intermediately of its ends, to the standard N^5 which rises from the beam H . At the upper end of the standard N^5 bearings in a frame N^6 are provided for a short shaft n which is connected with the cutter-shaft n^3 by bevel gearing N^7 . Located on the shaft n is a sleeve or tubular section n' , which is caused to turn therewith by a tongue and groove connection, n^2 being the tongue. On the sleeve n' are three graduated cog-wheels n^3, n^4, n^5 , similar to those previously described, only in reversed order, obviously n^3 being the large cog-wheel, n^5 , the small one and n^4 the intermediate one. The cog-wheels may be slid along the shaft n by the fork n^8 at the top of the lever N^2 . Journaled in the frame N^6 , above the shaft n , is a short shaft n^6 , carrying three graduated cog-wheels n^7, n^8, n^9 , which may intermesh with the graduated wheels n^3, n^4, n^5 . n^7 is the smallest wheel, n^9 the largest, and n^8 the intermediate wheel.

The shaft n^6 when in motion, operates the elevator chain through the sprocket-wheel N^9 thereon and over which its upper end passes, while said chain operates the supplemental forward chain K^3 . The latter operates the side cutters N^x , and the endless chains K^3, K' , carry the stalks severed by these cutters up onto the chute N^{10} and into the mouth h in approximately vertical position, as in the patents referred to.

From the description of the elevator chains K, K' , and the parts which operate them it is evident that by properly moving the lever L either the small cog-wheels L^5, n^5 , may be caused to mesh with the large cog-wheels M^2, n^9 or the intermediate cog-wheels L^6, n^4 with the intermediate cog-wheels M^3, n^8 , or the large cog-wheels L^7, n^3 with the small cog-wheels M^4, n^7 , thus changing the speed of said chains.

The shock-forming frame B is connected to the main frame by long links B', B^2 , the former being located on the left or stubble side and the latter on the right side of the machine. This allows the shock-forming frame to be swung around the master-wheel A' to a position nearly central of the main-frame, when the machine is to pass through gateways or between stumps. See dotted lines, Fig. 1. The link B' is much longer than the other and is pivoted to the main-frame as far forwardly as possible, so that it may be swung around together with the shock-forming frame to which it is pivoted as far rearwardly as possible.

The shock-forming frame B passes at its

front edge between and is guided by the lugs B^3 on the beam a of the main frame.

To more effectually sustain the weight of the shock-forming frame on the master-wheel and cause the same to move with the master-wheel when the screw-rods D, D', D^2 , are operated, I employ a hinged support consisting of an arm B^4 and a brace B^5 . This hinged support is pivoted on the upright bar d^3 , and it is connected to the link B' by slot and pin B^6 .

Attached to the rear beam a by pivot b is a bar B^7 , which is connected to the shock-forming frame by a removable bolt b' , to permit the bar to be swung into the position shown in dotted lines when the shock-forming frame is to be laterally shifted.

The corn entering the mouths C, h , is severed by the cutters, and is carried back by the endless chains I^4, I^7 , through the passages formed between the chains and the guide-frame b^2 , and out through the opening between the vertical shafts I^5, I^6 , and onto the floor of the shock-forming frame B . From this point the stalks are carried back onto the revolving shock table O by means of the toothed endless chain b^3 and the serrated carrying bar b^4 as in my latest patent. The carrying bar b^4 is operated by a short sprocket-chain b^5 leading from the shaft I^6 , and the chain b^3 is operated from the shaft I^5 .

I will now describe the improvements in the shock-forming frame and its attachments.

As in my former patents the revolving shock table O has a circular skeleton frame O' open at the rear, and turns within the curved base o of the shock-forming frame.

O^2, O^3 , are the rearwardly projecting hinge-rods on which the leaves O^4, O^5 , of the table are pivoted and on which they are upheld in horizontal or normal position by the springs O^6 coiled upon the rods.

O^4 indicates the inner pair of leaves and O^5 the outer pair. The outer leaves O^5 are supported by means of pivoted catches. See Figs. 8, 9, 10 and 11. These catches each comprise a vertical pivot pin P which is journaled in a bearing P' projecting from the inner side of the frame O' of the table.

P^2 is a lateral projection at the top of the pivot-pin P having at its outer end a pendent cam-faced piece P^3 . The lower end of pivot-pin P receives a trigger-arm P^4 secured to it by a set-screw P^5 . From above, see Fig. 10, it will appear that the lateral projection P^2 and the trigger-arm P^4 extend diametrically opposite. The trigger-arm passes through an opening P^6 in the frame O' and is thrown normally outward by a spring P^7 between it and said frame. When the trigger-arm P^4 of each catch is thrown outward the lateral projection P^2 is thrown inward, thereby supporting the leaves O^5 so that they may uphold the incoming stalks. When the table is revolved to the proper point to dump the bound shock, cam-faced lugs P^8 on the inner side of the base o trip the trigger-arms P^4 forcing them inwardly, against the action of the springs,

and release the lateral projections P^2 from the leaves O^5 permitting them to open. The springs will again throw the lateral projections P^2 inwardly, but when the leaves O^5 are returned to normal position by their springs O^6 , their edges will act on the cam-faced pieces P^3 and throw the lateral projection inwardly so that the leaves may pass.

The catch for the central pair of leaves O^4 , see Figs. 7 and 9, consists of a pivoted button p located in an opening p' in the central rearwardly extending bracket p^2 forming part of the skeleton frame O' . The outer ends of the button p are provided with pendent cam-faced pieces p^3 similar in shape and function to those of P^3 of the outer catches. A slide-rod p^4 extending alongside the bracket p^2 and guided through a perforated lug p^5 at the side of the latter is pivoted at its inner end to one end of button p , while its outer free end passes through an opening in the frame O' . Coiled around the slide-rod p^4 is a spring p^6 , located between the lug p^5 and a projection p^7 on the slide-rod, the tendency of said spring being to project the free end of the slide-rod through the opening therefor, and draw the ends of the button p under the edges of the inner leaves O^4 , thereby supporting them. Simultaneously with the release of the catches from the outer leaves, the catch of the inner leaves is released by means of a cam-faced lug p^8 on the inner side of the base o which comes in contact with the outer end of the slide-rod, and forces it inward against the action of spring and turns the button p , thus permitting leaves O^4 to drop.

As in my previous patents, I provide the revolving shock table with a central partition, against which the incoming stalks are packed, which causes the table to revolve within the outer frame. Besides the base o the outer frame is composed of the usual top o' , posts o^2 securing the latter to base o , the hollow columns o^3 , in which the knotter and needle-shafts revolve, the upper gate member o^4 , the lower gate member o^5 , and the posts o^6 connecting the gates. In the present instance, see Figs. 3, 7, and 12, said central partition is constructed as follows:— q is the foot-plate secured to bracket p^2 in any suitable way. Extending upwardly from the foot-plate q is a hollow support q' , into which the lower end of the standard q^2 is inserted and in which it may be adjusted in height by means of a set-screw q^3 passing through a longitudinal slot q^4 in the support q' and entering the standard. At the top of the support q' is located a forwardly projecting ribbed arm q^5 having a short vertical extension or lug q^6 provided with a pair of perforations q^7 . The standard q^2 is passed loosely through an opening in a rearwardly extending arm Q provided at its outer end with a downward extension or lug Q' . The latter has a pair of perforations Q^2 (shown in dotted lines) which are coincident or in line with the perforations q^7 . The lower semi-circular formers Q^3 have fixed to them

extensions or plates Q^4 which extend longitudinally forward and laterally upward at right angles from the formers, as is clearly shown in Figs. 2 and 7. The plates or extensions Q^4 are preferably formed with flanges by means of which they can be conveniently secured to the formers as shown in Fig. 2. The formers Q^3 are provided with pivot-pins Q^5 which have bearing in the perforations of the lug Q^2 , while the extensions Q^4 are provided with pivot-pins Q^6 which have bearing in the opposite perforations of the lug Q^6 . The formers Q^3 and their trough-shaped extensions Q^4 are upheld by springs q^8 , (shown in dotted lines in Fig. 7,) as clearly set forth in my former patents. The extensions Q^4 serve to limit the movement of the formers Q^3 on their pivots by engaging the upright q^2 and extension q^5 at the extremes of their movement, and also to more effectually open the shock when it is dropped upon the ground, so as to make an easy exit for it and render it less liable to catch on the formers.

Coiled around the standard q^2 and resting upon the arm Q is a spiral spring R which affords a resilient support for the depressible crowning-piece R' of the partition. This crowning-piece is composed of a tube R^2 which fits over the upper end of the standard q^2 and which has a longitudinal slot R^3 through which a pin or set bolt stud R^4 from the standard projects. Projecting rearwardly from the top of the tube R^2 is a downwardly slanting bar R^5 , the lower end of which is connected with the tube by a horizontal bar R^6 . To the bar R^6 the upper semicircular formers R^7 are pivoted, and these are upheld by the springs R^8 . (Shown in dotted lines in Fig. 7.) The object of this depressible crowning-piece R' is to provide a resilient support so that when the shock is dropped the binding will not be torn off.

In order that the shock may be bound more tightly at the top, I provide a compressor now to be described, reference being had to Figs. 1, 3 and 12. The compressing attachments are located on the top o' of the shock-forming frame and on the top member o^4 of the gate.

S indicates vertical pillars for the support of the vertically adjustable boxes S' , which are held in position by the set-screws s .

S^2 are horizontal rock-shafts which journal in said boxes and are connected by universal joints s' , excepting at a point located above the hinge-joint of the gate, where the contiguous ends of the shaft are connected by intermeshing bevel-gears S^3 . These bevel-gears permit the shafts to operate simultaneously, and also to separate when the gate is swung on its hinge s^2 , Fig. 12. Projecting upwardly and inwardly from these rock-shafts S^2 are arms s^3 . The upper ends of the arms carry curved compressor segments S^4 forming a continuous curve which is a complete circle, when viewed from the top, with

the exception that the portion opposite the entrance to the shock-forming frame is open. The number of compressor segments S^4 corresponds to that of the rock-shafts S^2 which carry them, and they overlap at their extremities, alternate ones being situated on a plane above that of their intervening neighbors. Thus placed their ends will not interlock when they are operated. To actuate these segments S^4 at the proper time and simultaneously I project from the hub of the needle T an arm t , to which a rod t' is pivoted, having at its outer end a head t^2 .

s^4 is a slanting pivot-bolt conforming to the slant of the needle-shaft. On this pivot-bolt turns a bell-crank lever, one end of which s^5 is connected with the rod t' , and the other end s^6 runs grainward and is formed with an upward extension s^7 which presses against the compressor segment nearest the needle. To form a resilient or elastic connection between the bell-crank lever s^5 , s^6 and rod t' I surround the latter with a spiral spring t^3 located and confined between the head t^2 and one end of a pivoted piece t^4 , through one end of which the rod passes. The other end of the piece t^4 is connected to the arm s^5 of the bell-crank lever by a pivot or set-screw t^5 which passes through a slot t^6 in said arm.

It will be apparent from this description that when the needle T moves forward the compressor segments S^4 are all simultaneously operated to press tightly together the top of the shock so that a tight bind may be effected.

To support the compressor-segments of the gate in proper position, when the gate is opened I attach to one of the segments S^4 and to the top member of the gate, a spring S^6 and a cord or strap S^7 .

T^1 is the knotter-shaft and T^2 the needle-shaft, both moving within the columns o^2 , o^3 , on each side of the entrance of the shock-forming frame.

No knotter is shown, but an ejector discharger T^3 is shown on the knotter-shaft, which at the proper time forces the shock rearwardly.

In practice it is found best to bind the shock before the table is moved by its actuating mechanism, after the shock is fully made. The devices for causing the knotter, needle and table actuating mechanism to operate at the proper time are similar to those described in my before-mentioned patents, and they are hence not fully shown, nor will they be described at length. It will be sufficient to state that U is the loose cog-wheel on continuously revolving shaft u , U' is the trigger, u' the detent or bell-crank pivoted on the needle-shaft T^2 , and U^2 is the spring the force of which the lug u^2 on the frame O' of the table counteracts when it comes in contact with one end of said bell-crank so as to release the other end from trigger U' and permit the wheel U to revolve a few times. See Figs. 13 and 14.

V is the gear-wheel on the lower end of the knotter-shaft T^1 , and V' is the crank-arm on the needle-shaft T^2 , these two, the gear-wheel and crank-arm, being connected by pitman V^2 . The gear-wheel V is formed on its lower portion with a continuous series of cogs v , and the upper portion is formed with a semi-circular series of cogs v' . The semi-circular series of cogs v' and the ones v directly below them are in reality the same cogs, but are described as separate so as to distinguish one series from the other. Located on the opposite side of the wheel V to the upper cogs v' and on a plane between that of the cogs v and v' , (imagining them as two sets of cogs,) is a curved peripheral flange V^3 . Inter-meshing gear-wheels W , W' , respectively mesh with the cog-wheel U and with the circular series of cogs v . Located on a journal w is an independent and intermittently revolved large gear-wheel W^2 and which has a series of ratchet teeth w^x near the base of its gear teeth and a smaller gear-wheel W^3 carries a spring-actuated dog, and formed on its hub is what may be termed a Geneva stop gear, consisting of a boss or circular enlargement w' having a cut-away or recess w^2 in its periphery conforming to the curvature of the peripheral flange V^3 . This cut-away w^2 receives the edge of the flange. When the shock is fully made and the tripping mechanism is actuated the gear-wheel W^2 has engaged the rack-teeth w^5 of the revolving table O' and when the circular flange V^3 of the wheel V has passed the cam portion on the hub of wheel w^3 the same begins to revolve and the spring-dog w'' catches in the ratchet-teeth of wheel W^3 and drives it forward with it until arrested by the samson wheels W^3 and V driving the revolving table home.

The construction of the actuating mechanism for the knotter-shaft, needle-shaft and table being as described, I will now proceed to describe its operation.

Wheel U being set in motion, which occurs just as the revolving table is about completing the revolution imparted to it by the incoming stalks, gear-wheels W , W' , are operated to cause the large gear-wheel V to rotate which operates the knotter, not shown, and the needle. During a little more than the first half of the revolution of wheel V , the flange V^3 is preventing the rotation of the wheels W^2 , W^3 , caused by the edge of the flange being in engagement with the side w^2 of the cam. As soon as the flange passes the cam, the circular series of cogs v' commence to act on the small gear-wheel W^3 , and continue to rotate the latter until the flange comes around again, at which moment the actuating mechanism is brought to rest. The revolution of the gear-wheel W^3 moves gear-wheel W^2 through the medium of the ratchet-teeth on gear-wheel W^2 and the spring-dog arm on gear-wheel W^3 and brings its spring-dog arm against the ratchet-teeth w^x , imparting and insuring an initial movement to the

revolving table, and causing the series of teeth or cogs w^5 on the latter to be driven home. The latter will now positively rotate the table until the shock is dumped or deposited on the ground, which is permitted by the opening of the leaves O^4, O^5 . Besides having on the lower member o^5 of the gate a projection or hook x as in my last patent, I place a similar projection or hook x' upon the upper member o^4 . See Fig. 15. The lower pivoted catch x^2 and the upper pivoted catch x^3 , which catches respectively engage the projections or hooks x, x' , are connected by a rod x^4 , which causes the catches to be released simultaneously, to allow the gate to open and permit the exit of the shock. The release of the catches is caused by the lug x^5 coming in contact with the projecting end of pivoted catch x^2 .

The bridge which supports the incoming stalks when the leaves of the table are open is in the present invention made in three folding pieces which practically cover the space to the vertical partition. Two members y, y' are pivoted at y^2 , and the other member y^3 is pivoted under the member y' on the stud y^6 and is connected with the pivoted arm y^4 by the crank arm y^7 and link y^8 , in the same manner as shown in my Patent No. 470,609. The member y^3 folds under member y' as the arm y^4 is moved by the vertical partition of the table, and the member y is connected with the member y' by slot and-pin connection y^5 so that the members y' and y^3 may fold under member y . This construction of bridge requires less space when folded.

The leaves of the table are in practice made about three inches less in diameter than the frame O' , so that there will be a space between the latter and the leaves of about one and one-half an inch. This will diminish the liability of obstructing the return of the leaves to closed position should any loose material be left after the shock has passed out.

In order to form a rolling interior surface to the base o , the top o' , and the top and bottom of the gate of the shock-forming frame, I provide an upper and a lower series of wheels or rollers z, z' , respectively, which are mounted on suitable journals z^2 . Those at top are located underneath the top o' , and the top of the gate while those at bottom are located on top of the base o and the bottom of the gate. These wheels or rollers are preferably inclined downwardly and inwardly so as to obstruct the downward passage of the shock as little as possible when the leaves are dropped. The object of these idle wheels or rollers is to form a rolling interior surface to relieve the carrying bars or packers of the heavy pressure that is incident to the stalks sliding against the inner sides of the beam, while the shock is being made inside.

What I claim as new, and desire to secure by Letters Patent, is—

1. In a harvesting machine, the combina-

tion of the main frame, the transversely movable shock forming frame suitably connected to the main frame, the transversely movable master-wheel frame supported in the main frame, a suitable connection between the wheel frame and the shock forming frame, and means for moving the wheel frame transversely; whereby the movement of the wheel frame will swing the shock forming frame transversely, substantially as set forth. 70

2. In a harvesting machine, the combination of the main frame, the shock-forming frame, links connecting said frames, and a transversely movable main wheel-frame connected with the links, substantially as set forth. 80

3. In a harvesting machine, the combination of the main frame, the shock-forming frame, links connecting said frames, a transversely movable main wheel-frame, and a pivoted arm extending from one of said links and adapted to be operated by the wheel-frame, substantially as set forth. 85

4. In a harvesting machine, the combination of the main frame, the shock-forming frame, links connecting said frames, a transversely movable main wheel-frame, an arm operated by the movement of said wheel-frame, and a slot and pin connection between the arm and one of said links, substantially as set forth. 90

5. In a harvesting machine, the combination of the vertically movable main frame, the transversely movable master-wheel supported in the main frame, the transversely movable frame supporting upright bars which have sliding connection with the wheel frame, means for moving the main frame vertically, and means for moving the wheel frame transversely; said transversely movable frame carrying the upright bars being adapted to move vertically with the main frame and transversely with the wheel frame, substantially as set forth. 100

6. In a harvesting machine, the combination of the main-frame, a transversely movable frame supporting upright bars, a cross-piece connecting the latter, means for guiding the movable frame and attachments transversely, the wheel-frame, means for adjusting the main frame vertically on the wheel frame, and means for moving the wheel frame transversely, substantially as set forth. 105

7. In a harvesting machine, the combination of the main frame, a transversely movable frame supporting upright bars, a cross-piece connecting the latter, transverse bars supported from the main-frame and providing a guide-way for said cross-piece, the main wheel frame, means for adjusting the main frame vertically on the wheel frame and means for shifting the wheel frame transversely, substantially as set forth. 110

8. In a harvesting machine, the combination of the main-frame, a transversely movable frame supporting upright bars, a cross-piece connecting the latter, arched braces ris-

- ing from the main-frame, parallel transverse bars connecting said braces at top and providing a guide-way for said cross-piece, the wheel-frame, means for adjusting the main frame vertically on the wheel frame, and means for shifting the wheel frame, substantially as set forth.
9. In a harvesting machine, the combination of the main-frame, the shock-forming frame, links connecting said frames, a transversely movable frame supporting upright bars, a pivoted arm connecting one of the bars and one of said links, the wheel-frame, and means for shifting the wheel frame transversely, substantially as set forth.
10. In a harvesting machine, the combination of the main-frame, braces rising from the main-frame, parallel bars connecting the braces, a transversely movable frame provided with upright bars, a cross-piece connecting the upright bars, and adapted to slide between said parallel bars, a lug projecting through the latter from the cross-piece, lugs on the movable frame, screw-rods passing through all of said lugs for moving said movable frame and one of the supporting wheels, and means for moving the main frame vertically on the wheel frame, substantially as set forth.
11. In a harvesting machine, the combination of the main-frame, the master-wheel frame on which it is yieldingly supported, the drive-shaft driven by the master-wheel and provided with a gear-wheel, another shaft geared to the drive-shaft a shiftable gear-wheel intermeshing with aforesaid gear-wheel, a bracket pivoted to the wheel-frame, and a support attached to the bracket and provided with slots or recesses to receive said shafts, substantially as set forth.
12. A harvester provided with an elevator chain, and a variable speed gearing for the chain, substantially as set forth.
13. A harvester provided with an elevator chain, and means for changing the speed of said chain, comprising a shiftable set of graduated cog-wheels, and a separate set of graduated cog-wheels adapted to be engaged by the before-mentioned cog-wheels, substantially as set forth.
14. In a harvester, the combination of an elevator chain, with means for changing its speed, comprising a shaft, a sliding or shiftable sleeve on the shaft, adapted to revolve therewith, a set of graduated cog-wheels on said sleeve, and a shaft carrying a separate set of graduated cog-wheels, with which the aforesaid cog-wheels intermesh, substantially as set forth.
15. In a harvester, the combination of an elevator chain, with means for changing its speed, comprising a shiftable set of cog-wheels, a lever for shifting them and a separate set of cog-wheels, adapted to be engaged by said cog-wheels, substantially as set forth.
16. In a harvester, the combination of elevator-chains, a changeable speed device for each chain, and connections between the separate speed-devices, whereby they may be operated simultaneously, substantially as set forth.
17. In a harvester, the combination of the main-frame, the shock-forming frame linked thereto, a bar pivoted to the main-frame, and a removable bolt connecting the bar to the shock-forming frame, substantially as set forth.
18. A shock table for harvesters provided with hinged leaves, in combination with horizontally operating pivoted catches formed with vertical body portions upon which they pivot and dependent cam-faced portions, springs for normally holding said catches in engagement with the leaves, and a base provided with means for operating the catches and allowing the leaves to fall, substantially as set forth.
19. A revolving shock table of a harvester, provided with hinged leaves, catches provided with pivots, bearings on the table in which the pivots turn, and trigger-arms projecting from the pivots, in combination with a base in which the table turns, provided with lugs for engaging the trigger-arms and releasing the catches from the leaves, substantially as set forth.
20. The combination of a revolving shock-forming table, the catches for the support of the leaves, with pendent cam faces and a lug for each catch on the base within which the revolving table turns; said lugs being placed in different planes on said base whereby each lug will act to trip its own catch only.
21. A shock table for a harvester provided with hinged leaves at the center, a bracket, a vertically pivoted button with cam faces in the latter constituting a catch for the leaves, and a device attached to said button for operating it, substantially as set forth.
22. A revolving shock table for a harvester provided with hinged leaves at the center, a bracket, a cam faced button pivoted in the latter and forming a catch for the leaves, a rod pivoted to the button and projecting through the frame of the table, and a spring for holding the rod normally projected, in combination with a base in which the table turns provided with a lug for engaging the rod, substantially as set forth.
23. A shock table for a harvester provided with a partition having a resiliently supported crowning-piece, substantially as set forth.
24. A shock table for a harvester provided with a partition having a movable crowning-piece with a slanting top, and a spring for resiliently supporting the crowning-piece, substantially as set forth.
25. A shock-forming device for harvesters provided with compressor segments, rock-shafts, arms projecting from the latter and supporting the segments, and means for operating the shafts, substantially as set forth.
26. A shock-forming device for harvesters

provided with a series of horizontal rock-shafts supported around the frame, vertically adjustable bearings for said shafts extending around the frame, and compressor segments carried by the shafts, substantially as set forth.

27. A shock-forming device for harvesters provided with a circular series of compressor segments supported around the frame, a suitable operating rod, a lever, and resilient connections between the latter and said rod, whereby the lever is caused to operate the segments, substantially as set forth.

28. In a shock forming device for harvesters, the combination with a suitable shocking frame, a series of horizontally arranged rock shafts journaled around said frame adjacent to the top and suitably geared to each other, a series of compressor segments carried by said rock shafts, and means for operating the rock shafts, substantially as set forth.

29. In a shock forming device for harvesters, the combination of a suitable shocking frame, a gate to said frame, a series of horizontal rock shafts arranged around said frame and gate, a series of compressor segments carried by said rock shafts, suitable gearing between the rock shafts, and means for operating them; the gearing between the ends of the rock shafts adjacent to the pivoted edge of the gate being arranged to disengage when the gate is opened and engage when it is closed, substantially as set forth.

30. The circular frame of the shock table of a harvester, in combination with hinged leaves, between whose edges and said frame spaces are left when the leaves are in normal position, substantially as set forth.

31. In combination with a revoluble shock table, the knotter and needle-shafts, a gear-wheel on the knotter-shaft provided with a

semi-circular flange and a semi-circular series of cogs or teeth and gearing for operating said gear-wheel at the proper time; a second gear-wheel adapted to intermesh with said series of cogs, a stop gear, with which said flange engages, and a wheel for positively actuating the table, actuated by said second gear-wheel, substantially as set forth.

32. In combination with a revoluble shock table provided with a series of teeth or cogs, the knotter and needle-shafts, a gear-wheel on the knotter-shaft, gearing for operating said gear-wheel, thrown into gear at the proper time by the table, and a gear-wheel operated through the medium of aforesaid gear-wheel and adapted to intermesh with the teeth or cogs of the table to positively actuate it, substantially as set forth.

33. A shock table for harvesters, provided with a partition, pivoted formers supported from said partition, and plates or extensions secured to said formers and projecting at right angles from the faces thereof and adapted to open the shock when it is dropped upon the ground and render it less liable to catch on the formers, substantially as set forth.

34. A shock table for harvesters, provided with a partition having an arm, a support for the partition also having an arm, and shock formers provided with extensions or plates pivotally supported upon said arms; said extensions or plates being adapted to open the shock and release it from the formers when it is dropped upon the ground, substantially as set forth.

EZRA E. WITTER.

Witnesses:

I. W. HOWARD,
A. H. GOODWIN.