



US00D780232S

(12) **United States Design Patent**
Saari et al.

(10) **Patent No.:** **US D780,232 S**

(45) **Date of Patent:** **** Feb. 28, 2017**

(54) **CAB OF A DRILLING VEHICLE**

(71) Applicant: **SANDVIK MINING AND CONSTRUCTION OY**, Tampere (FI)

(72) Inventors: **Jaakko Saari**, Tampere (FI); **Oki Ahokas**, Tampere (FI); **Jarmo Rantanen**, Julkujarvi (FI)

(73) Assignee: **SANDVIK MINING AND CONSTRUCTION OY**, Tampere (FI)

(**) Term: **15 Years**

(21) Appl. No.: **29/547,417**

D455,763	S	*	4/2002	Brandenburg, III	D15/28
D637,630	S	*	5/2011	Yamamoto	D15/30
D642,205	S	*	7/2011	Yamamoto	D15/30
D660,880	S	*	5/2012	Laugerette	D15/30
D660,881	S	*	5/2012	Bohme	D15/30
D671,566	S	*	11/2012	Fang	D15/30
D678,360	S	*	3/2013	Kozai	D15/30
D684,607	S	*	6/2013	Hagura	D15/30
D687,868	S	*	8/2013	Watson	D15/30
D720,370	S	*	12/2014	Carter	D15/30
D725,156	S	*	3/2015	Saari	D15/21
D726,780	S	*	4/2015	Saari	D15/21
D733,192	S	*	6/2015	Saari	D15/21
D749,148	S	*	2/2016	Darekar	D15/30
D751,123	S	*	3/2016	Kazakoff	D15/30
D762,248	S	*	7/2016	Steinhardt	D15/30
2009/0026803	A1	*	1/2009	Yano	B60J 1/04 296/190.1

(22) Filed: **Dec. 3, 2015**

(51) **LOC (10) Cl.** **15-03**
(52) **U.S. Cl.**
USPC **D15/30**

(58) **Field of Classification Search**
USPC D15/28, 30, 31, 22-26; D34/37;
180/89.11, 89.12, 89.13, 89.19, 900
CPC B66C 13/54; E02F 9/16; E02F 9/163;
E02F 9/06; B62D 33/0617; B62D
49/00-49/085; B62D 33/06-33/073; B60J
7/00; B60J 1/004; B60J 1/02; B60J 1/04;
B60J 5/0487
See application file for complete search history.

* cited by examiner

Primary Examiner — Mark Goodwin
(74) *Attorney, Agent, or Firm* — Corinne R. Gorski

(56) **References Cited**
U.S. PATENT DOCUMENTS

4,082,343 A * 4/1978 Hurt, II B62D 33/0604
180/89.12
D267,648 S * 1/1983 Baconet D15/30
D438,878 S * 3/2001 Brandenburg, III D15/30
D446,225 S * 8/2001 Brandenburg, III D15/30
D453,023 S * 1/2002 Kaneko D15/21

(57) **CLAIM**
The ornamental design for a cab of a drilling vehicle, as shown and described.

DESCRIPTION

FIG. 1 is a front perspective view of a cab of a drilling vehicle;
FIG. 2 is a rear perspective view thereof;
FIG. 3 is a side view thereof;
FIG. 4 is an opposite side view thereof;
FIG. 5 is a front view thereof;
FIG. 6 is a rear view thereof; and,
FIG. 7 is a top view thereof.
The broken lines in the figures are for illustrative purposes only and form no part of the claimed design.

1 Claim, 7 Drawing Sheets

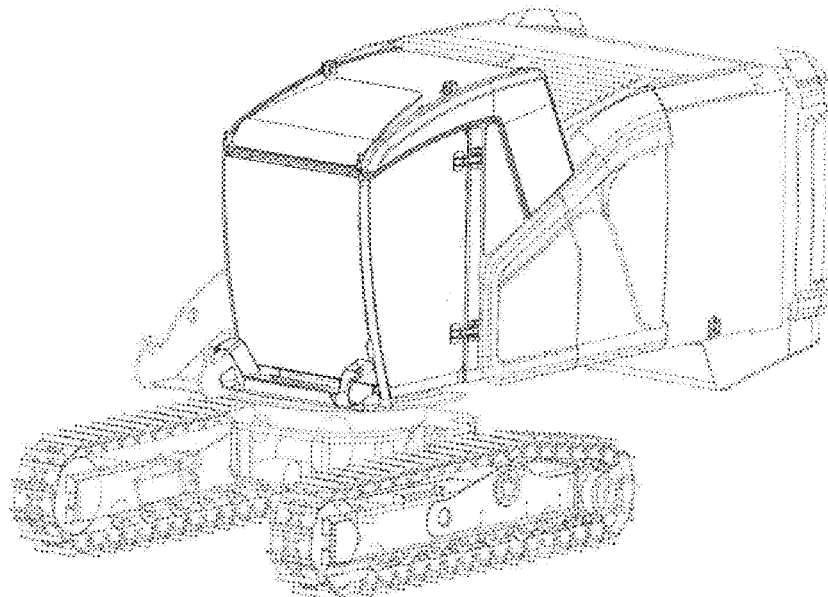

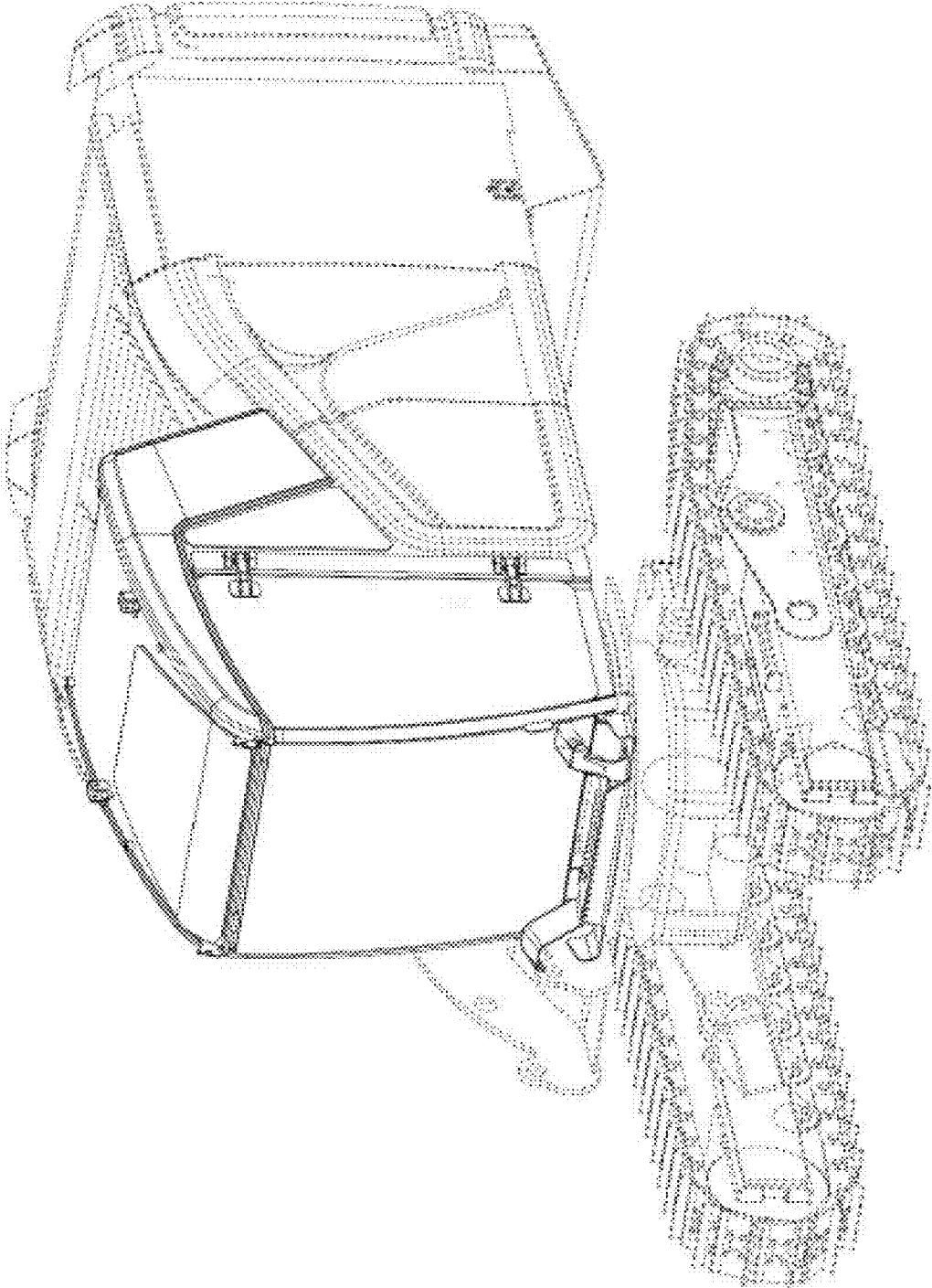

Fig. 1

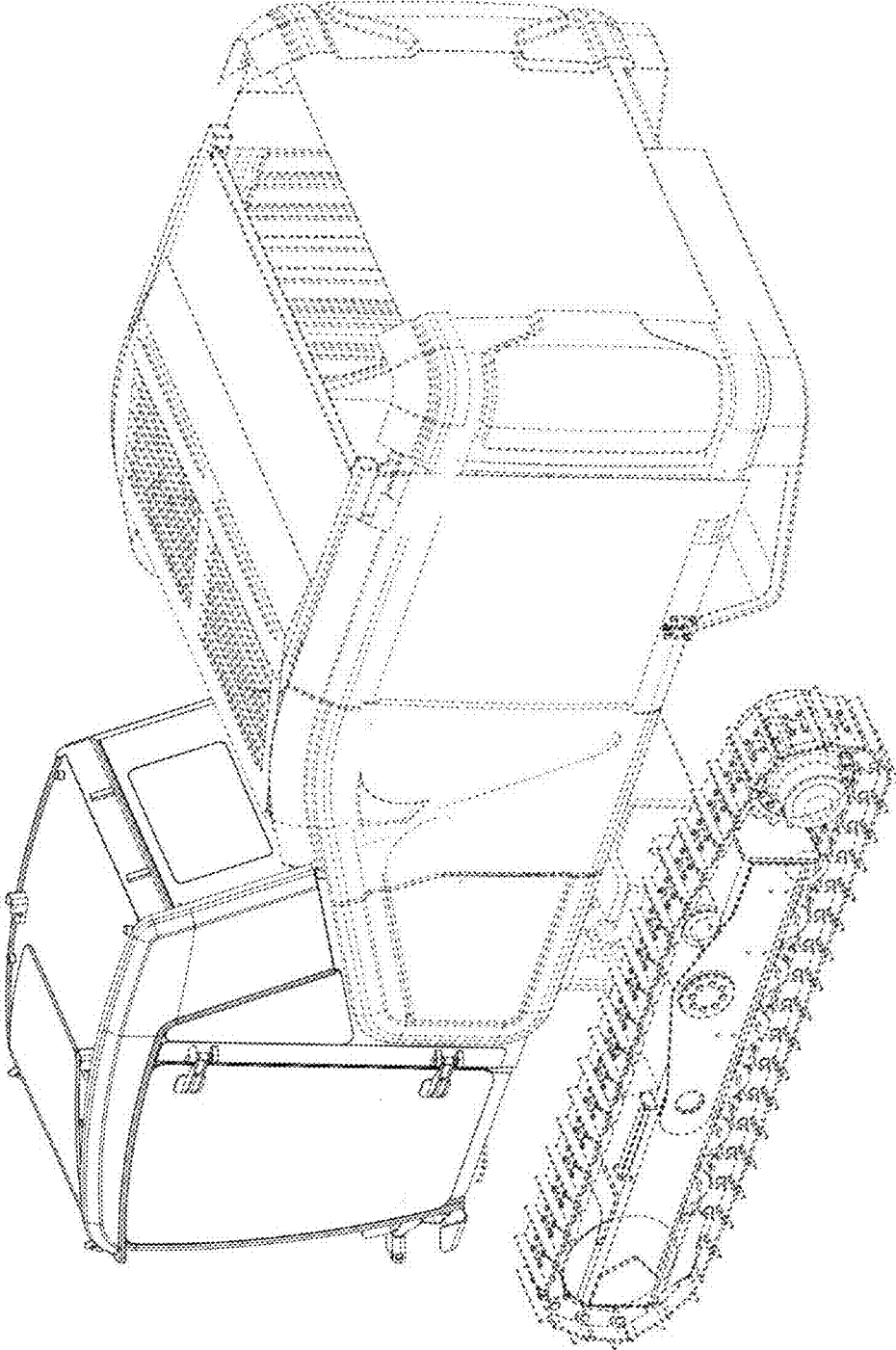

Fig. 2

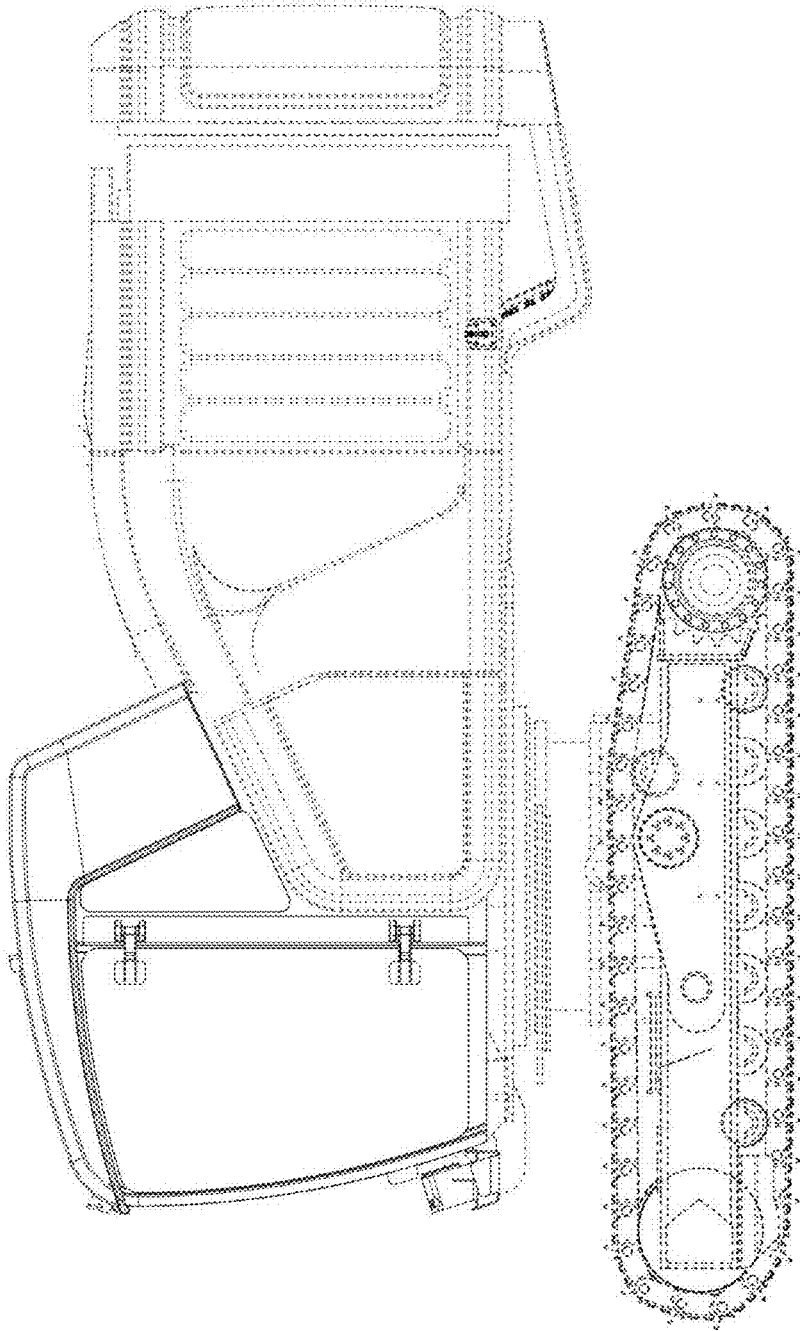

Fig. 3

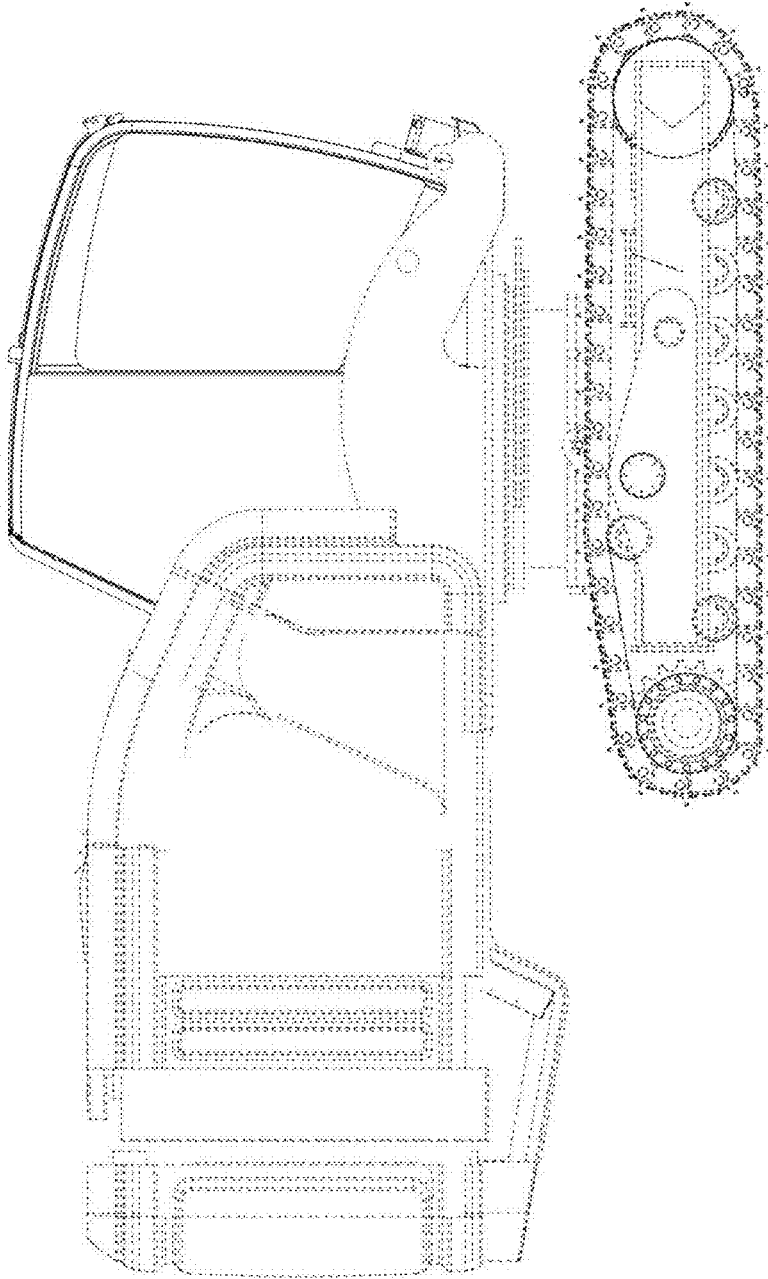

Fig. 4

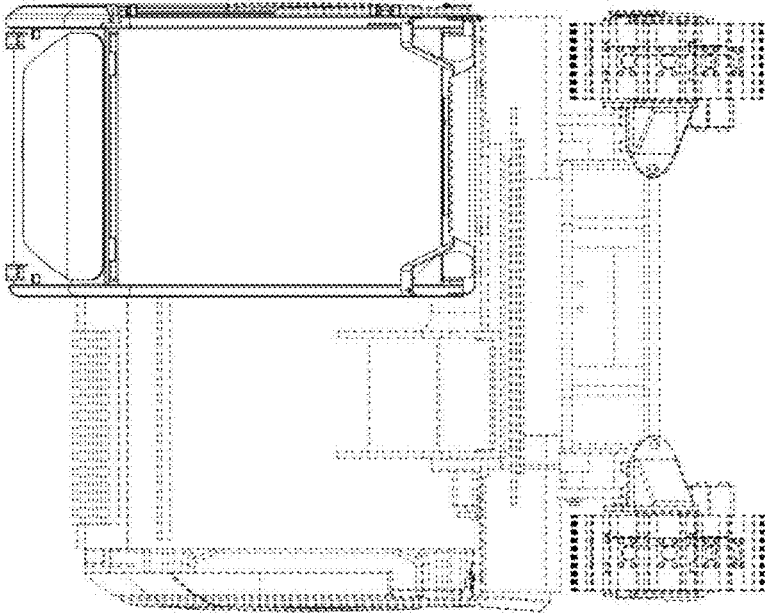

Fig. 5

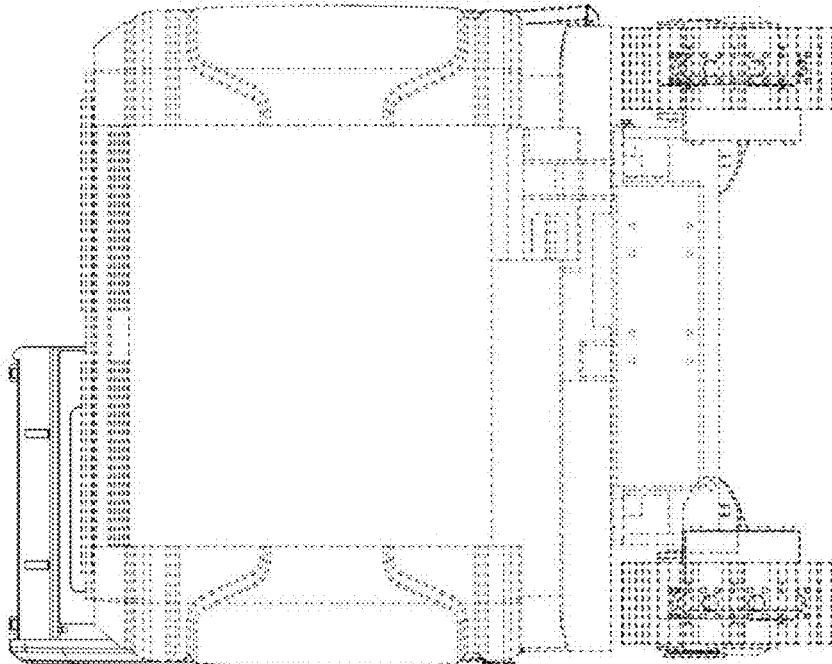

Fig. 6

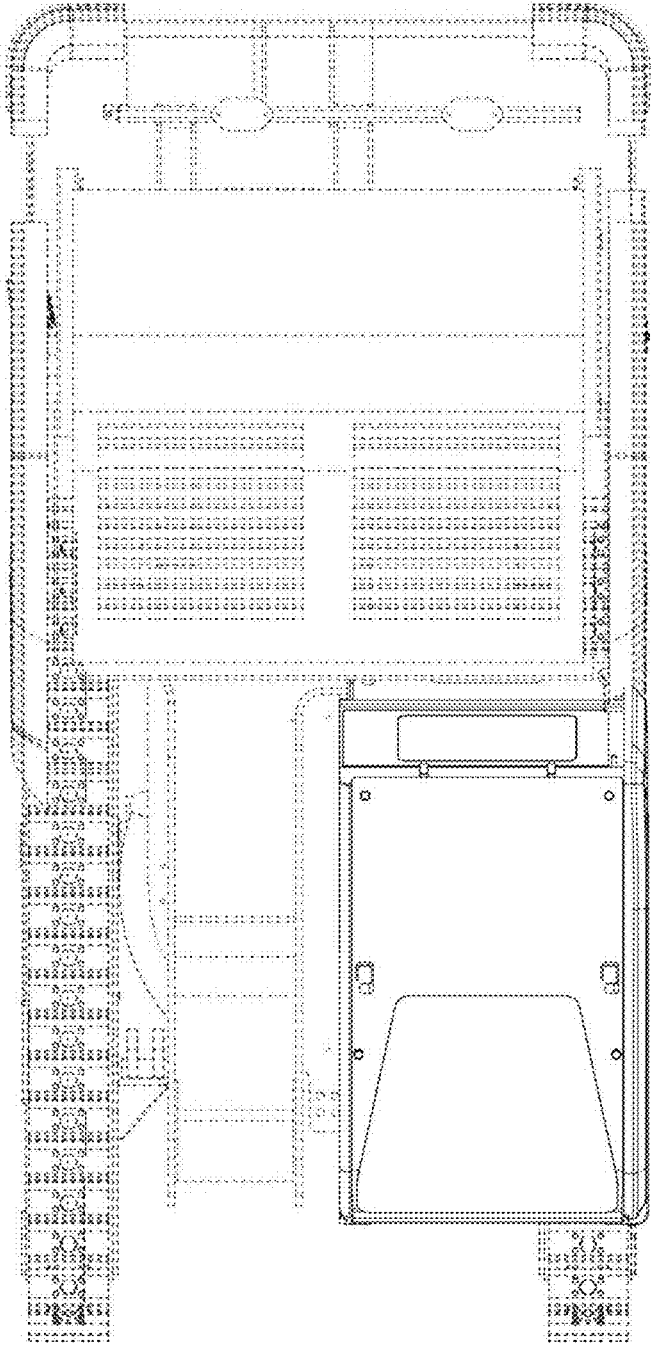

Fig. 7