

A. M. BELL.
 IRONING MACHINE.
 APPLICATION FILED MAY 20, 1907.

906,606.

Patented Dec. 15, 1908.

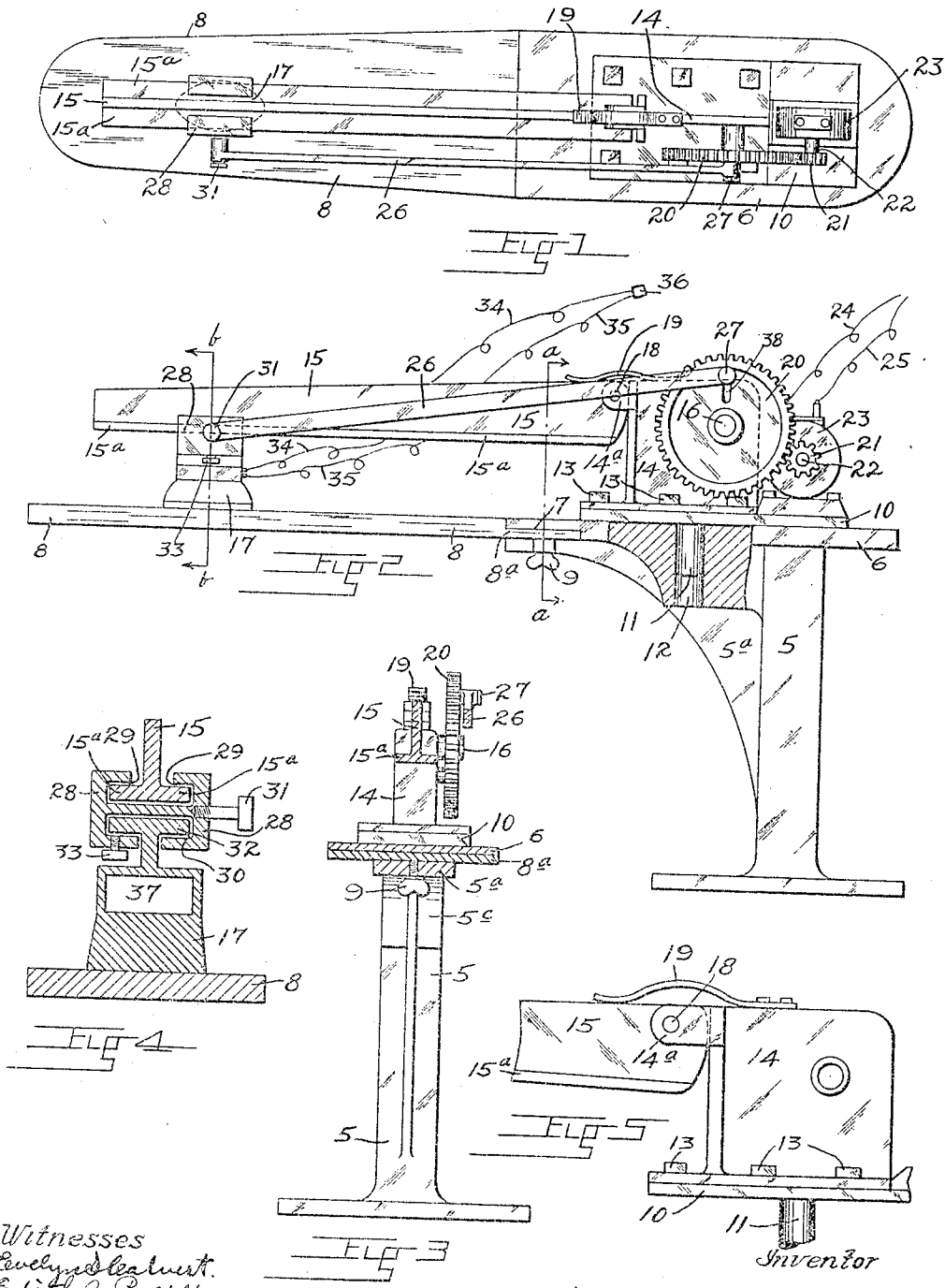

Witnesses
 Evelyn Belmont.
 Edith A. Beer.

Inventor
 Ann Maria Bell

UNITED STATES PATENT OFFICE.

ANN MARIE BELL, OF DENVER, COLORADO.

IRONING-MACHINE.

No. 906,606.

Specification of Letters Patent.

Patented Dec. 15, 1908.

Application filed May 20, 1907. Serial No. 374,733.

To all whom it may concern:

Be it known that I, ANN MARIA BELL, a citizen of the United States, residing in the city and county of Denver and State of Colorado, have invented certain new and useful Improvements in Ironing-Machines, of which the following is a specification.

My invention relates to improvements in ironing machines and more particularly to a class of ironing machines in which the smoothing-iron is heated by electricity and is electrically or mechanically reciprocated.

The objects of my invention are to provide an ironing machine which will be easily manipulated; one which will eliminate the greater part of the labor involved in ironing clothes; one in which the construction is such that the machine is adapted for ironing sheets and flat clothes or pieces of fabric and also skirts, sleeves, and all classes of garments and fabrics in which the ends or sides are connected; also one in which automatic means is provided for exerting pressure upon the smoothing-iron; and also one which is simple in its parts and which can be constructed at a reasonable cost.

I attain the foregoing objects by the construction outlined in the accompanying drawings in which similar numerals of reference indicate corresponding parts in all the figures and in which—

Figure 1 is a top plan view of my invention. Fig. 2 is a side elevation of my machine, partly sectional. Fig. 3 is a cross-section along line *a—*a** of Fig. 2. Fig. 4 is an enlarged cross-section along line *b—*b** of Fig. 2. Fig. 5 is an enlarged fragmental view of the hinged portion showing the inner end of the spring actuated guide-arm.

In more fully referring to the drawings 5 represents the supporting standard which may be constructed of cast iron or any other suitable metal or material and is provided with an inwardly extending brace or web 5^a and also with a longitudinally flanged portion or platform 6 preferably made integral with the standard; this platform is provided with a recess at the point (designated by 7) where the platform 6 extends inwardly the same distance as does the brace or web 5^a, forming a complete recess into which fits the end 8^a of the detachable ironing-board 8; and in its pre-

ferred construction the upper surface of the ironing-board is on a plane with the upper surface of the platform 6, as shown in Fig. 2. A thumb-screw 9 extends upwardly through the inwardly extending end of the brace or web 5^a and is adapted to engage the lower surface of the end 8^a of the ironing-board 8, which extends into the recess at 7, and to effectively maintain the ironing-board in its desired position though permitting of its removal by releasing the thumb-screw, made manifest in Figs. 2 and 3.

Another platform designated by 10 is placed in a revoluble manner upon the platform 6 which forms a part of or is attached to the standard 5, as illustrated; this platform 10 is secured to a depending axial pivot 11 which extends into an aperture 12, provided in the platform 6 and in the brace or web 5^a, as shown in Fig. 2. By this means the platform 10 is mounted so that it may readily and easily be revolved at will. Securely attached to the upper surface of the platform 10 by means of bolts 13 is a vertical and longitudinally disposed flanged upright rib 14 to which is pivoted the inverted T-shaped guide-arm 15, and to which is journaled the transversely disposed crank-shaft 16. The guide-arm 15 is adapted to support and guide the smoothing-iron 17 and is, as aforesaid, pivotally attached at its inner end to the lugs or ears 14^a of the upright rib 14 by means of the pin 18. A flat spring 19 is secured to the upper edge of the upright rib 14 and extends outwardly over the upper edge of the guide-arm 15 and is adapted to continually depress the guide-arm and in turn to maintain the smoothing-iron 17 in frictional contact with the garment or fabric desired to be ironed upon the surface of the ironing board 8. A spur-wheel 20 (having radial and peripheral cogs) is provided and attached to the crank-shaft 16 and the cogs thereon are adapted to mesh with the counterpart cogs on the pinion wheel 21, which is secured to the armature shaft 22 of an electric motor 23 (or to the shaft of other suitable revoluble means) which is preferably mounted upon the revolving platform 10 and may be connected with any convenient electrical circuit by means of conductor-wires 24 and 25. A connecting rod 26 is pivoted to the spur-wheel

20 by means of a wrist pin 27 and the opposite end thereof is connected with a sliding-head 28 to which is attached the smoothing-iron 17; this sliding-head is constructed of a metal block provided with longitudinal channels 29 and 30 and is provided with a laterally extending connecting-pin 31 by means of which it is pivotally attached to the connecting rod 26.

10 The smoothing-iron 17 is provided with a T-shaped head 32 adapted to fit into the channel 30 of the sliding-head 28 to which it may be securely attached by a cap-screw 33. It is preferably heated by electricity which is supplied, to any suitable heating apparatus contained therein, by means of the conductor wires 34 and 35 extending and attached to the plug 36 which may be inserted into any ordinary incandescent lamp socket. A recess or opening 37 may be formed in the smoothing-iron adapted to receive any suitable weight which will increase the pressure of the smoothing-iron upon the garment or fabric to be ironed when desired.

25 The sliding-head 28 is adapted to be slidably mounted on the extension flanges 15* of the T-shaped guide-arm 15, as the flanges extend through the channel 29 in the upper part of the sliding-head 28; a reciprocating movement is imparted to this sliding-head by means of the connecting-rod 26, gears 20 and 21 and motor 23. The length of the stroke of the sliding-head 28, and in turn of the smoothing-iron 17, may be increased or diminished by means of the connecting pin 27 which extends through a radial slot 38 in the spur-wheel 20 and may be radially adjusted therein. The smoothing-iron 17 may readily be removed from proximity to the ironing-board, for the purpose of adjusting or removing the garment or fabric being ironed, by swinging the guide-arm sidewise which is easily and readily accomplished in that the arm and the upright rib 14 (to which it is attached) are mounted upon the revolving platform 10. This construction also enables the operator to move the smoothing-iron in an arcuate path (as it relates to the ironing-board) by reciprocating it sidewise across the ironing-board and as this is done while the longitudinal reciprocation (imparted by the instrumentality of the connecting rod as aforesaid) is going on, the efficacy of my invention will readily be comprehended. When desiring to iron curtains, table-cloths or other garments or fabrics of large proportions a wide board may be substituted; and when desiring to iron sleeves and small articles it may be essential to use a sleeve board or board of less width and of different shape to provide convenient means for these varying articles; the ironing-board is made detachable and may readily be replaced by a board of any desired shape or proportion.

It will be observed that this machine is especially adapted for use in ironing skirts, sleeves and garments and articles of every kind and character, wherein the sides or ends of the cloth are joined, in that the guide-arm and the operating mechanism in connection therewith is above and out of the way of the ironing-board; and as there is but one end of the ironing-board attached to the supporting standard the opposite end is left free, facilitating the placement of such garments and articles in a position to be ironed on the board.

It is now obvious that the operation of my machine briefly stated will be as follows: Electrical current is conveyed to the motor 23 by means of the conductor-wires 24 and 25. A revolving movement is thus imparted to the armature shaft 22 to which is attached the pinion-wheel 21 meshing with the spur-wheel 20, thus imparting a reciprocating movement to the connecting rod 26, which in turn imparts a like movement longitudinally to the sliding-head 28 to which is attached the smoothing-iron 17; a reciprocating movement is given the smoothing-iron, sliding-head, etc., in an arcuate path sidewise, as aforesaid, by the operator. The guide-arm 15 is raised which raises the smoothing-iron, and the garment or fabric to be ironed can then be placed beneath it on the ironing-board 8.

The preferred construction will be generally as herein described and as shown in the drawings. I reserve the right, however, to make such variations and modifications as properly come within the scope of the protection prayed and to construct my new ironing machine in various sizes, of such material and in such a manner as will prove most practical and efficient for the uses and purposes for which it is adapted without departing from the spirit of the invention.

Having thus described the nature and objects of my invention what I claim and desire to secure by Letters Patent is—

1. In a device of the class named, the combination of a standard, an ironing-board detachably secured thereto at one of its extremities, a platform upon the standard rotatable about a vertical axis, a horizontal crank-shaft upon the platform, a motor upon the platform arranged to rotate the shaft, an arm mounted at its extremity upon the platform to move about a horizontal axis, a flat-iron slidable on the arm in engagement with the board and a pitman connecting the said iron with the crank on the shaft.

2. In a device of the class named, the combination of a standard, an ironing-board held thereon, an arm mounted upon the said standard to move about a vertical axis, a flat-iron slidable on the arm in engagement with the board, means on the standard to

impart a reciprocating movement to the iron, and automatic means to forcibly depress the free end of the arm.

3. In a device of the class named, the combination of a standard, an ironing-board held thereon, an arm mounted on the said standard to move about a vertical axis and to be pivotally movable in a vertical plane, a downwardly bearing spring in engagement with the arm, a flat-iron slidable on the lat-

ter in engagement with the board, and means on the standard to impart a reciprocating movement to the iron.

In testimony whereof I affix my signature in presence of two witnesses.

ANN MARIA BELL.

Witnesses:

EVELYN S. CALVERT,
EDITH A. BEERS.