

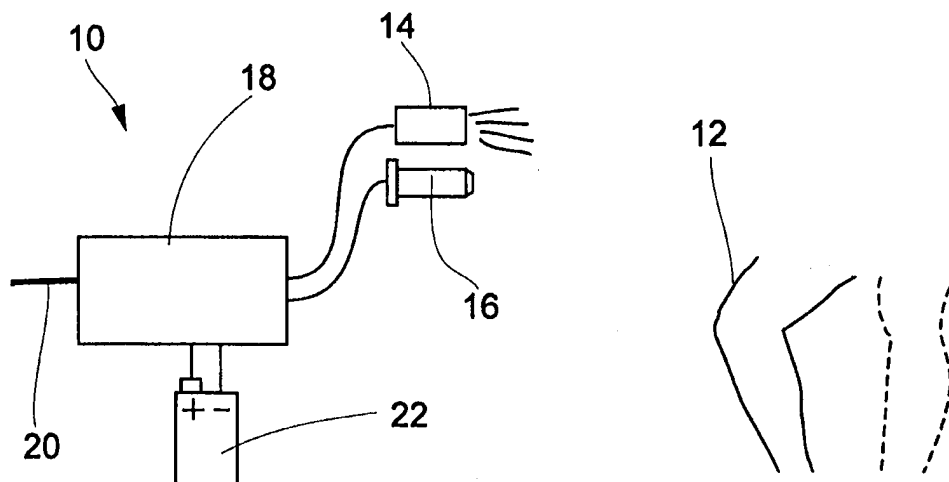

INTERNATIONAL APPLICATION PUBLISHED UNDER THE PATENT COOPERATION TREATY (PCT)

<p>(51) International Patent Classification ⁶ : G09B 19/00</p>	<p>A1</p>	<p>(11) International Publication Number: WO 98/36400</p> <p>(43) International Publication Date: 20 August 1998 (20.08.98)</p>
<p>(21) International Application Number: PCT/US98/02080</p> <p>(22) International Filing Date: 6 February 1998 (06.02.98)</p> <p>(30) Priority Data: 08/800,933 13 February 1997 (13.02.97) US</p> <p>(71) Applicant: ASSIST ADVANCED TECHNOLOGIES LTD. [IL/IL]; Tut Street 10, 71511 Lod (IL).</p> <p>(71) Applicant (for all designated States except CN JP KR): FRIEDMAN, Mark, M. [US/IL]; Alharizi 1, 43406 Raanana (IL).</p> <p>(72) Inventors: AVNI, Ofer; Gizu Street 1, 99745 Gizu (IL). SADOVSKY, Benjamin; 60948 Kibbutz Givat Brenner (IL).</p> <p>(74) Common Representative: FRIEDMAN, Mark, M.; c/o Castorina, Anthony, Suite 207, 2001 Jefferson Davis Highway, Arlington, VA 22202 (US).</p>		<p>(81) Designated States: CN, JP, KR, European patent (AT, BE, CH, DE, DK, ES, FI, FR, GB, GR, IE, IT, LU, MC, NL, PT, SE).</p> <p>Published <i>With international search report.</i></p>

(54) Title: SENSORS FOR MONITORING PERIODIC MOVEMENT OF A HUMAN SUBJECT



(57) Abstract

A sensor (10) for monitoring periodic movement of a human subject typically includes a transmitter (14) for transmitting a wireless signal towards a region of the subject and a receiver (16) for receiving a reflected part of the signal. A processor (18) analyzes the reflected part of the signal to identify periodic movement of the region of the human subject. The system may employ electromagnetic radiation or ultrasound, and may analyze variations in intensity, time of flight or Doppler shift. Other embodiments employ proximity sensors, transducers for sensing mechanical vibrations or sound, or a video camera and image processing.

FOR THE PURPOSES OF INFORMATION ONLY

Codes used to identify States party to the PCT on the front pages of pamphlets publishing international applications under the PCT.

AL	Albania	ES	Spain	LS	Lesotho	SI	Slovenia
AM	Armenia	FI	Finland	LT	Lithuania	SK	Slovakia
AT	Austria	FR	France	LU	Luxembourg	SN	Senegal
AU	Australia	GA	Gabon	LV	Latvia	SZ	Swaziland
AZ	Azerbaijan	GB	United Kingdom	MC	Monaco	TD	Chad
BA	Bosnia and Herzegovina	GE	Georgia	MD	Republic of Moldova	TG	Togo
BB	Barbados	GH	Ghana	MG	Madagascar	TJ	Tajikistan
BE	Belgium	GN	Guinea	MK	The former Yugoslav Republic of Macedonia	TM	Turkmenistan
BF	Burkina Faso	GR	Greece	ML	Mali	TR	Turkey
BG	Bulgaria	HU	Hungary	MN	Mongolia	TT	Trinidad and Tobago
BJ	Benin	IE	Ireland	MR	Mauritania	UA	Ukraine
BR	Brazil	IL	Israel	MW	Malawi	UG	Uganda
BY	Belarus	IS	Iceland	MX	Mexico	US	United States of America
CA	Canada	IT	Italy	NE	Niger	UZ	Uzbekistan
CF	Central African Republic	JP	Japan	NL	Netherlands	VN	Viet Nam
CG	Congo	KE	Kenya	NO	Norway	YU	Yugoslavia
CH	Switzerland	KG	Kyrgyzstan	NZ	New Zealand	ZW	Zimbabwe
CI	Côte d'Ivoire	KP	Democratic People's Republic of Korea	PL	Poland		
CM	Cameroon	KR	Republic of Korea	PT	Portugal		
CN	China	KZ	Kazakstan	RO	Romania		
CU	Cuba	LC	Saint Lucia	RU	Russian Federation		
CZ	Czech Republic	LI	Liechtenstein	SD	Sudan		
DE	Germany	LK	Sri Lanka	SE	Sweden		
DK	Denmark	LR	Liberia	SG	Singapore		
EE	Estonia						

SENSORS FOR MONITORING PERIODIC MOVEMENT
OF A HUMAN SUBJECT

FIELD AND BACKGROUND OF THE INVENTION

The present invention relates to devices for sensing human activity and, in particular, it concerns sensors for monitoring periodic movement of a human subject.

It is known to measure the level of activity of a subject using an exercise apparatus. For example, it is common for exercise bicycles and treadmills to be provided with a digital or analogue display which indicates the current level of effort being exerted by the subject. The measured level of activity can also be used as an input to a video game so as to provide an advantage to the subject when he exerts himself. This serves as an incentive to performance of the exercise activity.

The device used for measuring the level of activity for any given exercise apparatus is highly specific to the apparatus used. For example, in an exercise bicycle, the device typically measures the speed of rotation of a wheel. In a treadmill, the measurement is typically based on the speed of rotation of a roller in contact with the belt. As a result of the specialized nature of the measurement devices, any game system or other additional system associated with the activity level sensor must normally be designed or adapted specially for each exercise apparatus. This renders such systems very expensive.

An additional problem is posed by forms of exercise in which no specific exercise apparatus is used. PCT Publication No. WO 96/05766 describes a system in which a pressure sensitive pad is employed to measure the activity level of a subject running on-the-spot. The activity is calculated from a combination of the frequency of contact and the proportion of time spent airborne between steps. However, such a system is not readily adapted to other

exercise activities in which the feet do not move so regularly such as, for example, "sit-ups" and other floor exercises.

There is therefore a need for sensors which can be used with minimal adjustment for monitoring the activity level of a human subject performing a wide range of exercise activities, both with and without a particular exercise apparatus.

SUMMARY OF THE INVENTION

The present invention is a sensor for monitoring periodic movement of a human subject.

10 According to the teachings of the present invention there is provided, a sensor for monitoring periodic movement of a human subject, the sensor comprising: (a) a transmitter for transmitting a wireless signal towards a region of the human subject; (b) a receiver for receiving a part of the signal reflected from the region of the human subject; and (c) a processor, associated with the
15 receiver, for analyzing the reflected part of the signal to identify periodic movement of the region of the human subject.

According to a further feature of the present invention, the transmitter transmits an electromagnetic signal.

20 According to a further feature of the present invention, the electromagnetic signal is an infrared signal.

According to a further feature of the present invention, the processor identifies periodic movement of the region of the human subject by identifying periodic variations in the intensity of the reflected part of the signal.

25 According to a further feature of the present invention, the processor identifies periodic movement of the region of the human subject by identifying periodic variations in the Doppler shift of the reflected part of the signal.

According to a further feature of the present invention, the transmitter transmits a pressure-wave signal.

According to a further feature of the present invention, the pressure-wave signal is an ultrasound signal.

According to a further feature of the present invention, the processor identifies periodic movement of the region of the human subject by identifying
5 periodic variations in the intensity of the reflected part of the signal.

According to a further feature of the present invention, the processor identifies periodic movement of the region of the human subject by identifying periodic variations in the Doppler shift of the reflected part of the signal.

According to a further feature of the present invention, the processor
10 identifies periodic movement of the region of the human subject by identifying periodic variations in the time of flight of the reflected part of the signal.

There is also provided according to the teachings of the present invention, a sensor for monitoring periodic movement of a limb of a human subject, the sensor comprising: (a) a transmitter mounted on the limb for
15 transmitting a wireless signal; (b) a receiver mounted on the limb for receiving a part of the signal reflected from proximal surfaces; and (c) a processor, associated with the receiver, for analyzing the reflected part of the signal to identify periodic movement of the limb of the human subject.

There is also provided according to the teachings of the present
20 invention, a sensor for monitoring periodic movement of a limb of a human subject relative to a reference position, the sensor comprising: (a) a proximity sensor including a first element mounted on the limb of the human subject, and a second element mounted at the reference position, one of the first and second elements being responsive to proximity of the other of the elements to generate
25 a signal; and (b) a processor, associated with the one of the first and second elements and responsive to the signal, for identifying periodic movement of the limb of the human subject relative to the reference position.

According to a further feature of the present invention, the one of the elements includes a transmitter for transmitting an electromagnetic signal of a
30 given frequency, and the other of the elements includes a transponder

responsive to the given frequency to transmit a secondary electromagnetic signal.

According to a further feature of the present invention, the proximity sensor senses variations in capacitance resulting from proximity of the two
5 elements.

According to a further feature of the present invention, the one of the elements senses variations in magnetic field resulting from proximity of the other of the elements.

According to a further feature of the present invention, the other of the
10 elements includes a permanent magnet.

According to a further feature of the present invention, the other of the elements includes an electromagnet.

According to a further feature of the present invention, the one of the elements includes a Hall effect magnetic-field sensor.

15 There is also provided according to the teachings of the present invention, a method for identifying a level of exertion of a human subject performing an exercise activity, the method comprising: (a) generating range information relating to the distance from a reference point to a part of the human subject; (b) analyzing the range information to identify periodic
20 movement of the part of the human subject.

According to a further feature of the present invention, the range information is generated by a proximity sensor.

According to a further feature of the present invention, the proximity sensor includes a first element located at the reference point and a second
25 element attached to the part of the human subject.

According to a further feature of the present invention, the range information is generated by a range sensor.

According to a further feature of the present invention, the range information is generated by measurement of an intensity of a signal reflected by
30 the part of the human subject.

There is also provided according to the teachings of the present invention, a method for identifying a level of exertion of a human subject performing an exercise activity, the method comprising: (a) positioning a transducer so as to receive vibrations generated by movement of a part of the human subject; and (b) analyzing the received vibrations to identify periodic movement of the part of the human subject.

There is also provided according to the teachings of the present invention, a method for identifying a level of exertion of a human subject performing an exercise activity, the method comprising: (a) recording a sequence of video images of at least a part of the human subject; and (b) analyzing the sequence of video images to identify periodic movement within the sequence.

There is also provided according to the teachings of the present invention, an exercise-responsive game system comprising: (a) a sensor for producing an output indicative of a rate of periodic movement performed by a subject, the sensor including: (i) a transmitter for transmitting a wireless signal towards a region of the subject, (ii) a receiver for receiving a part of the signal reflected from the region of the subject, and (iii) a processor, associated with the receiver, for analyzing the reflected part of the signal to identify periodic movement of the region of the subject, the processor generating an output indicative of the rate of the periodic movement; and (b) a game device operatively connected to the sensor for implementing a computer game, the game device being responsive to the output to vary a parameter of the computer game.

According to a further feature of the present invention, the game device includes: (a) a display for displaying the computer game; and (b) an input device for allowing the subject to control an element of the computer game.

BRIEF DESCRIPTION OF THE DRAWINGS

The invention is herein described, by way of example only, with reference to the accompanying drawings, wherein:

FIG. 1 is a schematic representation of a first embodiment of a sensor, constructed and operative according to the teachings of the present invention, for monitoring periodic movement of a human subject;

FIG. 2 is a plot of transmitted and received signals according to a first implementation of the sensor of Figure 1;

FIG. 3 is a plot of transmitted and received signals according to a second implementation of the sensor of Figure 1;

FIGS. 4A and 4B are side views of the sensor of Figure 1, showing interchangeable mounting adapters;

FIGS. 5A are schematic side views illustrating possible positioning of the sensor of Figure 1 in the context of various exercise activities;

FIG. 6 is a schematic side view of an exercise-dependent game system, constructed and operative according to the teachings of the present invention, including the sensor of Figure 1;

FIG. 7 is a schematic perspective view of a second embodiment of a sensor, constructed and operative according to the teachings of the present invention, for monitoring periodic movement of a human subject, the sensor being adapted for attachment to a limb of the subject;

FIGS. 8A and 8B are schematic illustrations of the sensor of Figure 7 in use;

FIG. 9 is a schematic side view illustrating a third embodiment of a sensor, constructed and operative according to the teachings of the present invention, for monitoring periodic movement of a human subject;

FIG. 10 is a schematic side view illustrating a fourth embodiment of a sensor, constructed and operative according to the teachings of the present invention, for monitoring periodic movement of a human subject; and

FIGS. 11A-11C show a sequence of video images generated according to the method of a fifth embodiment of a sensor, constructed and operative according to the teachings of the present invention, for monitoring periodic movement of a human subject.

5 DESCRIPTION OF THE PREFERRED EMBODIMENTS

The present invention is a sensor for monitoring periodic movement of a human subject.

The principles and operation of a sensor according to the present invention may be better understood with reference to the drawings and the
10 accompanying description.

Referring now to the drawings, Figure 1 shows a first embodiment of a sensor, generally designated **10**, constructed and operative according to the teachings of the present invention, for monitoring periodic movement of a region of a human subject represented by leg **12**. Generally speaking, sensor **10**
15 has a transmitter **14** for transmitting a wireless signal towards leg **12**, and a receiver **16** for receiving a part of the signal reflected from leg **12**. A processor **18** is associated with receiver **16** for analyzing the reflected part of the signal to identify periodic movement of leg **12**. Processor **18** then typically outputs information about the periodic movement via output cable **20**. Power for sensor
20 **10** is preferably provided by a battery **22**.

It should be noted that the term "periodic" is used herein in the specification and claims to refer to any motion in which a given movement is performed repeatedly. The repetition is not necessarily, or even typically, exact. For example, the movements of a subject's limbs while running is considered,
25 for this purpose, periodic, although the exact form of the movement, its extent and its speed may vary considerably between successive steps. Furthermore, the periodic nature of the movement may be somewhat irregular. For this reason, it is a short-term average value of the frequency of periodic movement, taken

over a number of cycles, which is typically used as an indication of exerted effort.

Operation of a range of implementations of the present invention may be considered broadly as generating range information relating to the distance
5 from a reference point to a part of the human subject and then analyzing the range information to identify periodic movement of the part of the human subject. In this context, the term "range information" is defined broadly as any information related to the distance from the reference position to the part of the
10 subject's body, whether of a low resolution or even binary nature such as the output from a proximity sensor, or of a more precise quantitative nature. When the term "range sensor" is employed, it refers to a device of any kind designed to evaluate the distance between the sensor and some other object.

Turning now to Figures 2 and 3, it should be appreciated that sensor **10** may be implemented in a number of ways. Specifically, transmitter **14** and
15 receiver **16** may be designed to transmit and receive any of a number of different types of signals including, but not limited to, electromagnetic waves of various frequencies and pressure waves such as ultrasound. Similarly, processor **18** may employ various techniques and algorithms for identifying periodicity. For the purposes of illustration only, two particular examples will
20 be described in some detail. However, it will be clear to one ordinarily skilled in the art that the present invention may readily be implemented with a wide range of other combinations not explicitly described herein.

Figure 2 illustrates a transmitted signal **24** and a corresponding received signal **26** for a first implementation of sensor **10** based of infrared reflected
25 intensity. Transmitter **14** transmits a sequence of pulses of infrared radiation towards leg **12**, corresponding to signal **24**, and receiver **16** receives a reflected signal, corresponding to signal **26**. The frequency of pulses in transmitted signal **24** is preferably chosen to be significantly greater than the anticipated frequency of movement of the subject. Typically, at least ten pulses are
30 transmitted per second, and preferably at least about 30 per second. For

purposes of schematic representation, the frequency of pulses shown in Figure 2 has been reduced.

The exact intensity of the reflected signal depends on many variables such as the reflectivity of the surfaces within the field of view, their positions and their orientations. However, for a given position of sensor **10** directed towards a subject who is exercising, it is reasonable to assume that the only variable factors are a result of the movement of the subject. In particular, the most significant single variable factor in the reflected intensity is typically the distance between the reflecting surface and the receiver. As a result, periodic movement towards and away from the sensor results in varying intensities of the reflected pulses, as shown.

In the case of electromagnetic radiation, any time lag between transmission of the transmitted signal and reception of the reflected signal is typically short compared to the length of the pulses. This allows simple selection of the parts of the received signal corresponding to each transmitted pulse. Processor **18** then performs basic signal processing on the received signal to identify periodicity. This may be achieved by use of a wide range of algorithms. By way of example only, one possible algorithm identifies crossings of an upper-third value and a lower-third value. Specifically, the algorithm identifies the maximum and minimum values of reflected pulse intensities in the reflected signal occurring within a given time period. The minimum-to-maximum range is then divided into three equal portions thereby defining an upper-third value and a lower-third value. Periodicity can then be identified as a sequence of: an upward crossing of the upper-third value; a downward crossing of the upper-third value; a downward crossing of the lower-third value; and an upward crossing of the lower-third value. The period of the movement is then identified as the time between two equivalent crossings, and the frequency is the reciprocal of that measurement. As mentioned earlier, processor **18** preferably averages a sequence of frequency measurements to provide a value representative of the level of effort being exerted.

It should be noted that the above algorithm, as well as a range of other algorithms, may be performed on successive discrete sequences of values, or on a dynamically changing set of values falling within a moving time-window. In either case, the number of values processed for each reading preferably
5 corresponds to between about three and about ten seconds, thereby ensuring that the readings include a number of repetitions for most common exercise activities.

It should also be noted that the required algorithms, and hence processor
18, may be implemented by either digital or analogue technology, and by either
10 purpose designed hardware or a suitably programmed general purpose processor.

As mentioned earlier, system 10 may also be implemented with pressure waves, such as ultrasound. In principle, the intensity-measurement based analysis described above with reference to Figure 2 may also be applied to an
15 ultrasound implementation. However, problems of ambient noise would complicate such an implementation. It is therefore usually advantageous to replace, or supplement, the intensity-measurement based analysis with one based on time-of-flight and/or Doppler shift. Ultrasound time-of-flight ranging is based on measurements of the delay between transmission of a pulse and
20 reception of the corresponding reflected pulse. Since this delay corresponds to the time taken for the pressure waves to travel twice the sensor-to-object distance, the delay time is a direct indication of the distance between the sensor and the object. A Doppler shift approach is based on the variations in frequency of the reflected signal caused by the velocity of the reflecting surface relative to
25 the sensor. Parenthetically, it is noted that Doppler shift and time-of-flight techniques may, in some cases, be usable also with embodiments employing electromagnetic radiation signals.

Figure 3 illustrates a transmitted signal 30 and a corresponding received signal 32 for a second implementation of sensor 10 based of ultrasound Doppler
30 effects. Transmitter 14 transmits a sequence of pulses of ultrasound towards leg

12, corresponding to signal 30, and receiver 16 receives a reflected signal, corresponding to signal 26. Here too, the frequency of pulses in transmitted signal 30 is preferably chosen to be significantly greater than the anticipated frequency of movement of the subject. Furthermore, the frequency of
5 ultrasound employed is typically much higher than the frequency of the pulses and each pulse contains many ultrasound vibrations. For the purpose of schematic representation, these relative frequencies have been distorted in Figure 3.

Transmitted signal 30 typically contains pulses of a given constant
10 frequency ν_0 . Received signal 32 contains corresponding pulses each of which is delayed by a certain time-of-flight delay relative to the transmitted pulse, and may be slightly frequency-shifted relative to the transmitted ν_0 frequency. Thus, by way of schematic example, received signal 32 is shown with a first pulse with upwardly-shifted or increased frequency, a second pulse with
15 downwardly-shifted or lower frequency, and a third pulse approximating to the transmitted frequency. It should be noted that these effects are shown here in an exaggerated manner, and that transitions between opposite frequency shifts will typically take place over a span of number of pulses.

Since the degree of frequency shift is proportional to the velocity of the
20 reflecting surface relative to, and aligned with, the sensor, periodicity of the frequency shift variations corresponds to periodic reciprocating movement. Thus, periodic movement of a subject may be identified and its frequency measured in a manner similar to that described above.

Turning now to Figures 4A and 4B, it is a particular feature of most
25 preferred embodiments of the present invention that sensor 10 is not limited to use with any specific type of exercise apparatus. Furthermore, it is preferably suitable for use with a wide range of exercise activities which do not require specialized apparatus. To this end, sensor 10 is preferably implemented as a compact unit 34 with an attachment bracket 36 suitable (Figure 4A) for
30 attachment to a wide variety of exercise apparatuses and other common objects

in the vicinity of the subject. Attachment bracket 36 may employ any conventional attachment including, but not limited to, flexible straps with or without Velcro[®], suction cups, magnets, and clips of various types. Typically, a spring clip may provide the most versatile attachment bracket 36, as shown.

5 For certain applications, sensor unit 34 may be used free-standing on a floor or other surface. For this purpose, sensor unit 34 may be provided with one or more leg 38. Legs 38 may be adjustable to change the inclination, and hence field of view, of sensor unit 34. In a preferred embodiment, legs 38 and a number of alternative attachment brackets 36 are provided for interchangeably
10 attaching to and removing from sensor unit 34 depending on the particular application required.

Figures 5A-5E illustrate the positioning of sensor 10 for use in a range of exercise activities. Specifically, Figures 5A-5C show sensor unit 34 attached to an exercise bicycle 40, a treadmill 42 and a rowing machine 44, respectively.
15 Figures 5D and 5E show sensor unit 34 mounted on the floor for monitoring a subject 46 performing sit-ups and jogging on-the-spot, respectively.

In this context, it should be noted that sensor 10 does not generally require precise positioning or alignment. For example, all embodiments in which range information is used can function properly in a wide range of
20 positions. If positioned such that a part of the body is within the field of view at all times, the sensor will detect any periodicity in the changes of the position of that part of the body. If positioned such that a part of the body enters and leaves the field of view, the alternation of views of the body part and a more distant background will also provide the required periodicity. Only in the case of a
25 Doppler-based system is it important to avoid arrangements in which the primary movement is purely transverse to the viewing direction.

As mentioned earlier, the sensors of the present invention may be used in any situation in which an indication of the degree of exertion of a human subject is desired. However, the sensors are considered to be of particular
30 significance in the context of exercise-dependent computer games. The phrase

“exercise-dependent computer game” is used herein in the specification and claims to refer to any electronic implementation of a game in which some aspect of the game or its presentation changes in response to an indication of exertion, typically by the player. Such games include, but are not limited to, video games of all sorts such as vehicle simulators, interactive combat games, and games of the type commonly associated with the tradename Pacman[®], games of chance, and thought games which progress in discrete steps, commonly called “moves”, selected by the player from a finite set of possible moves on the basis of analysis. Examples of the latter sort include a wide range of board games and card games such as chess, draughts, othello, backgammon, scrabble and bridge, as well as games in which a recollection of the previous progression of a game gives the player an advantage, such as adventure-type computer games. Techniques for rendering thought games and games of chance “exercise-dependent” are addressed in a co-pending application entitled “System and Method for Exercise-Dependent Thought-Game” filed the same day as this application.

Figure 6 illustrates the typical components of an exercise-dependent game system, generally designated **50**, constructed and operative according to the teachings of the present invention, employing sensor unit **34**. System **50** includes a display **52**, an input device **54**, and a processor **56**, typically implemented as a microcomputer. Display **52**, input device **54**, and processor **56** may be implemented as any conventional components, and some or all of them may be combined in any combination within a single combination “game unit”.

Turning now to a second embodiment of the present invention, Figures 7, 8A and 8B show a sensor, generally designated **60**, constructed and operative according to the teachings of the present invention, for monitoring periodic movement of a limb **62** of a human subject. Generally speaking, sensor **60** is similar to sensor **10**, both in structure and function, and may be understood by analogy to the above description. Sensor **60** differs from sensor **10** primarily in

that it is adapted for mounting on the limb of a subject. It follows that, technically speaking, sensor 60 monitors periodic movement of the surroundings relative to the subject.

Specifically, sensor 60 is provided with means 64 for attaching it to a limb of the subject. This attachment means may take any form conventionally used for attachment to the body. Typically, the most convenient form is a flexible cuff provided with Velcro[®], as shown. Output from sensor 60 may be through direct connection via electrical wires. However, for convenience of use, sensor 60 preferable contains elements of a wireless communications link, typically of radio frequency, for transmission of the output to a remote receiver unit 66.

Figures 8A and 8B illustrate sensor 60 in use. Clearly, most periodic movement will result in periodic variations in both the distance and velocity of sensor 60 relative to proximal surfaces, represented here by distances d_1 and d_2 . As a result, sensor 60 can identify and monitor periodic movement in the same manner as described in relation to sensor 10, above. Again, the positioning of sensor 60 is generally not critical. The sensor is typically designed to have a maximum range of between about 1 and about 2 meters. This is usually sufficient to ensure reception of signals reflected from some surfaces proximal to the subject.

Turning now to Figures 9-11, these illustrate a further three embodiments of the sensor of the present invention employing different operational principles from the embodiments described thus far. Figure 9 shows a sensor, generally designated 70, constructed and operative according to the teachings of the present invention, which employs a two-element proximity sensor to monitor periodic movement of a limb 72 of a human subject relative to a reference position.

Sensor 70 includes a first proximity sensor element 74 mounted on limb 72, and a second proximity sensor element 76 mounted at the reference position. Second element 76 is responsive to proximity of first element 74

within a given approximate range R to generate a signal. A processor (not shown separately) is associated with second element 76 so as to receive the signal. The processor then processes the signal in a manner analogous to that described above to identify periodic movement of limb 72 of the human subject
5 relative to the reference position.

It should be noted that elements 74 and 76 may be reversed such that element 76 is mounted on limb 72 and element 74 is mounted at the reference position. In this case, element 76 may be provided with components of a wireless communications link analogous to that of the embodiment of Figure 7.

10 It will be clear to one ordinarily skilled in the art that sensor 70 may be implemented using a range of different technologies known for proximity sensor applications. In one particular implementation, second element 76 may include a transmitter for transmitting an electromagnetic signal of a given frequency, and first element 74 includes a transponder responsive to the given
15 frequency to transmit a secondary electromagnetic signal. In another implementation, second element 76 senses variations in capacitance resulting from proximity of a conductive first element 74. In a further alternative implementation, second element 76 senses variations in magnetic field resulting from proximity of first element 74. In this latter case, first element 74 may
20 include either a permanent magnet or an electromagnet. Second element 76 may include a Hall effect magnetic-field sensor.

Turning now to Figure 10, there is shown a sensor, generally designated 80, constructed and operative according to the teachings of the present invention, for identifying a level of exertion of a human subject performing an
25 exercise activity by measuring vibration generated by movement of the subject. Sensor 80 employs a transducer 82 positioned so as to receive vibrations generated by movement of at least a part of the human subject. By way of example, transducer 82 is shown attached to the base of a treadmill apparatus 84. However, sensor 82 may alternatively be positioned for receiving sound
30 vibrations caused directly by movement of the subject's body. The processing

and other features of sensor 80 may be understood by analogy to the sensors described above.

Finally, Figures 11A-C illustrate the operational principles of a further embodiment of a sensor, constructed and operative according to the teachings
5 of the present invention, in which a video camera is used to record a sequence of video images of at least a part of the human subject. A processor is provided for processing the sequence of video images by conventional image processing techniques and then analyzing them to identify periodic movement within the sequence of images.

10 A range of conventional image processing algorithms may be used. By way of example only, difference mapping and edge recognition algorithms may be used to generate an outline of the image elements which move between frames. A region containing moving image elements can then be defined, and algorithms similar to those described above can be employed to identify
15 periodic variations in the dimensions of this region. Figures 11A-C represent a sequence of video images of a subject exercising on an exercise bicycle. The region containing the moving image elements is indicated in each image by a dashed line.

It will be appreciated that the above descriptions are intended only to
20 serve as examples, and that many other embodiments are possible within the spirit and the scope of the present invention.

WHAT IS CLAIMED IS:

1. A sensor for monitoring periodic movement of a human subject, the sensor comprising:

- (a) a transmitter for transmitting a wireless signal towards a region of the human subject;
- (b) a receiver for receiving a part of said signal reflected from said region of the human subject; and
- (c) a processor, associated with said receiver, for analyzing said reflected part of said signal to identify periodic movement of said region of the human subject.

2. The sensor of claim 1, wherein said transmitter transmits an electromagnetic signal.

3. The sensor of claim 2, wherein said electromagnetic signal is an infrared signal.

4. The sensor of claim 2, wherein said processor identifies periodic movement of said region of the human subject by identifying periodic variations in the intensity of said reflected part of said signal.

5. The sensor of claim 2, wherein said processor identifies periodic movement of said region of the human subject by identifying periodic variations in the Doppler shift of said reflected part of said signal.

6. The sensor of claim 1, wherein said transmitter transmits a pressure-wave signal.

7. The sensor of claim 6, wherein said pressure-wave signal is an ultrasound signal.

8. The sensor of claim 6, wherein said processor identifies periodic movement of said region of the human subject by identifying periodic variations in the intensity of said reflected part of said signal.

9. The sensor of claim 6, wherein said processor identifies periodic movement of said region of the human subject by identifying periodic variations in the Doppler shift of said reflected part of said signal.

10. The sensor of claim 6, wherein said processor identifies periodic movement of said region of the human subject by identifying periodic variations in the time of flight of said reflected part of said signal.

11. A sensor for monitoring periodic movement of a limb of a human subject, the sensor comprising:

- (a) a transmitter mounted on the limb for transmitting a wireless signal;
- (b) a receiver mounted on the limb for receiving a part of said signal reflected from proximal surfaces; and
- (c) a processor, associated with said receiver, for analyzing said reflected part of said signal to identify periodic movement of the limb of the human subject.

12. A sensor for monitoring periodic movement of a limb of a human subject relative to a reference position, the sensor comprising:

- (a) a proximity sensor including a first element mounted on the limb of the human subject, and a second element mounted at the reference position, one of said first and second elements being

responsive to proximity of the other of said elements to generate a signal; and

- (b) a processor, associated with said one of said first and second elements and responsive to said signal, for identifying periodic movement of the limb of the human subject relative to the reference position.

13. The sensor of claim 12, wherein said one of said elements includes a transmitter for transmitting an electromagnetic signal of a given frequency, and wherein said other of said elements includes a transponder responsive to said given frequency to transmit a secondary electromagnetic signal.

14. The sensor of claim 12, wherein said proximity sensor senses variations in capacitance resulting from proximity of said two elements.

15. The sensor of claim 12, wherein said one of said elements senses variations in magnetic field resulting from proximity of said other of said elements.

16. The sensor of claim 15, wherein said other of said elements includes a permanent magnet.

17. The sensor of claim 15, wherein said other of said elements includes an electromagnet.

18. The sensor of claim 15, wherein said one of said elements includes a Hall effect magnetic-field sensor.

19. A method for identifying a level of exertion of a human subject performing an exercise activity, the method comprising:

- (a) generating range information relating to the distance from a reference point to a part of the human subject;
- (b) analyzing said range information to identify periodic movement of said part of the human subject.

20. The method of claim 19, wherein said range information is generated by a proximity sensor.

21. The method of claim 20, wherein said proximity sensor includes a first element located at said reference point and a second element attached to said part of the human subject.

22. The method of claim 19, wherein said range information is generated by a range sensor.

23. The method of claim 19, wherein said range information is generated by measurement of an intensity of a signal reflected by said part of the human subject.

24. A method for identifying a level of exertion of a human subject performing an exercise activity, the method comprising:

- (a) positioning a transducer so as to receive vibrations generated by movement of a part of the human subject; and
- (b) analyzing said received vibrations to identify periodic movement of said part of the human subject.

25. A method for identifying a level of exertion of a human subject performing an exercise activity, the method comprising:

- (a) recording a sequence of video images of at least a part of the human subject; and
- (b) analyzing said sequence of video images to identify periodic movement within said sequence.

26. An exercise-responsive game system comprising:

- (a) a sensor for producing an output indicative of a rate of periodic movement performed by a subject, the sensor including:
 - (i) a transmitter for transmitting a wireless signal towards a region of the subject,
 - (ii) a receiver for receiving a part of said signal reflected from said region of the subject, and
 - (iii) a processor, associated with said receiver, for analyzing said reflected part of said signal to identify periodic movement of said region of the subject, said processor generating an output indicative of the rate of said periodic movement; and
- (b) a game device operatively connected to said sensor for implementing a computer game, said game device being responsive to said output to vary a parameter of said computer game.

27. The system of claim 26, wherein said game device includes:

- (a) a display for displaying said computer game; and
- (b) an input device for allowing the subject to control an element of said computer game.

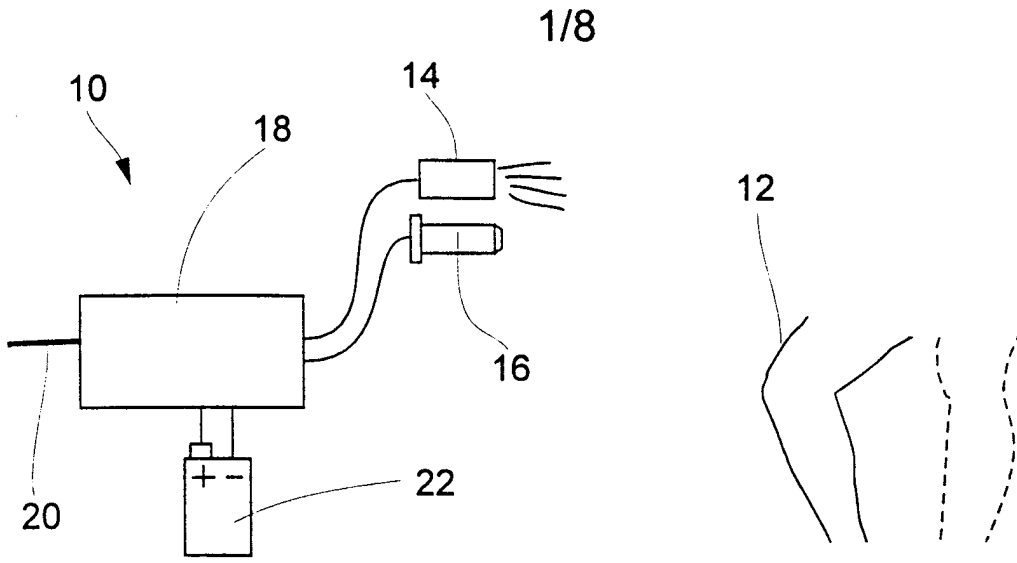

Fig. 1

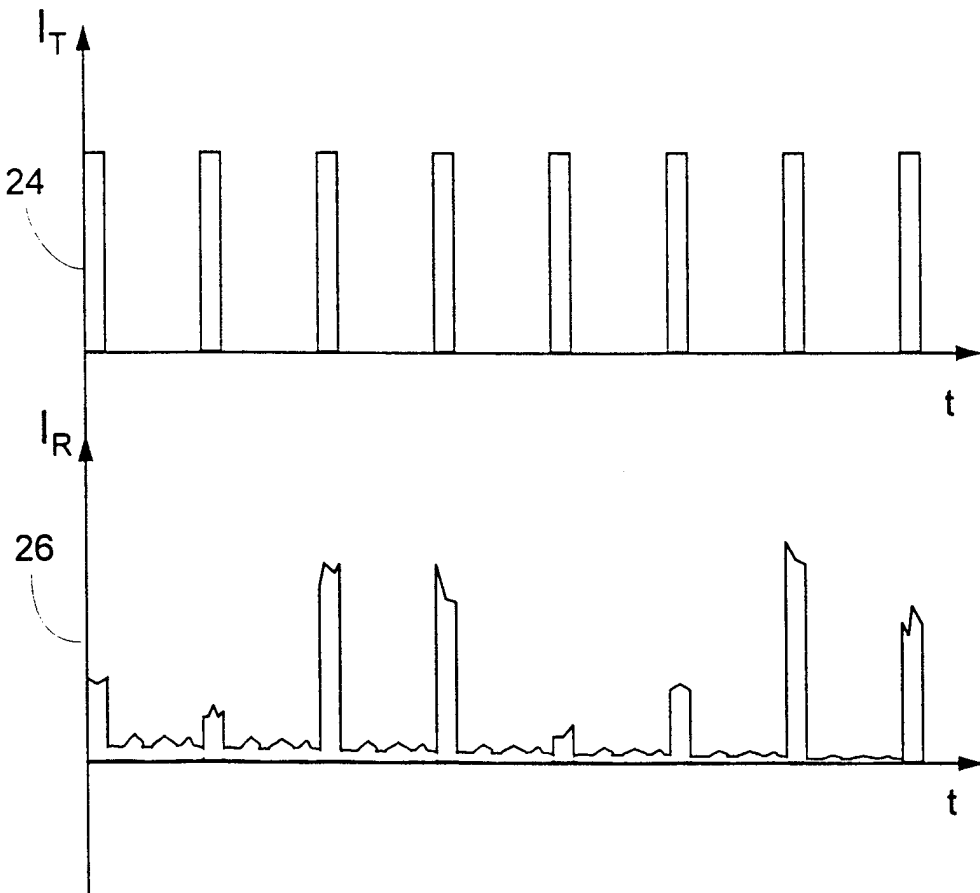

Fig.2

2/8

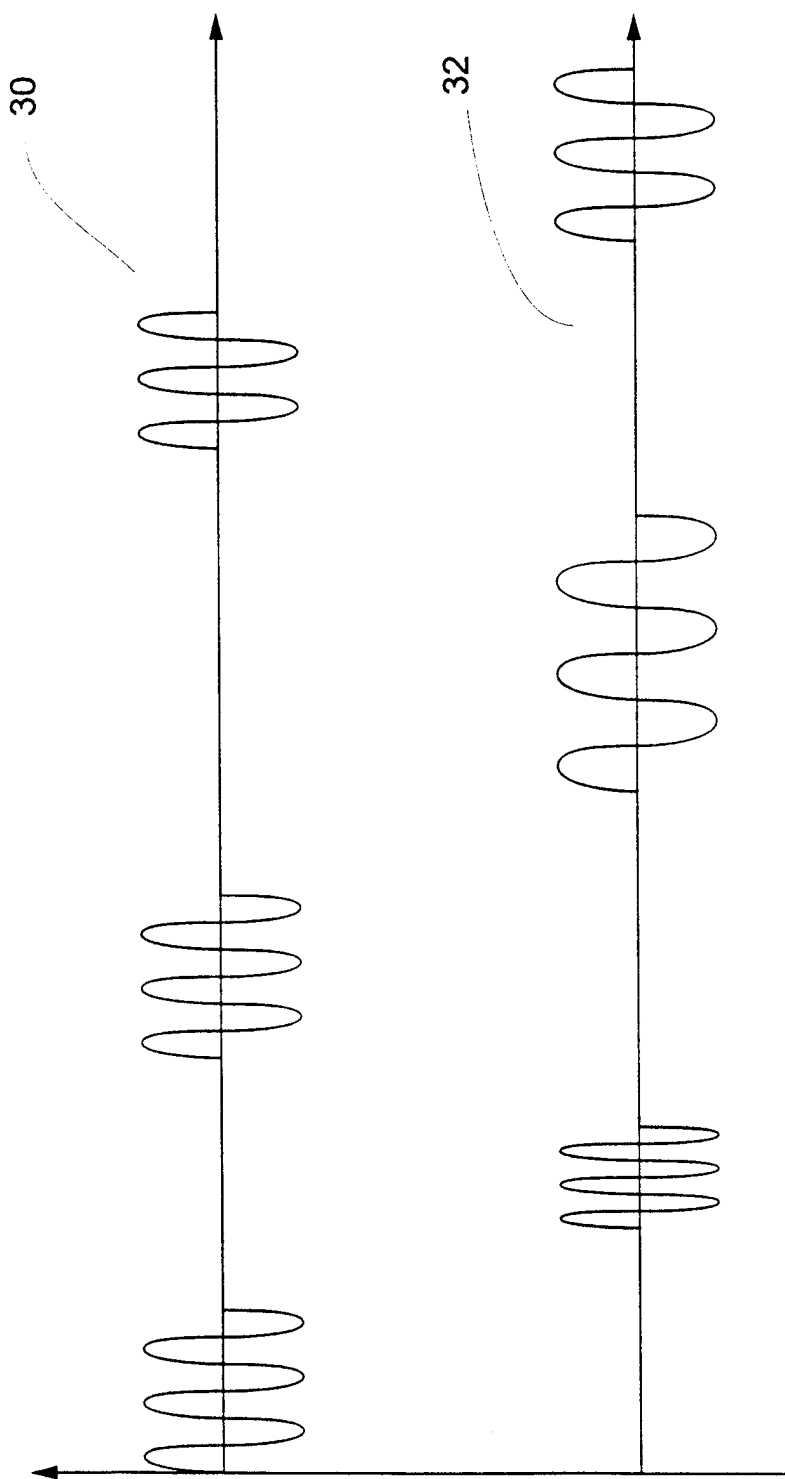

Fig.3

3/8

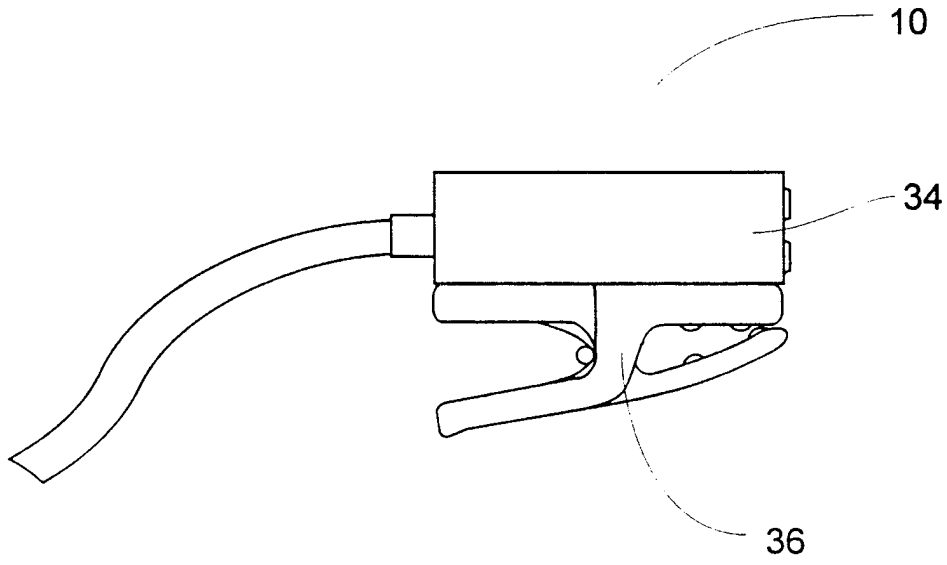

Fig.4a

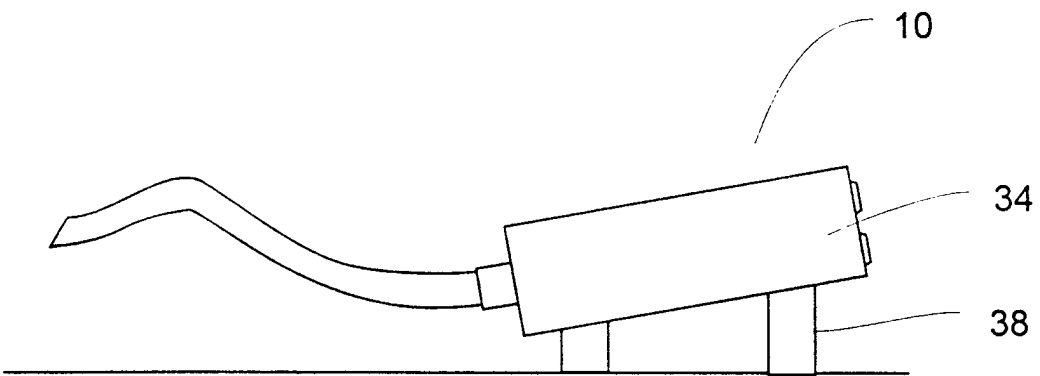

Fig.4b

4/8

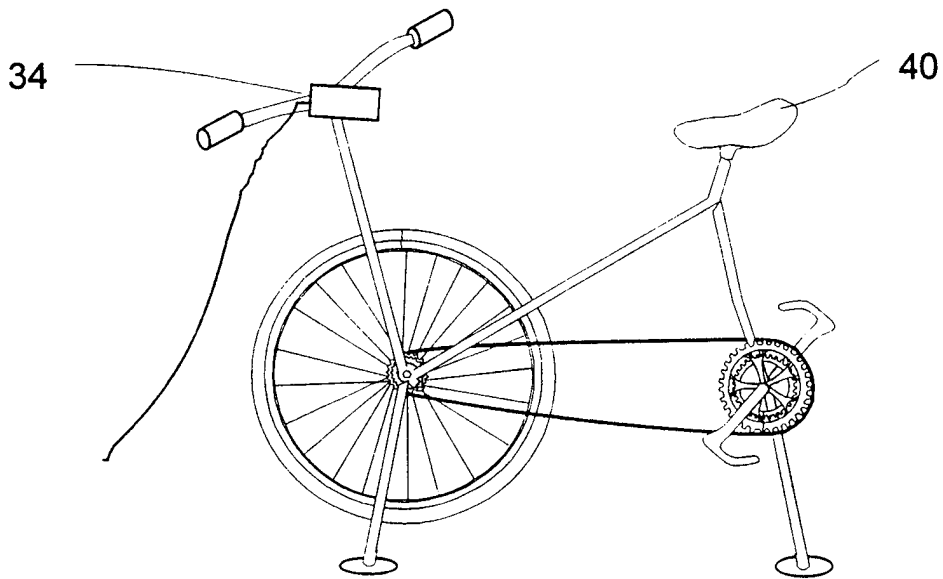

Fig. 5a

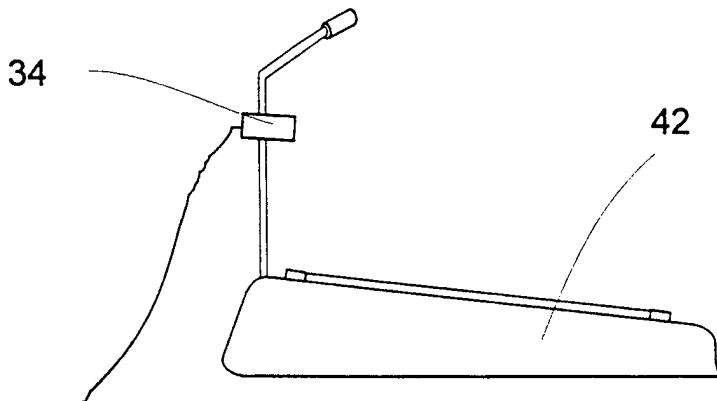

Fig. 5b

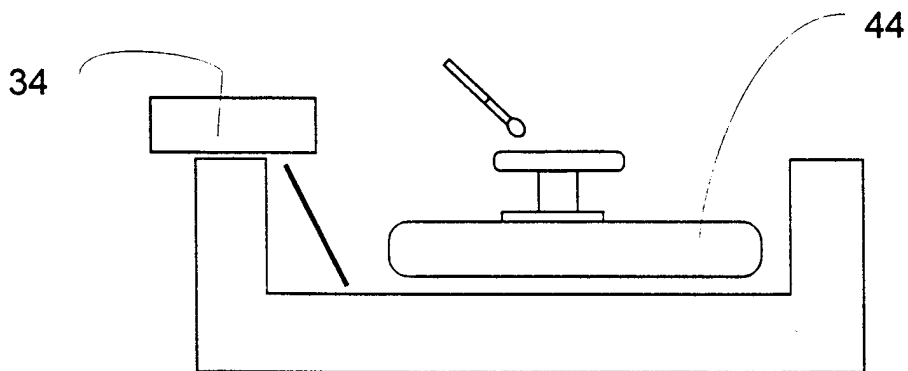

Fig. 5c

5/8

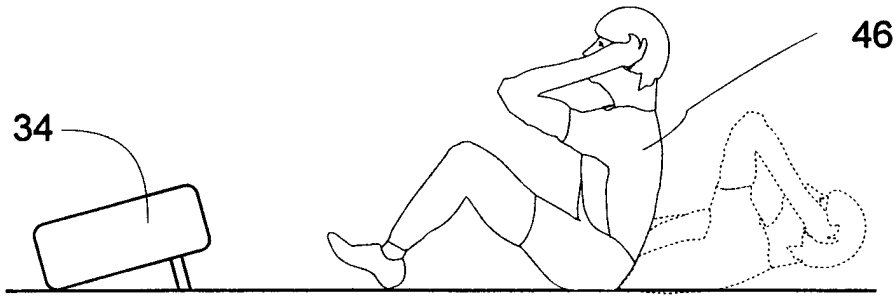

Fig. 5d

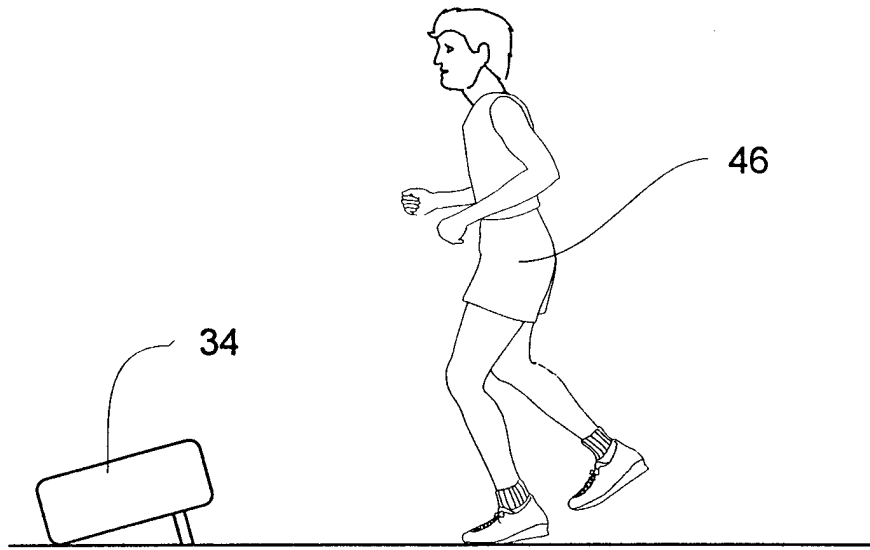

Fig. 5e

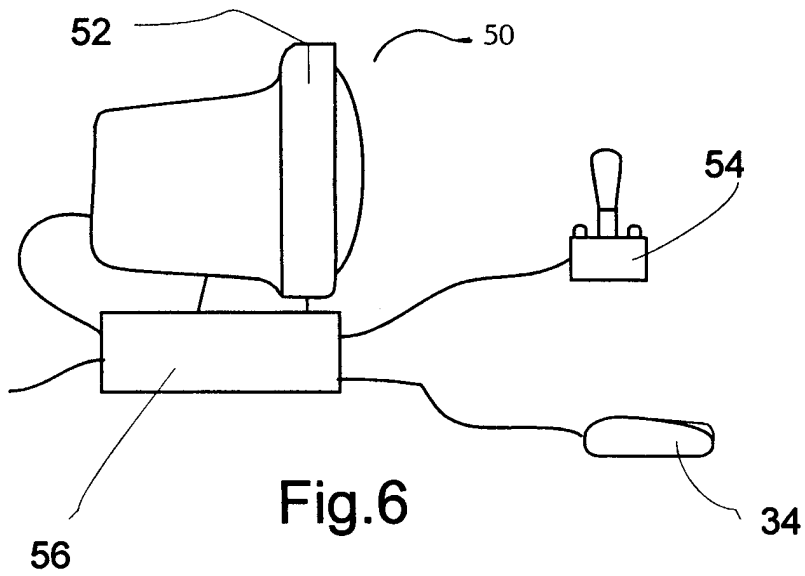

Fig. 6

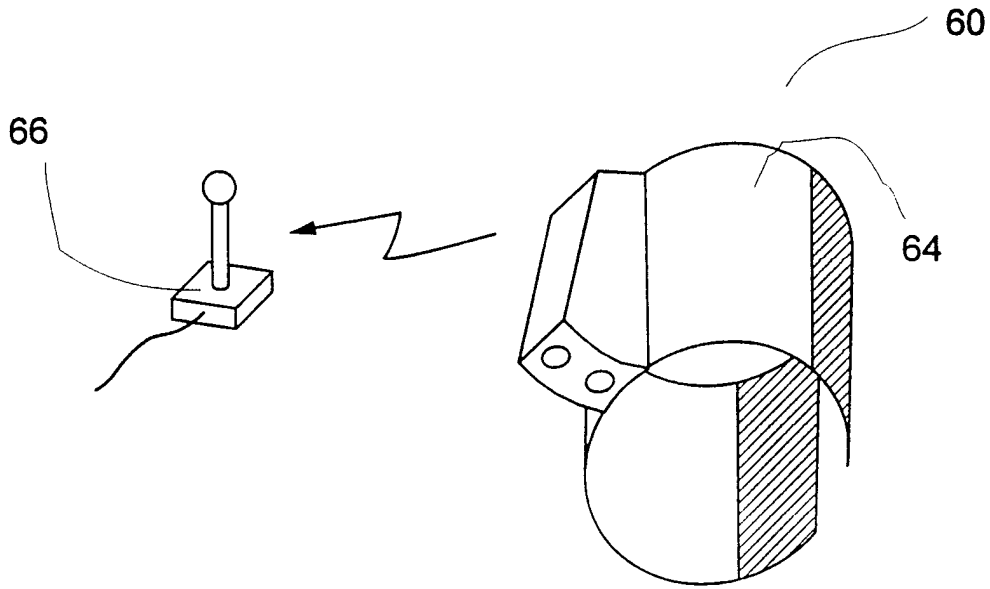

Fig.7

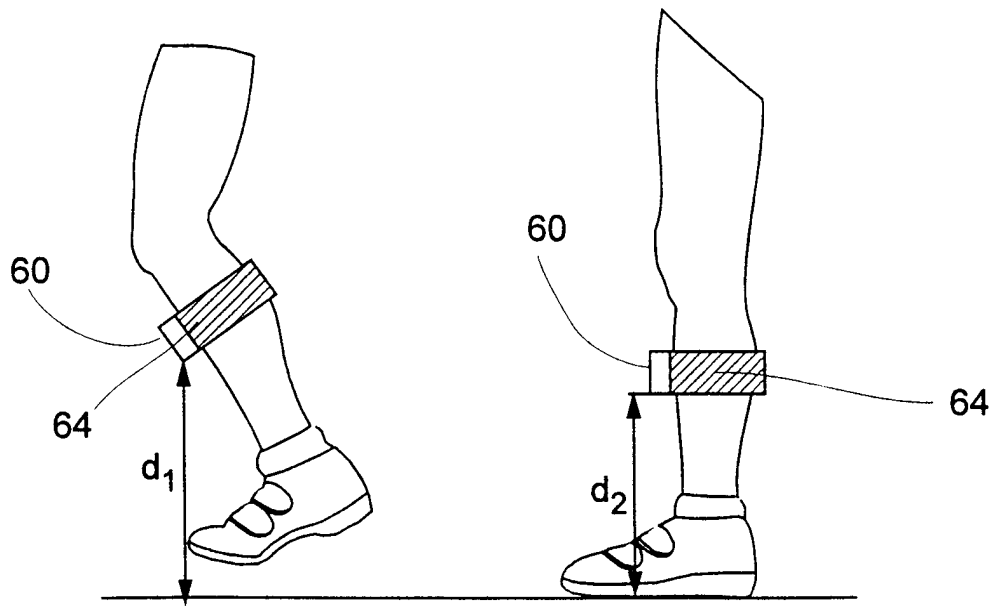

Fig.8a

Fig.8b

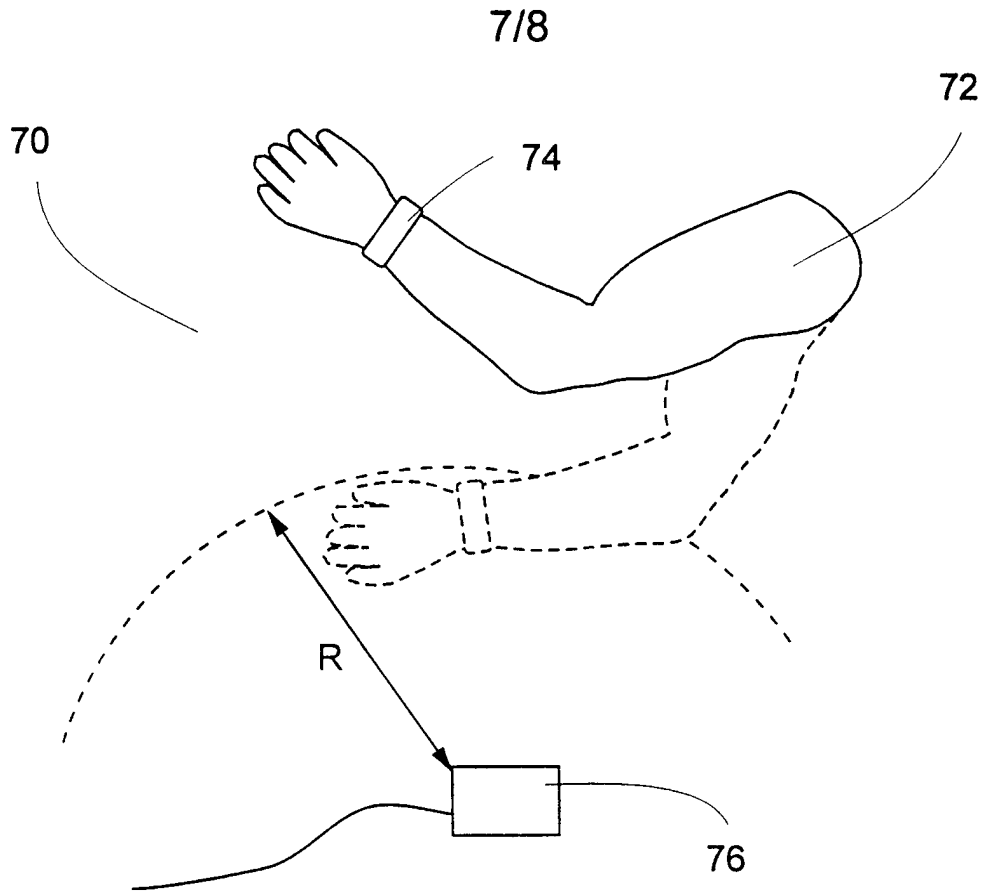

Fig.9

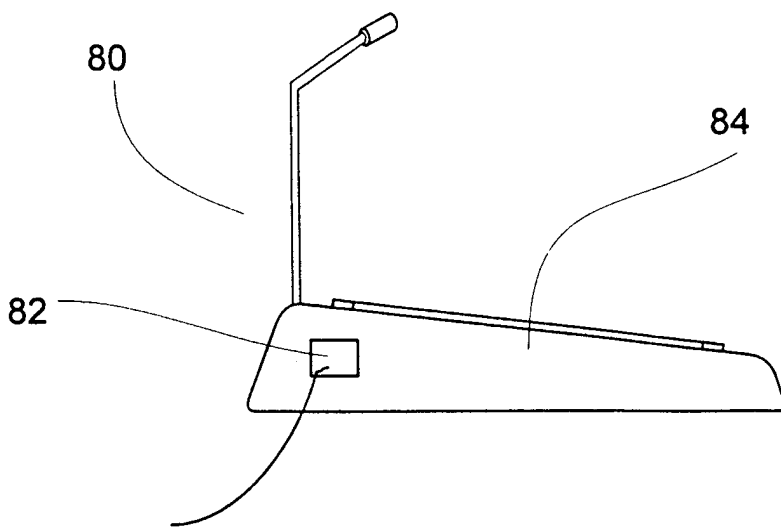

Fig.10

8/8

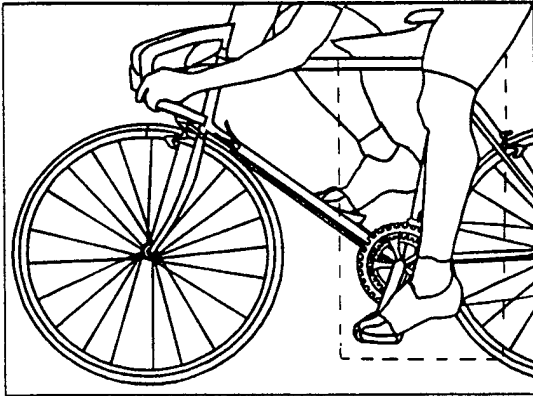

Fig. 11a

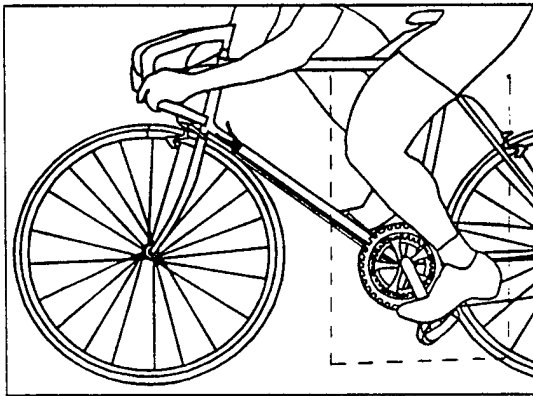

Fig. 11b

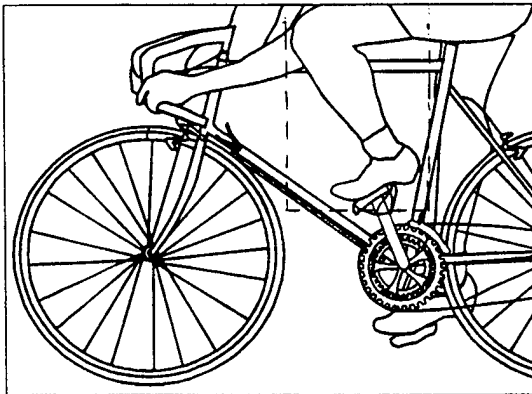

Fig. 11c

INTERNATIONAL SEARCH REPORT

International application No.

PCT/US98/02080

A. CLASSIFICATION OF SUBJECT MATTER

IPC(6) :G09B 19/00

US CL :482/7

According to International Patent Classification (IPC) or to both national classification and IPC

B. FIELDS SEARCHED

Minimum documentation searched (classification system followed by classification symbols)

U.S. : 434/112, 225, 258; 482/1, 3, 6-8, 900, 901; 434/112, 225, 258

Documentation searched other than minimum documentation to the extent that such documents are included in the fields searched

Electronic data base consulted during the international search (name of data base and, where practicable, search terms used)

C. DOCUMENTS CONSIDERED TO BE RELEVANT

Category*	Citation of document, with indication, where appropriate, of the relevant passages	Relevant to claim No.
Y	US 4,906,193 A (MCMULLEN et al) 06 March 1990, entire document.	1-27
Y	US 5,120,228 A (STAHL et al) 9 June 1992, entire document.	1-27
A	US 5,419,562 A (CROMARTY) 30 May 1995, entire document.	1-27

 Further documents are listed in the continuation of Box C.
 See patent family annex.

* Special categories of cited documents:	*T* later document published after the international filing date or priority date and not in conflict with the application but cited to understand the principle or theory underlying the invention
A document defining the general state of the art which is not considered to be of particular relevance	*X* document of particular relevance; the claimed invention cannot be considered novel or cannot be considered to involve an inventive step when the document is taken alone
E earlier document published on or after the international filing date	*Y* document of particular relevance; the claimed invention cannot be considered to involve an inventive step when the document is combined with one or more other such documents, such combination being obvious to a person skilled in the art
L document which may throw doubts on priority claim(s) or which is cited to establish the publication date of another citation or other special reason (as specified)	*A* document member of the same patent family
O document referring to an oral disclosure, use, exhibition or other means	
P document published prior to the international filing date but later than the priority date claimed	

Date of the actual completion of the international search

12 MARCH 1998

Date of mailing of the international search report

08 APR 1998

 Name and mailing address of the ISA/US
 Commissioner of Patents and Trademarks
 Box PCT
 Washington, D.C. 20231

Facsimile No. (703) 305-3230

Authorized officer

GLENN RICHMAN

Telephone No. (703) 308-3170