



(12) **United States Design Patent**
Schultheis

(10) **Patent No.:** **US D1,002,736 S**
(45) **Date of Patent:** **** Oct. 24, 2023**

(54) **PLAYING SURFACE FOR SPINNING TOP TOY**

(71) Applicant: **TOMY COMPANY, LTD.**, Tokyo (JP)

(72) Inventor: **Douglas Arthur Schultheis**,
Cumberland, RI (US)

(73) Assignee: **TOMY COMPANY, LTD.**, Tokyo (JP)

(**) Term: **15 Years**

(21) Appl. No.: **29/826,916**

(22) Filed: **Feb. 16, 2022**

(51) **LOC (14) Cl.** **21-01**

(52) **U.S. Cl.**
USPC **D21/338**

(58) **Field of Classification Search**
USPC D21/334, 336-342, 355-359, 365, 318,
D21/397, 312, 314, 320, 362, 366, 367,
(Continued)

(56) **References Cited**

U.S. PATENT DOCUMENTS

1,889,680 A * 11/1932 Marmito A63H 1/00
473/569
3,643,954 A * 2/1972 Meyer A63F 9/02
273/129 R

(Continued)

Primary Examiner — Susan Moon Lee

(74) *Attorney, Agent, or Firm* — Oliff PLC

(57) **CLAIM**

The ornamental design for a playing surface for spinning top toy, as shown and described.

DESCRIPTION

FIG. 1 is a front elevational view of a playing surface for spinning top toy, showing the new design;

FIG. 2 is a rear view thereof;
FIG. 3 is a left-side view thereof;
FIG. 4 is a right-side view thereof;
FIG. 5 is a top plan view thereof;
FIG. 6 is a bottom plan view thereof;
FIG. 7 is a front, right-side, top perspective view thereof;
FIG. 8 is a rear, left-side, bottom perspective view thereof;
FIG. 9 is a front, top perspective view thereof;
FIG. 10 is a front, right-side, top disassembled perspective view showing a state of being separated into four upper fasteners, an upper cover, a disk, a lower cover, four lower fasteners, a base, and two legs;
FIG. 11 is a rear, left-side, bottom disassembled perspective view showing a state of being separated into the four upper fasteners, the upper cover, the disk, the lower cover, the four lower fasteners, the base, and the two legs;
FIG. 12 is a cross-sectional view taken along the line 12-12 in FIG. 3;
FIG. 13 is a cross-sectional view taken along the line 13-13 in FIG. 1;
FIG. 14 is an enlarged detail perspective view of one of the upper fasteners shown disassembled in FIGS. 10 and 11;
FIG. 15 is another enlarged detail perspective view of one of the upper fasteners shown disassembled in FIGS. 10 and 11;
FIG. 16 is an enlarged detail perspective view of one of the lower fasteners shown disassembled in FIGS. 10 and 11;
FIG. 17 is another enlarged detail perspective view of one of the lower fasteners shown disassembled in FIGS. 10 and 11;
FIG. 18 is an enlarged detail perspective view of one of the legs shown disassembled in FIGS. 10 and 11;
FIG. 19 is another enlarged detail perspective view of one of the legs shown disassembled in FIGS. 10 and 11;
FIG. 20 is a front, right-side, top perspective view where the material visible through transparent parts is not shown for clarity;
FIG. 21 is a rear, left-side, bottom perspective view where the material visible through transparent parts is not shown for clarity; and,
FIG. 22 is a front, top perspective view where the material visible through transparent parts is not shown for clarity.

1 Claim, 18 Drawing Sheets

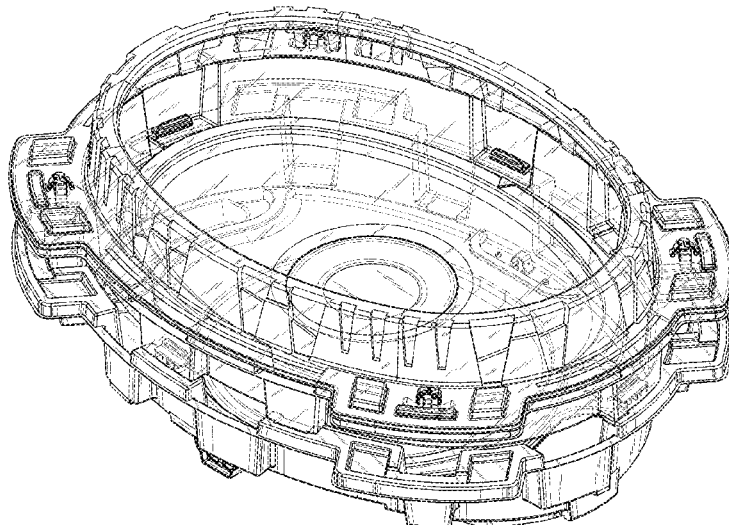

(58) **Field of Classification Search**

USPC D21/385, 455, 456, 460, 461, 484,
 D21/491-501, 561, 564; 273/242,
 273/244-247, 259, 277, 287, 317.3,
 273/108.1, 108.5, 118 D, 236-240, 283,
 273/309, 441, 461, 108.2, 108.3, 113,
 273/115, 116, 241, 280, 282.1, 282.2,
 273/282.3, 289, 148 R, 440, 444, 450,
 273/453, 459, 109, 110, 108, 456, 443;
 D6/406.1, 406.3, 406.4, 406.6; D19/86,
 D19/92, 95, 87, 113, 75, 77, 78, 80;
 108/14, 62, 43, 67; 434/416, 247, 248,
 434/251, 408, 413, 145, 430; 446/82,
 446/168, 236, 256, 257, 259, 262, 263,
 446/491, 233; D7/538-550.1, 552.2,
 D7/553.1-553.8, 554.1-554.4, 558,
 D7/584-588, 601, 602, 359, 354, 356;
 D9/737, 756, 758-761, 414, 424-433,
 D9/456, 499; D30/121, 129-133;
 D11/143, 144, 152, 153, 155, 156, 164;
 47/65, 65.5, 65.6, 66.7, 71, 73-75, 39;
 473/569, 570; 463/69
 CPC A63F 3/00; A63F 3/00003; A63F 3/00028;
 A63F 3/00041; A63F 3/00044; A63F
 3/00047; A63F 3/00173; A63F 3/00176;
 A63F 3/00214; A63F 3/00261; A63F
 3/00643; A63F 3/00646-00659; A63F
 3/04; A63F 2003/00182; A63F
 2003/00223; A63F 2003/00457; A63F
 2003/0046; A63F 2003/00463; A63F
 2003/00466; A63F 2003/0047; A63F
 2003/00485; A63F 2003/00492; A63F
 2003/00507; A63F 2003/00514; A63F
 2003/00533; A63F 2003/00552; A63F
 2003/00558; A63F 2003/00943; A63F
 2003/00946; A63F 2003/00952-00962;
 A63F 2003/00974; A63F 7/00; A63F
 7/06; A63F 7/0612; A63F 7/0604; A63F
 7/0616-0636; A63F 7/30; A63F 7/36;

A63F 7/0005; A63F 7/0017; A63F
 7/0023; A63F 2007/0035; A63F
 2007/367; A63F 2007/3674; A63F 9/00;
 A63F 9/16; A63F 9/02; A63F 2009/165;
 A63H 1/00; A63H 1/02; A63H 1/04;
 A63H 1/10

See application file for complete search history.

(56)

References Cited

U.S. PATENT DOCUMENTS

3,674,271 A * 7/1972 De Gelder A63H 1/00
 446/233
 3,841,636 A * 10/1974 Meyer A63F 9/14
 446/3
 D238,388 S * 1/1976 Monroe D21/338
 D248,357 S * 7/1978 Daenen D7/505
 4,292,756 A * 10/1981 Jaworski A63H 1/00
 446/246
 D348,805 S * 7/1994 Cautereels D7/602
 5,377,860 A * 1/1995 Littlejohn B65D 43/0212
 220/784
 D371,578 S * 7/1996 Henderson D21/338
 D563,671 S * 3/2008 Cornwell D3/905
 D696,111 S * 12/2013 Sundy D9/429
 D884,078 S * 5/2020 Hama D21/338
 D884,797 S * 5/2020 Schultheis D21/338
 D886,903 S * 6/2020 Ishii D21/338
 10,702,767 B2 * 7/2020 Campos A63F 9/16
 D900,228 S * 10/2020 Schultheis D21/338
 D912,157 S * 3/2021 Hama D21/338
 11,154,769 B2 * 10/2021 Schultheis A63H 1/00
 11,311,796 B2 * 4/2022 Schultheis A63H 1/00
 D951,357 S * 5/2022 Schultheis D21/338
 D952,042 S * 5/2022 Schultheis D21/338
 D961,683 S * 8/2022 Schultheis D21/338
 D970,635 S * 11/2022 Schultheis D21/456
 2010/0320682 A1 * 12/2010 Derrah A63H 7/00
 273/108.1
 2020/0139224 A1 * 5/2020 Schultheis A63F 9/16
 2021/0220724 A1 * 7/2021 Schultheis A63F 9/16

* cited by examiner

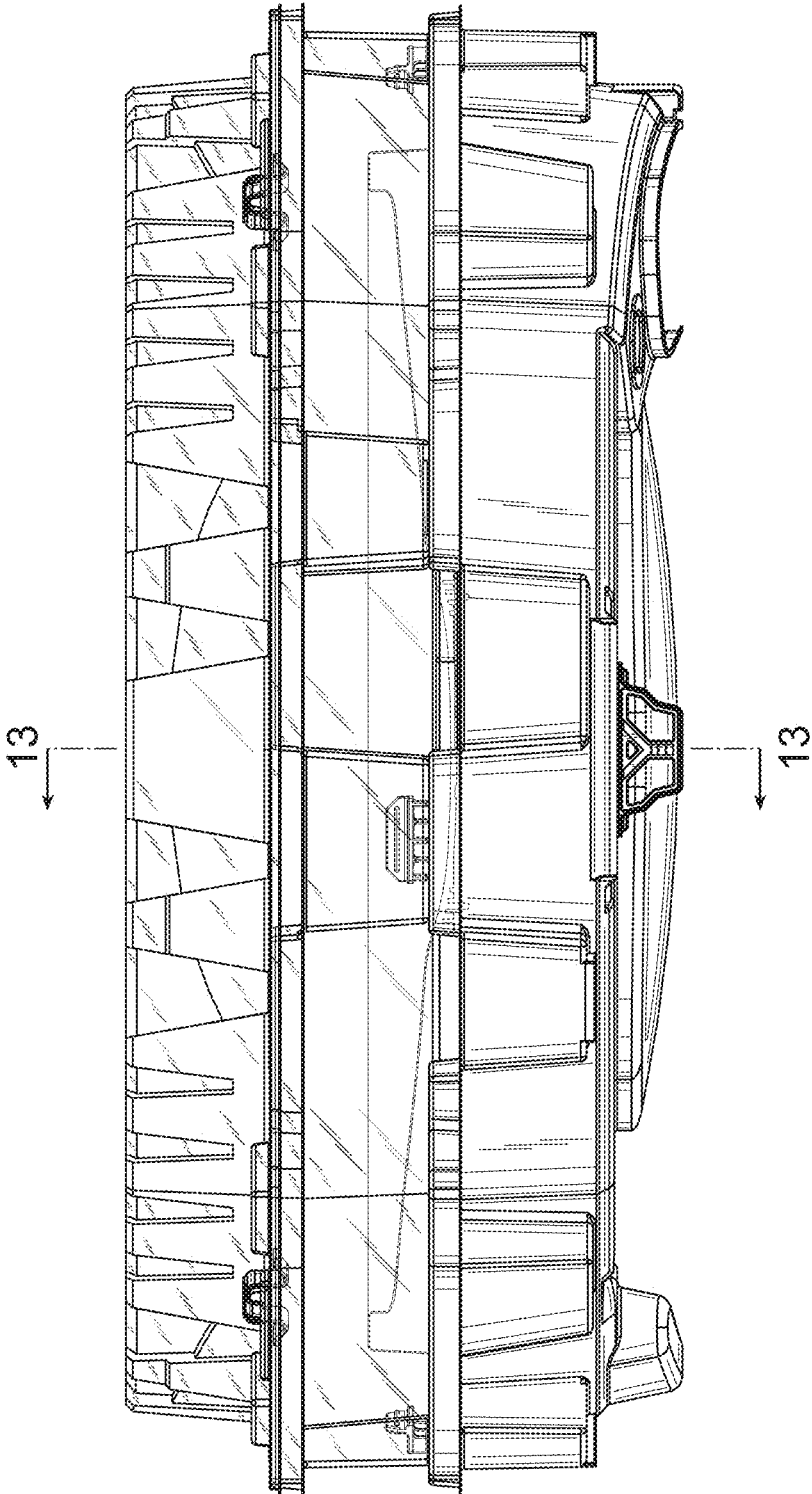

FIG. 1

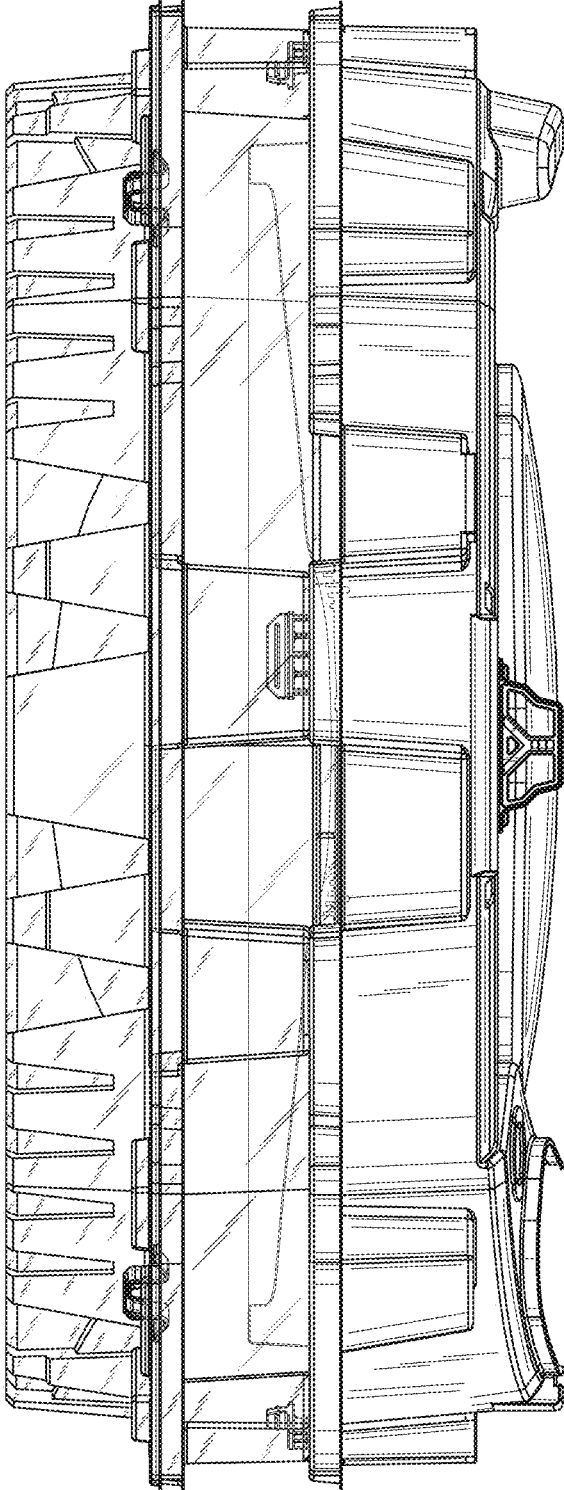

FIG. 2

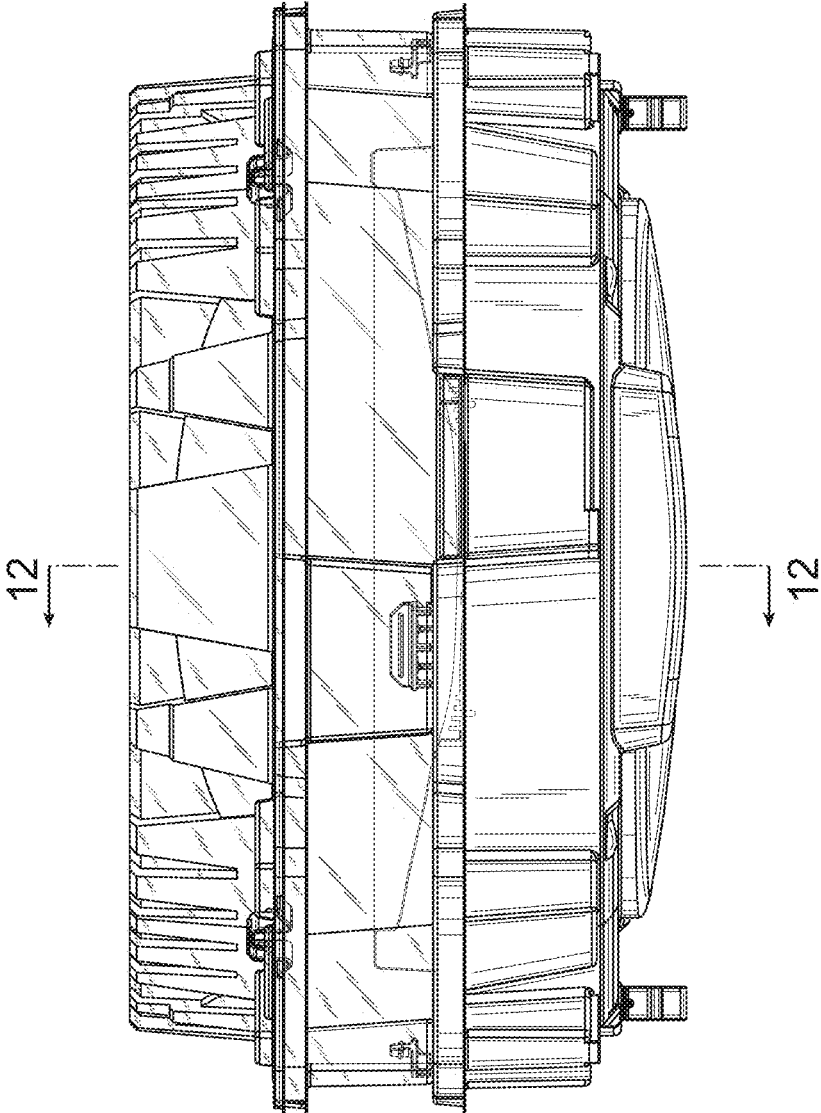

FIG. 3

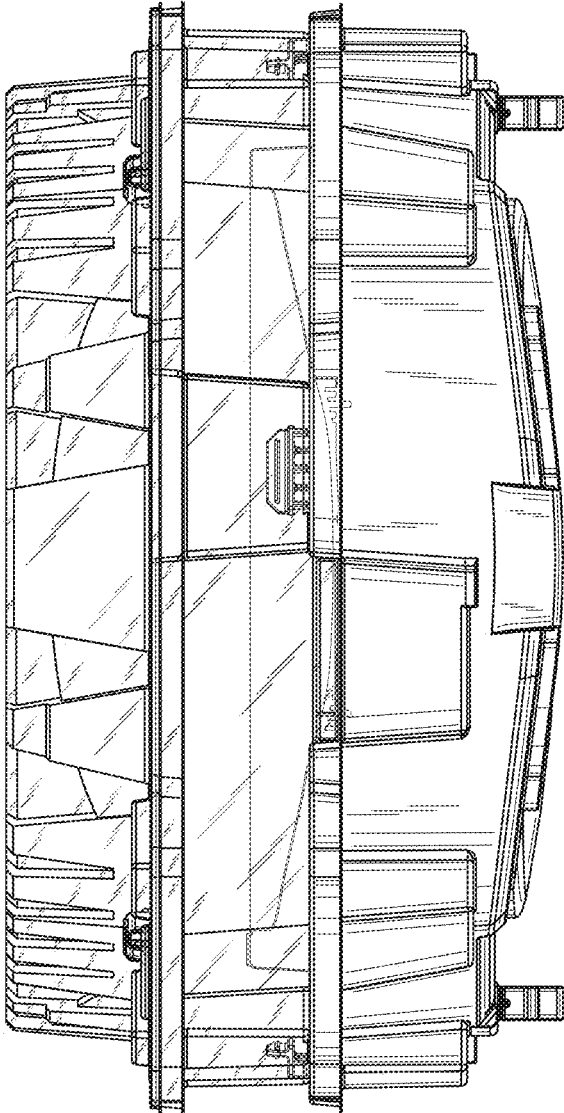

FIG. 4

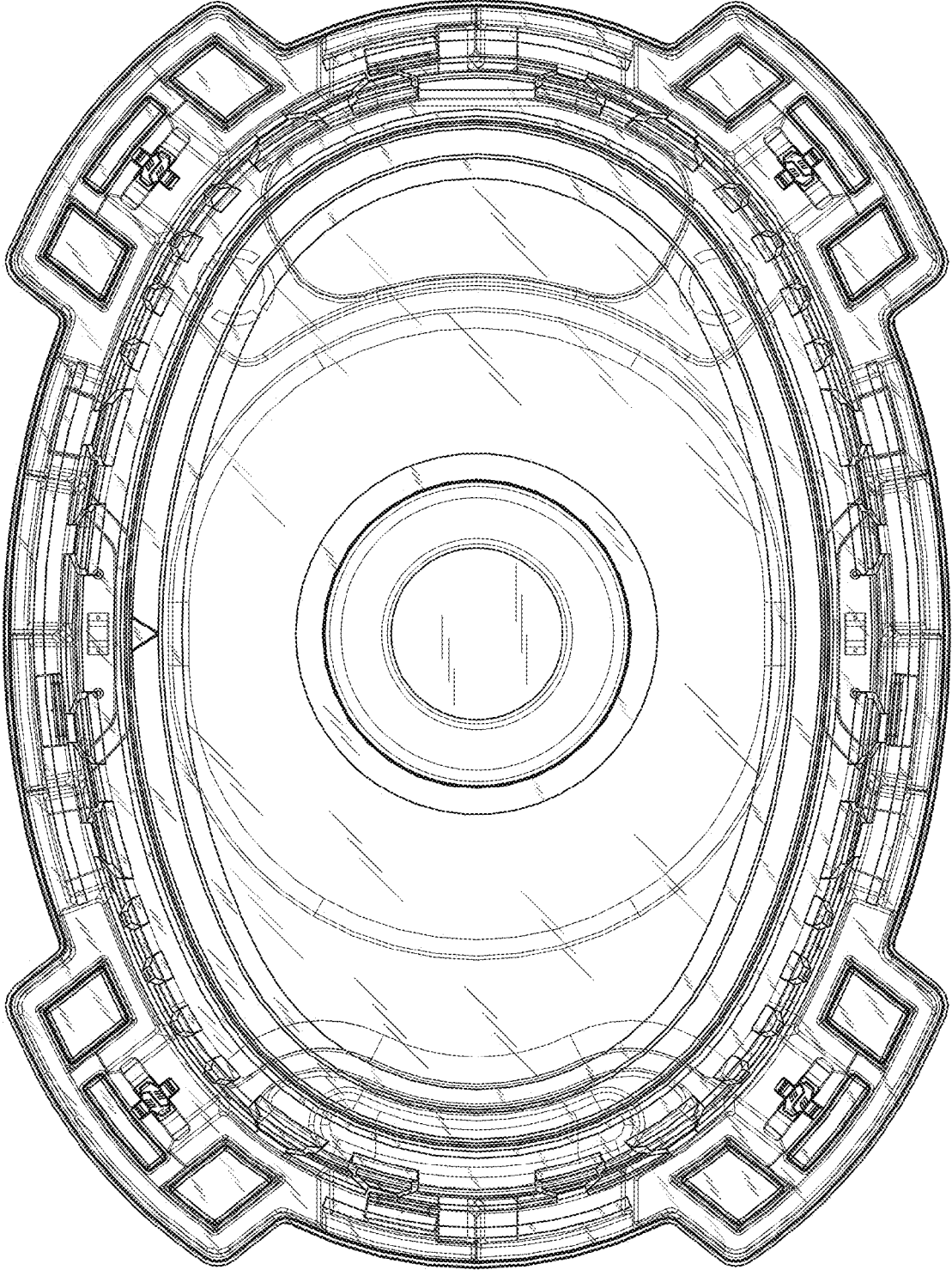
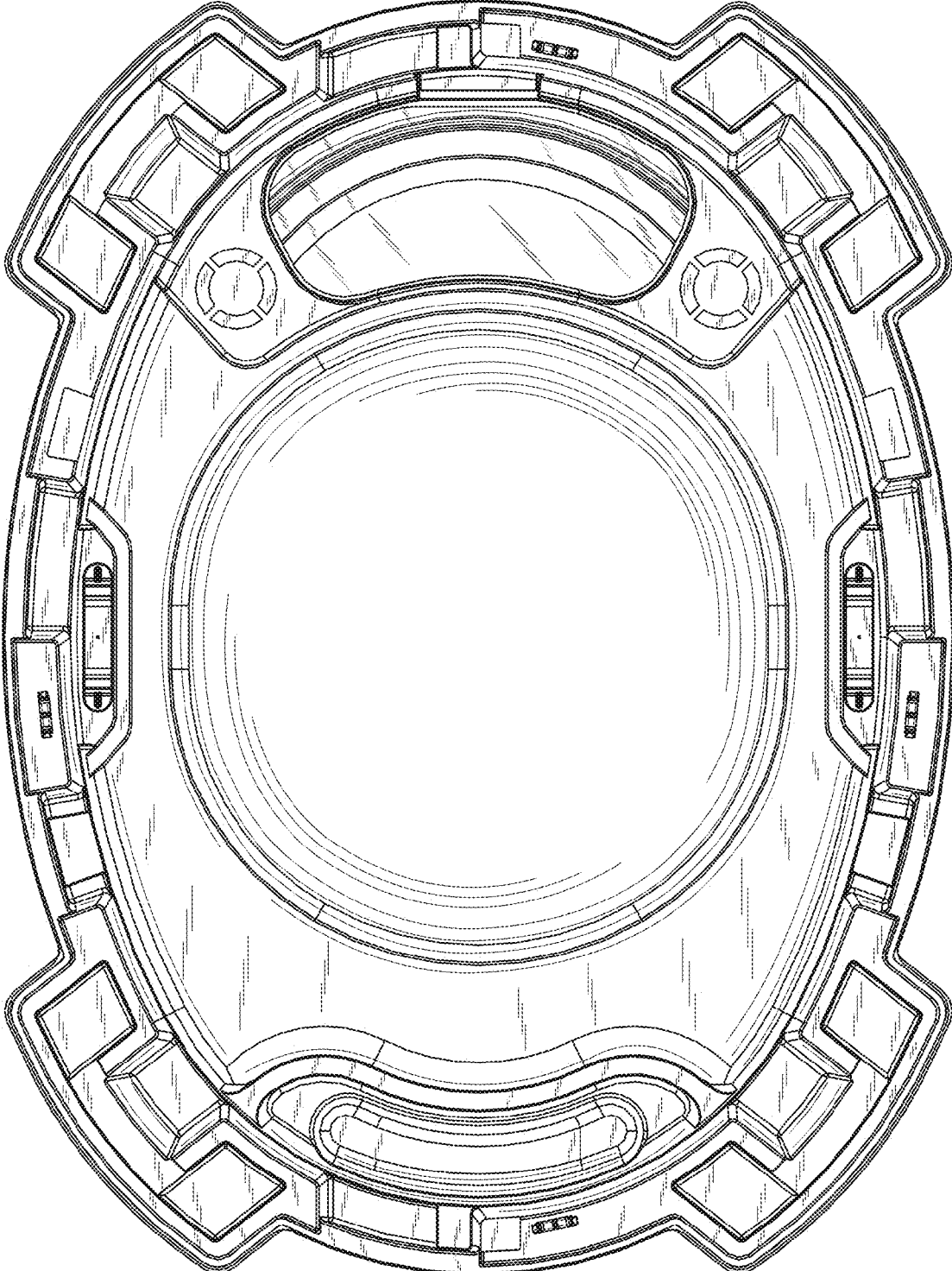

FIG. 5

FIG. 6



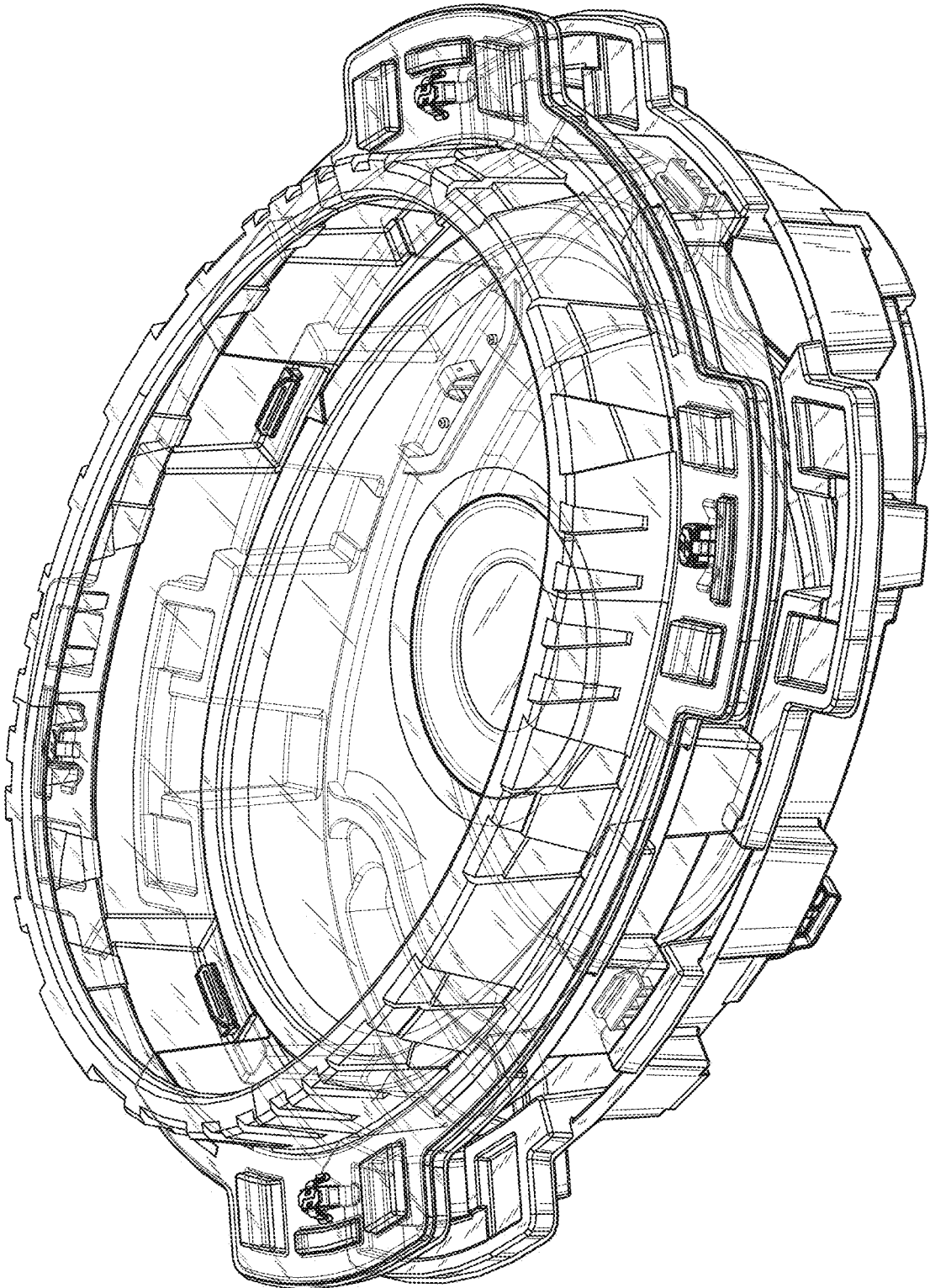

FIG. 7

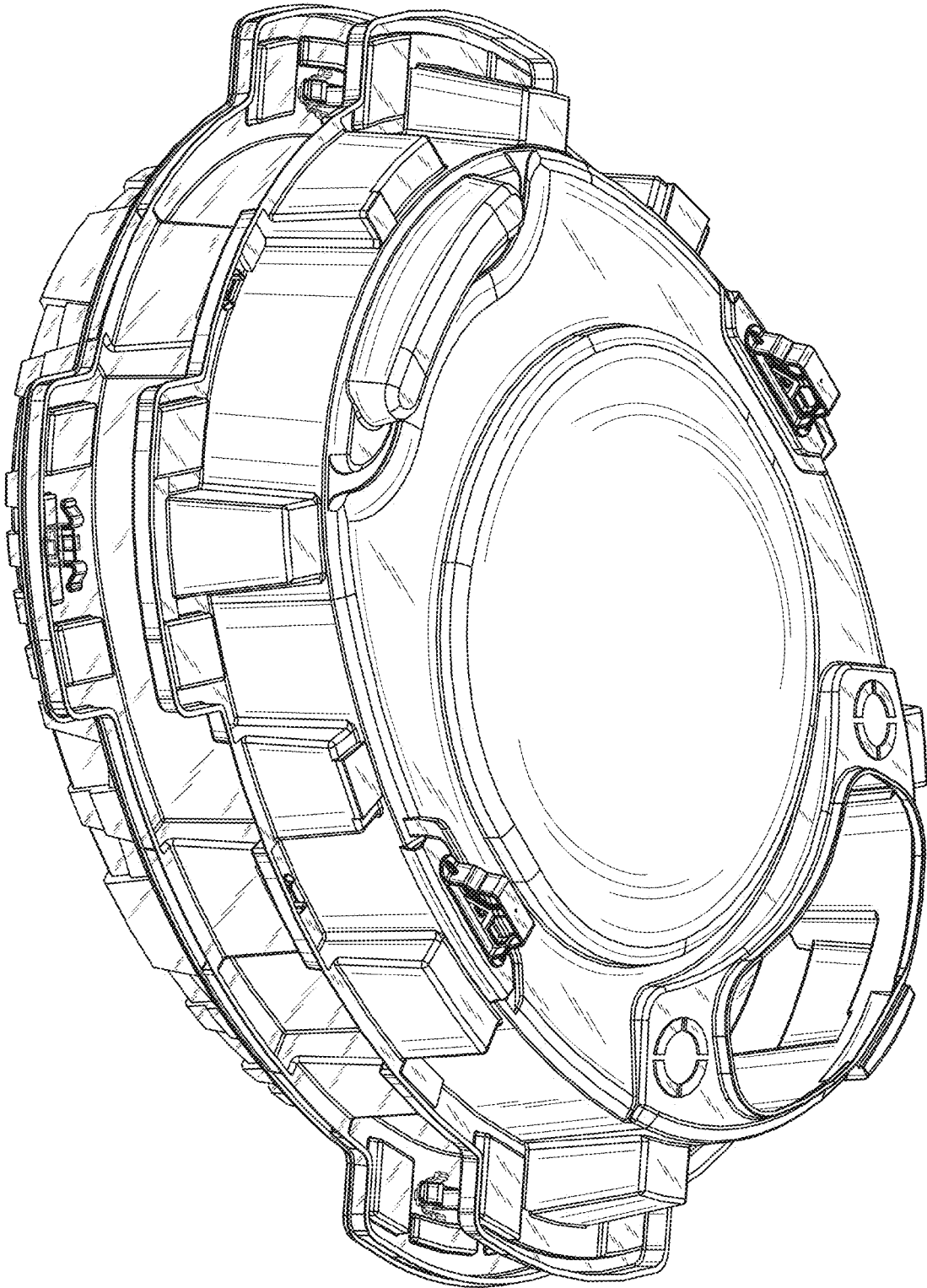

FIG. 8

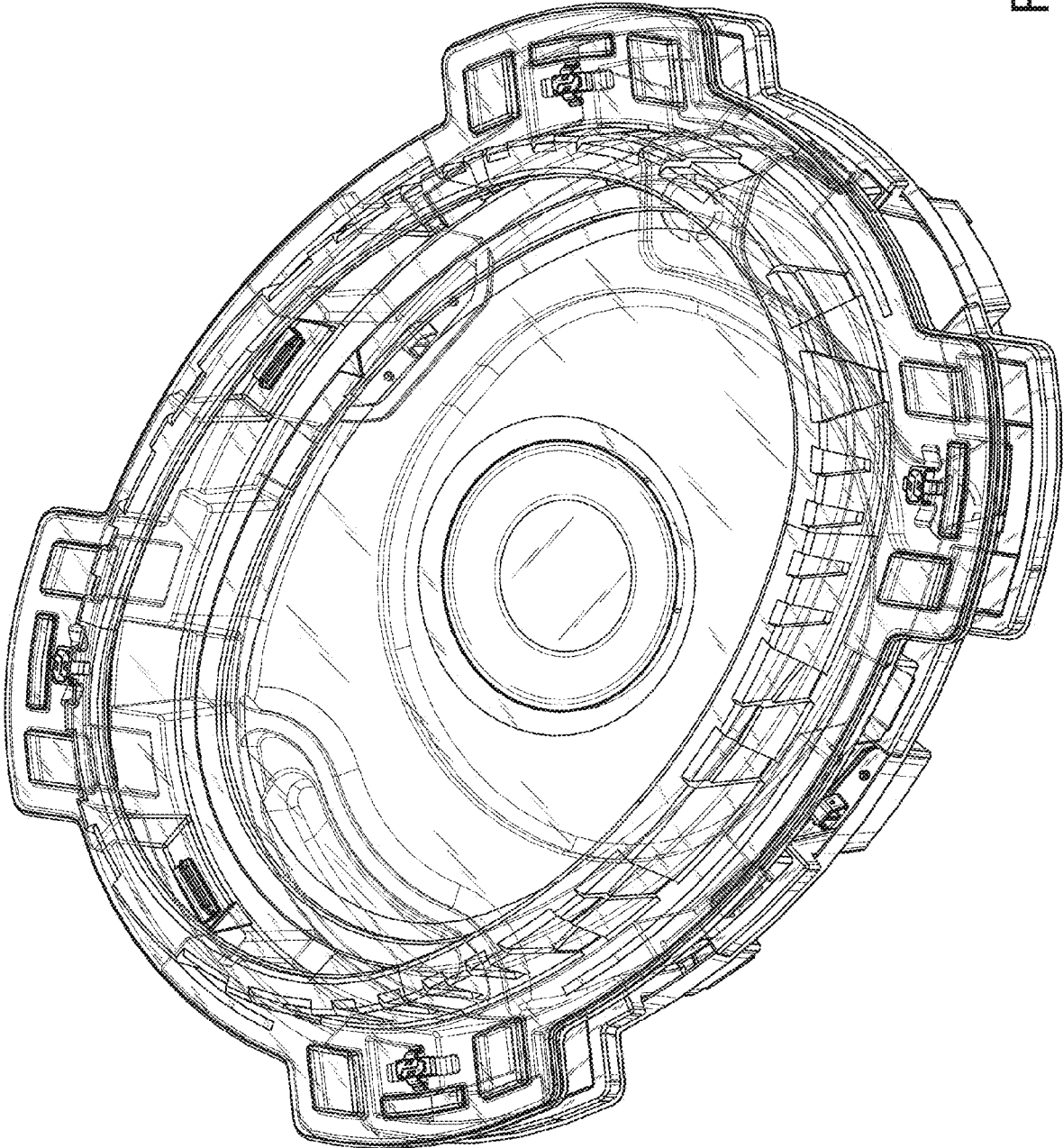

FIG. 9

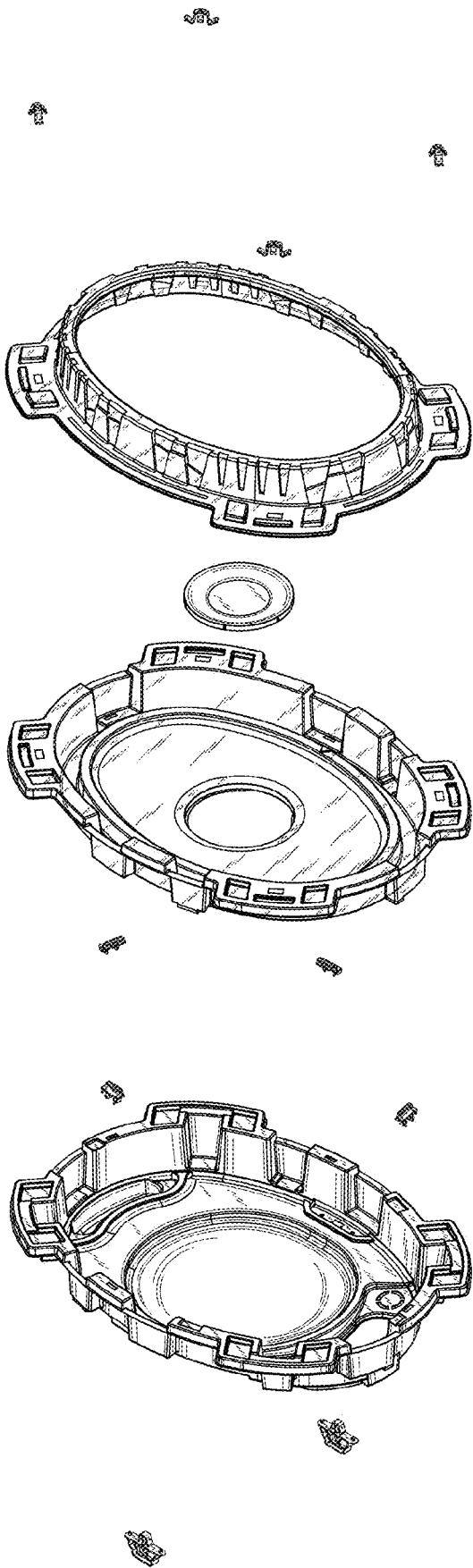

FIG. 10

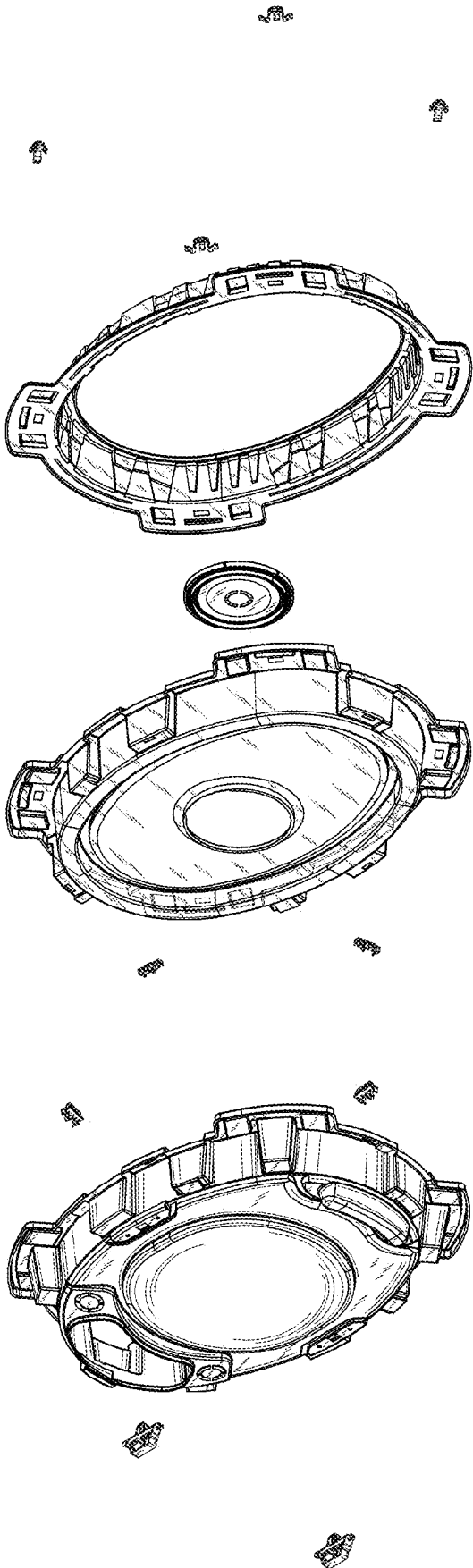

FIG. 11

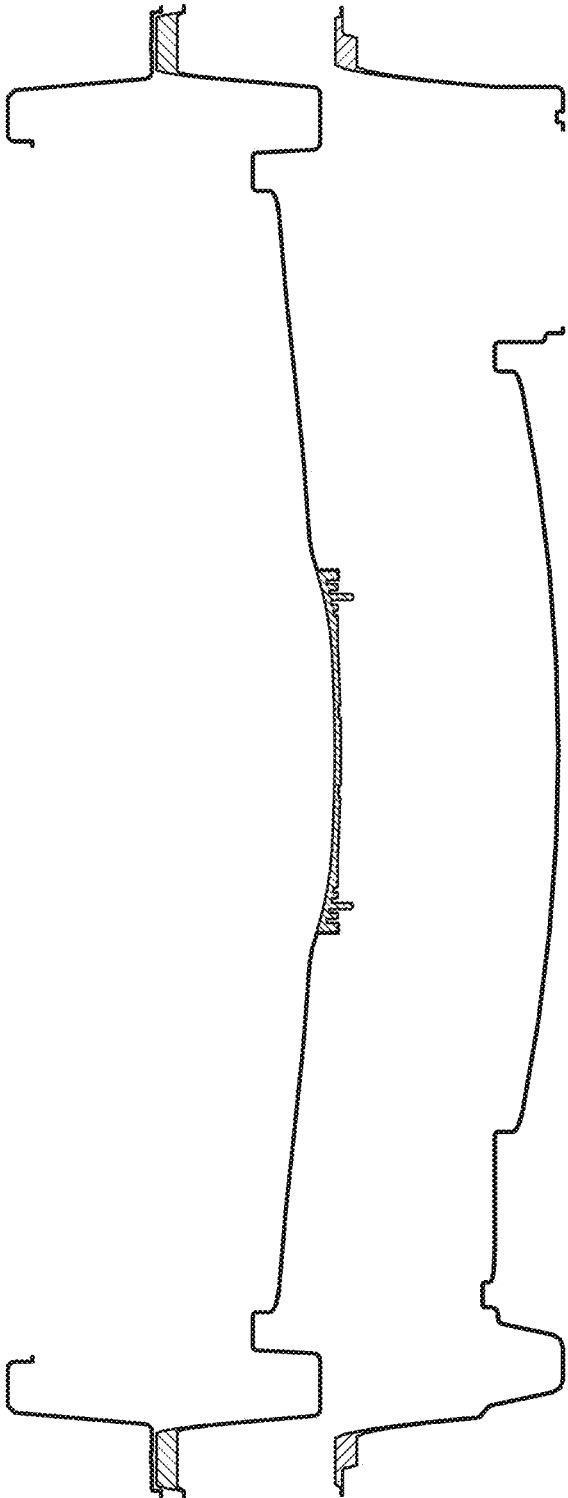

FIG. 12

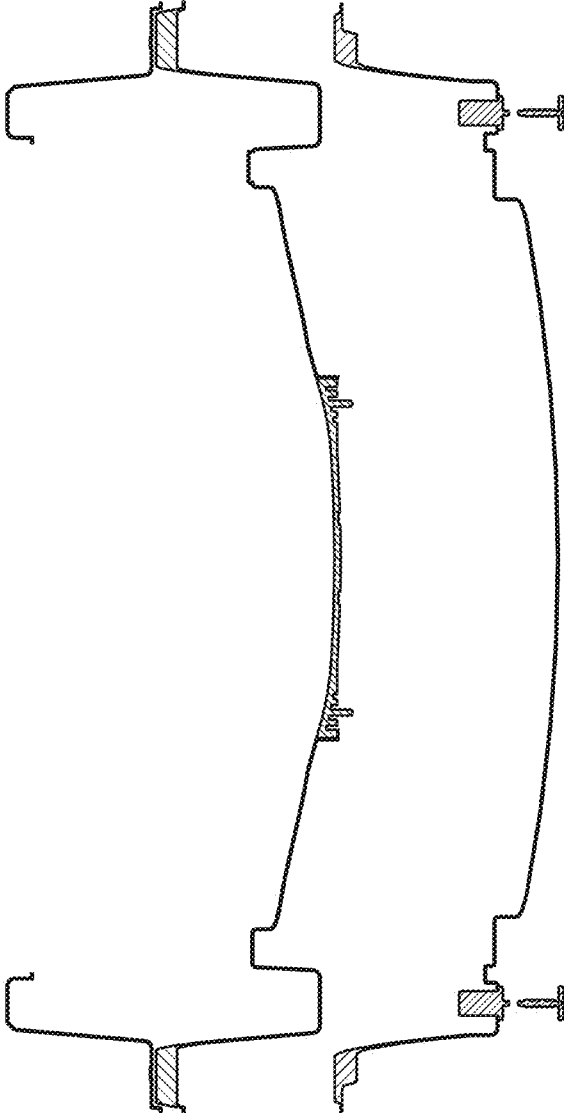

FIG. 13

FIG. 14

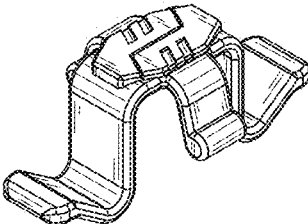

FIG. 15

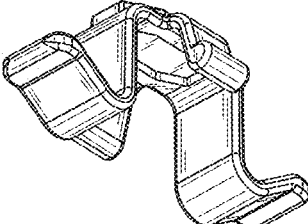

FIG. 16

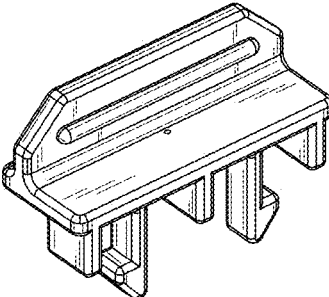

FIG. 17

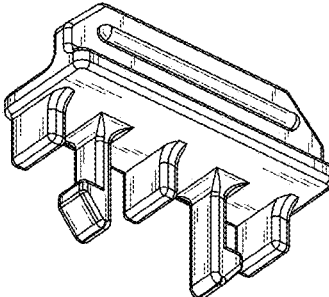

FIG. 18

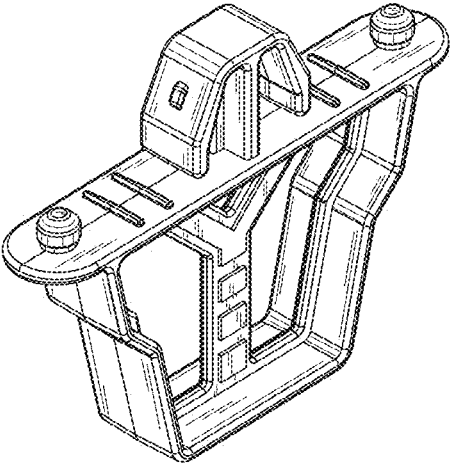
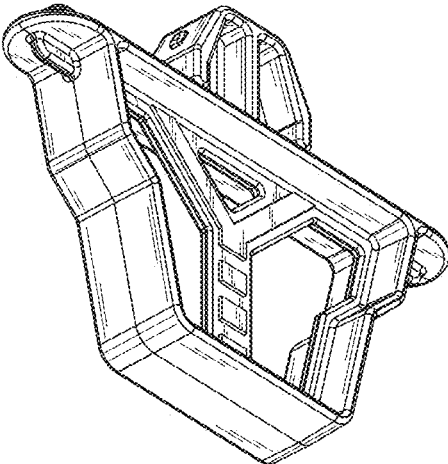

FIG. 19



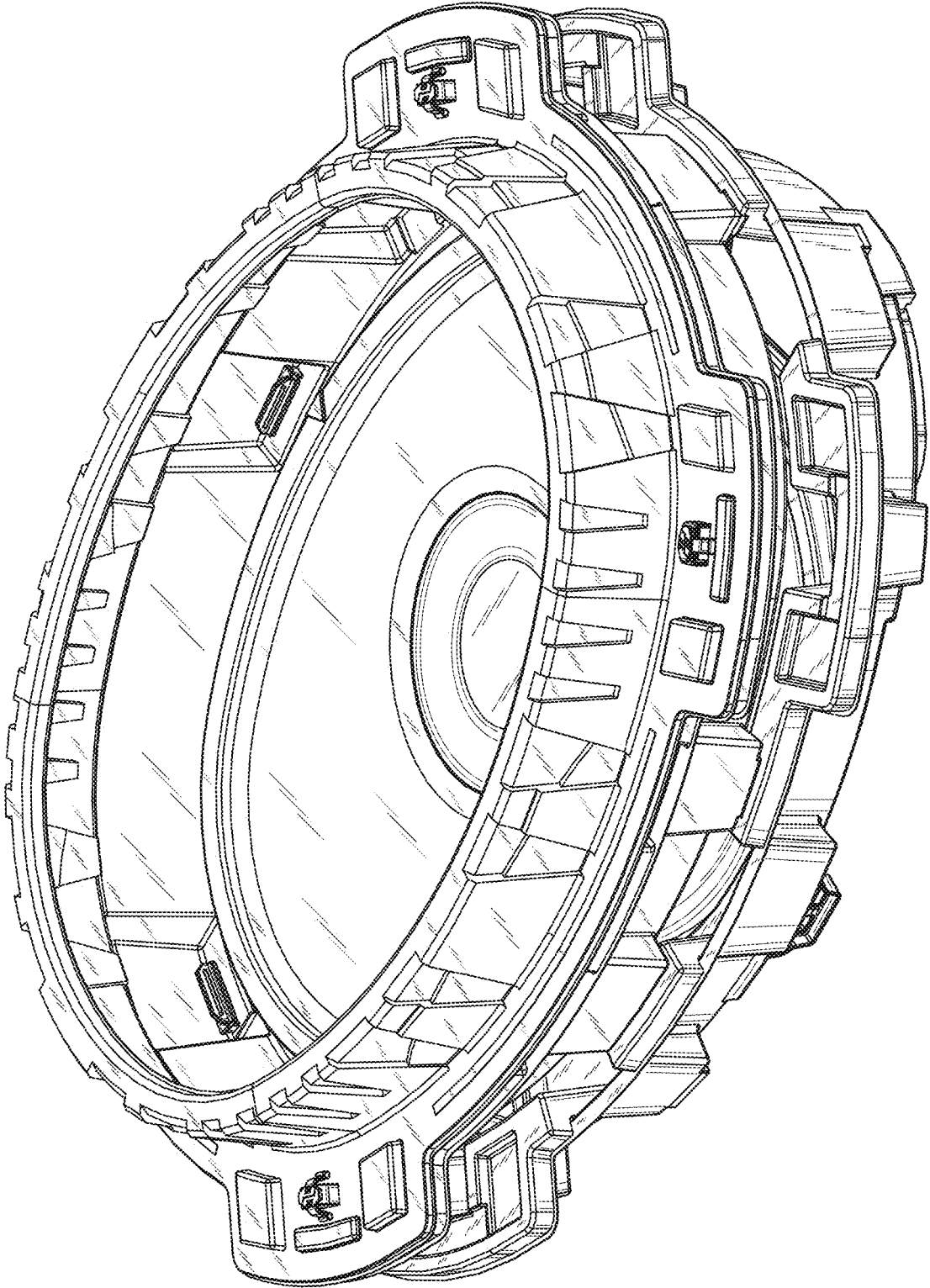

FIG. 20

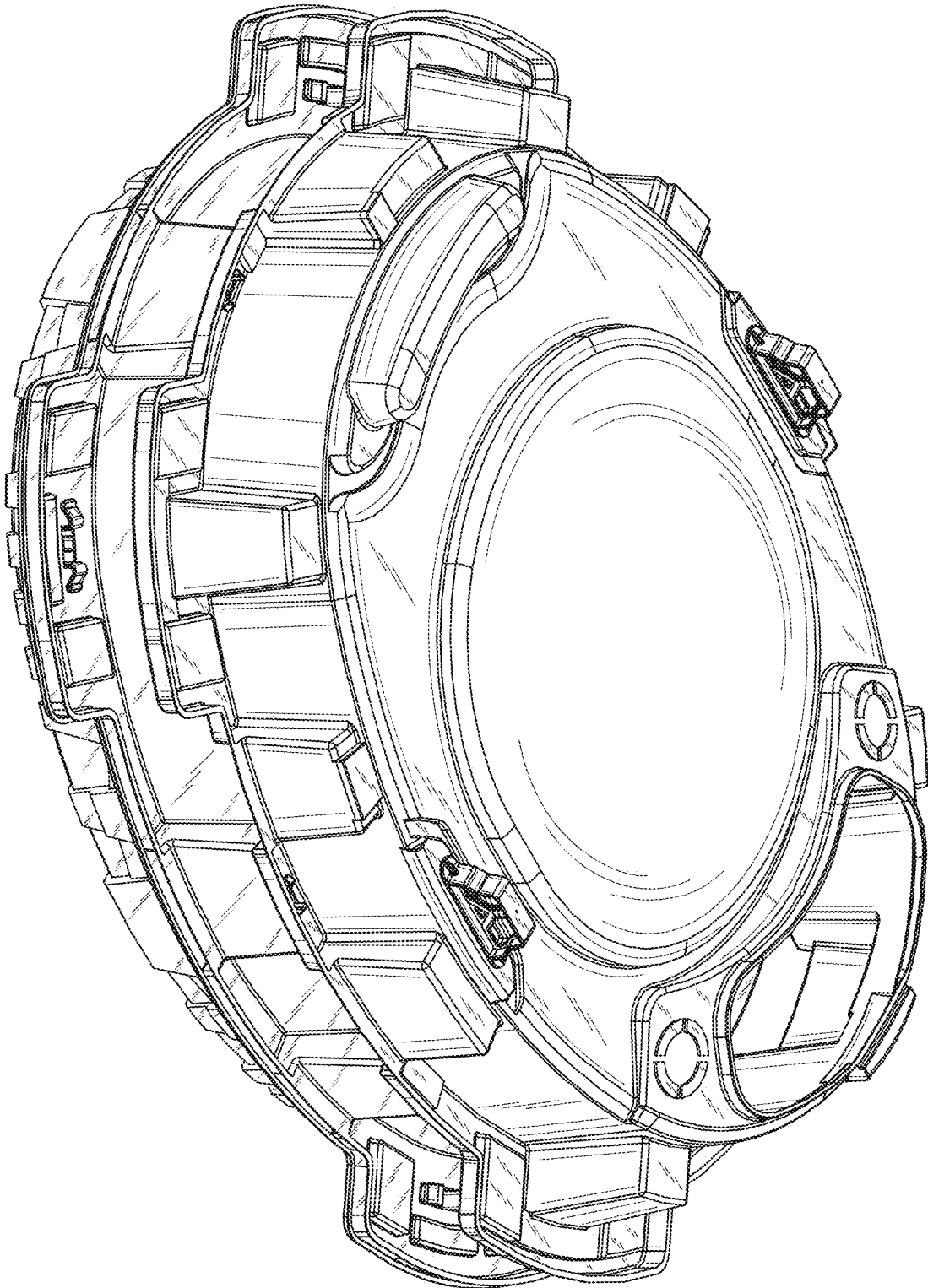

FIG. 21

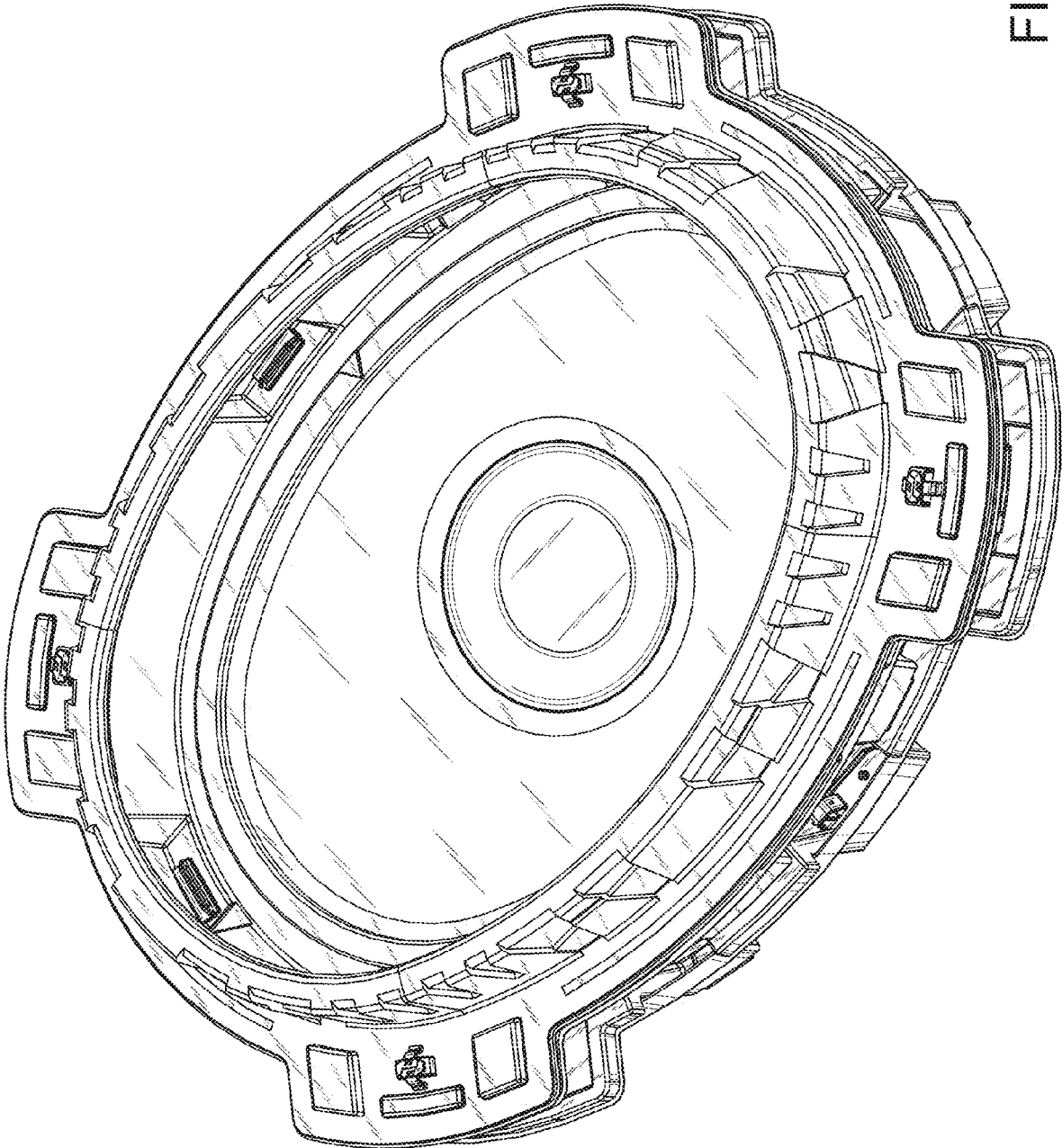

FIG. 22