

E. DOUGHERTY.

Water-Wheels.

No. 134,040.

Patented Dec. 17, 1872.

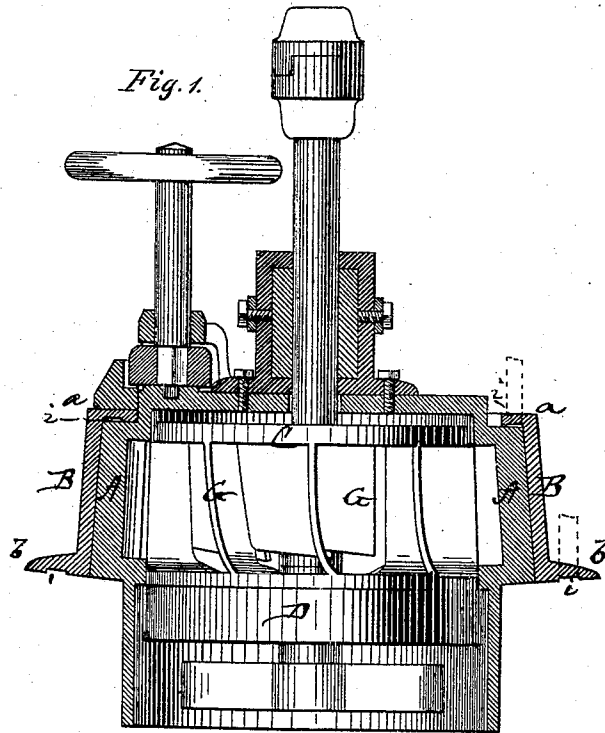

Fig. 2.

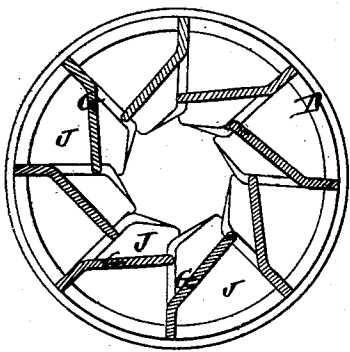
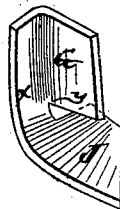

Fig. 3.



Witnesses:

Henry N. Miller
A. L. Gwert.

Inventor.

Eliphalet Dougherty.
per Alexander Mason
Attorneys.

UNITED STATES PATENT OFFICE

ELIPHALET DOUGHERTY, OF MARION, OHIO.

IMPROVEMENT IN WATER-WHEELS.

Specification forming part of Letters Patent No. 134,040, dated December 17, 1872.

To all whom it may concern:

Be it known that I, ELIPHALET DOUGHERTY, of Marion, in the county of Marion and in the State of Ohio, have invented certain new and useful Improvements in Water-Wheels; and do hereby declare that the following is a full, clear, and exact description thereof, reference being had to the accompanying drawing and to the letters of reference marked thereon making a part of this specification.

My present invention is intended as an improvement upon the water-wheel for which Letters Patent were granted to me May 31, 1870; and it consists, first, in adapting the form of the wheel casing and register to the varying velocities of the water which acts upon the portions of the buckets at different depths. All parts of the periphery of the buckets revolve with the same velocity; but the water which acts upon the buckets at top and bottom at different depths moves with different velocities. The lower stratum of water moving faster than the upper stratum, if the lower part of the bucket moves with the lower stratum of water the upper parts of the buckets must move faster than its stratum of water; hence it not only loses all of the benefits of its own stratum of water, but virtually runs in back water; or, if the upper part of the bucket moves with the stratum of water, the lower part must move slower than its stratum, and hence fails to receive the full benefit of the water which acts on that part of the bucket. Second, in providing the register of a water-wheel with oil chambers or channels, and a suitable oiling device for lubricating the same; and, third, in the construction of the buckets of the wheel; all of which will be hereinafter more fully set forth.

In order to enable others skilled in the art to which my invention appertains to make and use the same, I will now proceed to describe its construction and operation, referring to the annexed drawing, in which—

Figure 1 is a longitudinal vertical section of the casing and register, showing a side elevation of the wheel; Fig. 2 is a horizontal section of the wheel; and Fig. 3 is a perspective view of one of the buckets.

A represents the wheel-casing, provided

with the usual chutes or water-passages, and constructed in conical form, substantially as described in my former patent above referred to. Surrounding this casing is the register B, also made in conical form to correspond with the shape of the casing. The register B is, around its upper edge, provided with an inward-projecting flange, *a*, resting upon the top of the casing, as shown in Fig. 1, and around its lower edge provided with an outward-projecting flange, *b*, the under side of which is inclined to correspond with the inclination of the bottom of the casing. The conical or conified form of the register allows the different stratum of the water to pass into and act on the wheel with perfect regularity. On the under side of the flange *a* is a continuous groove, *i*, forming an oil-chamber or oil-channel for the purpose of oiling the bearing surfaces of the flange and casing, as well as the outer surface of the casing and inner surface of the register. Oil is admitted into the oil-chamber *i* by means of a tube extending up above the water, or by a water-tight globe attached to the top of the register, or by any other suitable means. In like manner the under surface of the lower flange *b* is provided with an oil-chamber, *i*, for oiling its bearing-surface. This oiling of the register is of great importance, as it is very often the case that the register sticks and is hard to move, while by having it constantly well oiled it can be moved with perfect ease. The oiling is done every time the register is moved to let on or shut off the water, said movement being effected by the usual pinion and cogged segment, or by any other suitable and convenient means. C represents the top rim, D the bottom rim, and G G the buckets, of my wheel. The bottom rim D, instead of being horizontal with the buckets resting on it, as in my former case, is vertical, or, in other words, standing on edge, and the buckets G G are constructed in a different manner. The upper part of the bucket is precisely the same and constructed in precisely the same manner, and by the same rules as described in my former patent; but from the lower edge of the outer part *a* of the bucket extends downward a wing, J, which is inclined and also projects inward beyond the wing one-half of its width, un-

der the inner part *y* of the bucket. The bottom rim *D* is attached to the outer edge of this wing.

It will thus be seen that I combine an upper and lower bucket in one, and the lower bucket, projecting inward toward the center of the wheel and past the inner line of the vertical bucket, receives the water from the vertical issue in the upper bucket, and causes all the water to act on the bucket with its gravity after it has expended its percussion on the upper bucket.

By this construction of the bucket I get not only the benefit of the entire projectile force of the water, but also the benefit of the force of its gravity as it passes down the inclined wing *J*.

Having thus fully described my invention, what I claim as new, and desire to secure by Letters Patent, is—

1. The combination of the conical wheel *C* *D* *G*, conical casing *A*, and conical register *B* with flanges *a* *b*, all constructed substantially as and for the purposes herein set forth.

2. Oil-chambers or oil-channels *i* *i* formed in the register of a water-wheel, substantially as and for the purposes herein set forth.

3. The buckets *G*, constructed as described, and provided with the downward and inward projecting wing *J*, substantially as and for the purposes herein set forth.

In testimony that I claim the foregoing I have hereunto set my hand this 12th day of August, 1872.

ELIPHALET DOUGHERTY.

Witnesses:

EDM. F. BROWN,
J. M. MASON.