

F. FARRELL.
Car-Seats.

No. 139,561.

Patented June 3, 1873.

Fig. 1.

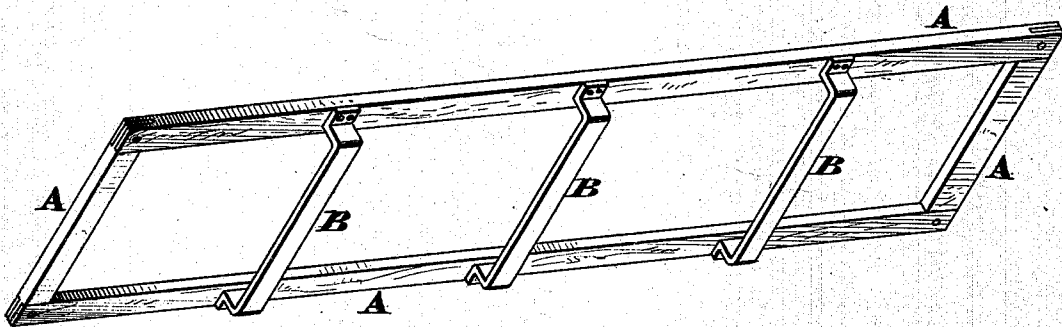

Fig. 2.

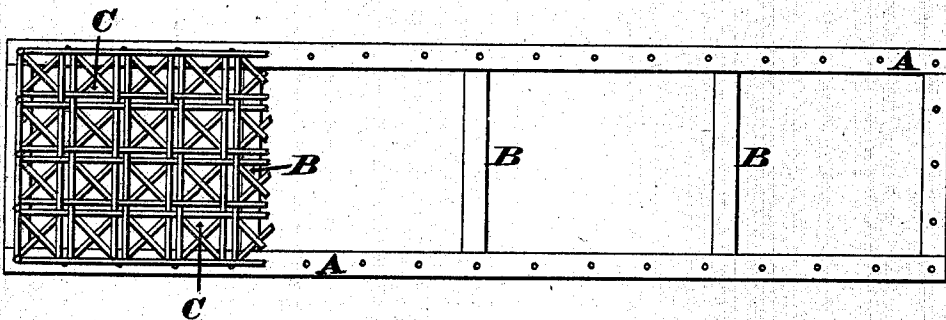

Fig. 3.



Attest.
Jas. H. Layman,
Walter Allen

Francis Farrell
By Knight Bros.

Attys.

UNITED STATES PATENT OFFICE.

FRANCIS FARRELL, OF CINCINNATI, OHIO, ASSIGNOR TO HIMSELF AND ASA J. NICHOLS, OF SAME PLACE.

IMPROVEMENT IN CAR-SEATS.

Specification forming part of Letters Patent No. 139,561, dated June 3, 1873; application filed April 16, 1873.

To all whom it may concern:

Be it known that I, FRANCIS FARRELL, of Cincinnati, Hamilton county, Ohio, have invented a new and useful Bottom for Car and other Seats, of which the following is a specification:

My invention is designed to provide a light, salubrious, and portable ventilating bottom for the seats of street-cars and other public vehicles, to take the place of the customary filthy and contagious plush or cloth cushion.

My improved seat-bottom consists essentially of an oblong rectangular wooden frame, stayed on its under side with transverse depressed metallic bars, and mounted with a cane web or filling.

Figure 1 is a perspective view of the frame of my seat-bottom, having its depressed metallic stays attached. Fig. 2 is a top view of the same in its complete form, with the exception of a portion of the cane-webbing. Fig. 3 is a transverse section of said bottom.

A represents an oblong rectangular frame, preferably of ash, or other light, hard, and tough wood. Attached to the under side of this frame are metallic bars or stays B, which serve to stiffen the frame and to prevent the collapse or bending together of the necessarily long front and back rails of said frame by

continued use; the represented depressed form of said bars removing their upper surfaces from any liability by contact with the cane to interfere with the temporary sag of said webbing under heavy occupants or of causing uncomfortable ridges to be formed.

It will be seen that my seat-bottom is complete in itself, and that it can be packed in a very small compass for stowage or transportation; that it can be manufactured quite cheaply of various sizes, so as to be readily substituted in summer time for the ordinary dirty, hot, and infectious cushion now of almost universal use in street-cars and other public conveyances; and that, in such cases, it will only be necessary to lift out the old cushion, and to drop in one of my improved seat-bottoms, which will be the labor of but a few moments.

I claim as a new article of manufacture—

The car-seat bottom, composed of the oblong rectangular frame A, depressed stays B, and cane-web C, as represented.

In testimony of which invention I hereunto set my hand.

FRANCIS FARRELL.

Attest:

GEO. H. KNIGHT,
H. SCHOONMAKER.