



(51) International Patent Classification:  
H04L 1/18 (2006.01)

(21) International Application Number:  
PCT/CN2018/082064

(22) International Filing Date:  
05 April 2018 (05.04.2018)

(25) Filing Language: English

(26) Publication Language: English

(71) Applicant: **QUALCOMM INCORPORATED** [US/US];  
c/o International IP Administration, 5775 Morehouse Drive,  
San Diego, California 92121-1714 (US).

(72) Inventors; and

(71) Applicants (for US only): **WU, Liangming** [CN/CN];  
5775 Morehouse Drive, San Diego, California 92121-1714  
(US). **ZHANG, Yu** [CN/CN]; 5775 Morehouse Drive,  
San Diego, California 92121-1714 (US). **HUANG, Yi**  
[CN/US]; 5775 Morehouse Drive, San Diego, California  
92121-1714 (US). **HAO, Chenxi** [CN/CN]; 5775 More-  
house Drive, San Diego, California 92121-1714 (US).  
**CHEN, Wanshi** [CN/US]; 5775 Morehouse Drive, San  
Diego, California 92121-1714 (US).

(74) Agent: **NTD PATENT & TRADEMARK AGENCY LIMITED**; 10th Floor, Tower C, Beijing Global Trade Center, 36 North Third Ring Road East, Dongcheng District, Beijing 100013 (CN).

(81) Designated States (unless otherwise indicated, for every kind of national protection available): AE, AG, AL, AM, AO, AT, AU, AZ, BA, BB, BG, BH, BN, BR, BW, BY, BZ, CA, CH, CL, CN, CO, CR, CU, CZ, DE, DJ, DK, DM, DO, DZ, EC, EE, EG, ES, FI, GB, GD, GE, GH, GM, GT, HN, HR, HU, ID, IL, IN, IR, IS, JO, JP, KE, KG, KH, KN, KP, KR, KW, KZ, LA, LC, LK, LR, LS, LU, LY, MA, MD, ME, MG, MK, MN, MW, MX, MY, MZ, NA, NG, NI, NO, NZ, OM, PA, PE, PG, PH, PL, PT, QA, RO, RS, RU, RW, SA, SC, SD, SE, SG, SK, SL, SM, ST, SV, SY, TH, TJ, TM, TN, TR, TT, TZ, UA, UG, US, UZ, VC, VN, ZA, ZM, ZW.

(84) Designated States (unless otherwise indicated, for every kind of regional protection available): ARIPO (BW, GH, GM, KE, LR, LS, MW, MZ, NA, RW, SD, SL, ST, SZ, TZ, UG, ZM, ZW), Eurasian (AM, AZ, BY, KG, KZ, RU, TJ, TM), European (AL, AT, BE, BG, CH, CY, CZ, DE, DK, EE, ES, FI, FR, GB, GR, HR, HU, IE, IS, IT, LT, LU, LV, MC, MK, MT, NL, NO, PL, PT, RO, RS, SE, SI, SK, SM, TR), OAPI (BF, BJ, CF, CG, CI, CM, GA, GN, GQ, GW, KM, ML, MR, NE, SN, TD, TG).

(54) Title: COLLISION HANDLING FOR CSI REPORTING ON PUSCH

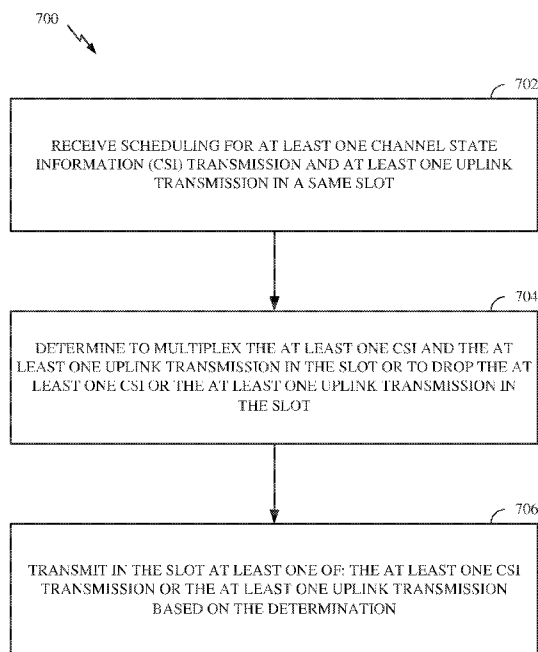

FIG. 7

(57) Abstract: Certain aspects of the present disclosure provide techniques for collision handling for channel state information (CSI) reporting on a physical uplink shared channel (PUSCH). A method for wireless communications by a user equipment (UE) is provided. The method generally includes receiving scheduling for at least one CSI transmission and at least one uplink transmission in a same slot. The UE determines to multiplex the at least one CSI and the at least one uplink transmission in the slot or to drop the at least one CSI or the at least one uplink transmission in the slot. The UE transmits in the slot at least one of: the at least one CSI transmission or the at least one uplink transmission based on the determination. A base station (BS) can schedule CSI and scheduling requests (SRs) in non-overlapping slots, such as the CSI and SR do not collide.



**Declarations under Rule 4.17:**

— *of inventorship (Rule 4.17(iv))*

**Published:**

— *with international search report (Art. 21(3))*

## COLLISION HANDLING FOR CSI REPORTING ON PUSCH

### INTRODUCTION

#### Field of the Disclosure

[0001] Aspects of the present disclosure relate to wireless communications, and more particularly, to techniques for collision handling for channel state information (CSI) reporting on the physical uplink shared channel (PUSCH).

#### Description of Related Art

[0002] Wireless communication systems are widely deployed to provide various telecommunication services such as telephony, video, data, messaging, broadcasts, etc. These wireless communication systems may employ multiple-access technologies capable of supporting communication with multiple users by sharing available system resources (e.g., bandwidth, transmit power, etc.). Examples of such multiple-access systems include 3rd Generation Partnership Project (3GPP) Long Term Evolution (LTE) systems, LTE Advanced (LTE-A) systems, code division multiple access (CDMA) systems, time division multiple access (TDMA) systems, frequency division multiple access (FDMA) systems, orthogonal frequency division multiple access (OFDMA) systems, single-carrier frequency division multiple access (SC-FDMA) systems, and time division synchronous code division multiple access (TD-SCDMA) systems, to name a few.

[0003] In some examples, a wireless multiple-access communication system may include a number of base stations (BSs), which are each capable of simultaneously supporting communication for multiple communication devices, otherwise known as user equipments (UEs). In an LTE or LTE-A network, a set of one or more base stations may define an eNodeB (eNB). In other examples (e.g., in a next generation, a new radio (NR), or 5G network), a wireless multiple access communication system may include a number of distributed units (DUs) (e.g., edge units (EUs), edge nodes (ENs), radio heads (RHs), smart radio heads (SRHs), transmission reception points (TRPs), etc.) in communication with a number of central units (CUs) (e.g., central nodes (CNs), access node controllers (ANCs), etc.), where a set of one or more distributed units, in communication with a central unit, may define an access node (e.g., which may be referred to as a base station, 5G NB, next generation NodeB (gNB or gNodeB), TRP,

etc.). A base station or distributed unit may communicate with a set of UEs on downlink channels (e.g., for transmissions from a base station or to a UE) and uplink channels (e.g., for transmissions from a UE to a base station or distributed unit).

[0004] These multiple access technologies have been adopted in various telecommunication standards to provide a common protocol that enables different wireless devices to communicate on a municipal, national, regional, and even global level. New Radio (NR) (e.g., 5G) is an example of an emerging telecommunication standard. NR is a set of enhancements to the LTE mobile standard promulgated by 3GPP. It is designed to better support mobile broadband Internet access by improving spectral efficiency, lowering costs, improving services, making use of new spectrum, and better integrating with other open standards using OFDMA with a cyclic prefix (CP) on the downlink (DL) and on the uplink (UL). To these ends, NR supports beamforming, multiple-input multiple-output (MIMO) antenna technology, and carrier aggregation.

[0005] However, as the demand for mobile broadband access continues to increase, there exists a need for further improvements in NR and LTE technology. Preferably, these improvements should be applicable to other multi-access technologies and the telecommunication standards that employ these technologies.

### **BRIEF SUMMARY**

[0006] The systems, methods, and devices of the disclosure each have several aspects, no single one of which is solely responsible for its desirable attributes. Without limiting the scope of this disclosure as expressed by the claims which follow, some features will now be discussed briefly. After considering this discussion, and particularly after reading the section entitled "Detailed Description" one will understand how the features of this disclosure provide advantages that include improved communications between access points and stations in a wireless network.

[0007] Aspects of the present disclosure relate to collision handling for channel state information (CSI) reporting on the physical uplink shared channel (PUSCH).

[0008] Certain aspects provide a method for wireless communication by a user equipment (UE). The method generally includes receiving scheduling for at least one CSI transmission and at least one uplink transmission in a same slot. The method includes determining to multiplex the at least one CSI and the at least one uplink

transmission in the slot or to drop the at least one CSI or the at least one uplink transmission in the slot. The method includes transmitting in the slot at least one of: the at least one CSI transmission or the at least one uplink transmission based on the determination.

[0009] Certain aspects provide a method for wireless communication by a base station (BS). The method generally includes scheduling a UE to transmit scheduling requests (SRs) in a first set of slots and to transmit CSI in a second set of slots that is non-overlapping with the first set of slots. The method includes receiving SRs in the first set of slots and CSI in the second set of slots.

[0010] Certain aspects of the present disclosure provide means, apparatus, and computer readable media for performing techniques described herein for collision handling of CSI on PUSCH.

[0011] To the accomplishment of the foregoing and related ends, the one or more aspects comprise the features hereinafter fully described and particularly pointed out in the claims. The following description and the appended drawings set forth in detail certain illustrative features of the one or more aspects. These features are indicative, however, of but a few of the various ways in which the principles of various aspects may be employed.

### BRIEF DESCRIPTION OF THE DRAWINGS

[0012] So that the manner in which the above-recited features of the present disclosure can be understood in detail, a more particular description, briefly summarized above, may be had by reference to aspects, some of which are illustrated in the drawings. It is to be noted, however, that the appended drawings illustrate only certain typical aspects of this disclosure and are therefore not to be considered limiting of its scope, for the description may admit to other equally effective aspects.

[0013] **FIG. 1** is a block diagram conceptually illustrating an example telecommunications system, in accordance with certain aspects of the present disclosure.

[0014] **FIG. 2** is a block diagram illustrating an example logical architecture of a distributed radio access network (RAN), in accordance with certain aspects of the present disclosure.

[0015] FIG. 3 is a diagram illustrating an example physical architecture of a distributed RAN, in accordance with certain aspects of the present disclosure.

[0016] FIG. 4 is a block diagram conceptually illustrating a design of an example base station (BS) and user equipment (UE), in accordance with certain aspects of the present disclosure.

[0017] FIG. 5 is a diagram showing examples for implementing a communication protocol stack, in accordance with certain aspects of the present disclosure.

[0018] FIG. 6 illustrates an example of a frame format for a new radio (NR) system, in accordance with certain aspects of the present disclosure.

[0019] FIG. 7 is a flow diagram illustrating example operations for wireless communications by a UE, in accordance with certain aspects of the present disclosure.

[0020] FIG. 8 is an example collision of semi-persistent channel state information (SP-CSI) and uplink data in a slot, in accordance with certain aspects of the present disclosure.

[0021] FIG. 9 is an example collision of SP-CSI and uplink data in overlapping symbols in a slot, in accordance with certain aspects of the present disclosure.

[0022] FIG. 10 is an example of SP-CSI transmitted before uplink data in a slot, in accordance with certain aspects of the present disclosure.

[0023] FIG. 11 is a flow diagram illustrating example operations for wireless communications by a BS, in accordance with certain aspects of the present disclosure.

[0024] FIG. 12 illustrates a communications device that may include various components configured to perform operations for the techniques disclosed herein in accordance with aspects of the present disclosure.

[0025] FIG. 13 illustrates another communications device that may include various components configured to perform operations for the techniques disclosed herein in accordance with aspects of the present disclosure.

[0026] To facilitate understanding, identical reference numerals have been used, where possible, to designate identical elements that are common to the figures. It is

contemplated that elements disclosed in one aspect may be beneficially utilized on other aspects without specific recitation.

### DETAILED DESCRIPTION

[0027] Aspects of the present disclosure provide apparatus, methods, processing systems, and computer readable mediums for collision handling for channel state information (CSI) reporting on the physical uplink shared channel (PUSCH).

[0028] In certain systems, user equipment (UE) are configured for semi-persistent (SP) CSI transmission on the PUSCH. The UEs can also transmit aperiodic CSI on the PUSCH. The UEs may also be scheduled for other uplink transmissions that can occur in the same slot (e.g., collide) as the SP-CSI and/or A-CSI transmissions in the slot. For example, the UE may have data to transmit in the PUSCH and/or scheduling requests (SRs), buffer status reports (BSRs), and/or hybrid automatic repeat request (HARQ) feedback to transmit in a physical uplink control channel (PUCCH) in the same slot. Thus, collision handling is needed for CSI and data in the same PUSCH. Further, UEs may not transmit PUSCH and PUCCH in the same slot and, therefore, collision handling is needed for CSI in the PUSCH and SR, BSR, and/or HARQ feedback in a PUCCH in the same slot.

[0029] Accordingly, aspects of the present disclosure provide collision handling for CSI on the PUSCH and other uplink transmissions scheduled in the same slot.

[0030] The following description provides examples, and is not limiting of the scope, applicability, or examples set forth in the claims. Changes may be made in the function and arrangement of elements discussed without departing from the scope of the disclosure. Various examples may omit, substitute, or add various procedures or components as appropriate. For instance, the methods described may be performed in an order different from that described, and various steps may be added, omitted, or combined. Also, features described with respect to some examples may be combined in some other examples. For example, an apparatus may be implemented or a method may be practiced using any number of the aspects set forth herein. In addition, the scope of the disclosure is intended to cover such an apparatus or method which is practiced using other structure, functionality, or structure and functionality in addition to, or other than, the various aspects of the disclosure set forth herein. It should be understood that any

aspect of the disclosure disclosed herein may be embodied by one or more elements of a claim. The word “exemplary” is used herein to mean “serving as an example, instance, or illustration.” Any aspect described herein as “exemplary” is not necessarily to be construed as preferred or advantageous over other aspects.

[0031] The techniques described herein may be used for various wireless communication technologies, such as LTE, CDMA, TDMA, FDMA, OFDMA, SC-FDMA and other networks. The terms “network” and “system” are often used interchangeably. A CDMA network may implement a radio technology such as Universal Terrestrial Radio Access (UTRA), cdma2000, etc. UTRA includes Wideband CDMA (WCDMA) and other variants of CDMA. cdma2000 covers IS-2000, IS-95 and IS-856 standards. A TDMA network may implement a radio technology such as Global System for Mobile Communications (GSM). An OFDMA network may implement a radio technology such as NR (e.g. 5G RA), Evolved UTRA (E-UTRA), Ultra Mobile Broadband (UMB), IEEE 802.11 (Wi-Fi), IEEE 802.16 (WiMAX), IEEE 802.20, Flash-OFDMA, etc. UTRA and E-UTRA are part of Universal Mobile Telecommunication System (UMTS).

[0032] New Radio (NR) is an emerging wireless communications technology under development in conjunction with the 5G Technology Forum (5GTF). 3GPP Long Term Evolution (LTE) and LTE-Advanced (LTE-A) are releases of UMTS that use E-UTRA. UTRA, E-UTRA, UMTS, LTE, LTE-A and GSM are described in documents from an organization named “3rd Generation Partnership Project” (3GPP). cdma2000 and UMB are described in documents from an organization named “3rd Generation Partnership Project 2” (3GPP2). The techniques described herein may be used for the wireless networks and radio technologies mentioned above as well as other wireless networks and radio technologies. For clarity, while aspects may be described herein using terminology commonly associated with 3G and/or 4G wireless technologies, aspects of the present disclosure can be applied in other generation-based communication systems, such as 5G and later, including NR technologies.

[0033] New radio (NR) access (e.g., 5G technology) may support various wireless communication services, such as enhanced mobile broadband (eMBB) targeting wide bandwidth (e.g., 80 MHz or beyond), millimeter wave (mmW) targeting high carrier frequency (e.g., 25 GHz or beyond), massive machine type communications MTC

(mMTC) targeting non-backward compatible MTC techniques, and/or mission critical targeting ultra-reliable low-latency communications (URLLC). These services may include latency and reliability requirements. These services may also have different transmission time intervals (TTI) to meet respective quality of service (QoS) requirements. In addition, these services may co-exist in the same subframe.

*Example Wireless Communications System*

[0034] FIG. 1 illustrates an example wireless communication network 100 in which aspects of the present disclosure may be performed. For example, the wireless communication network 100 may be a New Radio (NR) or 5G network. A UE 120 is scheduled (e.g., signaled and/or configured) for a channel state information (CSI) transmission, such as semi-periodic (SP) CSI or aperiodic CSI (A-CSI), in a slot. The UE 120 is also scheduled (e.g., signaled and/or configured) for an uplink transmission (e.g., a scheduling request (SR), buffer status report (BSR), hybrid automatic repeat request (HARQ) feedback, and/or data) in the same slot. The UE 120 determines to multiplex or drop the CSI and another uplink transmission and transmits in the slot in accordance with the determination. In another example, a BS 110 schedules CSI and SR such that they do not collide.

[0035] As illustrated in FIG. 1, the wireless communication network 100 may include a number of base stations (BSs) 110 and other network entities. A BS may be a station that communicates with user equipments (UEs). Each BS 110 may provide communication coverage for a particular geographic area. In 3GPP, the term “cell” can refer to a coverage area of a Node B (NB) and/or a Node B subsystem serving this coverage area, depending on the context in which the term is used. In NR systems, the term “cell” and next generation NodeB (gNB), new radio base station (NR BS), 5G NB, access point (AP), or transmission reception point (TRP) may be interchangeable. In some examples, a cell may not necessarily be stationary, and the geographic area of the cell may move according to the location of a mobile BS. In some examples, the base stations may be interconnected to one another and/or to one or more other base stations or network nodes (not shown) in wireless communication network 100 through various types of backhaul interfaces, such as a direct physical connection, a wireless connection, a virtual network, or the like using any suitable transport network.

[0036] In general, any number of wireless networks may be deployed in a given geographic area. Each wireless network may support a particular radio access technology (RAT) and may operate on one or more frequencies. A RAT may also be referred to as a radio technology, an air interface, etc. A frequency may also be referred to as a carrier, a subcarrier, a frequency channel, a tone, a subband, etc. Each frequency may support a single RAT in a given geographic area in order to avoid interference between wireless networks of different RATs. In some cases, NR or 5G RAT networks may be deployed.

[0037] A base station (BS) may provide communication coverage for a macro cell, a pico cell, a femto cell, and/or other types of cells. A macro cell may cover a relatively large geographic area (e.g., several kilometers in radius) and may allow unrestricted access by UEs with service subscription. A pico cell may cover a relatively small geographic area and may allow unrestricted access by UEs with service subscription. A femto cell may cover a relatively small geographic area (e.g., a home) and may allow restricted access by UEs having an association with the femto cell (e.g., UEs in a Closed Subscriber Group (CSG), UEs for users in the home, etc.). A BS for a macro cell may be referred to as a macro BS. A BS for a pico cell may be referred to as a pico BS. A BS for a femto cell may be referred to as a femto BS or a home BS. In the example shown in **FIG. 1**, the BSs 110a, 110b and 110c may be macro BSs for the macro cells 102a, 102b and 102c, respectively. The BS 110x may be a pico BS for a pico cell 102x. The BSs 110y and 110z may be femto BSs for the femto cells 102y and 102z, respectively. A BS may support one or multiple (e.g., three) cells.

[0038] Wireless communication network 100 may also include relay stations. A relay station is a station that receives a transmission of data and/or other information from an upstream station (e.g., a BS or a UE) and sends a transmission of the data and/or other information to a downstream station (e.g., a UE or a BS). A relay station may also be a UE that relays transmissions for other UEs. In the example shown in **FIG. 1**, a relay station 110r may communicate with the BS 110a and a UE 120r in order to facilitate communication between the BS 110a and the UE 120r. A relay station may also be referred to as a relay BS, a relay, etc.

[0039] Wireless communication network 100 may be a heterogeneous network that includes BSs of different types, e.g., macro BS, pico BS, femto BS, relays, etc. These

different types of BSs may have different transmit power levels, different coverage areas, and different impact on interference in the wireless communication network 100. For example, macro BS may have a high transmit power level (e.g., 20 Watts) whereas pico BS, femto BS, and relays may have a lower transmit power level (e.g., 1 Watt).

[0040] Wireless communication network 100 may support synchronous or asynchronous operation. For synchronous operation, the BSs may have similar frame timing, and transmissions from different BSs may be approximately aligned in time. For asynchronous operation, the BSs may have different frame timing, and transmissions from different BSs may not be aligned in time. The techniques described herein may be used for both synchronous and asynchronous operation.

[0041] A network controller 130 may couple to a set of BSs and provide coordination and control for these BSs. The network controller 130 may communicate with the BSs 110 via a backhaul. The BSs 110 may also communicate with one another (e.g., directly or indirectly) via wireless or wireline backhaul.

[0042] The UEs 120 (e.g., 120x, 120y, etc.) may be dispersed throughout the wireless communication network 100, and each UE may be stationary or mobile. A UE may also be referred to as a mobile station, a terminal, an access terminal, a subscriber unit, a station, a Customer Premises Equipment (CPE), a cellular phone, a smart phone, a personal digital assistant (PDA), a wireless modem, a wireless communication device, a handheld device, a laptop computer, a cordless phone, a wireless local loop (WLL) station, a tablet computer, a camera, a gaming device, a netbook, a smartbook, an ultrabook, an appliance, a medical device or medical equipment, a biometric sensor/device, a wearable device such as a smart watch, smart clothing, smart glasses, a smart wrist band, smart jewelry (e.g., a smart ring, a smart bracelet, etc.), an entertainment device (e.g., a music device, a video device, a satellite radio, etc.), a vehicular component or sensor, a smart meter/sensor, industrial manufacturing equipment, a global positioning system device, or any other suitable device that is configured to communicate via a wireless or wired medium. Some UEs may be considered machine-type communication (MTC) devices or evolved MTC (eMTC) devices. MTC and eMTC UEs include, for example, robots, drones, remote devices, sensors, meters, monitors, location tags, etc., that may communicate with a BS, another device (e.g., remote device), or some other entity. A wireless node may provide, for

example, connectivity for or to a network (e.g., a wide area network such as Internet or a cellular network) via a wired or wireless communication link. Some UEs may be considered Internet-of-Things (IoT) devices, which may be narrowband IoT (NB-IoT) devices.

[0043] Certain wireless networks (e.g., LTE) utilize orthogonal frequency division multiplexing (OFDM) on the downlink and single-carrier frequency division multiplexing (SC-FDM) on the uplink. OFDM and SC-FDM partition the system bandwidth into multiple ( $K$ ) orthogonal subcarriers, which are also commonly referred to as tones, bins, etc. Each subcarrier may be modulated with data. In general, modulation symbols are sent in the frequency domain with OFDM and in the time domain with SC-FDM. The spacing between adjacent subcarriers may be fixed, and the total number of subcarriers ( $K$ ) may be dependent on the system bandwidth. For example, the spacing of the subcarriers may be 15 kHz and the minimum resource allocation (called a “resource block” (RB)) may be 12 subcarriers (or 180 kHz). Consequently, the nominal Fast Fourier Transfer (FFT) size may be equal to 128, 256, 512, 1024 or 2048 for system bandwidth of 1.25, 2.5, 5, 10, or 20 megahertz (MHz), respectively. The system bandwidth may also be partitioned into subbands. For example, a subband may cover 1.08 MHz (i.e., 6 resource blocks), and there may be 1, 2, 4, 8, or 16 subbands for system bandwidth of 1.25, 2.5, 5, 10 or 20 MHz, respectively.

[0044] While aspects of the examples described herein may be associated with LTE technologies, aspects of the present disclosure may be applicable with other wireless communications systems, such as NR. NR may utilize OFDM with a CP on the uplink and downlink and include support for half-duplex operation using TDD. Beamforming may be supported and beam direction may be dynamically configured. MIMO transmissions with precoding may also be supported. MIMO configurations in the DL may support up to 8 transmit antennas with multi-layer DL transmissions up to 8 streams and up to 2 streams per UE. Multi-layer transmissions with up to 2 streams per UE may be supported. Aggregation of multiple cells may be supported with up to 8 serving cells.

[0045] In some examples, access to the air interface may be scheduled, wherein a scheduling entity (e.g., a base station) allocates resources for communication among some or all devices and equipment within its service area or cell. The scheduling entity

may be responsible for scheduling, assigning, reconfiguring, and releasing resources for one or more subordinate entities. That is, for scheduled communication, subordinate entities utilize resources allocated by the scheduling entity. Base stations are not the only entities that may function as a scheduling entity. In some examples, a UE may function as a scheduling entity and may schedule resources for one or more subordinate entities (e.g., one or more other UEs), and the other UEs may utilize the resources scheduled by the UE for wireless communication. In some examples, a UE may function as a scheduling entity in a peer-to-peer (P2P) network, and/or in a mesh network. In a mesh network example, UEs may communicate directly with one another in addition to communicating with a scheduling entity.

[0046] In **FIG. 1**, a solid line with double arrows indicates desired transmissions between a UE and a serving BS, which is a BS designated to serve the UE on the downlink and/or uplink. A finely dashed line with double arrows indicates interfering transmissions between a UE and a BS.

[0047] **FIG. 2** illustrates an example logical architecture of a distributed Radio Access Network (RAN) 200, which may be implemented in the wireless communication network 100 illustrated in **FIG. 1**. A 5G access node 206 may include an access node controller (ANC) 202. ANC 202 may be a central unit (CU) of the distributed RAN 200. The backhaul interface to the Next Generation Core Network (NG-CN) 204 may terminate at ANC 202. The backhaul interface to neighboring next generation access Nodes (NG-ANs) 210 may terminate at ANC 202. ANC 202 may include one or more transmission reception points (TRPs) 208 (e.g., cells, BSs, gNBs, etc.).

[0048] The TRPs 208 may be a distributed unit (DU). TRPs 208 may be connected to a single ANC (e.g., ANC 202) or more than one ANC (not illustrated). For example, for RAN sharing, radio as a service (RaaS), and service specific AND deployments, TRPs 208 may be connected to more than one ANC. TRPs 208 may each include one or more antenna ports. TRPs 208 may be configured to individually (e.g., dynamic selection) or jointly (e.g., joint transmission) serve traffic to a UE.

[0049] The logical architecture of distributed RAN 200 may support fronthauling solutions across different deployment types. For example, the logical architecture may be based on transmit network capabilities (e.g., bandwidth, latency, and/or jitter).

[0050] The logical architecture of distributed RAN 200 may share features and/or components with LTE. For example, next generation access node (NG-AN) 210 may support dual connectivity with NR and may share a common fronthaul for LTE and NR.

[0051] The logical architecture of distributed RAN 200 may enable cooperation between and among TRPs 208, for example, within a TRP and/or across TRPs via ANC 202. An inter-TRP interface may not be used.

[0052] Logical functions may be dynamically distributed in the logical architecture of distributed RAN 200. As will be described in more detail with reference to **FIG. 5**, the Radio Resource Control (RRC) layer, Packet Data Convergence Protocol (PDCP) layer, Radio Link Control (RLC) layer, Medium Access Control (MAC) layer, and a Physical (PHY) layers may be adaptably placed at the DU (e.g., TRP 208) or CU (e.g., ANC 202).

[0053] **FIG. 3** illustrates an example physical architecture of a distributed Radio Access Network (RAN) 300, according to aspects of the present disclosure. A centralized core network unit (C-CU) 302 may host core network functions. C-CU 302 may be centrally deployed. C-CU 302 functionality may be offloaded (e.g., to advanced wireless services (AWS)), in an effort to handle peak capacity.

[0054] A centralized RAN unit (C-RU) 304 may host one or more ANC functions. Optionally, the C-RU 304 may host core network functions locally. The C-RU 304 may have distributed deployment. The C-RU 304 may be close to the network edge.

[0055] A DU 306 may host one or more TRPs (Edge Node (EN), an Edge Unit (EU), a Radio Head (RH), a Smart Radio Head (SRH), or the like). The DU may be located at edges of the network with radio frequency (RF) functionality.

[0056] **FIG. 4** illustrates example components of BS 110 and UE 120 (as depicted in **FIG. 1**), which may be used to implement aspects of the present disclosure. For example, antennas 452, processors 466, 458, 464, and/or controller/processor 480 of the UE 120 and/or antennas 434, processors 420, 460, 438, and/or controller/processor 440 of the BS 110 may be used to perform the various techniques and methods described herein for CSI collision handling for PUSCH.

[0057] At the BS 110, a transmit processor 420 may receive data from a data source 412 and control information from a controller/processor 440. The control information

may be for the physical broadcast channel (PBCH), physical control format indicator channel (PCFICH), physical hybrid ARQ indicator channel (PHICH), physical downlink control channel (PDCCH), group common PDCCH (GC PDCCH), etc. The data may be for the physical downlink shared channel (PDSCH), etc. The processor 420 may process (e.g., encode and symbol map) the data and control information to obtain data symbols and control symbols, respectively. The processor 420 may also generate reference symbols, e.g., for the primary synchronization signal (PSS), secondary synchronization signal (SSS), and cell-specific reference signal (CRS). A transmit (TX) multiple-input multiple-output (MIMO) processor 430 may perform spatial processing (e.g., precoding) on the data symbols, the control symbols, and/or the reference symbols, if applicable, and may provide output symbol streams to the modulators (MODs) 432a through 432t. Each modulator 432 may process a respective output symbol stream (e.g., for OFDM, etc.) to obtain an output sample stream. Each modulator may further process (e.g., convert to analog, amplify, filter, and upconvert) the output sample stream to obtain a downlink signal. Downlink signals from modulators 432a through 432t may be transmitted via the antennas 434a through 434t, respectively.

**[0058]** At the UE 120, the antennas 452a through 452r may receive the downlink signals from the base station 110 and may provide received signals to the demodulators (DEMODs) in transceivers 454a through 454r, respectively. Each demodulator 454 may condition (e.g., filter, amplify, downconvert, and digitize) a respective received signal to obtain input samples. Each demodulator may further process the input samples (e.g., for OFDM, etc.) to obtain received symbols. A MIMO detector 456 may obtain received symbols from all the demodulators 454a through 454r, perform MIMO detection on the received symbols if applicable, and provide detected symbols. A receive processor 458 may process (e.g., demodulate, deinterleave, and decode) the detected symbols, provide decoded data for the UE 120 to a data sink 460, and provide decoded control information to a controller/processor 480.

**[0059]** On the uplink, at UE 120, a transmit processor 464 may receive and process data (e.g., for the physical uplink shared channel (PUSCH)) from a data source 462 and control information (e.g., for the physical uplink control channel (PUCCH)) from the controller/processor 480. The transmit processor 464 may also generate reference symbols for a reference signal (e.g., for the sounding reference signal (SRS)). The

symbols from the transmit processor 464 may be precoded by a TX MIMO processor 466 if applicable, further processed by the demodulators in transceivers 454a through 454r (e.g., for SC-FDM, etc.), and transmitted to the base station 110. At the BS 110, the uplink signals from the UE 120 may be received by the antennas 434, processed by the modulators 432, detected by a MIMO detector 436 if applicable, and further processed by a receive processor 438 to obtain decoded data and control information sent by the UE 120. The receive processor 438 may provide the decoded data to a data sink 439 and the decoded control information to the controller/processor 440.

[0060] The controllers/processors 440 and 480 may direct the operation at the base station 110 and the UE 120, respectively. The processor 440 and/or other processors and modules at the BS 110 may perform or direct the execution of processes for the techniques described herein. The memories 442 and 482 may store data and program codes for BS 110 and UE 120, respectively. A scheduler 444 may schedule UEs for data transmission on the downlink and/or uplink.

[0061] **FIG. 5** illustrates a diagram 500 showing examples for implementing a communications protocol stack, according to aspects of the present disclosure. The illustrated communications protocol stacks may be implemented by devices operating in a wireless communication system, such as a 5G system (e.g., a system that supports uplink-based mobility). Diagram 500 illustrates a communications protocol stack including a Radio Resource Control (RRC) layer 510, a Packet Data Convergence Protocol (PDCP) layer 515, a Radio Link Control (RLC) layer 520, a Medium Access Control (MAC) layer 525, and a Physical (PHY) layer 530. In various examples, the layers of a protocol stack may be implemented as separate modules of software, portions of a processor or ASIC, portions of non-collocated devices connected by a communications link, or various combinations thereof. Collocated and non-collocated implementations may be used, for example, in a protocol stack for a network access device (e.g., ANs, CUs, and/or DUs) or a UE.

[0062] A first option 505-a shows a split implementation of a protocol stack, in which implementation of the protocol stack is split between a centralized network access device (e.g., an ANC 202 in **FIG. 2**) and distributed network access device (e.g., DU 208 in **FIG. 2**). In the first option 505-a, an RRC layer 510 and a PDCP layer 515 may be implemented by the central unit, and an RLC layer 520, a MAC layer 525,

and a PHY layer 530 may be implemented by the DU. In various examples the CU and the DU may be collocated or non-collocated. The first option 505-a may be useful in a macro cell, micro cell, or pico cell deployment.

[0063] A second option 505-b shows a unified implementation of a protocol stack, in which the protocol stack is implemented in a single network access device. In the second option, RRC layer 510, PDCP layer 515, RLC layer 520, MAC layer 525, and PHY layer 530 may each be implemented by the AN. The second option 505-b may be useful in, for example, a femto cell deployment.

[0064] Regardless of whether a network access device implements part or all of a protocol stack, a UE may implement an entire protocol stack as shown in 505-c (e.g., the RRC layer 510, the PDCP layer 515, the RLC layer 520, the MAC layer 525, and the PHY layer 530).

[0065] In LTE, the basic transmission time interval (TTI) or packet duration is the 1 ms subframe. In NR, a subframe is still 1 ms, but the basic TTI is referred to as a slot. A subframe contains a variable number of slots (e.g., 1, 2, 4, 8, 16, ... slots) depending on the subcarrier spacing. The NR RB is 12 consecutive frequency subcarriers. NR may support a base subcarrier spacing of 15 KHz and other subcarrier spacing may be defined with respect to the base subcarrier spacing, for example, 30 kHz, 60 kHz, 120 kHz, 240 kHz, etc. The symbol and slot lengths scale with the subcarrier spacing. The CP length also depends on the subcarrier spacing.

[0066] FIG. 6 is a diagram showing an example of a frame format 600 for NR. The transmission timeline for each of the downlink and uplink may be partitioned into units of radio frames. Each radio frame may have a predetermined duration (e.g., 10 ms) and may be partitioned into 10 subframes, each of 1 ms, with indices of 0 through 9. Each subframe may include a variable number of slots depending on the subcarrier spacing. Each slot may include a variable number of symbol periods (e.g., 7 or 14 symbols) depending on the subcarrier spacing. The symbol periods in each slot may be assigned indices. A mini-slot is a subslot structure (e.g., 2, 3, or 4 symbols).

[0067] Each symbol in a slot may indicate a link direction (e.g., DL, UL, or flexible) for data transmission and the link direction for each subframe may be dynamically

switched. The link directions may be based on the slot format. Each slot may include DL/UL data as well as DL/UL control information.

**[0068]** In NR, a synchronization signal (SS) block is transmitted. The SS block includes a PSS, a SSS, and a two symbol PBCH. The SS block can be transmitted in a fixed slot location, such as the symbols 0-3 as shown in **FIG. 6**. The PSS and SSS may be used by UEs for cell search and acquisition. The PSS may provide half-frame timing, the SS may provide the CP length and frame timing. The PSS and SSS may provide the cell identity. The PBCH carries some basic system information, such as downlink system bandwidth, timing information within radio frame, SS burst set periodicity, system frame number, etc. The SS blocks may be organized into SS bursts to support beam sweeping. Further system information such as, remaining minimum system information (RMSI), system information blocks (SIBs), other system information (OSI) can be transmitted on a physical downlink shared channel (PDSCH) in certain subframes.

**[0069]** In some circumstances, two or more subordinate entities (e.g., UEs) may communicate with each other using sidelink signals. Real-world applications of such sidelink communications may include public safety, proximity services, UE-to-network relaying, vehicle-to-vehicle (V2V) communications, Internet of Everything (IoE) communications, IoT communications, mission-critical mesh, and/or various other suitable applications. Generally, a sidelink signal may refer to a signal communicated from one subordinate entity (e.g., UE1) to another subordinate entity (e.g., UE2) without relaying that communication through the scheduling entity (e.g., UE or BS), even though the scheduling entity may be utilized for scheduling and/or control purposes. In some examples, the sidelink signals may be communicated using a licensed spectrum (unlike wireless local area networks, which typically use an unlicensed spectrum).

**[0070]** A UE may operate in various radio resource configurations, including a configuration associated with transmitting pilots using a dedicated set of resources (e.g., a radio resource control (RRC) dedicated state, etc.) or a configuration associated with transmitting pilots using a common set of resources (e.g., an RRC common state, etc.). When operating in the RRC dedicated state, the UE may select a dedicated set of resources for transmitting a pilot signal to a network. When operating in the RRC

common state, the UE may select a common set of resources for transmitting a pilot signal to the network. In either case, a pilot signal transmitted by the UE may be received by one or more network access devices, such as an AN, or a DU, or portions thereof. Each receiving network access device may be configured to receive and measure pilot signals transmitted on the common set of resources, and also receive and measure pilot signals transmitted on dedicated sets of resources allocated to the UEs for which the network access device is a member of a monitoring set of network access devices for the UE. One or more of the receiving network access devices, or a CU to which receiving network access device(s) transmit the measurements of the pilot signals, may use the measurements to identify serving cells for the UEs, or to initiate a change of serving cell for one or more of the UEs.

*Example Collision Handling For CSI Reporting On PUSCH*

[0071] In certain systems, such as NR (new radio or 5G technology access) systems, semi-persistent channel state information (SP-CSI) is configured to be fed back on the physical uplink shared channel (PUSCH) by a user equipment (UE). A base station (BS) sends downlink control information (DCI) to the UE to trigger SP-CSI transmission, along with the PUSCH resource for the SP-CSI. Aperiodic CSI can also be transmitted (e.g., scheduled or configured) in the PUSCH. Scheduling request(s) (SRs), buffer status report(s) (BSRs), and/or hybrid automatic repeat request (HARQ) feedback (e.g., such as acknowledgements and/or negative acknowledgments) can be transmitted (e.g., scheduled or configured) in the physical uplink control channel (PUCCH). Thus, SP-CSI, A-CSI, uplink data, SR, BSR, and/or HARQ feedback can collide within the same transmission time interval (e.g., slot). PUSCH and PUCCH may not both be transmitted in the same TTI.

[0072] Accordingly, aspects of the present disclosure provide collision handling for CSI on the PUSCH and other uplink transmissions scheduled in the same slot.

[0073] FIG. 7 is a flow diagram illustrating example operations 700 for wireless communications, in accordance with certain aspects of the present disclosure. The operations 700 may be performed by a UE (e.g., such as a UE 120) for collision handling of CSI in PUSCH.

[0074] The operations 700 may begin, at 702, by receiving scheduling (or configuring) for at least one CSI transmission and at least one uplink transmission in a same slot. The at least one CSI transmission may be a SP-CSI and/or an A-CSI. The CSI transmission may be for a PUSCH in a slot (e.g., one or more symbols within the slot). The CSI transmission may be triggered by a downlink control information (DCI) from a BS (e.g., such as a BS 110). The uplink transmission may be uplink data the UE is scheduled to transmit in the PUSCH and/or a SR, a BSR, and/or a HARQ feedback (e.g., such as an ACK/NACK ) scheduled in the PUCCH in the same slot.

[0075] At 704, the UE determines to multiplex (e.g., time- and frequency-domain multiplex) the at least one CSI and the at least one uplink transmission in the slot or to drop the at least one CSI or the at least one uplink transmission in the slot.

[0076] At 706, the UE transmits in the slot at least one of: the at least one CSI transmission or the at least one uplink transmission based on the determination.

[0077] The CSI transmission may collide with SR (or BSR). In some examples, the CSI transmission may be considered to collide with SR only when the SR is a positive SR. In some examples, the CSI transmission be considered to collide with SR whether the SR is positive or negative (e.g., not due for transmission). According to certain aspects, when making the determination at 704, the UE may disregard the SR for the determination if the SR is a negative SR. Alternatively, when making the determination at 704, the UE considers the SR as colliding regardless whether the SR is positive or negative.

[0078] According to certain aspects, the UE determines (e.g., at 704) to multiplex the at least one CSI transmission and the SR, BSR, and/or HARQ feedback in the PUSCH. An encoding rule may be used for the multiplexed transmission. For example, the UE may encode bits for the PUSCH according to a priority associated with the at least one CSI transmission, the SR, and the HARQ feedback. The transmitting at 706 may include transmitted the encoded bits. According to certain aspects, the HARQ-ACK may have a higher priority in bit allocation than SR, followed by A/SP-CSI. For example, CSI transmission (SP-CSI and/or A-CSI) is associated with a first priority, SR is associated with a second priority higher than the first priority, and HARQ feedback is associated with a third priority higher than the second priority. In some examples, the HARQ feedback and SR have a same priority and are jointly encoded and multiplexed

with the at least one CSI transmission. In some examples, if the number of bits of the jointly encoded SR and HARQ feedback is equal to or less than 2 bits, then the jointly encoded SR and HARQ feedback punctures the CSI/PUSCH transmission. If the number of bits of the jointly encoded SR and HARQ feedback is greater than 2 bits, then the jointly encoded SR and HARQ feedback rate-matches the CSI/PUSCH.

**[0079]** According to certain aspects, the UE encodes bits for the transmission according to a rule, such a rule used for uplink control information (UCI) on PUSCH. For example, the equation described in 38.212 v.15.0.0 Section 6.3.1.1.3 of the 3GPP standards for determining the resource allocation for ACK multiplexing on PUSCH can be used to determine the resource allocation for the multiplexed HARQ feedback and SR. The equations described in 38.213 v.15.0.0 Section 9 of the 3GG standards for determining the number of ACK resources when ACK is multiplexed on PUSCH can be used to determine number of ACK+SR resources when ACK+SR is multiplexed on the PUSCH.

**[0080]** According to certain aspects, the UE determines (e.g., at 704) to multiplex the at least one CSI transmission and the SR, BSR, and/or HARQ transmission in the PUCCH. In some examples, the multiplexed CSI with SR, BSR, and/or HARQ is transmitted on the PUCCH resource allocated for the SR.

**[0081]** According to certain aspects, the UE determines (e.g., at 704) to drop the at least one CSI transmission in the slot. In some examples, the CSI transmission is dropped and the SR (or BSR) and/or HARQ feedback are reported on the PUCCH. In some examples, the CSI transmission is dropped and the SR and/or HARQ feedback are reported on the PUSCH.

**[0082]** According to certain aspects, the UE determines (e.g., at 704) to drop the SR (or BSR) transmission in the slot. In some examples, the CSI transmission and, if present, the HARQ feedback are reported on the PUSCH.

**[0083]** According to certain aspects, the UE determines (e.g., at 704) to drop the CSI transmission or the SR (or BSR) transmission based on an associated priority of the transmissions. In some examples, the priority is pre-determined or pre-configured a BS. The priority may be configured by a higher layer configuration or may be semi-statically configured (e.g., via radio resource control (RRC) signaling). In some

examples, SR is associated with a higher priority than CSI. In some examples, CSI is configured with a higher priority than SR. According to certain aspects, the UE is configured for multiple SR (or BSR). Each SR can be associated with its own quality-of-service (QoS) level. In some examples, the QoS level associated with the SRs is indicated implicitly by the index of the SR resource. In some examples, the QoS level associated with the SRs is explicitly indicated. In some examples, the priority associated with the SRs depends on the QoS level associated with the SR. For example, an SR associated with a high QoS level may have higher priority than the CSI and an SR associated with a lower QoS level may have a lower priority than the CSI.

[0084] According to certain aspects, the CSI transmission, such SP-CSI, collides with uplink data in the PUSCH. The UE determines (e.g., at 704) to drop the CSI transmission or the uplink data in the slot.

[0085] FIG. 8 is an example collision of SP-CSI and uplink data in a slot, in accordance with certain aspects of the present disclosure. According to certain aspects, the UE determines to drop the SP-CSI 804 if the uplink data 806 and SP-CSI 804 are scheduled in the same uplink slot 802 and the uplink data 806 is transmitted (e.g., the UE has uplink data to transmit). For example, the UE determines (e.g., at 704) to drop the at least one CSI transmission if the CSI transmission is scheduled to be transmitted in the same slot as data and the UE has data to send and to transmit the at least one CSI transmission if the CSI transmission is scheduled to be transmitted in the same slot as data and the UE does not have data to send in the slot.

[0086] FIG. 9 is an example collision of SP-CSI and uplink data in overlapping symbols in a slot, in accordance with certain aspects of the present disclosure. According to certain aspects, the UE determines to drop the SP-CSI 904 if the uplink data 906 and SP-CSI 904 are scheduled in overlapping symbols in the same uplink slot 902 and the uplink data 906 is transmitted (e.g., the UE has uplink data to transmit). For example, the UE determines (e.g., at 704) to drop the at least one CSI transmission if the CSI transmission and data are scheduled in a same symbol in the slot and to transmit the at least one CSI transmission if the CSI transmission and data are scheduled in a different symbol in the slot.

[0087] FIG. 10 is an example of SP-CSI transmitted before uplink data in a slot, in accordance with certain aspects of the present disclosure. According to certain aspects,

the UE determines to transmit (e.g., not to be dropped, allowed to be scheduled) the uplink data 1006 is dropped (or not scheduled) if the SP-CSI 1004 is transmitted before the preparation of the uplink data 1006 for transmission in the slot 1002. For example, the UE determines (e.g., at 704) to drop the at least one data transmission if the CSI transmission is scheduled to be transmitted before the data in the same slot.

[0088] FIG. 11 is a flow diagram illustrating example operations 1100 for wireless communications, in accordance with certain aspects of the present disclosure. The operations 1100 may be performed by a BS (e.g., such as a BS 110) for collision handling of CSI in PUSCH.

[0089] The operations 1100 begin, at 1102, by scheduling a UE to transmit SRs in a first set of slots and to transmit CSI in a second set of slots that is non-overlapping with the first set of slots.

[0090] At 1104, the BS receives SRs in the first set of slots and SP-CSI in the second set of slots.

[0091] According to certain aspects, the BS scheduled/configures the UE such that SRs and CSI do not collide. For example, the BS schedules (e.g., signals and/or configures) the UE (e.g., at 1102) to transmit SRs at a first slot offset  $n$  and a first periodicity  $P1$  and signals the UE (e.g., via a DCI) in a slot  $m$  to trigger CSI (e.g., SP-CSI) transmission at a second periodicity  $P2$ .

[0092] In some examples, the BS determines the slot  $m$  to trigger SP-CSI transmission and the second periodicity  $P2$  based on the first slot offset  $n$ , the first periodicity  $P1$ , and a feedback latency  $Y$  associated with the SP-CSI. Thus, for the integers  $j, k$  greater than or equal to zero, the BS does not schedule  $n + j * P1 = m + Y + k * P2$ , such that the first set of slots for the SR and the second set of slots for SP-CSI do not collide.

[0093] According to certain aspects, A-CSI is not allowed to be fed back on the same TTI (e.g., slot) with SR. For example, the BS configures the UE not to transmit, or does not schedule the UE for, A-CSI in a same slot as a SR.

[0094] Aspects of the present disclosure may reduce collisions between CSI and other uplink transmissions in the same slot. The reduced collisions may improve communications in a network, such as the wireless communication network 100. For

example, the reduced collisions may improve the communications between a UE 120 and a BS 110. The reduced collisions may result in improved reception by the BS 110 of the transmissions from the UE, for example, with less interference, improve SNR, and reduction of failed or missed transmissions from the UE. The improved reception at the BS 110 may result better functioning of the processing at the BS 110, for example, with improved efficiency and reduced power consumption. In turn, the functioning of the UE 120 may be improved.

[0095] **FIG. 12** illustrates a communications device 1200 that may include various components (e.g., corresponding to means-plus-function components) configured to perform operations for the techniques disclosed herein, such as the operations illustrated in **FIG. 7**. The communications device 1200 includes a processing system 1202 coupled to a transceiver 1208. The transceiver 1208 is configured to transmit and receive signals for the communications device 1200 via an antenna 1210, such as the various signals, including, for example, CSI, SR, HARQ feedback, and/or data as described herein. The processing system 1202 may be configured to perform processing functions for the communications device 1200, including processing signals received and/or to be transmitted by the communications device 1200.

[0096] The processing system 1202 includes a processor 1204 coupled to a computer-readable medium/memory 1212 via a bus 1206. In certain aspects, the computer-readable medium/memory 1212 is configured to store instructions (e.g., computer executable code) that when executed by the processor 1204, cause the processor 1204 to perform the operations illustrated in **FIG. 7**, or other operations for performing the various techniques discussed herein collision handling for CSI on PUSCH. In certain aspects, computer-readable medium/memory 1212 stores code for receiving scheduling 1214, code determining scheduled transmissions to multiplex or drop 1216, and code for transmitting based on the determination 1218.

[0097] **FIG. 13** illustrates a communications device 1300 that may include various components (e.g., corresponding to means-plus-function components) configured to perform operations for the techniques disclosed herein, such as the operations illustrated in **FIG. 11**. The communications device 1300 includes a processing system 1302 coupled to a transceiver 1308. The transceiver 1308 is configured to transmit and receive signals for the communications device 1300 via an antenna 1310, such as the

various signals, including, for example, CSI, SR, HARQ feedback, and/or data as described herein. The processing system 1302 may be configured to perform processing functions for the communications device 1300, including processing signals received and/or to be transmitted by the communications device 1300.

[0098] The processing system 1302 includes a processor 1304 coupled to a computer-readable medium/memory 1312 via a bus 1306. In certain aspects, the computer-readable medium/memory 1312 is configured to store instructions (e.g., computer executable code) that when executed by the processor 1304, cause the processor 1304 to perform the operations illustrated in **FIG. 11**, or other operations for performing the various techniques discussed herein collision handling for CSI on PUSCH. In certain aspects, computer-readable medium/memory 1312 stores code for scheduling SR and CSI in non-overlapping slots 1314 and code for receiving SR and CSI 1316.

[0099] The methods disclosed herein comprise one or more steps or actions for achieving the methods. The method steps and/or actions may be interchanged with one another without departing from the scope of the claims. In other words, unless a specific order of steps or actions is specified, the order and/or use of specific steps and/or actions may be modified without departing from the scope of the claims.

[0100] As used herein, a phrase referring to “at least one of” a list of items refers to any combination of those items, including single members. As an example, “at least one of: a, b, or c” is intended to cover a, b, c, a-b, a-c, b-c, and a-b-c, as well as any combination with multiples of the same element (e.g., a-a, a-a-a, a-a-b, a-a-c, a-b-b, a-c-c, b-b, b-b-b, b-b-c, c-c, and c-c-c or any other ordering of a, b, and c).

[0101] As used herein, the term “determining” encompasses a wide variety of actions. For example, “determining” may include calculating, computing, processing, deriving, investigating, looking up (e.g., looking up in a table, a database or another data structure), ascertaining and the like. Also, “determining” may include receiving (e.g., receiving information), accessing (e.g., accessing data in a memory) and the like. Also, “determining” may include resolving, selecting, choosing, establishing and the like.

**[0102]** The previous description is provided to enable any person skilled in the art to practice the various aspects described herein. Various modifications to these aspects will be readily apparent to those skilled in the art, and the generic principles defined herein may be applied to other aspects. Thus, the claims are not intended to be limited to the aspects shown herein, but is to be accorded the full scope consistent with the language of the claims, wherein reference to an element in the singular is not intended to mean “one and only one” unless specifically so stated, but rather “one or more.” Unless specifically stated otherwise, the term “some” refers to one or more. All structural and functional equivalents to the elements of the various aspects described throughout this disclosure that are known or later come to be known to those of ordinary skill in the art are expressly incorporated herein by reference and are intended to be encompassed by the claims. Moreover, nothing disclosed herein is intended to be dedicated to the public regardless of whether such disclosure is explicitly recited in the claims. No claim element is to be construed under the provisions of 35 U.S.C. §112(f) unless the element is expressly recited using the phrase “means for” or, in the case of a method claim, the element is recited using the phrase “step for.”

**[0103]** The various operations of methods described above may be performed by any suitable means capable of performing the corresponding functions. The means may include various hardware and/or software component(s) and/or module(s), including, but not limited to a circuit, an application specific integrated circuit (ASIC), or processor. Generally, where there are operations illustrated in figures, those operations may have corresponding counterpart means-plus-function components with similar numbering.

**[0104]** The various illustrative logical blocks, modules and circuits described in connection with the present disclosure may be implemented or performed with a general purpose processor, a digital signal processor (DSP), an application specific integrated circuit (ASIC), a field programmable gate array (FPGA) or other programmable logic device (PLD), discrete gate or transistor logic, discrete hardware components, or any combination thereof designed to perform the functions described herein. A general-purpose processor may be a microprocessor, but in the alternative, the processor may be any commercially available processor, controller, microcontroller, or state machine. A processor may also be implemented as a combination of computing devices, e.g., a

combination of a DSP and a microprocessor, a plurality of microprocessors, one or more microprocessors in conjunction with a DSP core, or any other such configuration.

**[0105]** If implemented in hardware, an example hardware configuration may comprise a processing system in a wireless node. The processing system may be implemented with a bus architecture. The bus may include any number of interconnecting buses and bridges depending on the specific application of the processing system and the overall design constraints. The bus may link together various circuits including a processor, machine-readable media, and a bus interface. The bus interface may be used to connect a network adapter, among other things, to the processing system via the bus. The network adapter may be used to implement the signal processing functions of the PHY layer. In the case of a user terminal 120 (see **FIG. 1**), a user interface (e.g., keypad, display, mouse, joystick, etc.) may also be connected to the bus. The bus may also link various other circuits such as timing sources, peripherals, voltage regulators, power management circuits, and the like, which are well known in the art, and therefore, will not be described any further. The processor may be implemented with one or more general-purpose and/or special-purpose processors. Examples include microprocessors, microcontrollers, DSP processors, and other circuitry that can execute software. Those skilled in the art will recognize how best to implement the described functionality for the processing system depending on the particular application and the overall design constraints imposed on the overall system.

**[0106]** If implemented in software, the functions may be stored or transmitted over as one or more instructions or code on a computer readable medium. Software shall be construed broadly to mean instructions, data, or any combination thereof, whether referred to as software, firmware, middleware, microcode, hardware description language, or otherwise. Computer-readable media include both computer storage media and communication media including any medium that facilitates transfer of a computer program from one place to another. The processor may be responsible for managing the bus and general processing, including the execution of software modules stored on the machine-readable storage media. A computer-readable storage medium may be coupled to a processor such that the processor can read information from, and write information to, the storage medium. In the alternative, the storage medium may be integral to the

processor. By way of example, the machine-readable media may include a transmission line, a carrier wave modulated by data, and/or a computer readable storage medium with instructions stored thereon separate from the wireless node, all of which may be accessed by the processor through the bus interface. Alternatively, or in addition, the machine-readable media, or any portion thereof, may be integrated into the processor, such as the case may be with cache and/or general register files. Examples of machine-readable storage media may include, by way of example, RAM (Random Access Memory), flash memory, ROM (Read Only Memory), PROM (Programmable Read-Only Memory), EPROM (Erasable Programmable Read-Only Memory), EEPROM (Electrically Erasable Programmable Read-Only Memory), registers, magnetic disks, optical disks, hard drives, or any other suitable storage medium, or any combination thereof. The machine-readable media may be embodied in a computer-program product.

**[0107]** A software module may comprise a single instruction, or many instructions, and may be distributed over several different code segments, among different programs, and across multiple storage media. The computer-readable media may comprise a number of software modules. The software modules include instructions that, when executed by an apparatus such as a processor, cause the processing system to perform various functions. The software modules may include a transmission module and a receiving module. Each software module may reside in a single storage device or be distributed across multiple storage devices. By way of example, a software module may be loaded into RAM from a hard drive when a triggering event occurs. During execution of the software module, the processor may load some of the instructions into cache to increase access speed. One or more cache lines may then be loaded into a general register file for execution by the processor. When referring to the functionality of a software module below, it will be understood that such functionality is implemented by the processor when executing instructions from that software module.

**[0108]** Also, any connection is properly termed a computer-readable medium. For example, if the software is transmitted from a website, server, or other remote source using a coaxial cable, fiber optic cable, twisted pair, digital subscriber line (DSL), or wireless technologies such as infrared (IR), radio, and microwave, then the coaxial cable, fiber optic cable, twisted pair, DSL, or wireless technologies such as infrared, radio, and microwave are included in the definition of medium. Disk and disc, as used herein,

include compact disc (CD), laser disc, optical disc, digital versatile disc (DVD), floppy disk, and Blu-ray® disc where disks usually reproduce data magnetically, while discs reproduce data optically with lasers. Thus, in some aspects computer-readable media may comprise non-transitory computer-readable media (e.g., tangible media). In addition, for other aspects computer-readable media may comprise transitory computer-readable media (e.g., a signal). Combinations of the above should also be included within the scope of computer-readable media.

**[0109]** Thus, certain aspects may comprise a computer program product for performing the operations presented herein. For example, such a computer program product may comprise a computer-readable medium having instructions stored (and/or encoded) thereon, the instructions being executable by one or more processors to perform the operations described herein. For example, instructions for performing the operations described herein and illustrated in **FIG. 7 and FIG. 11**.

**[0110]** Further, it should be appreciated that modules and/or other appropriate means for performing the methods and techniques described herein can be downloaded and/or otherwise obtained by a user terminal and/or base station as applicable. For example, such a device can be coupled to a server to facilitate the transfer of means for performing the methods described herein. Alternatively, various methods described herein can be provided via storage means (e.g., RAM, ROM, a physical storage medium such as a compact disc (CD) or floppy disk, etc.), such that a user terminal and/or base station can obtain the various methods upon coupling or providing the storage means to the device. Moreover, any other suitable technique for providing the methods and techniques described herein to a device can be utilized.

**[0111]** It is to be understood that the claims are not limited to the precise configuration and components illustrated above. Various modifications, changes and variations may be made in the arrangement, operation and details of the methods and apparatus described above without departing from the scope of the claims.

**WHAT IS CLAIMED IS:**

1. A method for wireless communications by a user equipment (UE), comprising:  
receiving scheduling for at least one channel state information (CSI) transmission and at least one uplink transmission in a same slot; and  
determining to multiplex the at least one CSI and the at least one uplink transmission in the slot or to drop the at least one CSI or the at least one uplink transmission in the slot; and  
transmitting in the slot at least one of: the at least one CSI transmission or the at least one uplink transmission based on the determination.
2. The method of claim 1, wherein the multiplexing comprises time-domain and frequency-domain multiplexing.
3. The method of claim 1, wherein:  
the at least one CSI transmission comprises at least one of: a semi-persistent CSI (SP-CSI) or an aperiodic CSI (A-CSI) transmission; and  
the at least one uplink transmission comprises at least one of: a scheduling request (SR), a hybrid automatic repeat request (HARQ) feedback, or a data transmission.
4. The method of claim 3, wherein the scheduling request comprises a buffer status report (BSR).
5. The method of claim 3, wherein at least one of:  
the SP-CSI, A-CSI, or the data transmission is scheduled for transmission in a physical uplink shared channel (PUSCH) by a downlink control information (DCI); and  
the SR or HARQ feedback is scheduled for transmission in a physical uplink control channel (PUCCH).
6. The method of claim 3, wherein determining to multiplex the at least one CSI and the at least one uplink transmission in the slot or to drop the at least one CSI or the at least one uplink transmission in the slot comprises disregarding the SR for the

determination if the SR is a negative SR.

7. The method of claim 3, wherein the determination comprises:  
determining to multiplex the at least one CSI transmission and at least one of:  
the SR or HARQ feedback in a physical uplink shared channel (PUSCH).
8. The method of claim 7, further comprising:  
encoding bits for the PUSCH according to a priority associated with the at least  
one CSI transmission, the SR, and the HARQ feedback.
9. The method of claim 8, wherein the at least one CSI transmission is associated  
with a first priority, the SR is associated with a second priority higher than the first  
priority, and the HARQ feedback is associated with a third priority higher than the  
second priority.
10. The method of claim 7, further comprising:  
jointly encoding the SR and HARQ feedback, wherein the jointly encoded SR  
and HARQ feedback are multiplexed with the at least one CSI transmission.
11. The method of claim 10, further comprising:  
puncturing the at least one CSI transmission on the PUSCH if a number of bits  
of the jointly encoded SR and HARQ feedback is equal to or less than 2 bits; and  
rate-matching the jointly encoded SR and HARQ feedback with the at least one  
CSI on the PUSCH if the number of bits of the jointly encoded SR and HARQ feedback  
is greater than 2 bits.
12. The method of claim 3, wherein the determination comprises:  
determining to multiplex the at least one CSI transmission and at least one of:  
the SR or HARQ feedback in a physical uplink control channel (PUCCH).
13. The method of claim 12, wherein the multiplexing is on PUCCH resources  
allocated for the SR.

14. The method of claim 1, wherein the determination comprises:  
determining to drop the at least one CSI transmission.
15. The method of claim 14, wherein the transmitting comprising:  
transmitting the at least one uplink transmission in a physical uplink shared channel (PUSCH).
16. The method of claim 14, wherein the transmitting comprising:  
transmitting the at least one uplink transmission in a physical uplink control channel (PUCCH).
17. The method of claim 3, wherein the determination comprises:  
determining to drop the SR.
18. The method of claim 17, wherein the transmitting comprises:  
transmitting the at least one CSI transmission in a physical uplink shared channel (PUSCH); and  
if present, transmitting the HARQ feedback in the PUSCH.
19. The method of claim 1, wherein the determination comprises:  
determining to drop the at least one CSI transmission or the at least one uplink transmission based on an associated priority.
20. The method of claim 19, wherein the associated priority is configured by a base station (BS).
21. The method of claim 20, wherein multiple SRs are associated with multiple priorities based on a quality-of-service (QoS) level of the SRs.
22. The method of claim 1, wherein the determination comprises:  
determining to drop the at least one CSI transmission if the CSI transmission is scheduled to be transmitted in the same slot as data and the UE has data to send; and  
determining to transmit the at least one CSI transmission if the CSI transmission

is scheduled to be transmitted in the same slot as data and the UE does not have data to send in the slot.

23. The method of claim 1, wherein the determination comprises:  
determining to drop the at least one CSI transmission if the CSI transmission and data are scheduled in a same symbol in the slot; and  
determining to transmit the at least one CSI transmission if the CSI transmission and data are scheduled in a different symbol in the slot.
24. The method of claim 1, wherein the determination comprises:  
determining to drop the at least one data transmission if the CSI transmission is scheduled to be transmitted before the data in the same slot.
25. A method for wireless communications by a base station (BS), comprising:  
scheduling a user equipment (UE) to transmit scheduling requests (SRs) in a first set of slots and to transmit channel state information (CSI) in a second set of slots that is non-overlapping with the first set of slots; and  
receiving SRs in the first set of slots and CSI in the second set of slots.
26. The method of claim 25, wherein scheduling the UE to transmit the SRs in the first set of slots comprises configuring the UE to transmit SRs at a first slot offset and a first periodicity.
27. The method of claim 26, wherein scheduling the UE to transmit the SP-CSI in the second set of slots comprises:  
signaling the UE in a slot to trigger semi-persistent CSI (SP-CSI) transmission at a second periodicity.
28. The method of claim 27, further comprising:  
determining the slot to trigger SP-CSI transmission and the second periodicity based on the first slot offset, the first periodicity, and a feedback latency associated with the SP-CSI.

29. The method of claim 25, further comprising:  
configuring the UE not to transmit aperiodic CSI (A-CSI) in a same slot as a SR.
30. An apparatus for wireless communications, comprising:  
means for receiving scheduling for at least one channel state information (CSI) transmission and at least one uplink transmission in a same slot; and  
means for determining to multiplex the at least one CSI and the at least one uplink transmission in the slot or to drop the at least one CSI or the at least one uplink transmission in the slot; and  
means for transmitting in the slot at least one of: the at least one CSI transmission or the at least one uplink transmission based on the determination.
31. An apparatus for wireless communications, comprising:  
means for scheduling a user equipment (UE) to transmit scheduling requests (SRs) in a first set of slots and to transmit channel state information (CSI) in a second set of slots that is non-overlapping with the first set of slots; and  
means for receiving SRs in the first set of slots and CSI in the second set of slots.
32. An apparatus for wireless communications, comprising:  
a receiver configured to receive scheduling for at least one channel state information (CSI) transmission and at least one uplink transmission in a same slot; and  
at least one processor coupled with a memory and configured to determine to multiplex the at least one CSI and the at least one uplink transmission in the slot or to drop the at least one CSI or the at least one uplink transmission in the slot; and  
a transmitter configured to transmit in the slot at least one of: the at least one CSI transmission or the at least one uplink transmission based on the determination.
33. An apparatus for wireless communications, comprising:  
at least one processor coupled with a memory and configured to schedule a user equipment (UE) to transmit scheduling requests (SRs) in a first set of slots and to transmit channel state information (CSI) in a second set of slots that is non-overlapping with the first set of slots; and  
a receiver configured to receive SRs in the first set of slots and CSI in the second

set of slots.

34. A computer readable medium having computer executable code stored there for wireless communications by a user equipment (UE), comprising:

code for receiving scheduling for at least one channel state information (CSI) transmission and at least one uplink transmission in a same slot; and

code for determining to multiplex the at least one CSI and the at least one uplink transmission in the slot or to drop the at least one CSI or the at least one uplink transmission in the slot; and

code for transmitting in the slot at least one of: the at least one CSI transmission or the at least one uplink transmission based on the determination.

35. A computer readable medium having computer executable code stored there for wireless communications by a base station (BS), comprising:

code for scheduling a user equipment (UE) to transmit scheduling requests (SRs) in a first set of slots and to transmit channel state information (CSI) in a second set of slots that is non-overlapping with the first set of slots; and

code for receiving SRs in the first set of slots and CSI in the second set of slots.

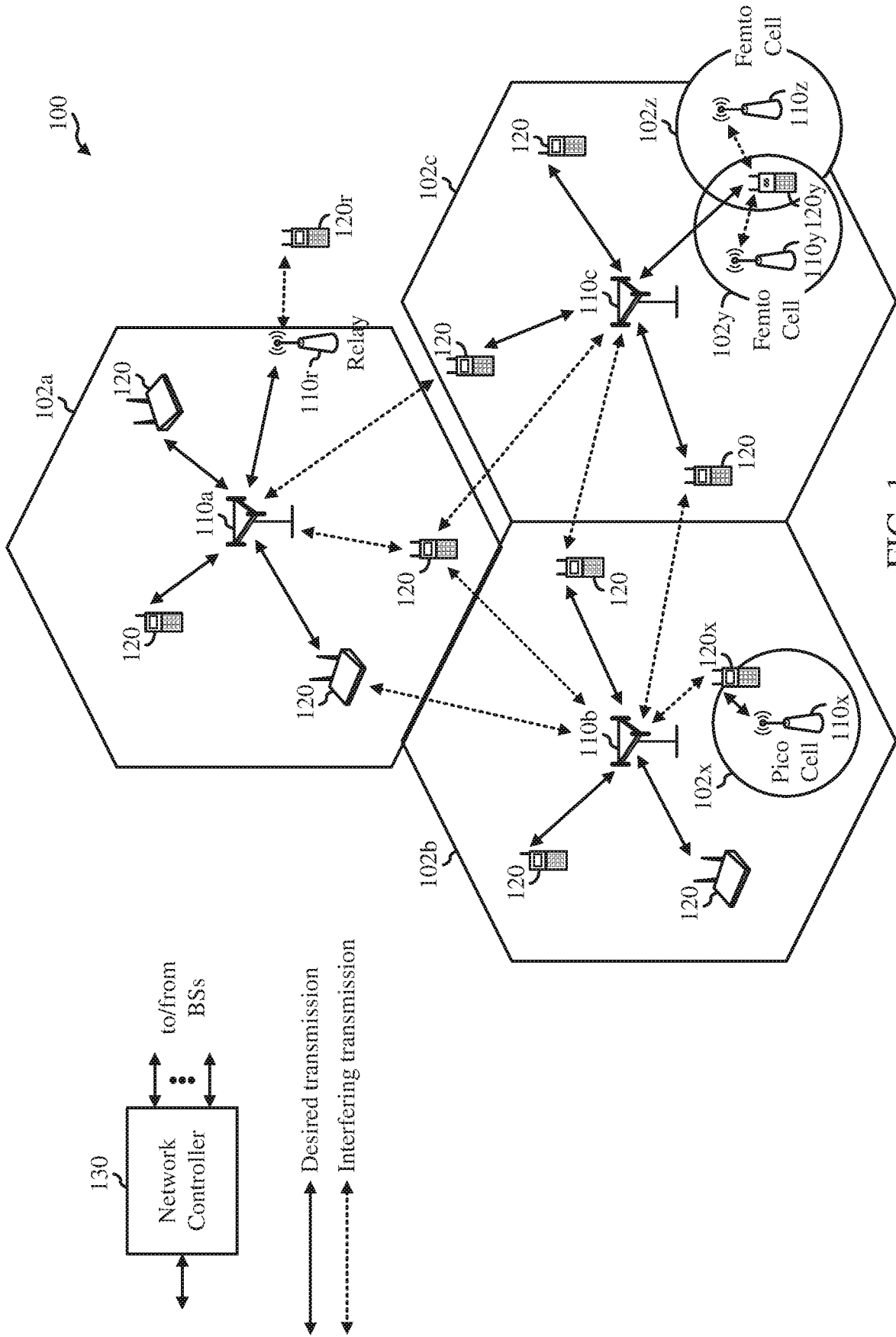

FIG. 1

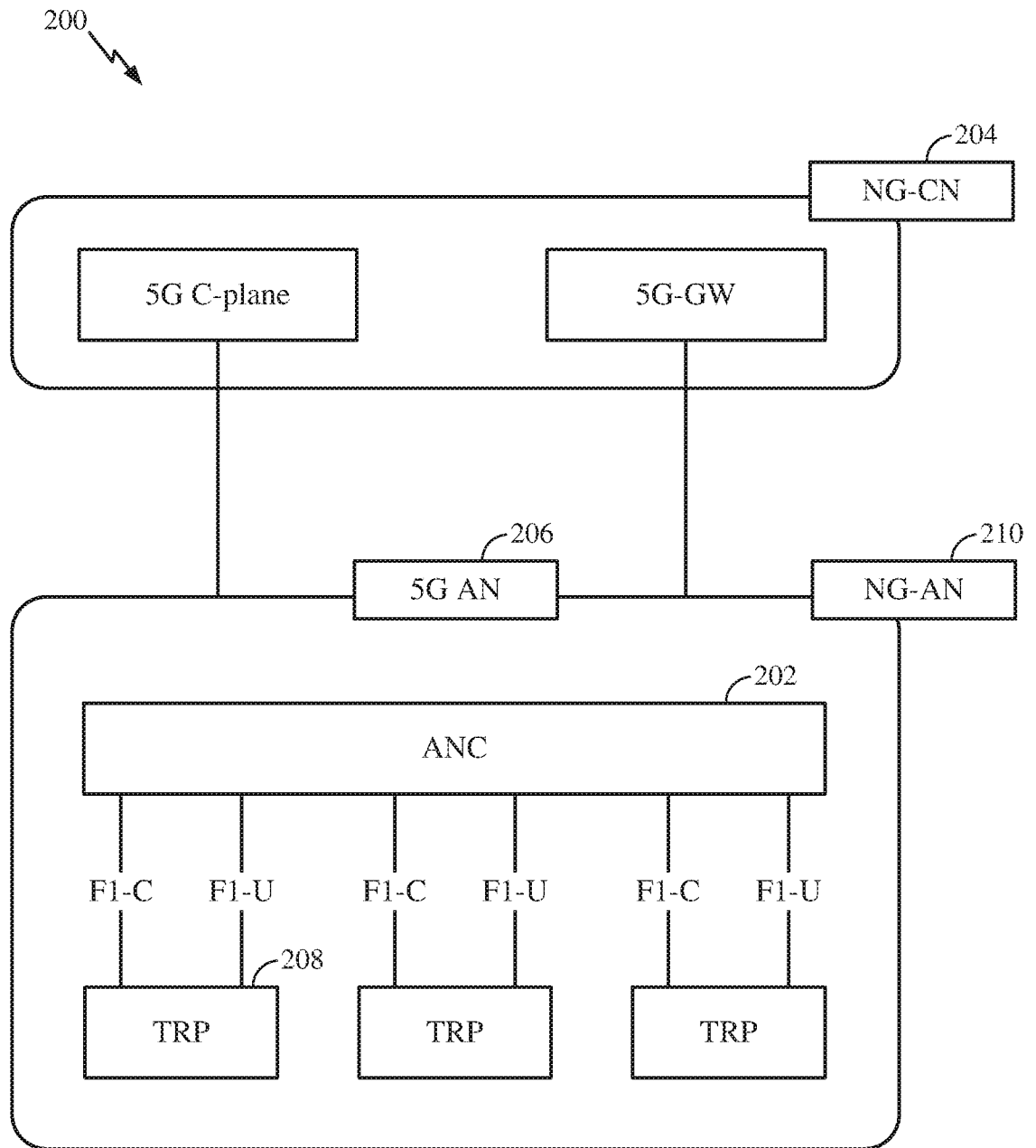

FIG. 2

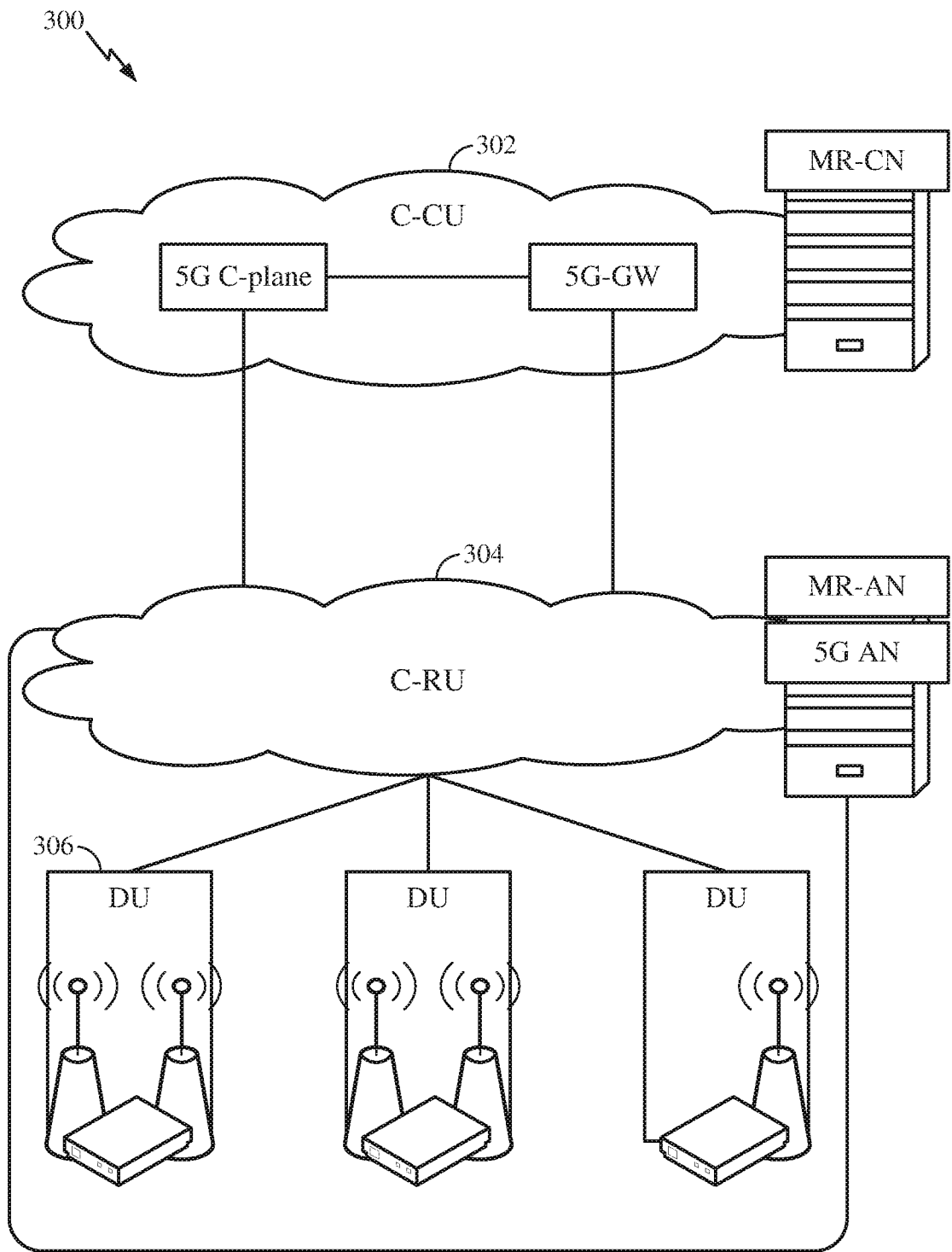

FIG. 3

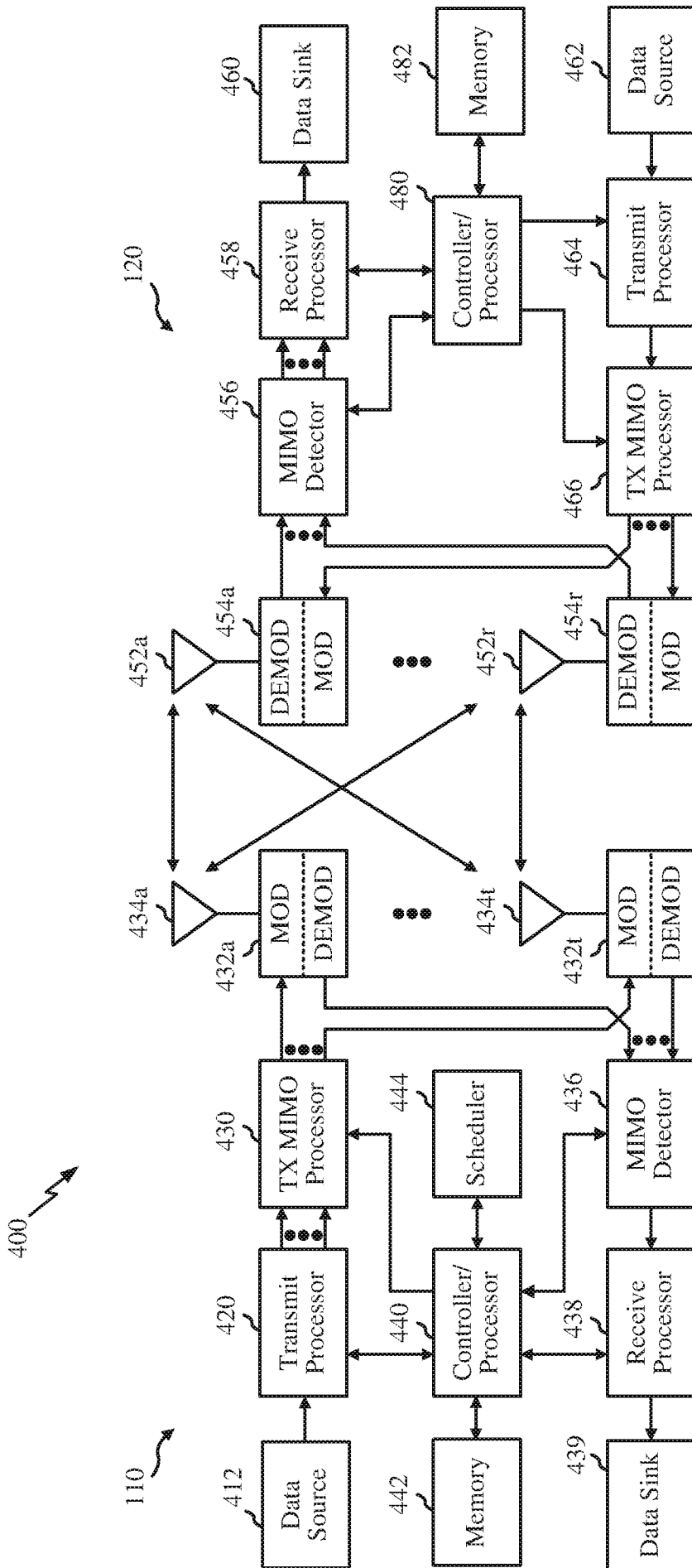

FIG. 4

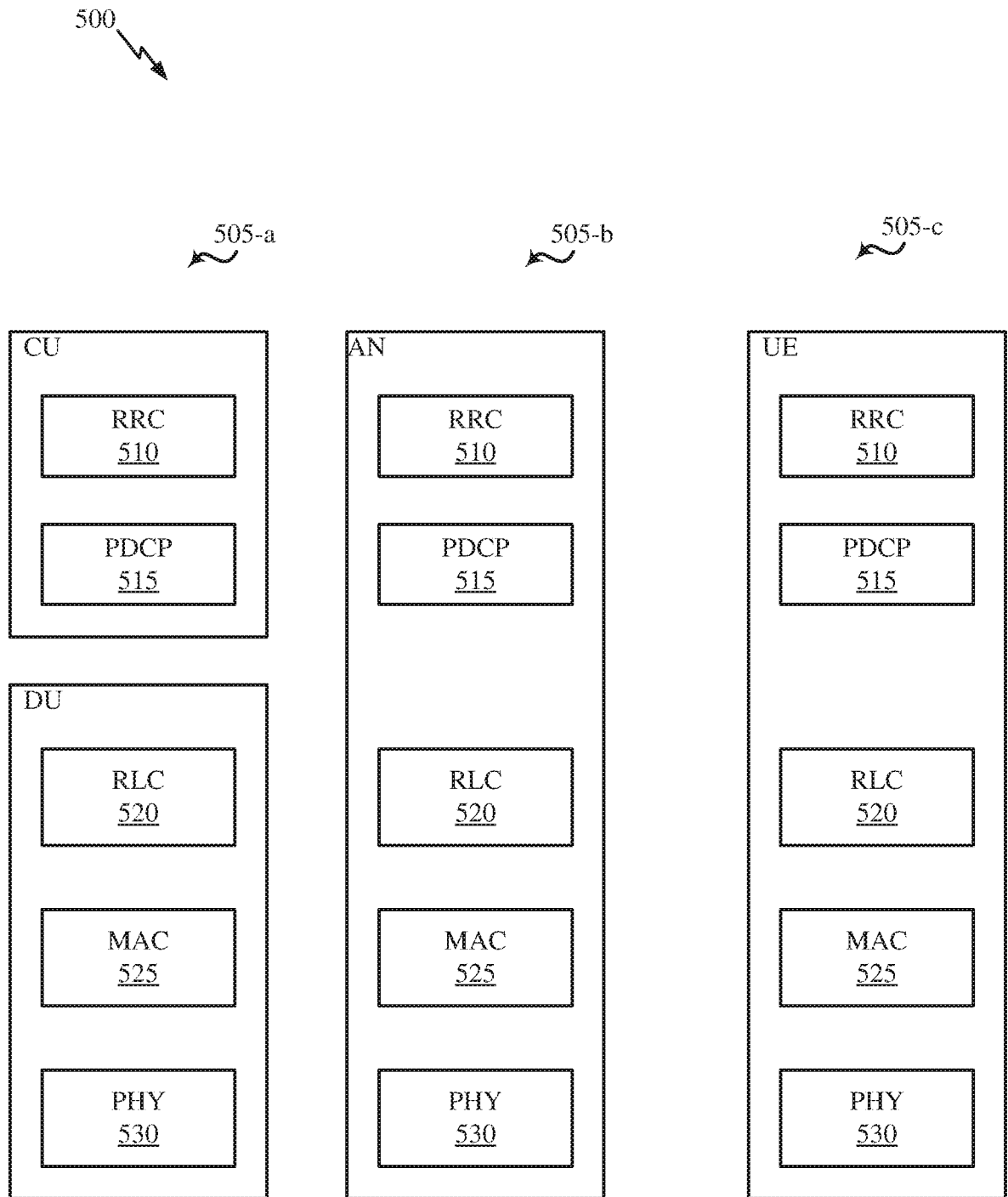

FIG. 5

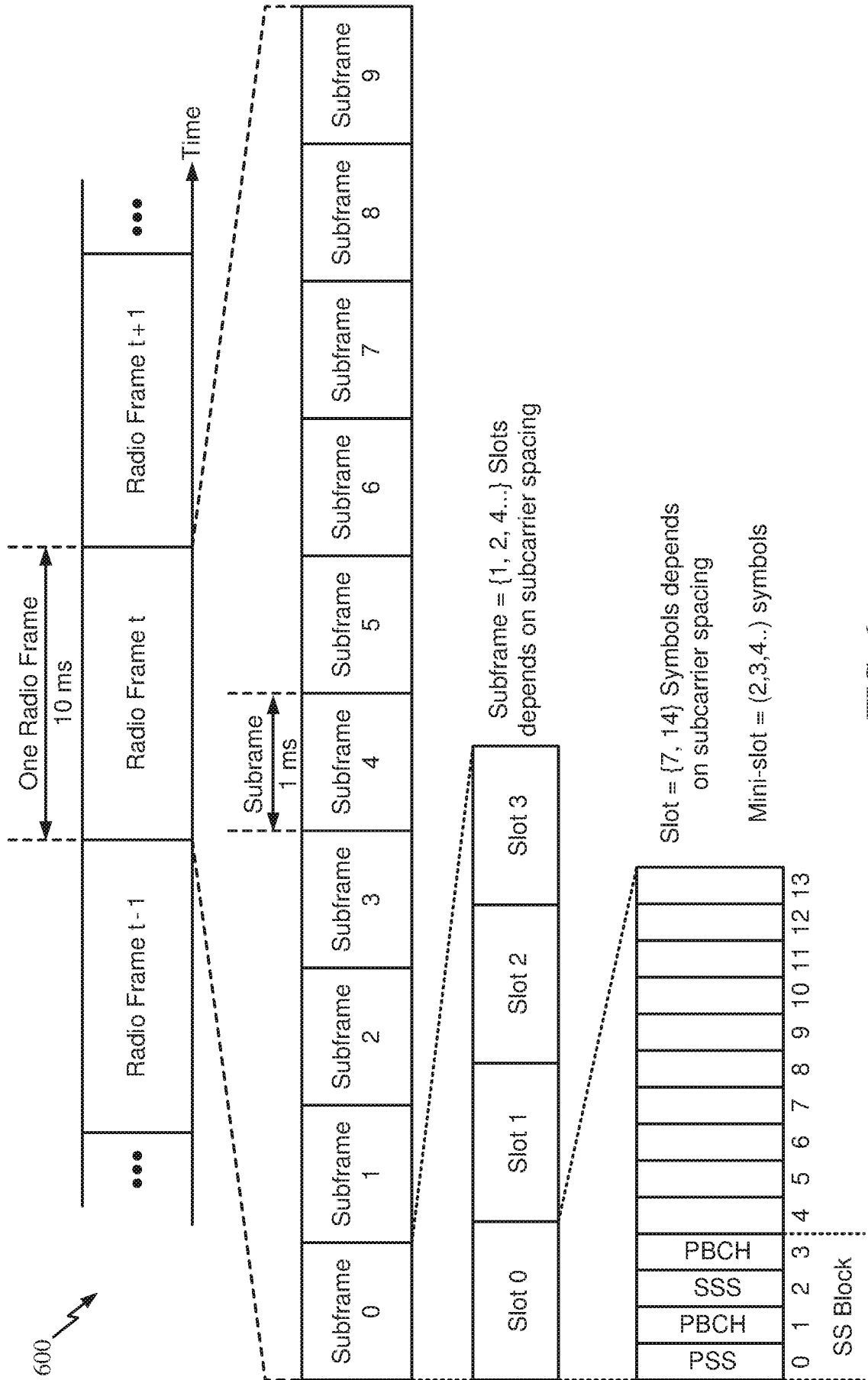

FIG. 6

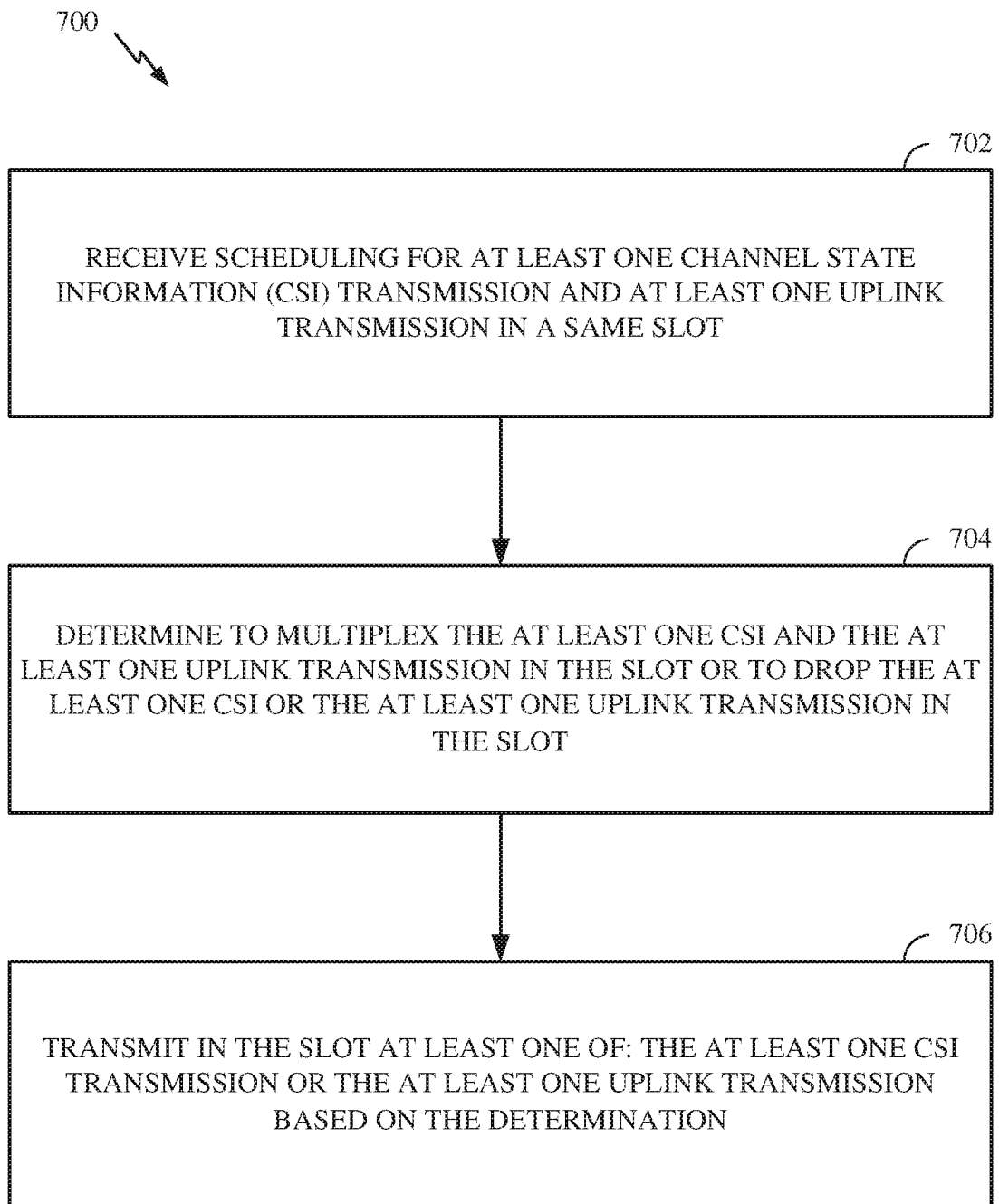

FIG. 7

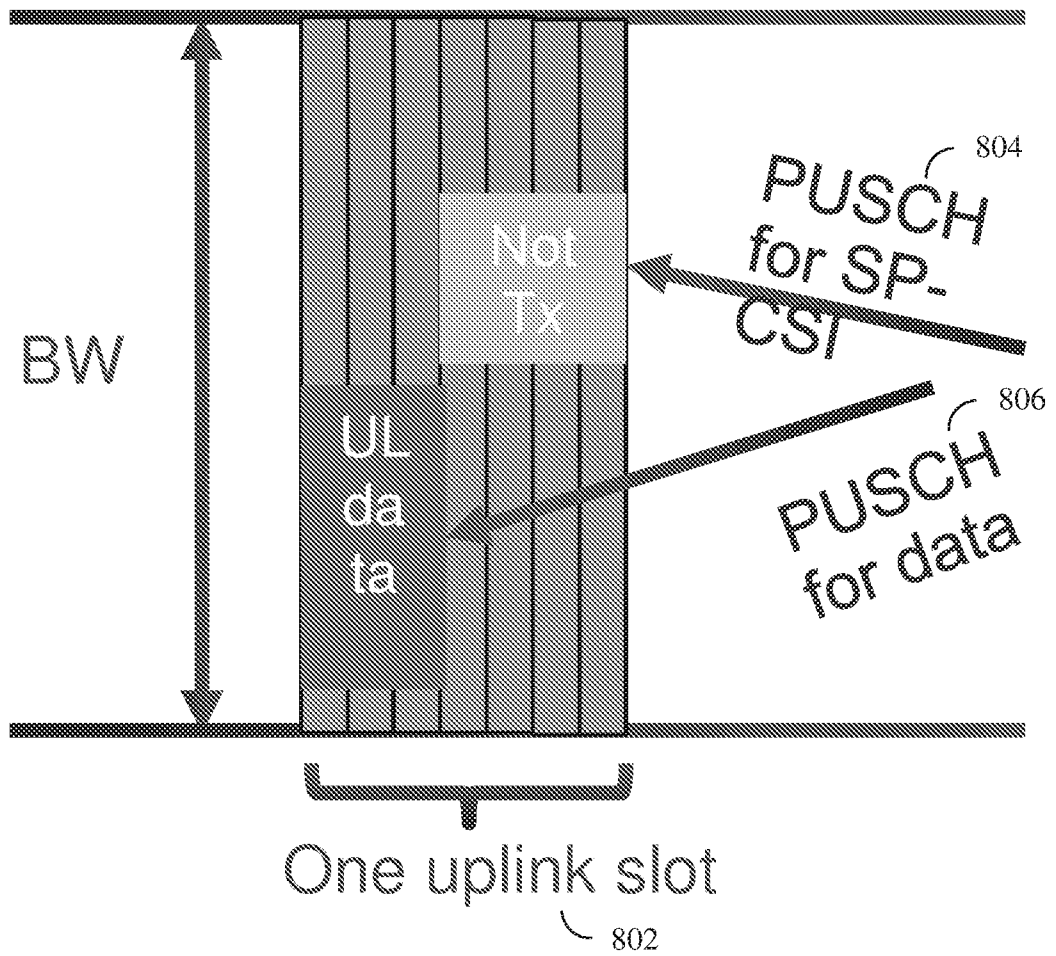

FIG. 8

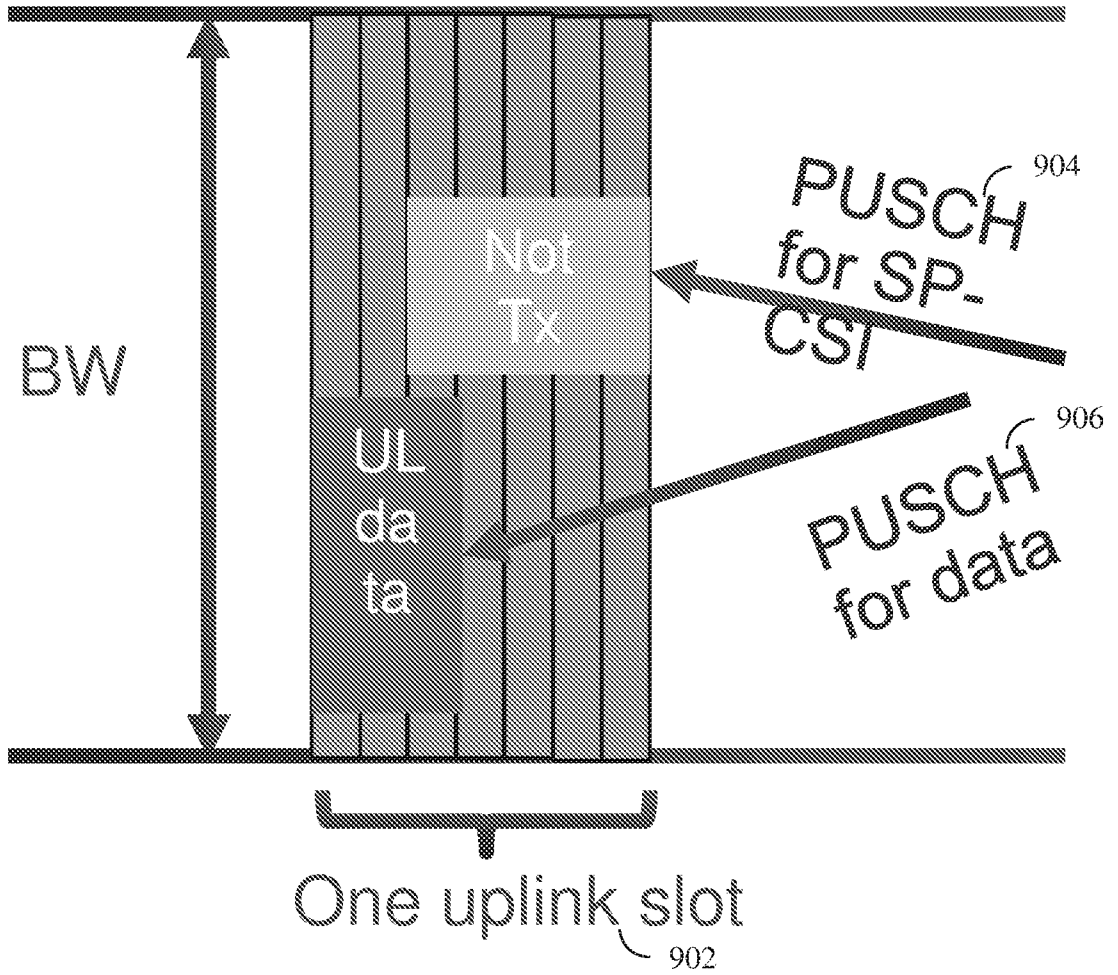

FIG. 9

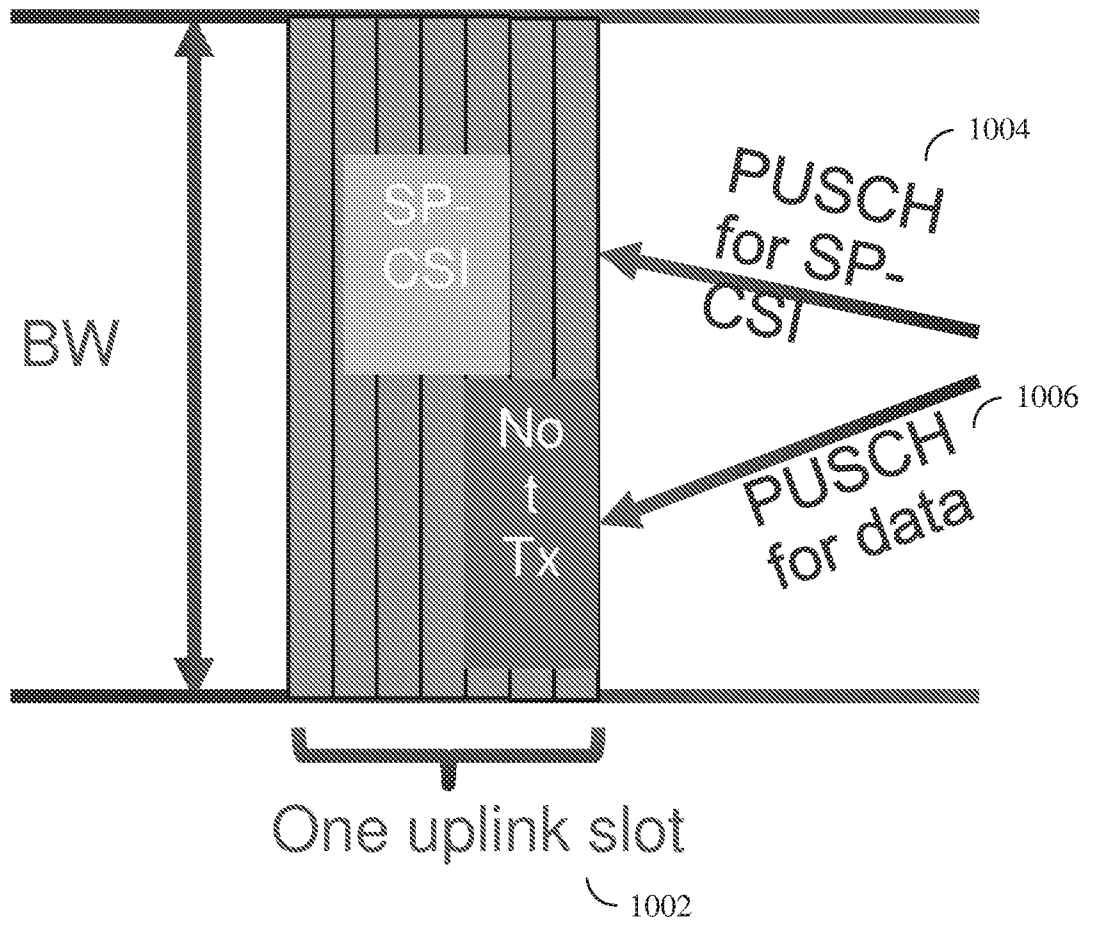

FIG. 10

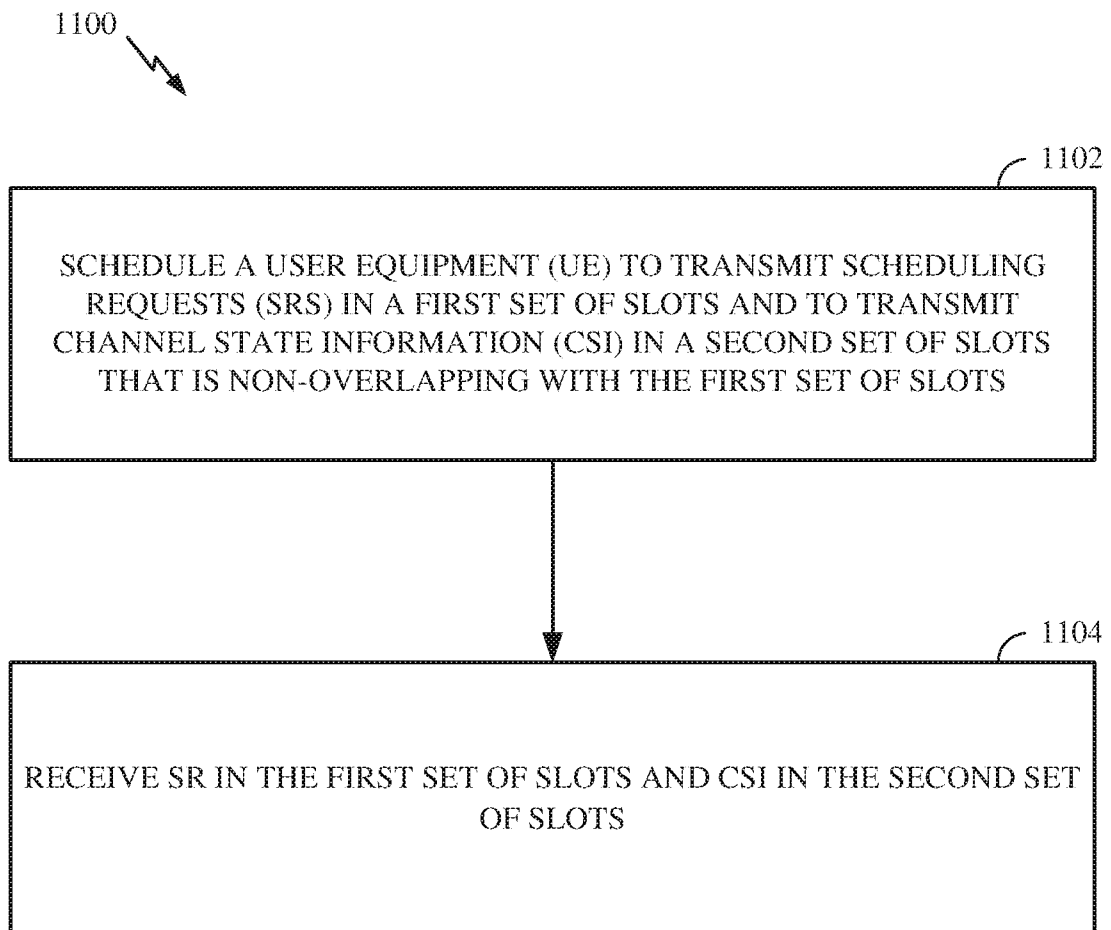

FIG. 11

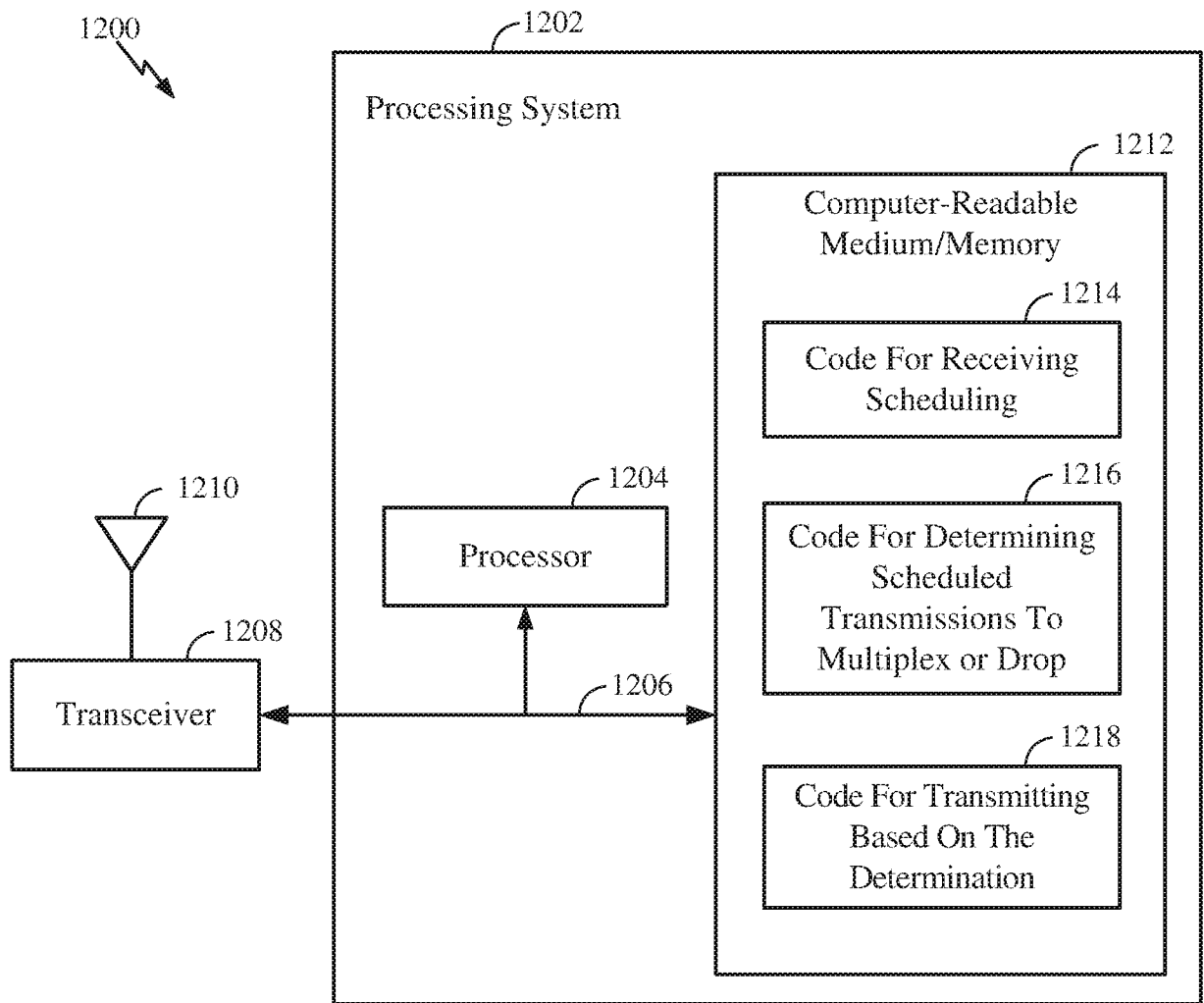

FIG. 12

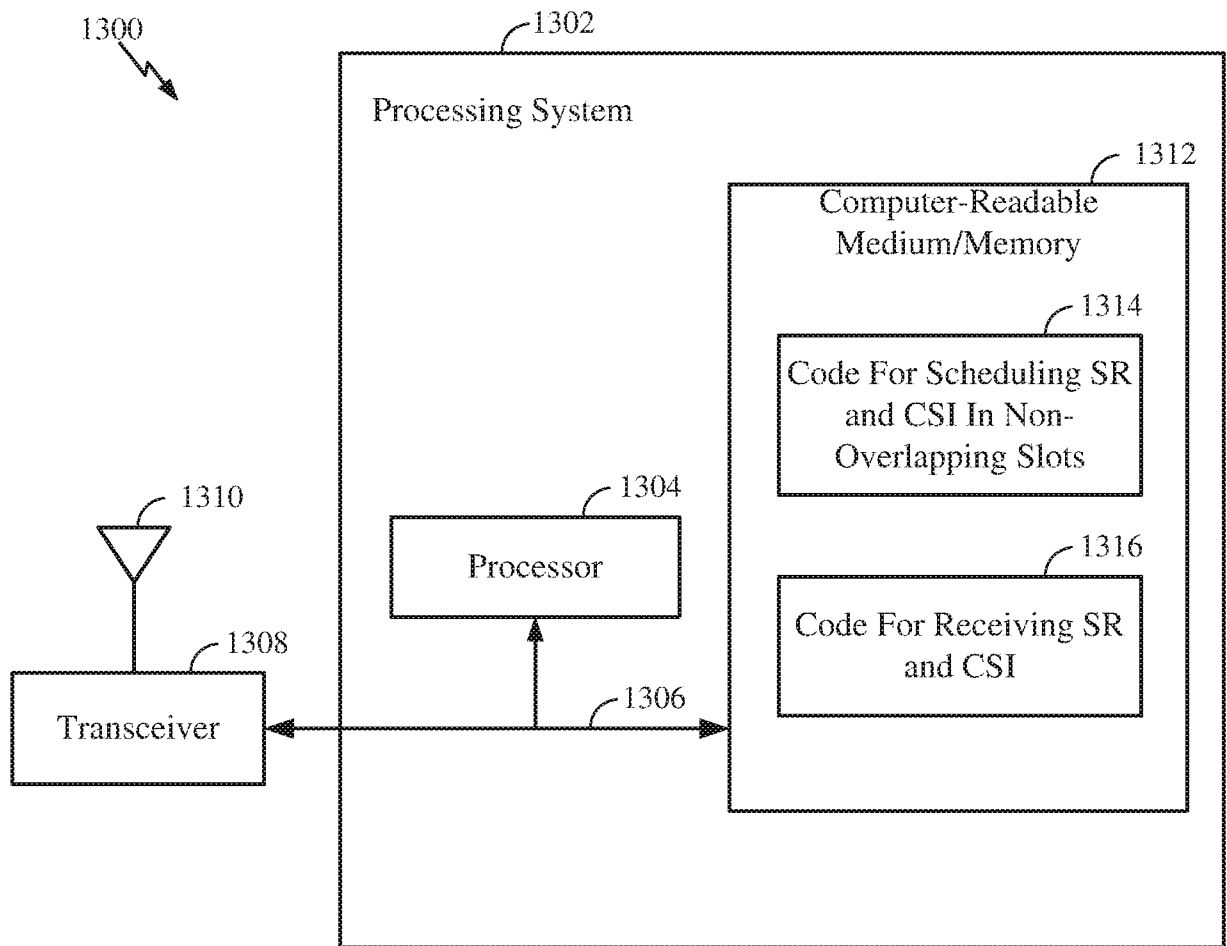

FIG. 13

## INTERNATIONAL SEARCH REPORT

International application No.

**PCT/CN2018/082064****A. CLASSIFICATION OF SUBJECT MATTER**

H04L 1/18(2006.01)i

According to International Patent Classification (IPC) or to both national classification and IPC

**B. FIELDS SEARCHED**

Minimum documentation searched (classification system followed by classification symbols)

H04L

Documentation searched other than minimum documentation to the extent that such documents are included in the fields searched

Electronic data base consulted during the international search (name of data base and, where practicable, search terms used)

EPODOC; WPI; CNPAT; CNKI: ACK, TTI, CSI, HARQ, SR, priority, overlap, multiplex, transmit+, slot, collision.

**C. DOCUMENTS CONSIDERED TO BE RELEVANT**

Category*	Citation of document, with indication, where appropriate, of the relevant passages	Relevant to claim No.
X	CN 104429015 A (INTEL CORPORATION) 18 March 2015 (2015-03-18) description paragraphs [0036]-[0041], [0046], [0111], [0165]-[0167]	1-35
A	EP 2385647 A2 (HTC CORPORATION) 09 November 2011 (2011-11-09) the whole document	1-35
A	WO 2009100217 A2 (QUALCOMM INCORPORATED) 13 August 2009 (2009-08-13) the whole document	1-35
A	CN 101800620 A (ZTE CORPORATION) 11 August 2010 (2010-08-11) the whole document	1-35

 Further documents are listed in the continuation of Box C. See patent family annex.

\* Special categories of cited documents:

"A" document defining the general state of the art which is not considered to be of particular relevance

"E" earlier application or patent but published on or after the international filing date

"L" document which may throw doubts on priority claim(s) or which is cited to establish the publication date of another citation or other special reason (as specified)

"O" document referring to an oral disclosure, use, exhibition or other means

"P" document published prior to the international filing date but later than the priority date claimed

"T" later document published after the international filing date or priority date and not in conflict with the application but cited to understand the principle or theory underlying the invention

"X" document of particular relevance; the claimed invention cannot be considered novel or cannot be considered to involve an inventive step when the document is taken alone

"Y" document of particular relevance; the claimed invention cannot be considered to involve an inventive step when the document is combined with one or more other such documents, such combination being obvious to a person skilled in the art

"&amp;" document member of the same patent family

Date of the actual completion of the international search

**10 December 2018**

Date of mailing of the international search report

**29 December 2018**

Name and mailing address of the ISA/CN

**National Intellectual Property Administration, PRC**  
**6, Xitucheng Rd., Jimen Bridge, Haidian District, Beijing**  
**100088**  
**China**

Facsimile No. (86-10)62019451

Authorized officer

**WANG, Mengsi**

Telephone No. 86-(10)-53961642

**INTERNATIONAL SEARCH REPORT**  
**Information on patent family members**

International application No.

**PCT/CN2018/082064**

Patent document cited in search report			Publication date (day/month/year)	Patent family member(s)			Publication date (day/month/year)
CN	104429015	A	18 March 2015	CN	104412253	A	11 March 2015
				CN	104412646	A	11 March 2015
				FR	2994361	A1	07 February 2014
				ES	2444014	A2	21 February 2014
				WO	2014021989	A1	06 February 2014
				MX	2015000150	A	10 April 2015
				FR	3037470	A1	16 December 2016
				SE	1550515	A1	29 April 2015
				ES	2445833	A2	05 March 2014
				EP	2880782	A1	10 June 2015
				JP	2015526042	A	07 September 2015
				NL	2011265	A	04 February 2014
				WO	2014022847	A1	06 February 2014
				CN	107197421	A	22 September 2017
				AU	2016204197	A1	14 July 2016
				TW	201735714	A	01 October 2017
				CN	103582003	A	12 February 2014
				US	2018007572	A1	04 January 2018
				EP	2880548	A1	10 June 2015
				US	2017111898	A1	20 April 2017
				CA	2878195	A1	06 February 2014
				CN	106231615	A	14 December 2016
				ES	2513041	R1	18 November 2014
				IT	MI20131294	A1	04 February 2014
				KR	20160116042	A	06 October 2016
				FR	3047629	A1	11 August 2017
				EP	2880783	A1	10 June 2015
EP	2385647	A2	09 November 2011	CN	102237963	A	09 November 2011
				CN	102238641	A	09 November 2011
				CN	102237986	A	09 November 2011
				US	2012113909	A1	10 May 2012
				US	2012113962	A1	10 May 2012
				US	2012113910	A1	10 May 2012
				TW	201210239	A	01 March 2012
				EP	2385650	A2	09 November 2011
				EP	2385651	A2	09 November 2011
				TW	201210238	A	01 March 2012
				TW	201210292	A	01 March 2012
WO	2009100217	A2	13 August 2009	TW	200943879	A	16 October 2009
				US	2009201869	A1	13 August 2009
				CN	101939942	A	05 January 2011
				JP	2011511603	A	07 April 2011
				KR	20120084821	A	30 July 2012
				KR	20100126729	A	02 December 2010
				CA	2712913	A1	13 August 2009
				EP	2243244	A2	27 October 2010
				AU	2009212368	A1	13 August 2009
				RU	2010137350	A	20 March 2012
				MX	2010008679	A	31 August 2010
				CN	103532691	A	22 January 2014

**INTERNATIONAL SEARCH REPORT**  
**Information on patent family members**

International application No.

**PCT/CN2018/082064**

Patent document cited in search report	Publication date (day/month/year)	Patent family member(s)	Publication date (day/month/year)
		TW 201328275 A	01 July 2013
CN 101800620 A	11 August 2010	US 2012250648 A1	04 October 2012
		WO 2010149069 A1	29 December 2010