



AU9471581

(12) PATENT ABRIDGMENT (11) Document No. AU-B-71581/94
(19) AUSTRALIAN PATENT OFFICE (10) Acceptance No. 681895

- (54) Title
WASTE COLLECTION DEVICE
- International Patent Classification(s)
 (51)⁵ **B65F 001/12 B65D 088/54 B65D 090/66**
- (21) Application No. : **71581/94** (22) Application Date : **30.08.94**
- (30) Priority Data
- (31) Number (32) Date (33) Country
MN93A000015 07.09.93 IT ITALY
- (43) Publication Date : **23.03.95**
- (44) Publication Date of Accepted Application : **11.09.97**
- (71) Applicant(s)
GIANCARLO GALEAZZI; ANGELO FUSARO
- (72) Inventor(s)
GIANCARLO GALEAZZI; ANGELO FUSARO
- (74) Attorney or Agent
GRIFFITH HACK , GPO Box 4164, SYDNEY NSW 2001
- (56) Prior Art Documents
EP 480326
US 3708085
DE 1931163
- (57) Claim

1. Waste collection device comprising a pit provided with a lid that is openable and walkable in closed position at the level of the surrounding paving, a lifting unit that is suitable to move at least one waste container, which rests on a platform including said lifting unit, from a position in which it is fully inserted in the pit to a position in which it is fully extracted from it, said lid having a monolithic configuration and being provided with at least one pillar to allow users to insert waste into the at least one container, characterised in that said lid is associated with an upper edge of said pit by being pivoted thereto at one of its sides, and is kinematically connected to said lifting unit so as to perform the opening and closing motions respectively during the ascending and descending movements of the lifting unit, and in that said lifting unit comprises rising means, which are suitable to cause at least part of the rising motion of the lid before the ascending motion of the platform that supports the at least one waste container has begun, and



(11) AU-B-71581/94
(10) 681895

-2-

to complete the closing motion of the lid only after said platform has reached the lower stroke limit.

AUSTRALIA
Patents Act 1990

ORIGINAL
COMPLETE SPECIFICATION
STANDARD PATENT

Invention Title: WASTE COLLECTION DEVICE

The following statement is a full description of this invention, including the best method of performing it known to us:

GH&CO REF: P23473-A:CAS:RK

WASTE COLLECTION DEVICE

The invention relates to a waste collection device.

It is known that collection of municipal solid waste performed by means of roadside containers entails considerable disadvantages from the aesthetic and hygienic viewpoints as well as due to the space occupied by these containers.

In order to obviate these drawbacks, devices have been devised in which the waste containers are stored in a pit which is closed at the top by a lid which has pillars for the insertion of waste; the containers are caused to rise from the pit only when they must be emptied.

These devices have excellent functionality, but new studies have led to the creation of the device to which the present invention relates.

The aim of said device is to maximally facilitate the operations for emptying the containers, particularly when they are handled automatically by devices connected to the collection trucks with a single operator on board.

According to the present invention there is provided a waste collection device comprising a pit provided with a lid that is openable and walkable in closed position at the level of the surrounding paving, a lifting unit that is suitable to move at least one waste container, which rests on a platform including said lifting unit, from a position in which it is fully inserted in the pit to a position in which it is fully extracted from it, said lid, having a monolithic configuration and being provided with at least one pillar to allow users to insert waste into the at least one container, characterised in that said lid is associated with an upper edge of said pit by being pivoted thereto at one of its sides, and is kinematically connected to said lifting unit so as to perform the opening and closing motions respectively during the ascending and descending movements of the lifting unit, and in that said lifting unit comprises rising means, which are suitable to cause at least part



of the rising motion of the lid before the ascending motion of the platform that supports the at least one waste container has begun, and to complete the closing motion of the lid only after said platform has reached the lower stroke limit.

5 The characteristics and advantages of the invention will become apparent from the following detailed description of a preferred embodiment but not exclusive embodiment thereof, illustrated only by way of non-

10 limitative example in the accompanying drawings, wherein:

Figure 1 is a perspective view of the device according to the invention, with the lid closed and the lifting unit at its lower stroke limit;

15 Figure 2 is a sectional view, taken along the plane II-II of Figure 1;

Figures 3 and 4 are views, similar to Figure 2, of the device according to the invention with the lid and the lifting unit respectively in an intermediate position of their stroke and at the upper stroke limit.

20 With reference to the above figures, the reference numeral 1 designates a pit provided with a monolithic lid 2 that comprises pillars 3 and 4 that allow users to insert the waste, optionally in bags, respectively into containers, designated by the reference numerals 3a and 4a, which will be described hereinafter.

25 Said lid is pivoted to the upper edge of the pit at 5 and 6, and is kinematically connected to a lifting unit.



contained in the pit, which will be described hereafter, so as to move between the closed position shown in figures 1 and 2, at the level of the paving 7 that surrounds the pit 1, and the fully open position shown in figure 4.

5 The lifting unit contained in the pit 1 thus comprises a first section which is constituted by two sliders which are formed respectively by uprights 8a and 8b, connected by cross-members 8c and 8d, and by the uprights 9a and 9b, connected by cross-members 9c and 9d.

10 A guide 8e is rigidly coupled to the first slider and is inclined with respect to the vertical direction of the motion; a wheel 10 runs inside said guide and is rigidly coupled to the lid 2 by means of a support 10a; a guide 9e is rigidly coupled to the second slider and is inclined like
15 8e, and a wheel 11 runs inside said guide 9e and is rigidly coupled to the lid 2 by means of a support 11a; this kinematic linkage causes each vertical movement of the sliders that form the first section to be matched by a rotation of the lid 2.

20 Said sliders that constitute the first section have actuation means which are respectively constituted by actuation cylinders 12 and 13, the end of whose stem is indeed connected to the inclined guides 8e, 9e; said actuation cylinders rest respectively on bases 14 and 15
25 which are fixed to the bottom of the pit 1 and from which fixed uprights 14a, 14b and 15a, 15b rise, and are fixed to cross-members 16 and 17 that respectively connect said fixed uprights 14a, 14b and 15a, 15b.

In addition to the first described section, the lifting
30 unit comprises a second section which is constituted by two

sliders formed respectively by uprights 18a and 18b, connected by cross-members 18c and 18d, and by uprights 19a and 19b, connected by cross-members 19c and 19d; the platform 20 for supporting the waste containers 3a and 4a is rigidly coupled to said sliders.

The uprights 18a, 18b constitute the guides for the sliding of the uprights 8a and 8b and slide with respect to the fixed uprights 14a, 14b; in turn, the uprights 19a, 19b constitute the guides for the sliding of the uprights 9a and 9b and slide with respect to the fixed uprights 15a, 15b.

In terms of the functionality of the invention it is important to consider the fact that the cross-member 8c of a slider of the first section lies in the same plane as the cross-member 18c of a slider of the second section, and that in a similar manner the cross-member 9c lies in the same plane as the cross-member 19c.

While postponing further details to the description of operation, it is now sufficient to note that in this manner said cross-members 8c and 9c act as abutment elements which are suitable to make contact with complementarily shaped elements constituted by the cross-members 18c and 19c after a first part of the ascending motion to disengage from them before the last part of the descending motion.

The operation of the invention is now described starting from the position shown in figures 1 and 2.

When it is necessary to make the containers 3a, 4a rise from the pit to empty them, the actuation cylinders 12 and 13 are activated and in a first part of the extension of their stem simply cause the ascent of the first section of the lifting unit, i.e. of the section that comprises the

sliders with the inclined guides 8e and 9e, so that at the same time the lid 2 starts to rise, while the container supporting platform 20 is motionless, thus preventing the containers 3a, 4a from colliding against the lid 2, as would occur if they started to rise together with the lid.

At a certain point during the ascending motion of the first section, the lid is open enough to allow the containers 3a, 4a to start to rise without problems; at this point the cross-members 8c and 9c of the sliders of said first section make contact with the lower edge of the cross-members 18c and 19c of the second section, which comprises the container supporting platform 20.

In this manner, said section is moved upwards, as shown in figure 3, until the position shown in figure 4 is reached, with the lid completely open and the platform 20 at the level of the paving that surrounds the pit 1.

During the descending motion, the two sections move together until the uprights 18a, 18b and 19a, 19b of the second section rest on the bases 14 and 15 and stop, whereas the downward motion of the first section continues, losing contact between the cross-members 8c and 18c and between the cross-members 9c and 19c, in order to complete the closure of the lid.

The described invention is susceptible to numerous modifications and variations, all of which are within the scope of the inventive concept; all the details may furthermore be replaced with other technically equivalent elements.

In the practical embodiment of the invention, the materials employed, as well as the shapes and dimensions,

THE CLAIMS DEFINING THE INVENTION ARE AS FOLLOWS:

1. Waste collection device comprising a pit provided with a lid that is openable and walkable in closed position at the level of the surrounding paving, a
5 lifting unit that is suitable to move at least one waste container, which rests on a platform including said lifting unit, from a position in which it is fully inserted in the pit to a position in which it is fully
10 extracted from it, said lid having a monolithic configuration and being provided with at least one pillar to allow users to insert waste into the at least one
15 container, characterised in that said lid is associated with an upper edge of said pit by being pivoted thereto at one of its sides, and is kinematically connected to
20 said lifting unit so as to perform the opening and closing motions respectively during the ascending and descending movements of the lifting unit, and in that said lifting unit comprises rising means, which are
suitable to cause at least part of the rising motion of the lid before the ascending motion of the platform that supports the at least one waste container has begun, and to complete the closing motion of the lid only after said
platform has reached the lower stroke limit.

2. Device according to claim 1, characterised in
25 that said rising means comprise a first section actuatable in a first phase ascending motion for gradually raising the lid while said platform remains motionless, and a second section actuatable in a second
30 phase ascending motion, jointly with said first section, after said lid has opened so as to prevent collision with a rising said at least one container, said first and second sections being further actuatable for a two-phase
35 descending motion also, in a first one of which the two sections are moving jointly for lowering the at least one container, and a second one in which the second section remains motionless with said platform at said lower stroke limit and the first section moves downward for completing closure of the lid.



3. Device according to one or more of the preceding claims, characterised in that said first section has actuation means and is connected to the lid so that each movement thereof is matched by a movement of said lid, said first section being suitable to move rigidly with said second section, which includes said platform for supporting at least one container, only above a certain level with respect to the lower stroke limit.

4. Device according to one or more of the preceding claims, characterised in that the first section of the lifting unit has guides, which are inclined with respect to the direction of motion and are associated with wheels, rigidly coupled to the lid, and has abutment elements which are suitable to make contact with complementarily shaped elements which are rigidly coupled to the second section only after a first portion of the ascending motion to disengage them before the last portion of the descending motion, so as to move said second section during contact.

5. A waste collection device substantially as hereinbefore described with reference to the accompanying drawings.

Dated this 23rd day of April 1997
GIANCARLO GALEAZZI and ANGELO FUSARO
By their Patent Attorneys
GRIFFITH HACK



WASTE COLLECTION DEVICE

ABSTRACT

Waste collection device that includes a pit (1) provided with a lid (2) that has waste insertion pillars (3,4) and with a lifting unit (8-19) that is suitable to move at least one waste container (3a,4a); the device is characterized in that the monolithic lid is pivoted (5,6) to the edge of the pit and is kinematically connected to the lifting unit so as to perform the opening and closing motions respectively during the ascending and descending movements of the lifting unit.

(Figure 1)

Fig. 2

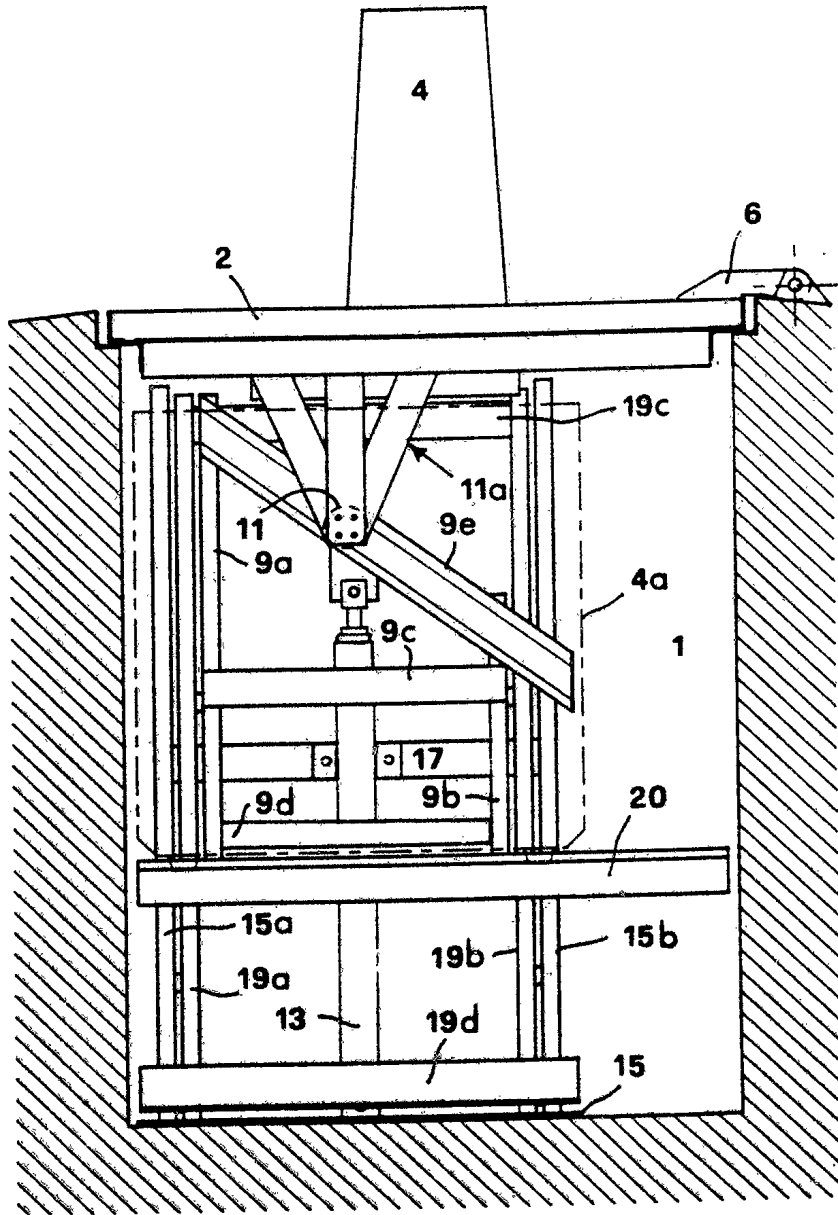

Fig. 3

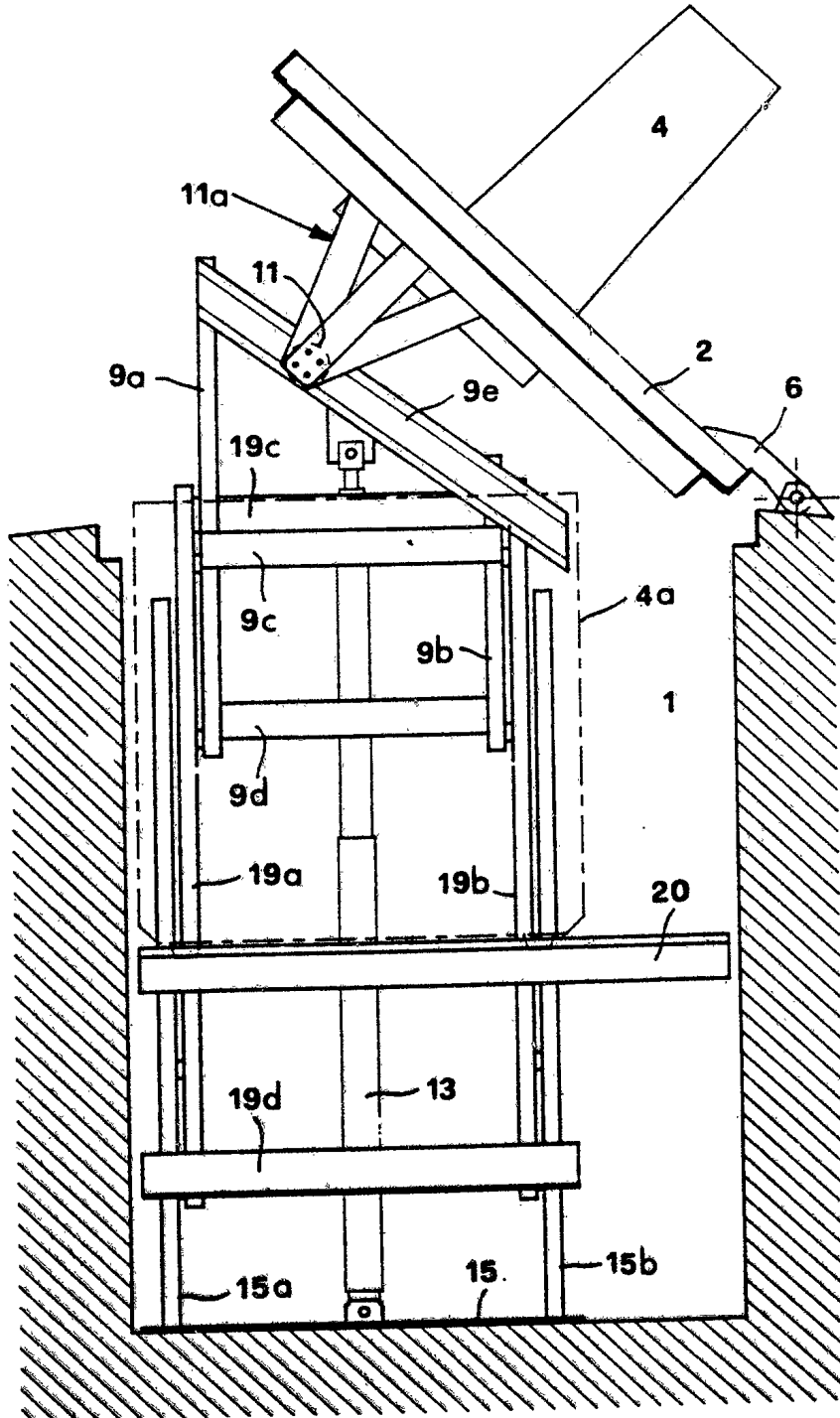

Fig. 4

