



(51) International Patent Classification:

A61B 18/14 (2006.01) A61B 18/00 (2006.01)
A61B 18/12 (2006.01) A61B 90/00 (2016.01)
A61B 17/32 (2006.01)

(21) International Application Number:

PCT/US2016/052984

(22) International Filing Date:

22 September 2016 (22.09.2016)

(25) Filing Language:

English

(26) Publication Language:

English

(30) Priority Data:

62/235,368 30 September 2015 (30.09.2015) US
15/258,598 7 September 2016 (07.09.2016) US

(71) Applicant: **ETHICON ENDO-SURGERY, LLC**
[US/US]; #475 Street C, Los Frailes Industrial Park,
Guaynabo, PUERTO RICO 00969 (US).

(72) Inventors: **WIENER, Eitan T.**; 4545 Creek Road, Cincinnati, Ohio 45242 (US). **YATES, David C.**; 4545 Creek Road, Cincinnati, Ohio 45242 (US). **ASHER, Ryan M.**; 4545 Creek Road, Cincinnati, Ohio 45242 (US). **HIBNER, John A.**; 4545 Creek Road, Cincinnati, Ohio 45242 (US).

(74) Agents: **SHIRTZ, Joseph F.** et al.; Johnson & Johnson, One Johnson & Johnson Plaza, New Brunswick, New Jersey 08933 (US).

(81) Designated States (unless otherwise indicated, for every kind of national protection available): AE, AG, AL, AM, AO, AT, AU, AZ, BA, BB, BG, BH, BN, BR, BW, BY, BZ, CA, CH, CL, CN, CO, CR, CU, CZ, DE, DK, DM, DO, DZ, EC, EE, EG, ES, FI, GB, GD, GE, GH, GM, GT, HN, HR, HU, ID, IL, IN, IR, IS, JP, KE, KG, KN, KP, KR, KW, KZ, LA, LC, LK, LR, LS, LU, LY, MA, MD, ME, MG, MK, MN, MW, MX, MY, MZ, NA, NG, NI, NO, NZ, OM, PA, PE, PG, PH, PL, PT, QA, RO, RS, RU, RW, SA, SC, SD, SE, SG, SK, SL, SM, ST, SV, SY, TH, TJ, TM, TN, TR, TT, TZ, UA, UG, US, UZ, VC, VN, ZA, ZM, ZW.

(84) Designated States (unless otherwise indicated, for every kind of regional protection available): ARIPO (BW, GH, GM, KE, LR, LS, MW, MZ, NA, RW, SD, SL, ST, SZ, TZ, UG, ZM, ZW), Eurasian (AM, AZ, BY, KG, KZ, RU, TJ, TM), European (AL, AT, BE, BG, CH, CY, CZ, DE, DK, EE, ES, FI, FR, GB, GR, HR, HU, IE, IS, IT, LT, LU, LV, MC, MK, MT, NL, NO, PL, PT, RO, RS, SE, SI, SK, SM, TR), OAPI (BF, BJ, CF, CG, CI, CM, GA, GN, GQ, GW, KM, ML, MR, NE, SN, TD, TG).

Published:

— with international search report (Art. 21(3))

(54) Title: METHOD AND APPARATUS FOR SELECTING OPERATIONS OF A SURGICAL INSTRUMENT BASED ON USER INTENTION

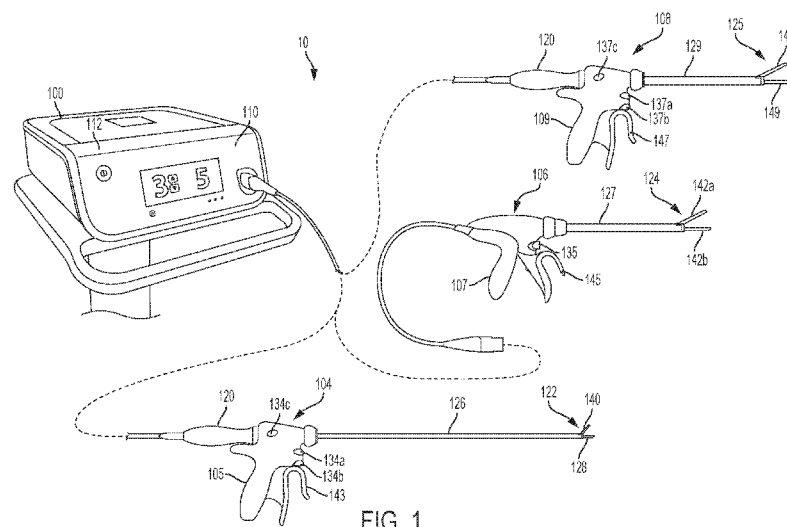

FIG. 1

(57) Abstract: Disclosed is a method for operating a surgical instrument, the surgical instrument comprising a radio frequency (RF) energy output, an ultrasonic energy output, and a first jaw and a second jaw configured for pivotal movement between a closed position and an open position, the method comprising: receiving a first input indicating a user selection of one of a first option and a second option; receiving a second input indicating whether the first jaw and the second jaw are in the closed position or in the open position; receiving a third input indicating electrical impedance at the RF energy output; and selecting a mode of operation for treating a tissue from a plurality of modes of operation based at least in part on the first input, the second input and the third input.



METHOD AND APPARATUS FOR SELECTING OPERATIONS OF A SURGICAL INSTRUMENT BASED ON USER INTENTION

PRIORITY

[0001] This application claims the benefit of U.S. Provisional Application Serial No. 62/235,260, titled GENERATOR FOR PROVIDING COMBINED RADIO FREQUENCY AND ULTRASONIC ENERGIES, filed September 30, 2015, U.S. Provisional Application Serial No. 62/235,368, titled CIRCUIT TOPOLOGIES FOR GENERATOR, filed September 30, 2015, and U.S. Provisional Application Serial No. 62/235,466, titled SURGICAL INSTRUMENT WITH USER ADAPTABLE ALGORITHMS, filed September 30, 2015, the contents of each of which are incorporated herein by reference in their entirety.

TECHNICAL FIELD

[0002] The present disclosure generally relates to ultrasonic surgical systems, electrosurgical systems, and combination electrosurgical/ultrasonic systems for performing surgical procedures such as coagulating, sealing, and/or cutting tissue. In particular, the present disclosure relates to method and apparatus for selecting operations of a surgical instrument based on user intention.

BACKGROUND

[0003] Ultrasonic surgical instruments are finding increasingly widespread applications in surgical procedures by virtue of the unique performance characteristics of such instruments. Depending upon specific instrument configurations and operational parameters, ultrasonic surgical instruments can provide substantially simultaneous cutting of tissue and hemostasis by coagulation, desirably minimizing patient trauma. The cutting action is typically realized by an end effector, or blade tip, at the distal end of the instrument, which transmits ultrasonic energy to tissue brought into contact with the end effector. Ultrasonic instruments of this nature can be configured for open surgical use, laparoscopic, or endoscopic surgical procedures including robotic-assisted procedures.

[0004] Some surgical instruments utilize ultrasonic energy for both precise cutting and controlled coagulation. Ultrasonic energy cuts and coagulates by vibrating a blade in contact with tissue. Vibrating at high frequencies (*e.g.*, 55,500 times per second), the ultrasonic blade denatures protein in the tissue to form a sticky coagulum. Pressure exerted on tissue with the

blade surface collapses blood vessels and allows the coagulum to form a hemostatic seal. The precision of cutting and coagulation is controlled by the surgeon's technique and adjusting the power level, blade edge, tissue traction, and blade pressure.

[0005] Electrosurgical devices for applying electrical energy to tissue in order to treat and/or destroy the tissue are also finding increasingly widespread applications in surgical procedures. An electrosurgical device typically includes a hand piece, an instrument having a distally-mounted end effector (*e.g.*, one or more electrodes). The end effector can be positioned against the tissue such that electrical current is introduced into the tissue. Electrosurgical devices can be configured for bipolar or monopolar operation. During bipolar operation, current is introduced into and returned from the tissue by active and return electrodes, respectively, of the end effector. During monopolar operation, current is introduced into the tissue by an active electrode of the end effector and returned through a return electrode (*e.g.*, a grounding pad) separately located on a patient's body. Heat generated by the current flowing through the tissue may form hemostatic seals within the tissue and/or between tissues and thus may be particularly useful for sealing blood vessels, for example. The end effector of an electrosurgical device may also include a cutting member that is movable relative to the tissue and the electrodes to transect the tissue.

[0006] Electrical energy applied by an electrosurgical device can be transmitted to the instrument by a generator in communication with the hand piece. The electrical energy may be in the form of RF energy that may be in a frequency range described in EN 60601-2-2:2009+A11:2011, Definition 201.3.218 – HIGH FREQUENCY. For example, the frequencies in monopolar RF applications are typically restricted to less than 5MHz. However, in bipolar RF applications, the frequency can be almost anything. Frequencies above 200 kHz can be typically used for MONOPOLAR applications in order to avoid the unwanted stimulation of nerves and muscles which would result from the use of low frequency current. Lower frequencies may be used for BIPOLAR techniques if the RISK ANALYSIS shows the possibility of neuromuscular stimulation has been mitigated to an acceptable level. Normally, frequencies above 5 MHz are not used in order to minimize the problems associated with HIGH FREQUENCY LEAKAGE CURRENTS. However, higher frequencies may be used in the case of BIPOLAR techniques. It is generally recognized that 10 mA is the lower threshold of thermal effects on tissue.

[0007] In application, an electrosurgical device can transmit low frequency RF energy through tissue, which causes ionic agitation, or friction, in effect resistive heating, thereby increasing the temperature of the tissue. Because a sharp boundary is created between the affected tissue and the surrounding tissue, surgeons can operate with a high level of precision and control, without sacrificing un-targeted adjacent tissue. The low operating temperatures of RF energy is useful for removing, shrinking, or sculpting soft tissue while simultaneously sealing blood vessels. RF energy works particularly well on connective tissue, which is primarily comprised of collagen and shrinks when contacted by heat.

[0008] Other electrical surgical instruments include, without limitation, irreversible and/or reversible electroporation, and/or microwave technologies, among others. Accordingly, the techniques disclosed herein are applicable to ultrasonic, bipolar or monopolar RF (electrosurgical), irreversible and/or reversible electroporation, and/or microwave based surgical instruments, among others.

SUMMARY

[0009] In one aspect, a method for operating a surgical instrument is provided, the surgical instrument comprising a radio frequency (RF) energy output, an ultrasonic energy output, and a first jaw and a second jaw configured for pivotal movement between a closed position and an open position, the method comprising: receiving a first input indicating a user selection of one of a first option and a second option; receiving a second input indicating whether the first jaw and the second jaw are in the closed position or in the open position; receiving a third input indicating electrical impedance at the RF energy output; and selecting a mode of operation for treating a tissue from a plurality of modes of operation based at least in part on the first input, the second input and the third input, wherein the plurality of modes of operation comprises: a first mode wherein the RF energy output applies RF energy to the tissue; and a second mode wherein the ultrasonic energy output applies ultrasonic energy to the tissue.

[0010] In another aspect, a generator for delivering radio frequency (RF) energy and ultrasonic energy to a surgical instrument is provided, the surgical instrument comprising a first jaw and a second jaw configured for pivotal movement between a closed position and an open position, the generator being configured to: receive a first input indicating a user selection of one of a first option and a second option; receive a second input indicating whether the first jaw and the second jaw are in the closed position or in the open position; receive a third input indicating

electrical impedance at a RF energy output of the surgical instrument; and select a mode of operation for treating a tissue from a plurality of modes of operation based at least in part on the first input, the second input and the third input, wherein the plurality of modes of operation comprises: a first mode wherein the generator delivers RF energy to the surgical instrument; and a second mode wherein the generator delivers ultrasonic energy to the surgical instrument.

[0011] In yet another aspect, a surgical instrument is provided comprising: a first jaw and a second jaw configured for pivotal movement between a closed position and an open position; a radio frequency (RF) energy output configured to apply RF energy to a tissue at least when a first mode of operation is selected; and an ultrasonic energy output configured to apply ultrasonic energy to the tissue at least when a second mode of operation is selected, wherein a mode of operation is selected from a plurality of modes of operation comprising the first mode and the second mode based at least in part on a first input, a second input and a third input, wherein: the first input indicates a user selection of one of a first option and a second option; the second input indicates whether the first jaw and the second jaw are in the closed position or in the open position; and the third input indicates electrical impedance at the RF energy output.

FIGURES

[0012] The novel features of the described forms are set forth with particularity in the appended claims. The described forms, however, both as to organization and methods of operation, may be best understood by reference to the following description, taken in conjunction with the accompanying drawings in which:

[0013] FIG. 1 illustrates one form of a surgical system comprising a generator and various surgical instruments usable therewith;

[0014] FIG. 2 is a diagram of the combination electrosurgical and ultrasonic instrument shown in FIG. 1;

[0015] FIG. 3 is a diagram of the surgical system shown in FIG. 1;

[0016] FIG. 4 is a model illustrating motional branch current in one form;

[0017] FIG. 5 is a structural view of a generator architecture in one form;

[0018] FIG. 6 illustrates one form of a drive system of a generator, which creates the ultrasonic electrical signal for driving an ultrasonic transducer;

[0019] FIG. 7 illustrates one form of a drive system of a generator comprising a tissue impedance module;

[0020] FIG. 8 illustrates an example of a combined radio frequency and ultrasonic energy generator for delivering energy to a surgical instrument;

[0021] FIG. 9 is a diagram of a system for delivering combined radio frequency and ultrasonic energy to a plurality of surgical instruments;

[0022] FIG. 10 illustrates a communications architecture of a system for delivering combined radio frequency and ultrasonic energy to a plurality of surgical instruments;

[0023] FIG. 11 illustrates a communications architecture of a system for delivering combined radio frequency and ultrasonic energy to a plurality of surgical instruments;

[0024] FIG. 12 illustrates a communications architecture of a system for delivering combined radio frequency and ultrasonic energy to a plurality of surgical instruments;

[0025] FIG. 13 shows a block diagram illustrating the selection of operations of a surgical instrument based on various inputs;

[0026] FIG. 14 shows a logic diagram illustrating specific operations of a surgical instrument selected based on various inputs;

[0027] FIG. 15 provides an illustration of a system configuration for an example circuit topology shown and described with regard to FIGS. 13-14, including metal-oxide semiconductor field effect transistor (MOSFET) switches and a control circuit in the handle, configured to manage RF and ultrasonic currents output by a generator according to one aspect of the present disclosure;

[0028] FIG. 16 provides an illustration of a system configuration for an example circuit topology shown and described with regard to FIGS. 13-14, including bandstop filters and a control circuit in the handle, configured to manage RF and ultrasonic currents output by a generator according to one aspect of the present disclosure;

[0029] FIG. 17 is an example graph of two waveforms of energy from a generator;

[0030] FIG. 18 is an example graph of the sum of the waveforms of FIG. 17;

[0031] FIG. 19 is an example graph of sum of the waveforms of FIG. 17 with the RF waveform dependent on the ultrasonic waveform;

[0032] FIG. 20 is an example graph of the sum of the waveforms of FIG. 17 with the RF waveform being a function of the ultrasonic waveform; and

[0033] FIG. 21 is an example graph of a complex RF waveform with a high crest factor.

DESCRIPTION

[0034] Before explaining various forms of ultrasonic surgical instruments in detail, it should be noted that the illustrative forms are not limited in application or use to the details of construction and arrangement of parts illustrated in the accompanying drawings and description. The illustrative forms may be implemented or incorporated in other forms, variations and modifications, and may be practiced or carried out in various ways. Further, unless otherwise indicated, the terms and expressions employed herein have been chosen for the purpose of describing the illustrative forms for the convenience of the reader and are not for the purpose of limitation thereof.

[0035] Further, it is understood that any one or more of the following-described forms, expressions of forms, examples, can be combined with any one or more of the other following-described forms, expressions of forms, and examples.

[0036] Various forms are directed to improved ultrasonic surgical instruments configured for effecting tissue dissecting, cutting, and/or coagulation during surgical procedures. In one form, an ultrasonic surgical instrument apparatus is configured for use in open surgical procedures, but has applications in other types of surgery, such as laparoscopic, endoscopic, and robotic-assisted procedures. Versatile use is facilitated by selective use of ultrasonic energy.

[0037] This application is related to the following commonly owned patent applications filed contemporaneously herewith:

Attorney Docket No. END7768USNP1/150449-1, titled CIRCUIT TOPOLOGIES FOR COMBINED GENERATOR, by Wiener et al.;

Attorney Docket No. END7768USNP2/150449-2, titled CIRCUITS FOR SUPPLYING ISOLATED DIRECT CURRENT (DC) VOLTAGE TO SURGICAL INSTRUMENTS, by Wiener et al.;

Attorney Docket No. END7768USNP3/150449-3, titled FREQUENCY AGILE GENERATOR FOR A SURGICAL INSTRUMENT, by Yates et al.;

Attorney Docket No. END7769USNP1/150448-1, titled GENERATOR FOR DIGITALLY GENERATING ELECTRICAL SIGNAL WAVEFORMS FOR ELECTROSURGICAL AND ULTRASONIC SURGICAL INSTRUMENTS, by Wiener et al.;

Attorney Docket No. END7769USNP2/150448-2, titled GENERATOR FOR DIGITALLY GENERATING COMBINED ELECTRICAL SIGNAL WAVEFORMS FOR ULTRASONIC SURGICAL INSTRUMENTS, by Wiener et al.;

Attorney Docket No. END7769USNP3/150448-3, titled PROTECTION TECHNIQUES FOR GENERATOR FOR DIGITALLY GENERATING ELECTROSURGICAL AND ULTRASONIC DIGITAL ELECTRICAL SIGNAL WAVEFORMS, by Yates et al.;

each of which is incorporated herein by reference in its entirety.

[0038] This application also is related to the following commonly owned patent applications filed on June 9, 2016:

U.S. Patent Application No. 15/177,430, titled SURGICAL INSTRUMENT WITH USER ADAPTABLE TECHNIQUES;

U.S. Patent Application No. 15/177,439, titled SURGICAL INSTRUMENT WITH USER ADAPTABLE TECHNIQUES BASED ON TISSUE TYPE;

U.S. Patent Application No. 15/177,449, titled SURGICAL SYSTEM WITH USER ADAPTABLE TECHNIQUES EMPLOYING MULTIPLE ENERGY MODALITIES BASED ON TISSUE;

U.S. Patent Application No. 15/177,456, titled SURGICAL SYSTEM WITH USER ADAPTABLE TECHNIQUES BASED ON TISSUE IMPEDANCE;

U.S. Patent Application No. 15/177,466, titled SURGICAL SYSTEM WITH USER ADAPTABLE TECHNIQUES EMPLOYING SIMULTANEOUS ENERGY MODALITIES BASED ON TISSUE PARAMETERS;

each of which is incorporated herein by reference in its entirety.

[0039] The various forms will be described in combination with an ultrasonic instrument as described herein. Such description is provided by way of example, and not limitation, and is not intended to limit the scope and applications thereof. For example, any one of the described forms is useful in combination with a multitude of ultrasonic instruments including those described in, for example, U.S. Patent Nos. 5,938,633; 5,935,144; 5,944,737; 5,322,055; 5,630,420; and 5,449,370, which are each incorporated by reference herein in their entirety.

[0040] As will become apparent from the following description, it is contemplated that forms of the surgical instrument described herein may be used in association with an oscillator unit of a surgical system, whereby ultrasonic energy from the oscillator unit provides the desired ultrasonic actuation for the present surgical instrument. It is also contemplated that forms of the surgical instrument described herein may be used in association with a signal generator unit of a surgical system, whereby electrical energy in the form of radio frequencies (RF), for example, is used to provide feedback to the user regarding the surgical instrument. The ultrasonic oscillator and/or the signal generator unit may be non-detachably integrated with the surgical instrument or may be provided as separate components, which can be electrically attachable to the surgical instrument.

[0041] One form of the present surgical apparatus is particularly configured for disposable use by virtue of its straightforward construction. However, it is also contemplated that other forms of the present surgical instrument can be configured for non-disposable or multiple uses. Detachable connection of the present surgical instrument with an associated oscillator and signal generator unit is presently disclosed for single-patient use for illustrative purposes only. However, non-detachable integrated connection of the present surgical instrument with an associated oscillator and/or signal generator unit is also contemplated. Accordingly, various forms of the presently described surgical instruments may be configured for single use and/or multiple use with either detachable and/or non-detachable integral oscillator and/or signal generator unit, without limitation, and all combinations of such configurations are contemplated to be within the scope of the present disclosure.

[0042] In one aspect, the desired wave shape may be digitized by 1024 points, which are stored in a table, such as, for example, a DDS table (Direct Digital Synthesis table) with a FPGA (Field Programmable Gate Array) of the generator. The generator software and digital controls command the FPGA to scan the addresses in this table at the frequency of interest which in turn provides varying digital input values to a DAC that feeds to power amplifier. This method enables generating practically any (or many) types of wave shapes fed into tissue. Furthermore, multiple wave shape tables can be created, stored and applied to tissue.

[0043] According to various aspects, a method comprises creating various types of lookup tables in memory such as lookup tables generated by Direct Digital Synthesizers (DDS) and stored within Field Programmable Gate Arrays (FPGA), for example. Waveforms may be stored in the DDS table or tables as particular wave shapes. Examples of wave shapes in the RF/Electrosurgery tissue treatment field include high crest factor RF signals, which may be used for surface coagulation in an RF mode, for example, low crest factor RF signals, which may be used for deeper penetration into tissue in an RF mode, for example, and waveforms that promote efficient touch-up coagulation, for example.

[0044] The present disclosure provides for the creation of multiple wave shape tables that allow for switching on the fly, either manually or automatically, between the wave shapes based on tissue effect desired. Switching could be based on tissue parameters, such as, for example, tissue impedance and/or other factors. In addition to a traditional sine wave shape, in one aspect a generator may be configured to provide a wave shape that maximizes the power into tissue per cycle. According to one aspect, the wave shape may be a trapezoid wave, a sine or cosine wave, a square wave, a triangle wave, or any combination thereof. In one aspect, a generator may be configured to provide a wave shape or shapes that are synchronized in such way that they make maximizing power delivery in the case that both RF and ultrasonic energy modalities are driven, either simultaneously or sequentially. In one aspect, a generator may be configured to provide a waveform that drives both ultrasonic and RF therapeutic energy simultaneously while maintaining ultrasonic frequency lock. In one aspect, the generator may contain or be associated with a device that provides a circuit topology that enables simultaneously driving RF and ultrasonic energy. In one aspect, a generator may be configured to provide custom wave shapes that are specific to a surgical instrument and the tissue effects provided by such a surgical instrument. Furthermore, the waveforms may be stored in a generator non-volatile memory or in an instrument memory, such as, for example, an EEPROM. The waveform or waveforms may be fetched upon instrument connection to a generator.

[0045] With reference to FIGS. 1-5, one form of a surgical system 1000 including an ultrasonic surgical instrument is illustrated. FIG. 1 illustrates one form of a surgical system 1000 comprising a generator 100 and various surgical instruments 104, 106, 108 usable therewith. FIG. 2 is a diagram of the ultrasonic surgical instrument 108 shown in FIG. 1. With reference to both FIGS. 1 and 2, the generator 100 is configurable for use with a variety of surgical instruments.

[0046] According to various forms, the generator 100 may be configurable for use with different surgical instruments of different types including, for example, the ultrasonic device 104, electrosurgical or RF surgical instruments, such as, the RF device 106, and multifunction devices 108 that integrate electrosurgical RF and ultrasonic energies delivered simultaneously from the generator 100. Although in the form of FIG. 1, the generator 100 is shown separate from the surgical instruments 104, 106, 108 in one form, the generator 100 may be formed integrally with either of the surgical instruments 104, 106, 108 to form a unitary surgical system. The generator 100 comprises an input device 112 located on a front panel of the generator 100 console. The input device 112 may comprise any suitable device that generates signals suitable for programming the operation of the generator 100.

[0047] FIG. 1 illustrates a generator 100 configured to drive multiple surgical instruments 104, 106, 108. The first surgical instrument 104 comprises a handpiece 105, an ultrasonic transducer 120, a shaft 126, and an end effector 122. The end effector 122 comprises an ultrasonic blade 128 acoustically coupled to the transducer 120 and a clamp arm 140. The handpiece 105 comprises a trigger 143 to operate the clamp arm 140 and a combination of the toggle buttons 134a, 134b, 134c to energize and drive the ultrasonic blade 128 or other function. The toggle buttons 134a, 134b, 134c can be configured to energize the ultrasonic transducer 120 with the generator 100.

[0048] Still with reference to FIG. 1, the generator 100 also is configured to drive a second surgical instrument 106. The second surgical instrument 106 is an RF electrosurgical instrument and comprises a handpiece 107, a shaft 127, and an end effector 124. The end effector 124 comprises electrodes in the clamp arms 143 and return through the ultrasonic blade 149. The electrodes are coupled to and energized by a bipolar energy source within the generator 100. The handpiece 107 comprises a trigger 147 to operate the clamp arm 145 and an energy button 135 to actuate an energy switch to energize the electrodes in the end effector 124.

[0049] Still with reference to FIG. 1, the generator 100 also is configured to drive a combination electrosurgical and ultrasonic instrument 108. The combination electrosurgical and ultrasonic multifunction surgical instrument 108 comprises a handpiece 109, a shaft 129, and an end effector 125. The end effector 125 comprises an ultrasonic blade 149 and a clamp arm 146. The ultrasonic blade 149 is acoustically coupled to the ultrasonic transducer 120. The handpiece 109 comprises a trigger 147 to operate the clamp arm 146 and a combination of the toggle buttons 137a, 137b, 137c to energize and drive the ultrasonic blade 149 or other function. The toggle buttons 137a, 137b, 137c can be configured to energize the ultrasonic transducer 120 with the generator 100 and energize the ultrasonic blade 149 with a bipolar energy source also contained within the generator 100.

[0050] With reference to both FIGS. 1 and 2, the generator 100 is configurable for use with a variety of surgical instruments. According to various forms, the generator 100 may be configurable for use with different surgical instruments of different types including, for example, the ultrasonic surgical instrument 104, the electrosurgical or RF surgical instruments, such as, the RF electrosurgical instrument 106, and the multifunction surgical instrument 108 that integrate electrosurgical RF and ultrasonic energies delivered simultaneously from the generator 100. Although in the form of FIG. 1, the generator 100 is shown separate from the surgical instruments 104, 106, 108, in one form, the generator 100 may be formed integrally with either of the surgical instrument 104, 106, 108 to form a unitary surgical system. The generator 100 comprises an input device 110 located on a front panel of the generator 100 console. The input device 110 may comprise any suitable device that generates signals suitable for programming the operation of the generator 100. The generator 100 also may comprise one or more output devices 112.

[0051] With reference now to FIG. 2, the generator 100 is coupled to the combination electrosurgical and ultrasonic multifunction surgical instrument 108. The generator 100 is coupled to the ultrasonic transducer 120 via a cable 144. The ultrasonic transducer 120 and a waveguide extending through a shaft 129 (waveguide not shown in FIG. 2) may collectively form an ultrasonic drive system driving an ultrasonic blade 149 of an end effector 125. The end effector 125 further may comprise a clamp arm 146 to clamp tissue located between the clamp arm 146 and the ultrasonic blade 149. In one form, the generator 100 may be configured to produce a drive signal of a particular voltage, current, and/or frequency output signal that can be stepped or otherwise modified with high resolution, accuracy, and repeatability.

[0052] Still with reference to FIG. 2, It will be appreciated that the surgical instrument 108 may comprise any combination of the toggle buttons 137a, 137b, 134c. For example, the surgical instrument 104 could be configured to have only two toggle buttons: a toggle button 134a for producing maximum ultrasonic energy output and a toggle button 134c for producing a pulsed output at either the maximum or less than maximum power level. In this way, the drive signal output configuration of the generator 100 could be 5 continuous signals and 5 or 4 or 3 or 2 or 1 pulsed signals. In certain forms, the specific drive signal configuration may be controlled based upon, for example, EEPROM settings in the generator 100 and/or user power level selection(s).

[0053] In certain forms, a two-position switch may be provided as an alternative to a toggle button 134c. For example, a surgical instrument 104 may include a toggle button 134a for producing a continuous output at a maximum power level and a two-position toggle button 134b. In a first detented position, toggle button 134b may produce a continuous output at a less than maximum power level, and in a second detented position the toggle button 134b may produce a pulsed output (e.g., at either a maximum or less than maximum power level, depending upon the EEPROM settings).

[0054] Still with reference to FIG. 2, forms of the generator 100 may enable communication with instrument-based data circuits. For example, the generator 100 may be configured to communicate with a first data circuit 136 and/or a second data circuit 138. For example, the first data circuit 136 may indicate a burn-in frequency slope, as described herein. Additionally or alternatively, any type of information may be communicated to second data circuit for storage therein via a data circuit interface (e.g., using a logic device). Such information may comprise, for example, an updated number of operations in which the instrument has been used and/or dates and/or times of its usage. In certain forms, the second data circuit may transmit data acquired by one or more sensors (e.g., an instrument-based temperature sensor). In certain forms, the second data circuit may receive data from the generator 100 and provide an indication to a user (e.g., an LED indication or other visible indication) based on the received data. The second data circuit 138 contained in the multifunction surgical instrument 108 of a surgical instrument. In some forms, the second data circuit 138 may be implemented in a many similar to that of the first data circuit 136 described herein. An instrument interface circuit may comprise a second data circuit interface to enable this communication. In one form, the second data circuit interface may comprise a tri-state digital interface, although other interfaces also may be used. In certain forms, the second data circuit may generally be any circuit for transmitting and/or receiving data. In one form, for example, the second data circuit may store

information pertaining to the particular surgical instrument with which it is associated. Such information may include, for example, a model number, a serial number, a number of operations in which the surgical instrument has been used, and/or any other type of information. In some forms, the second data circuit 138 may store information about the electrical and/or ultrasonic properties of an associated transducer 120, end effector 122, or ultrasonic drive system. Various processes and techniques described herein may be executed by a generator. It will be appreciated, however, that in certain example forms, all or a part of these processes and techniques may be performed by internal logic 139 of the multifunction surgical instrument 108.

[0055] FIG. 3 is a diagram of the surgical system 1000 of FIG. 1. In various forms, the generator 100 may comprise several separate functional elements, such as modules and/or blocks. Different functional elements or modules may be configured for driving the different kinds of surgical instruments 104, 106, 108. For example, an ultrasonic generator module 1008 may drive ultrasonic devices such as the ultrasonic device 104 via a cable 141. An electrosurgery/RF generator module 1010 may drive the electrosurgical device 106 via a cable 143. The respective modules 1008, 1009, 1010 may be combined as a combined RF generator/ultrasonic generator module 1009 to generate both respective drive signals for driving the combination RF electrosurgical/ultrasonic surgical instruments 108 via a cable 144. In various forms, the ultrasonic generator module 1008 and/or the electrosurgery/RF generator module 1010 each may be formed integrally with the generator 100. Alternatively, one or more of the modules 1008, 1009, 1010 may be provided as a separate circuit module electrically coupled to the generator 100. (The modules 1008, 1009, 1010 are shown in phantom to illustrate this option.) Also, in some forms, the electrosurgery/RF generator module 1010 may be formed integrally with the ultrasonic generator module 1008, or vice versa. Also, in some forms, the generator 100 may be omitted entirely and the modules 1008, 1009, 1010 may be executed by processors or other hardware within the respective instruments 104, 106, 108.

[0056] In other forms, the electrical outputs of the ultrasonic generator module 1008 and the electrosurgery/RF generator module 1010 may be combined into a single electrical signal capable of driving the multifunction device 108 simultaneously with electrosurgical RF and ultrasonic energies. The multifunction device 108 comprises an ultrasonic transducer 120 coupled to an ultrasonic blade and one or more electrodes in the end effector 122, 124 to receive electrosurgical RF energy. In such implementations, the combined RF/ultrasonic signal is coupled to the multifunction device 108. The multifunction device 108 comprises signal processing components to split the combined RF/ultrasonic signal such that the RF signal can

be delivered to the electrodes in the end effector 122 and the ultrasonic signal can be delivered to the ultrasonic transducer 120.

[0057] In accordance with the described forms, the ultrasonic generator module 1008 may produce a drive signal or signals of particular voltages, currents, and frequencies, e.g., 55,500 cycles per second (Hz). The drive signal or signals may be provided to the ultrasonic device 104, and specifically to the transducer 120, which may operate, for example, as described above. The transducer 120 and a waveguide extending through the shaft 129 (waveguide not shown in FIG. 2) may collectively form an ultrasonic drive system driving an ultrasonic blade 1017 of an end effector 125. In one form, the generator 100 may be configured to produce a drive signal of a particular voltage, current, and/or frequency output signal that can be stepped or otherwise modified with high resolution, accuracy, and repeatability.

[0058] The generator 100 may be activated to provide the drive signal to the transducer 120 in any suitable manner. For example, the generator 100 may comprise a foot switch 1020 coupled to the generator 100 via a footswitch cable 1022. A clinician may activate the transducer 120 by depressing the foot switch 1020. In addition, or instead of the foot switch 1020 some forms of the ultrasonic device 104 may utilize one or more switches positioned on the hand piece that, when activated, may cause the generator 100 to activate the transducer 120. In one form, for example, the one or more switches may comprise a pair of toggle buttons 137a, 137b (FIG. 2), for example, to determine an operating mode of the device 104. When the toggle button 137a is depressed, for example, the ultrasonic generator 100 may provide a maximum drive signal to the transducer 120, causing it to produce maximum ultrasonic energy output. Depressing toggle button 137b may cause the ultrasonic generator 100 to provide a user-selectable drive signal to the transducer 120, causing it to produce less than the maximum ultrasonic energy output. The device 108 additionally or alternatively may comprise a second switch (not shown) to, for example, indicate a position of a jaw closure trigger for operating jaws of the end effector 125. Also, in some forms, the ultrasonic generator 100 may be activated based on the position of the jaw closure trigger, (e.g., as the clinician depresses the jaw closure trigger to close the jaws, ultrasonic energy may be applied).

[0059] Additionally or alternatively, the one or more switches may comprise a toggle button 137c that, when depressed, causes the generator 100 to provide a pulsed output. The pulses may be provided at any suitable frequency and grouping, for example. In certain forms, the

power level of the pulses may be the power levels associated with toggle buttons 137a, 137b (maximum, less than maximum), for example.

[0060] It will be appreciated that a device 108 may comprise any combination of the toggle buttons 137a, 137b, 137c. For example, the device 108 could be configured to have only two toggle buttons: a toggle button 137a for producing maximum ultrasonic energy output and a toggle button 137c for producing a pulsed output at either the maximum or less than maximum power level. In this way, the drive signal output configuration of the generator 100 could be 5 continuous signals and 5 or 4 or 3 or 2 or 1 pulsed signals. In certain forms, the specific drive signal configuration may be controlled based upon, for example, EEPROM settings in the generator 100 and/or user power level selection(s).

[0061] In certain forms, a two-position switch may be provided as an alternative to a toggle button 137c. For example, a device 104 may include a toggle button 137a for producing a continuous output at a maximum power level and a two-position toggle button 137b. In a first detented position, toggle button 137b may produce a continuous output at a less than maximum power level, and in a second detented position the toggle button 137b may produce a pulsed output (e.g., at either a maximum or less than maximum power level, depending upon the EEPROM settings).

[0062] In accordance with the described forms, the electrosurgery/RF generator module 1010 may generate a drive signal or signals with output power sufficient to perform bipolar electrosurgery using radio frequency (RF) energy. In bipolar electrosurgery applications, the drive signal may be provided, for example, to electrodes of the electrosurgical device 106, for example. Accordingly, the generator 100 may be configured for therapeutic purposes by applying electrical energy to the tissue sufficient for treating the tissue (e.g., coagulation, cauterization, tissue welding).

[0063] The generator 100 may comprise an input device 112 (FIG. 1) located, for example, on a front panel of the generator 100 console. The input device 112 may comprise any suitable device that generates signals suitable for programming the operation of the generator 100. In operation, the user can program or otherwise control operation of the generator 100 using the input device 112. The input device 112 may comprise any suitable device that generates signals that can be used by the generator (e.g., by one or more processors contained in the generator) to control the operation of the generator 100 (e.g., operation of the ultrasonic generator module

1008, electrosurgery/RF generator module 1010, combined RF generator/ultrasonic generator 1009). In various forms, the input device 112 includes one or more of buttons, switches, thumbwheels, keyboard, keypad, touch screen monitor, pointing device, remote connection to a general purpose or dedicated computer. In other forms, the input device 112 may comprise a suitable user interface, such as one or more user interface screens displayed on a touch screen monitor, for example. Accordingly, by way of the input device 112, the user can set or program various operating parameters of the generator, such as, for example, current (I), voltage (V), frequency (f), and/or period (T) of a drive signal or signals generated by the ultrasonic generator module 1008 and/or electrosurgery/RF generator module 1010.

[0064] The generator 100 may also comprise an output device 110 (FIG. 1), such as an output indicator, located, for example, on a front panel of the generator 100 console. The output device 110 includes one or more devices for providing a sensory feedback to a user. Such devices may comprise, for example, visual feedback devices (e.g., a visual feedback device may comprise incandescent lamps, light emitting diodes (LEDs), graphical user interface, display, analog indicator, digital indicator, bar graph display, digital alphanumeric display, LCD display screen, LED indicators), audio feedback devices (e.g., an audio feedback device may comprise speaker, buzzer, audible, computer generated tone, computerized speech, voice user interface (VUI) to interact with computers through a voice/speech platform), or tactile feedback devices (e.g., a tactile feedback device comprises any type of vibratory feedback, haptic actuator).

[0065] Although certain modules and/or blocks of the generator 100 may be described by way of example, it can be appreciated that a greater or lesser number of modules and/or blocks may be used and still fall within the scope of the forms. Further, although various forms may be described in terms of modules and/or blocks to facilitate description, such modules and/or blocks may be implemented by one or more hardware components, e.g., processors, Digital Signal Processors (DSPs), Programmable Logic Devices (PLDs), Application Specific Integrated Circuits (ASICs), circuits, registers and/or software components, e.g., programs, subroutines, logic and/or combinations of hardware and software components. Also, in some forms, the various modules described herein may be implemented utilizing similar hardware positioned within the instruments 104, 106, 108 (i.e., the external generator 100 may be omitted).

[0066] In one form, the ultrasonic generator drive module 1008 and electrosurgery/RF drive module 1010 may comprise one or more embedded applications implemented as firmware,

software, hardware, or any combination thereof. The modules 1008, 1009, 1010 may comprise various executable modules such as software, programs, data, drivers, application program interfaces (APIs), and so forth. The firmware may be stored in nonvolatile memory (NVM), such as in bit masked read-only memory (ROM) or flash memory. In various implementations, storing the firmware in ROM may preserve flash memory. The NVM may comprise other types of memory including, for example, programmable ROM (PROM), erasable programmable ROM (EPROM), electrically erasable programmable ROM (EEPROM), or battery backed random-access memory (RAM) such as dynamic RAM (DRAM), Double-Data-Rate DRAM (DDRAM), and/or synchronous DRAM (SDRAM).

[0067] In one form, the modules 1008, 1009, 1010 comprise a hardware component implemented as a processor for executing program instructions for monitoring various measurable characteristics of the devices 104, 106, 108 and generating a corresponding output control signals for operating the devices 104, 106, 108. In forms in which the generator 100 is used in conjunction with the device 108, the output control signal may drive the ultrasonic transducer 120 in cutting and/or coagulation operating modes. Electrical characteristics of the device 108 and/or tissue may be measured and used to control operational aspects of the generator 100 and/or provided as feedback to the user. In forms in which the generator 100 is used in conjunction with the device 108, the output control signal may supply electrical energy (e.g., RF energy) to the end effector 125 in cutting, coagulation and/or desiccation modes. Electrical characteristics of the device 108 and/or tissue may be measured and used to control operational aspects of the generator 100 and/or provide feedback to the user. In various forms, as previously discussed, the hardware component may be implemented as a DSP, PLD, ASIC, circuits, and/or registers. In one form, the processor may be configured to store and execute computer software program instructions to generate the step function output signals for driving various components of the devices 104, 106, 108, such as the ultrasonic transducer 120 and the end effectors 122, 124, 125.

[0068] FIG. 4 illustrates an equivalent circuit 1050 of an ultrasonic transducer, such as the ultrasonic transducer 120, according to one form. The circuit 1050 comprises a first "motional" branch having a serially connected inductance L_s , resistance R_s and capacitance C_s that define the electromechanical properties of the resonator, and a second capacitive branch having a static capacitance C_o . Drive current I_g may be received from a generator at a drive voltage V_g , with motional current I_m flowing through the first branch and current $I_g - I_m$ flowing through the capacitive branch. Control of the electromechanical properties of the ultrasonic transducer may

be achieved by suitably controlling I_g and V_g . As explained above, conventional generator architectures may include a tuning inductor L_t (shown in phantom in FIG. 4) for tuning out in a parallel resonance circuit the static capacitance C_o at a resonant frequency so that substantially all of generator's current output I_g flows through the motional branch. In this way, control of the motional branch current I_m is achieved by controlling the generator current output I_g . The tuning inductor L_t is specific to the static capacitance C_o of an ultrasonic transducer, however, and a different ultrasonic transducer having a different static capacitance requires a different tuning inductor L_t . Moreover, because the tuning inductor L_t is matched to the nominal value of the static capacitance C_o at a single resonant frequency, accurate control of the motional branch current I_m is assured only at that frequency, and as frequency shifts down with transducer temperature, accurate control of the motional branch current is compromised.

[0069] Forms of the generator 100 do not rely on a tuning inductor L_t to monitor the motional branch current I_m . Instead, the generator 100 may use the measured value of the static capacitance C_o in between applications of power for a specific ultrasonic surgical instrument 104 (along with drive signal voltage and current feedback data) to determine values of the motional branch current I_m on a dynamic and ongoing basis (e.g., in real-time). Such forms of the generator 100 are therefore able to provide virtual tuning to simulate a system that is tuned or resonant with any value of static capacitance C_o at any frequency, and not just at single resonant frequency dictated by a nominal value of the static capacitance C_o .

[0070] FIG. 5 is a simplified block diagram of a generator 200, which is one form of the generator 100 (FIGS. 1-3). The generator is configured to provide inductorless tuning as described above, among other benefits. Additional details of the generator 200 are described in commonly assigned and contemporaneously filed U.S. Patent No. 9,060,775, titled SURGICAL GENERATOR FOR ULTRASONIC AND ELECTROSURGICAL DEVICES, the disclosure of which is incorporated herein by reference in its entirety. With reference to FIG. 5, the generator 200 may comprise a patient isolated stage 1052 in communication with a non-isolated stage 1054 via a power transformer 1056. A secondary winding 1058 of the power transformer 1056 is contained in the isolated stage 1052 and may comprise a tapped configuration (e.g., a center-tapped or a non-center-tapped configuration) to define drive signal outputs 1060a, 1060b, 1060c for outputting drive signals to different surgical instruments, such as, for example, an ultrasonic surgical instrument 104, electrosurgical device 106, and combination electrosurgical/ultrasonic device 108. In particular, drive signal outputs 1060a, 1060c may output an ultrasonic drive signal (e.g., a 420V RMS drive signal) to an ultrasonic surgical instrument 104, and drive signal

outputs 1060b, 1060c may output an electrosurgical drive signal (e.g., a 100V RMS drive signal) to an electrosurgical device 106, with output 1060b corresponding to the center tap of the power transformer 1056.

[0071] In certain forms, the ultrasonic and electrosurgical drive signals may be provided simultaneously to distinct surgical instruments and/or to a single surgical instrument having the capability to deliver both ultrasonic and electrosurgical energy to tissue, such as multifunction device 108 (FIGS. 1-3). It will be appreciated that the electrosurgical signal, provided either to a dedicated electrosurgical instrument and/or to a combined multifunction ultrasonic/electrosurgical instrument may be either a therapeutic or sub-therapeutic level signal. For example, the ultrasonic and radio frequency signals can be delivered separately or simultaneously from a generator with a single output port in order to provide the desired output signal to the surgical instrument, as will be discussed in more detail below. Accordingly, the generator can combine the ultrasonic and electrosurgical RF energies and deliver the combined energies to the multifunction ultrasonic/electrosurgical instrument. Bipolar electrodes can be placed on one or both jaws of the end effector. One jaw may be driven by ultrasonic energy in addition to electrosurgical RF energy, working simultaneously. The ultrasonic energy may be employed to dissect tissue while the electrosurgical RF energy may be employed for vessel sealing.

[0072] The non-isolated stage 1054 may comprise a power amplifier 1062 having an output connected to a primary winding 1064 of the power transformer 1056. In certain forms the power amplifier 1062 may be comprise a push-pull amplifier. For example, the non-isolated stage 1054 may further comprise a logic device 1066 for supplying a digital output to a digital-to-analog converter (DAC) 1068, which in turn supplies a corresponding analog signal to an input of the power amplifier 1062. In certain forms the logic device 1066 may comprise a programmable gate array (PGA), a field-programmable gate array (FPGA), programmable logic device (PLD), among other logic circuits, for example. The logic device 1066, by virtue of controlling the input of the power amplifier 1062 via the DAC 1068, may therefore control any of a number of parameters (e.g., frequency, waveform shape, waveform amplitude) of drive signals appearing at the drive signal outputs 1060a, 1060b, 1060c. In certain forms and as discussed below, the logic device 1066, in conjunction with a processor (e.g., a digital signal processor discussed below), may implement a number of digital signal processing (DSP)-based and/or other control algorithms to control parameters of the drive signals output by the generator 200.

[0073] Power may be supplied to a power rail of the power amplifier 1062 by a switch-mode regulator 1070. In certain forms the switch-mode regulator 1070 may comprise an adjustable buck regulator, for example. The non-isolated stage 1054 may further comprise a first processor 1074, which in one form may comprise a DSP processor such as an Analog Devices ADSP-21469 SHARC DSP, available from Analog Devices, Norwood, MA, for example, although in various forms any suitable processor may be employed. In certain forms the processor 1074 may control operation of the switch-mode power converter 1070 responsive to voltage feedback data received from the power amplifier 1062 by the DSP processor 1074 via an analog-to-digital converter (ADC) 1076. In one form, for example, the DSP processor 1074 may receive as input, via the ADC 1076, the waveform envelope of a signal (e.g., an RF signal) being amplified by the power amplifier 1062. The DSP processor 1074 may then control the switch-mode regulator 1070 (e.g., via a pulse-width modulated (PWM) output) such that the rail voltage supplied to the power amplifier 1062 tracks the waveform envelope of the amplified signal. By dynamically modulating the rail voltage of the power amplifier 1062 based on the waveform envelope, the efficiency of the power amplifier 1062 may be significantly improved relative to a fixed rail voltage amplifier schemes.

[0074] In certain forms, the logic device 1066, in conjunction with the DSP processor 1074, may implement a digital synthesis circuit such as a direct digital synthesizer (DDS) (see e.g., FIGS. 13, 14) control scheme to control the waveform shape, frequency and/or amplitude of drive signals output by the generator 200. In one form, for example, the logic device 1066 may implement a DDS control algorithm by recalling waveform samples stored in a dynamically-updated lookup table (LUT), such as a RAM LUT, which may be embedded in an FPGA. This control algorithm is particularly useful for ultrasonic applications in which an ultrasonic transducer, such as the ultrasonic transducer 120, may be driven by a clean sinusoidal current at its resonant frequency. Because other frequencies may excite parasitic resonances, minimizing or reducing the total distortion of the motional branch current may correspondingly minimize or reduce undesirable resonance effects. Because the waveform shape of a drive signal output by the generator 200 is impacted by various sources of distortion present in the output drive circuit (e.g., the power transformer 1056, the power amplifier 1062), voltage and current feedback data based on the drive signal may be input into an algorithm, such as an error control algorithm implemented by the DSP processor 1074, which compensates for distortion by suitably pre-distorting or modifying the waveform samples stored in the LUT on a dynamic, ongoing basis (e.g., in real-time). In one form, the amount or degree of pre-distortion applied to

the LUT samples may be based on the error between a computed motional branch current and a desired current waveform shape, with the error being determined on a sample-by-sample basis. In this way, the pre-distorted LUT samples, when processed through the drive circuit, may result in a motional branch drive signal having the desired waveform shape (*e.g.*, sinusoidal) for optimally driving the ultrasonic transducer. In such forms, the LUT waveform samples will therefore not represent the desired waveform shape of the drive signal, but rather the waveform shape that is required to ultimately produce the desired waveform shape of the motional branch drive signal when distortion effects are taken into account.

[0075] The non-isolated stage 1054 may further comprise an ADC 1078 and an ADC 1080 coupled to the output of the power transformer 1056 via respective isolation transformers 1082, 1084 for respectively sampling the voltage and current of drive signals output by the generator 200. In certain forms, the ADCs 1078, 1080 may be configured to sample at high speeds (*e.g.*, 80 MSPS) to enable oversampling of the drive signals. In one form, for example, the sampling speed of the ADCs 1078, 1080 may enable approximately 200x (depending on frequency) oversampling of the drive signals. In certain forms, the sampling operations of the ADC 1078, 1080 may be performed by a single ADC receiving input voltage and current signals via a two-way multiplexer. The use of high-speed sampling in forms of the generator 200 may enable, among other things, calculation of the complex current flowing through the motional branch (which may be used in certain forms to implement DDS-based waveform shape control described above), accurate digital filtering of the sampled signals, and calculation of real power consumption with a high degree of precision. Voltage and current feedback data output by the ADCs 1078, 1080 may be received and processed (*e.g.*, FIFO buffering, multiplexing) by the logic device 1066 and stored in data memory for subsequent retrieval by, for example, the DSP processor 1074. As noted above, voltage and current feedback data may be used as input to an algorithm for pre-distorting or modifying LUT waveform samples on a dynamic and ongoing basis. In certain forms, this may require each stored voltage and current feedback data pair to be indexed based on, or otherwise associated with, a corresponding LUT sample that was output by the logic device 1066 when the voltage and current feedback data pair was acquired. Synchronization of the LUT samples and the voltage and current feedback data in this manner contributes to the correct timing and stability of the pre-distortion algorithm.

[0076] In certain forms, the voltage and current feedback data may be used to control the frequency and/or amplitude (*e.g.*, current amplitude) of the drive signals. In one form, for example, voltage and current feedback data may be used to determine impedance phase. The

frequency of the drive signal may then be controlled to minimize or reduce the difference between the determined impedance phase and an impedance phase setpoint (e.g., 0°), thereby minimizing or reducing the effects of harmonic distortion and correspondingly enhancing impedance phase measurement accuracy. The determination of phase impedance and a frequency control signal may be implemented in the DSP processor 1074, for example, with the frequency control signal being supplied as input to a DDS control algorithm implemented by the logic device 1066.

[0077] In another form, for example, the current feedback data may be monitored in order to maintain the current amplitude of the drive signal at a current amplitude setpoint. The current amplitude setpoint may be specified directly or determined indirectly based on specified voltage amplitude and power setpoints. In certain forms, control of the current amplitude may be implemented by control algorithm, such as, for example, a PID control algorithm, in the processor 1074. Variables controlled by the control algorithm to suitably control the current amplitude of the drive signal may include, for example, the scaling of the LUT waveform samples stored in the logic device 1066 and/or the full-scale output voltage of the DAC 1068 (which supplies the input to the power amplifier 1062) via a DAC 1086.

[0078] The non-isolated stage 1054 may further comprise a second processor 1090 for providing, among other things user interface (UI) functionality. In one form, the UI processor 1090 may comprise an Atmel AT91SAM9263 processor having an ARM 926EJ-S core, available from Atmel Corporation, San Jose, CA, for example. Examples of UI functionality supported by the UI processor 1090 may include audible and visual user feedback, communication with peripheral devices (e.g., via a Universal Serial Bus (USB) interface), communication with the footswitch 1020, communication with an input device 112 (e.g., a touch screen display) and communication with an output device 110 (e.g., a speaker). The UI processor 1090 may communicate with the processor 1074 and the logic device 1066 (e.g., via serial peripheral interface (SPI) buses). Although the UI processor 1090 may primarily support UI functionality, it may also coordinate with the DSP processor 1074 to implement hazard mitigation in certain forms. For example, the UI processor 1090 may be programmed to monitor various aspects of user input and/or other inputs (e.g., touch screen inputs, footswitch 1020 inputs (FIG. 3), temperature sensor inputs) and may disable the drive output of the generator 200 when an erroneous condition is detected.

[0079] In certain forms, both the DSP processor 1074 and the UI processor 1090, for example, may determine and monitor the operating state of the generator 200. For the DSP processor 1074, the operating state of the generator 200 may dictate, for example, which control and/or diagnostic processes are implemented by the DSP processor 1074. For the UI processor 1090, the operating state of the generator 200 may dictate, for example, which elements of a user interface (e.g., display screens, sounds) are presented to a user. The respective DSP and UI processors 1074, 1090 may independently maintain the current operating state of the generator 200 and recognize and evaluate possible transitions out of the current operating state. The DSP processor 1074 may function as the master in this relationship and determine when transitions between operating states are to occur. The UI processor 1090 may be aware of valid transitions between operating states and may confirm if a particular transition is appropriate. For example, when the DSP processor 1074 instructs the UI processor 1090 to transition to a specific state, the UI processor 1090 may verify that requested transition is valid. In the event that a requested transition between states is determined to be invalid by the UI processor 1090, the UI processor 1090 may cause the generator 200 to enter a failure mode.

[0080] The non-isolated stage 1054 may further comprise a controller 1096 for monitoring input devices 112 (e.g., a capacitive touch sensor used for turning the generator 200 on and off, a capacitive touch screen). In certain forms, the controller 1096 may comprise at least one processor and/or other controller device in communication with the UI processor 1090. In one form, for example, the controller 1096 may comprise a processor (e.g., a Mega168 8-bit controller available from Atmel) configured to monitor user input provided via one or more capacitive touch sensors. In one form, the controller 1096 may comprise a touch screen controller (e.g., a QT5480 touch screen controller available from Atmel) to control and manage the acquisition of touch data from a capacitive touch screen.

[0081] In certain forms, when the generator 200 is in a "power off" state, the controller 1096 may continue to receive operating power (e.g., via a line from a power supply of the generator 200, such as the power supply 2011 discussed below). In this way, the controller 196 may continue to monitor an input device 112 (e.g., a capacitive touch sensor located on a front panel of the generator 200) for turning the generator 200 on and off. When the generator 200 is in the power off state, the controller 1096 may wake the power supply (e.g., enable operation of one or more DC/DC voltage converters 2013 of the power supply 2011) if activation of the "on/off" input device 112 by a user is detected. The controller 1096 may therefore initiate a sequence for transitioning the generator 200 to a "power on" state. Conversely, the controller 1096 may

initiate a sequence for transitioning the generator 200 to the power off state if activation of the "on/off" input device 112 is detected when the generator 200 is in the power on state. In certain forms, for example, the controller 1096 may report activation of the "on/off" input device 112 to the processor 1090, which in turn implements the necessary process sequence for transitioning the generator 200 to the power off state. In such forms, the controller 196 may have no independent ability for causing the removal of power from the generator 200 after its power on state has been established.

[0082] In certain forms, the controller 1096 may cause the generator 200 to provide audible or other sensory feedback for alerting the user that a power on or power off sequence has been initiated. Such an alert may be provided at the beginning of a power on or power off sequence and prior to the commencement of other processes associated with the sequence.

[0083] In certain forms, the isolated stage 1052 may comprise an instrument interface circuit 1098 to, for example, provide a communication interface between a control circuit of a surgical instrument (*e.g.*, a control circuit comprising hand piece switches) and components of the non-isolated stage 1054, such as, for example, the programmable logic device 1066, the DSP processor 1074 and/or the UI processor 1090. The instrument interface circuit 1098 may exchange information with components of the non-isolated stage 1054 via a communication link that maintains a suitable degree of electrical isolation between the stages 1052, 1054, such as, for example, an infrared (IR)-based communication link. Power may be supplied to the instrument interface circuit 1098 using, for example, a low-dropout voltage regulator powered by an isolation transformer driven from the non-isolated stage 1054.

[0084] In one form, the instrument interface circuit 1098 may comprise a logic device 2000 (*e.g.*, logic circuit, programmable logic circuit, PGA, FPGA, PLD) in communication with a signal conditioning circuit 2002. The signal conditioning circuit 2002 may be configured to receive a periodic signal from the logic circuit 2000 (*e.g.*, a 2 kHz square wave) to generate a bipolar interrogation signal having an identical frequency. The interrogation signal may be generated, for example, using a bipolar current source fed by a differential amplifier. The interrogation signal may be communicated to a surgical instrument control circuit (*e.g.*, by using a conductive pair in a cable that connects the generator 200 to the surgical instrument) and monitored to determine a state or configuration of the control circuit. The control circuit may comprise a number of switches, resistors and/or diodes to modify one or more characteristics (*e.g.*, amplitude, rectification) of the interrogation signal such that a state or configuration of the

control circuit is uniquely discernable based on the one or more characteristics. In one form, for example, the signal conditioning circuit 2002 may comprise an ADC for generating samples of a voltage signal appearing across inputs of the control circuit resulting from passage of interrogation signal therethrough. The logic device 2000 (or a component of the non-isolated stage 1054) may then determine the state or configuration of the control circuit based on the ADC samples.

[0085] In one form, the instrument interface circuit 1098 may comprise a first data circuit interface 2004 to enable information exchange between the logic circuit 2000 (or other element of the instrument interface circuit 1098) and a first data circuit disposed in or otherwise associated with a surgical instrument. In certain forms, for example, a first data circuit 2006 (FIG. 2) may be disposed in a cable integrally attached to a surgical instrument hand piece, or in an adaptor for interfacing a specific surgical instrument type or model with the generator 200. The data circuit 2006 may be implemented in any suitable manner and may communicate with the generator according to any suitable protocol including, for example, as described herein with respect to the data circuit 2006. In certain forms, the first data circuit may comprise a non-volatile storage device, such as an electrically erasable programmable read-only memory (EEPROM) device. In certain forms and referring again to FIG. 5, the first data circuit interface 2004 may be implemented separately from the logic device 2000 and comprise suitable circuitry (e.g., discrete logic devices, a processor) to enable communication between the programmable logic device 2000 and the first data circuit. In other forms, the first data circuit interface 2004 may be integral with the logic device 2000.

[0086] In certain forms, the first data circuit 2006 may store information pertaining to the particular surgical instrument with which it is associated. Such information may include, for example, a model number, a serial number, a number of operations in which the surgical instrument has been used, and/or any other type of information. This information may be read by the instrument interface circuit 1098 (e.g., by the logic device 2000), transferred to a component of the non-isolated stage 1054 (e.g., to logic device 1066, DSP processor 1074 and/or UI processor 1090) for presentation to a user via an output device 110 and/or for controlling a function or operation of the generator 200. Additionally, any type of information may be communicated to first data circuit 2006 for storage therein via the first data circuit interface 2004 (e.g., using the logic device 2000). Such information may comprise, for example, an updated number of operations in which the surgical instrument has been used and/or dates and/or times of its usage.

[0087] As discussed previously, a surgical instrument may be detachable from a hand piece (e.g., instrument 108 may be detachable from hand piece 109) to promote instrument interchangeability and/or disposability. In such cases, conventional generators may be limited in their ability to recognize particular instrument configurations being used and to optimize control and diagnostic processes accordingly. The addition of readable data circuits to surgical instrument instruments to address this issue is problematic from a compatibility standpoint, however. For example, designing a surgical instrument to remain backwardly compatible with generators that lack the requisite data reading functionality may be impractical due to, for example, differing signal schemes, design complexity, and cost. Forms of instruments discussed herein address these concerns by using data circuits that may be implemented in existing surgical instruments economically and with minimal design changes to preserve compatibility of the surgical instruments with current generator platforms.

[0088] Additionally, forms of the generator 200 may enable communication with instrument-based data circuits. For example, the generator 200 may be configured to communicate with a second data circuit 2007 contained in an instrument (e.g., instrument 108) of a surgical instrument (FIG. 2). In some forms, the second data circuit 2007 may be implemented in a many similar to that of the data circuit 6006 described herein. The instrument interface circuit 1098 may comprise a second data circuit interface 2010 to enable this communication. In one form, the second data circuit interface 2010 may comprise a tri-state digital interface, although other interfaces may also be used. In certain forms, the second data circuit may generally be any circuit for transmitting and/or receiving data. In one form, for example, the second data circuit may store information pertaining to the particular surgical instrument with which it is associated. Such information may include, for example, a model number, a serial number, a number of operations in which the surgical instrument has been used, and/or any other type of information.

[0089] In some forms, the second data circuit 2007 may store information about the electrical and/or ultrasonic properties of an associated transducer 120, end effector 125, or ultrasonic drive system. For example, the first data circuit 2006 may indicate a burn-in frequency slope, as described herein. Additionally or alternatively, any type of information may be communicated to second data circuit for storage therein via the second data circuit interface 2010 (e.g., using the logic device 2000). Such information may comprise, for example, an updated number of operations in which the instrument has been used and/or dates and/or times of its usage. In certain forms, the second data circuit may transmit data acquired by one or more sensors (e.g., an instrument-based temperature sensor). In certain forms, the second data circuit may receive

data from the generator 200 and provide an indication to a user (e.g., an LED indication or other visible indication) based on the received data.

[0090] In certain forms, the second data circuit and the second data circuit interface 2010 may be configured such that communication between the logic device 2000 and the second data circuit can be effected without the need to provide additional conductors for this purpose (e.g., dedicated conductors of a cable connecting a hand piece to the generator 200). In one form, for example, information may be communicated to and from the second data circuit using a 1-wire bus communication scheme implemented on existing cabling, such as one of the conductors used transmit interrogation signals from the signal conditioning circuit 2002 to a control circuit in a hand piece. In this way, design changes or modifications to the surgical instrument that might otherwise be necessary are minimized or reduced. Moreover, because different types of communications implemented over a common physical channel can be frequency-band separated, the presence of a second data circuit may be “invisible” to generators that do not have the requisite data reading functionality, thus enabling backward compatibility of the surgical instrument.

[0091] In certain forms, the isolated stage 1052 may comprise at least one blocking capacitor 2096-1 connected to the drive signal output 1060b to prevent passage of DC current to a patient. A single blocking capacitor may be required to comply with medical regulations or standards, for example. While failure in single-capacitor designs is relatively uncommon, such failure may nonetheless have negative consequences. In one form, a second blocking capacitor 2096-2 may be provided in series with the blocking capacitor 2096-1, with current leakage from a point between the blocking capacitors 2096-1, 2096-2 being monitored by, for example, an ADC 2098 for sampling a voltage induced by leakage current. The samples may be received by the logic circuit 2000, for example. Based changes in the leakage current (as indicated by the voltage samples in the form of FIG. 5), the generator 200 may determine when at least one of the blocking capacitors 2096-1, 2096-2 has failed. Accordingly, the form of FIG. 5 provides a benefit over single-capacitor designs having a single point of failure.

[0092] In certain forms, the non-isolated stage 1054 may comprise a power supply 2011 for outputting DC power at a suitable voltage and current. The power supply may comprise, for example, a 400 W power supply for outputting a 48 VDC system voltage. The power supply 2011 may further comprise one or more DC/DC voltage converters 2013 for receiving the output of the power supply to generate DC outputs at the voltages and currents required by the various

components of the generator 200. As discussed above in connection with the controller 1096, one or more of the DC/DC voltage converters 2013 may receive an input from the controller 1096 when activation of the "on/off" input device 112 by a user is detected by the controller 1096 to enable operation of, or wake, the DC/DC voltage converters 2013.

[0093] Having described operational details of various forms of the surgical system 1000 (FIG. 1) operations for the above surgical system 1000 may be further described generally in terms of a process for cutting and coagulating tissue employing a surgical instrument comprising an input device 112 and the generator 100. Although a particular process is described in connection with the operational details, it can be appreciated that the process merely provides an example of how the general functionality described herein can be implemented by the surgical system 10. Further, the given process does not necessarily have to be executed in the order presented herein unless otherwise indicated. As previously discussed, the input devices 112 may be employed to program the output (e.g., impedance, current, voltage, frequency) of the surgical instruments 104, 106, 108 (FIG. 1).

[0094] FIG. 6 illustrates one form of a drive system 32 of a generator 300, which is one form of the generator 100 (FIGS. 1-3). The generator 300 is configured to provide an ultrasonic electrical signal for driving an ultrasonic transducer (e.g., ultrasonic transducer 120 FIGS. 1-3), also referred to as a drive signal. The generator 300 is similar to and may be interchangeable with the generators 100, 200 (FIGS. 1-3 and 5). The drive system 32 is flexible and can create an ultrasonic electrical drive signal 416 at a desired frequency and power level setting for driving the ultrasonic transducer 50. In various forms, the generator 300 may comprise several separate functional elements, such as modules and/or blocks. Although certain modules and/or blocks may be described by way of example, it can be appreciated that a greater or lesser number of modules and/or blocks may be used and still fall within the scope of the forms. Further, although various forms may be described in terms of modules and/or blocks to facilitate description, such modules and/or blocks may be implemented by one or more hardware components, e.g., processors, Digital Signal Processors (DSPs), Programmable Logic Devices (PLDs), Application Specific Integrated Circuits (ASICs), circuits, registers and/or software components, e.g., programs, subroutines, logic and/or combinations of hardware and software components.

[0095] In one form, the generator 300 drive system 32 may comprise one or more embedded applications implemented as firmware, software, hardware, or any combination thereof. The

generator 300 drive system 32 may comprise various executable modules such as software, programs, data, drivers, application program interfaces (APIs), and so forth. The firmware may be stored in nonvolatile memory (NVM), such as in bit-masked read-only memory (ROM) or flash memory. In various implementations, storing the firmware in ROM may preserve flash memory. The NVM may comprise other types of memory including, for example, programmable ROM (PROM), erasable programmable ROM (EPROM), electrically erasable programmable ROM (EEPROM), or battery backed random-access memory (RAM) such as dynamic RAM (DRAM), Double-Data-Rate DRAM (DDRAM), and/or synchronous DRAM (SDRAM).

[0096] In one form, the generator 300 drive system 32 comprises a hardware component implemented as a processor 401 for executing program instructions for monitoring various measurable characteristics of the ultrasonic surgical instrument 104 (FIG. 1) and generating a step function output signal for driving the ultrasonic transducer in cutting and/or coagulation operating modes. It will be appreciated by those skilled in the art that the generator 300 and the drive system 32 may comprise additional or fewer components and only a simplified version of the generator 300 and the drive system 32 are described herein for conciseness and clarity. In various forms, as previously discussed, the hardware component may be implemented as a DSP, PLD, ASIC, circuits, and/or registers. In one form, the processor 401 may be configured to store and execute computer software program instructions to generate the step function output signals for driving various components of the ultrasonic surgical instrument 104, such as a transducer, an end effector, and/or a blade.

[0097] In one form, under control of one or more software program routines, the processor 401 executes the methods in accordance with the described forms to generate a step function formed by a stepwise waveform of drive signals comprising current (I), voltage (V), and/or frequency (f) for various time intervals or periods (T). The stepwise waveforms of the drive signals may be generated by forming a piecewise linear combination of constant functions over a plurality of time intervals created by stepping the generator 30 drive signals, e.g., output drive current (I), voltage (V), and/or frequency (f). The time intervals or periods (T) may be predetermined (e.g., fixed and/or programmed by the user) or may be variable. Variable time intervals may be defined by setting the drive signal to a first value and maintaining the drive signal at that value until a change is detected in a monitored characteristic. Examples of monitored characteristics may comprise, for example, transducer impedance, tissue impedance, tissue heating, tissue transection, tissue coagulation, and the like. The ultrasonic drive signals generated by the generator 300 include, without limitation, ultrasonic drive signals capable of

exciting the ultrasonic transducer 50 in various vibratory modes such as, for example, the primary longitudinal mode and harmonics thereof as well flexural and torsional vibratory modes.

[0098] In one form, the executable modules comprise one or more algorithm(s) 402 stored in memory that when executed causes the processor 401 to generate a step function formed by a stepwise waveform of drive signals comprising current (I), voltage (V), and/or frequency (f) for various time intervals or periods (T). The stepwise waveforms of the drive signals may be generated by forming a piecewise linear combination of constant functions over two or more time intervals created by stepping the output drive current (I), voltage (V), and/or frequency (f) of the generator 300. The drive signals may be generated either for predetermined fixed time intervals or periods (T) of time or variable time intervals or periods of time in accordance with the one or more algorithm(s) 402. Under control of the processor 401, the generator 100 steps (e.g., increment or decrement) the current (I), voltage (V), and/or frequency (f) up or down at a particular resolution for a predetermined period (T) or until a predetermined condition is detected, such as a change in a monitored characteristic (e.g., transducer impedance, tissue impedance). The steps can change in programmed increments or decrements. If other steps are desired, the generator 300 can increase or decrease the step adaptively based on measured system characteristics.

[0099] In operation, the user can program the operation of the generator 300 using the input device 406 located on the front panel of the generator 300 console. The input device 406 may comprise any suitable device that generates signals 408 that can be applied to the processor 401 to control the operation of the generator 300. In various forms, the input device 406 includes buttons, switches, thumbwheels, keyboard, keypad, touch screen monitor, pointing device, remote connection to a general purpose or dedicated computer. In other forms, the input device 406 may comprise a suitable user interface. Accordingly, by way of the input device 406, the user can set or program the current (I), voltage (V), frequency (f), and/or period (T) for programming the step function output of the generator 300. The processor 401 then displays the selected power level by sending a signal on line 410 to an output indicator 412.

[0100] In various forms, the output indicator 412 may provide visual, audible, and/or tactile feedback to the surgeon to indicate the status of a surgical procedure, such as, for example, when tissue cutting and coagulating is complete based on a measured characteristic of the ultrasonic surgical instrument 104, e.g., transducer impedance, tissue impedance, or other measurements as subsequently described. By way of example, and not limitation, visual

feedback comprises any type of visual indication device including incandescent lamps or light emitting diodes (LEDs), graphical user interface, display, analog indicator, digital indicator, bar graph display, digital alphanumeric display. By way of example, and not limitation, audible feedback comprises any type of buzzer, computer generated tone, computerized speech, voice user interface (VUI) to interact with computers through a voice/speech platform. By way of example, and not limitation, tactile feedback comprises any type of vibratory feedback provided through an instrument housing handle assembly.

[0101] In one form, the processor 401 may be configured or programmed to generate a digital current signal 414 and a digital frequency signal 418. These signals 414, 418 are applied to a digital synthesis circuit such as the direct digital synthesizer (DDS) circuit 420 (see e.g., FIGS. 13, 14) to adjust the amplitude and the frequency (f) of the current output signal 416 to the transducer. The output of the DDS circuit 420 is applied to an amplifier 422 whose output is applied to a transformer 424. The output of the transformer 424 is the signal 416 applied to the ultrasonic transducer, which is coupled to a blade by way of a waveguide. The output of the DDS circuit 420 may be stored in one more memory circuits including volatile (RAM) and non-volatile (ROM) memory circuits.

[0102] In one form, the generator 300 comprises one or more measurement modules or components that may be configured to monitor measurable characteristics of the ultrasonic instrument 104 (FIGS. 1-2) or the combination electrosurgical/ultrasonic instrument 108 (FIGS. 1-3). In the illustrated form, the processor 401 may be employed to monitor and calculate system characteristics. As shown, the processor 401 measures the impedance Z of the transducer by monitoring the current supplied to the transducer 50 and the voltage applied to the transducer. In one form, a current sense circuit 426 is employed to sense the current flowing through the transducer and a voltage sense circuit 428 is employed to sense the output voltage applied to the transducer 50. These signals may be applied to the analog-to-digital converter 432 (ADC) via an analog multiplexer 430 circuit or switching circuit arrangement. The analog multiplexer 430 routes the appropriate analog signal to the ADC 432 for conversion. In other forms, multiple ADCs 432 may be employed for each measured characteristic instead of the multiplexer 430 circuit. The processor 401 receives the digital output 433 of the ADC 432 and calculates the transducer impedance Z based on the measured values of current and voltage. The processor 401 adjusts the output drive signal 416 such that it can generate a desired power versus load curve. In accordance with programmed algorithms 402, the processor 401 can step

the drive signal 416, e.g., the current or frequency, in any suitable increment or decrement in response to the transducer impedance Z .

[0103] Having described operational details of various forms of the surgical system 1000, operations for the above surgical system 1000 may be further described in terms of a process for cutting and coagulating a blood vessel employing a surgical instrument comprising the input device 112 and the transducer impedance measurement capabilities described with reference to FIG. 6. Although a particular process is described in connection with the operational details, it can be appreciated that the process merely provides an example of how the general functionality described herein can be implemented by the surgical system 1000. Further, the given process does not necessarily have to be executed in the order presented herein unless otherwise indicated.

[0104] FIG. 7 illustrates one aspect of a drive system 320 of the generator 400, which is one form of the generator 100 (FIGS. 1-3). The generator 400 comprises a tissue impedance module 502. The drive system 320 is configured to generate the ultrasonic electrical drive signal 416 to drive the ultrasonic transducer 50. In one aspect, the tissue impedance module 502 may be configured to measure the impedance Z_t of tissue grasped between the blade 79 and the clamp arm assembly 451. The tissue impedance module 502 comprises an RF oscillator 506, a voltage sensing circuit 508, and a current sensing circuit 510. The voltage and current sensing circuits 508, 510 respond to the RF voltage V_{rf} applied to the blade 79 electrode and the RF current I_{rf} flowing through the blade 79 electrode, the tissue, and the conductive portion of the clamp arm assembly 451. The sensed voltage V_{rf} and current I_{rf} are converted to digital form by the ADC 432 via the analog multiplexer 430. The processor 401 receives the digitized output 433 of the ADC 432 and determines the tissue impedance Z_t by calculating the ratio of the RF voltage V_{rf} to current I_{rf} measured by the voltage sense circuit 508 and the current sense circuit 510. In one aspect, the transection of the inner muscle layer and the tissue may be detected by sensing the tissue impedance Z_t . Accordingly, detection of the tissue impedance Z_t may be integrated with an automated process for separating the inner muscle layer from the outer adventitia layer prior to transecting the tissue without causing a significant amount of heating, which normally occurs at resonance.

[0105] In one form, the RF voltage V_{rf} applied to the blade 79 electrode and the RF current I_{rf} flowing through the blade 79 electrode, the tissue, and the conductive portion of the clamp arm assembly 451 are suitable for vessel sealing and/or dissecting. Thus, the RF power output of

the generator 400 can be selected for non-therapeutic functions such as tissue impedance measurements as well as therapeutic functions such as vessel sealing and/or dissection. It will be appreciated, that in the context of the present disclosure, the ultrasonic and the RF electrosurgical energies can be supplied by the generator either individually or simultaneously.

[0106] In various forms, feedback is provided by the output indicator 412 shown in FIGS. 6 and 7. The output indicator 412 is particularly useful in applications where the tissue being manipulated by the end effector is out of the user's field of view and the user cannot see when a change of state occurs in the tissue. The output indicator 412 communicates to the user that a change in tissue state has occurred. As previously discussed, the output indicator 412 may be configured to provide various types of feedback to the user including, without limitation, visual, audible, and/or tactile feedback to indicate to the user (e.g., surgeon, clinician) that the tissue has undergone a change of state or condition of the tissue. By way of example, and not limitation, as previously discussed, visual feedback comprises any type of visual indication device including incandescent lamps or LEDs, graphical user interface, display, analog indicator, digital indicator, bar graph display, digital alphanumeric display. By way of example, and not limitation, audible feedback comprises any type of buzzer, computer generated tone, computerized speech, VUI to interact with computers through a voice/speech platform. By way of example, and not limitation, tactile feedback comprises any type of vibratory feedback provided through the instrument housing handle assembly. The change of state of the tissue may be determined based on transducer and tissue impedance measurements as previously described, or based on voltage, current, and frequency measurements.

[0107] In one form, the various executable modules (e.g., algorithms) comprising computer readable instructions can be executed by the processor 401 (FIGS. 6, 7) portion of the generator 300, 400 (FIGS. 6, 7). In various forms, the operations described with respect to the algorithms may be implemented as one or more software components, e.g., programs, subroutines, logic; one or more hardware components, e.g., processors, DSPs, PLDs, ASICs, circuits, registers; and/or combinations of software and hardware. In one form, the executable instructions to perform the algorithms may be stored in memory. When executed, the instructions cause the processor 401 to determine a change in tissue state provide feedback to the user by way of the output indicator 412. In accordance with such executable instructions, the processor 401 monitors and evaluates the voltage, current, and/or frequency signal samples available from the generator 400 and according to the evaluation of such signal samples determines whether a change in tissue state has occurred. As further described below, a

change in tissue state may be determined based on the type of ultrasonic instrument and the power level that the instrument is energized at. In response to the feedback, the operational mode of the ultrasonic surgical instrument 104 may be controlled by the user or may be automatically or semi-automatically controlled.

[0108] FIG. 8 illustrates an example of a generator 500, which is one form of the generator 100 (FIGS. 1-3). The generator 500 is configured to deliver multiple energy modalities to a surgical instrument. The generator 500 includes functionalities of the generators 200, 300, 400 shown in FIGS. 5-7. The generator 500 provides radio frequency and ultrasonic signals for delivering energy to a surgical instrument. The radio frequency and ultrasonic signals may be provided alone or in combination and may be provided simultaneously. As noted above, at least one generator output can deliver multiple energy modalities (e.g., ultrasonic, bipolar or monopolar RF, irreversible and/or reversible electroporation, and/or microwave energy, among others) through a single port and these signals can be delivered separately or simultaneously to the end effector to treat tissue. The generator 500 comprises a processor 502 coupled to a waveform generator 504. The processor 502 and waveform generator 504 are configured to generate a variety of signal waveforms based on information stored in a memory coupled to the processor 502, not shown for clarity of disclosure. The digital information associated with a waveform is provided to the waveform generator 504 which includes one or more digital-to-analog (DAC) converters to convert the digital input into an analog output. The analog output is fed to an amplifier 1106 for signal conditioning and amplification. The conditioned and amplified output of the amplifier 506 is coupled to a power transformer 508. The signals are coupled across the power transformer 508 to the secondary side, which is in the patient isolation side. A first signal of a first energy modality is provided to the surgical instrument between the terminals labeled ENERGY1 and RETURN. A second signal of a second energy modality is coupled across a capacitor 510 and is provided to the surgical instrument between the terminals labeled ENERGY2 and RETURN. It will be appreciated that more than two energy modalities may be output and thus the subscript "n" may be used to designate that up to n ENERGYn terminals may be provided, where n is a positive integer greater than 1. It also will be appreciated that up to "n" return paths RETURNn may be provided without departing from the scope of the present disclosure.

[0109] A first voltage sensing circuit 512 is coupled across the terminals labeled ENERGY1 and the RETURN path to measure the output voltage therebetween. A second voltage sensing circuit 524 is coupled across the terminals labeled ENERGY2 and the RETURN path to

measure the output voltage therebetween. A current sensing circuit 514 is disposed in series with the RETURN leg of the secondary side of the power transformer 508 as shown to measure the output current for either energy modality. If different return paths are provided for each energy modality, then a separate current sensing circuit should be provided in each return leg. The outputs of the first and second voltage sensing circuits 512, 524 are provided to respective isolation transformers 516, 522 and the output of the current sensing circuit 514 is provided to another isolation transformer 518. The outputs of the isolation transformers 516, 518, 522 in the on the primary side of the power transformer 508 (non-patient-isolated side) are provided to a one or more analog-to-digital converters 526 (ADC). The digitized output of the ADC 526 is provided to the processor 502 for further processing and computation. The output voltages and output current feedback information can be employed to adjust the output voltage and current provided to the surgical instrument and to compute output impedance, among other parameters. Input/output communications between the processor 502 and patient isolated circuits is provided through an interface circuit 520. Sensors also may be in electrical communication with the processor 502 by way of the interface 520.

[0110] In one aspect, the impedance may be determined by the processor 502 by dividing the output of either the first voltage sensing circuit 512 coupled across the terminals labeled ENERGY1/RETURN or the second voltage sensing circuit 524 coupled across the terminals labeled ENERGY2/RETURN by the output of the current sensing circuit 514 disposed in series with the RETURN leg of the secondary side of the power transformer 508. The outputs of the first and second voltage sensing circuits 512, 524 are provided to separate isolations transformers 516, 522 and the output of the current sensing circuit 514 is provided to another isolation transformer 516. The digitized voltage and current sensing measurements from the ADC 526 are provided the processor 502 for computing impedance. As an example, the first energy modality ENERGY1 may be ultrasonic energy and the second energy modality ENERGY2 may be RF energy. Nevertheless, in addition to ultrasonic and bipolar or monopolar RF energy modalities, other energy modalities include irreversible and/or reversible electroporation and/or microwave energy, among others. Also, although the example illustrated in FIG. 8 shows a single return path RETURN may be provided for two or more energy modalities, in other aspects multiple return paths RETURN_n may be provided for each energy modality ENERGY_n. Thus, as described herein, the ultrasonic transducer impedance may be measured by dividing the output of the first voltage sensing circuit 512 by the current sensing circuit 514 and the tissue impedance may be measured by dividing the output of the second

voltage sensing circuit 524 by the current sensing circuit 514.

[0111] As shown in FIG. 8, the generator 500 comprising at least one output port can include a power transformer 508 with a single output and with multiple taps to provide power in the form of one or more energy modalities, such as ultrasonic, bipolar or monopolar RF, irreversible and/or reversible electroporation, and/or microwave energy, among others, for example, to the end effector depending on the type of treatment of tissue being performed. For example, the generator 500 can deliver energy with higher voltage and lower current to drive an ultrasonic transducer, with lower voltage and higher current to drive RF electrodes for sealing tissue, or with a coagulation waveform for spot coagulation using either monopolar or bipolar RF electrosurgical electrodes. The output waveform from the generator 500 can be steered, switched, or filtered to provide the frequency to the end effector of the surgical instrument. The connection of an ultrasonic transducer to the generator 500 output would be preferably located between the output labeled ENERGY1 and RETURN as shown in FIG. 8. In one example, a connection of RF bipolar electrodes to the generator 500 output would be preferably located between the output labeled ENERGY2 and RETURN. In the case of monopolar output, the preferred connections would be active electrode (e.g., pencil or other probe) to the ENERGY2 output and a suitable return pad connected to the RETURN output.

[0112] In other aspects, the generators 100, 200, 300, 400, 500 described in connection with FIGS. 1-3 and 5-8, the ultrasonic generator drive circuit 114, and/or electrosurgery/RF drive circuit 116 as described in connection with FIG. 3 may be formed integrally with any one of the surgical instruments 104, 106, 108 described in connection with FIGS. 1 and 2. Accordingly, any of the processors, digital signal processors, circuits, controllers, logic devices, ADCs, DACs, amplifiers, converters, transformers, signal conditioners, data interface circuits, current and voltage sensing circuits, direct digital synthesis circuits, multiplexer (analog or digital), waveform generators, RF generators, memory, and the like, described in connection with any one of the generators 100, 200, 300, 400, 500 can be located within the surgical instruments 104, 106, 108 or may be located remotely from the surgical instruments 104, 106, 108 and coupled to the surgical instruments via wired and/or wireless electrical connections.

[0113] FIG. 9 shows a diagram of an electrosurgical system 9000 that allows for two ports on a generator 9001 and accounts for electrical isolation between two surgical instruments 9007, 9008. A scheme is provided for electrical isolation between the two instruments 9007, 9008 as they are located on the same patient isolation circuit. According to the configuration shown in

FIG. 9, unintended electrical power feedback is prevented through the electrosurgical system 9000. In various aspects, power FETs or relays are used to electrically isolate all power lines for each instrument 9007, 9008. According to one aspect, the power FETs or relays are controlled by a 1-wire communication protocol.

[0114] As shown in FIG. 9, a generator 9001, which is one form of the generator 100 (FIGS. 1-3), is coupled to a power switching mechanism 9003 and a communications system 9005. In one aspect, the power switching mechanism 9003 comprises power FETs, such as MOSFETs, and/or relays, such as electromechanical relays. In one aspect, the communications system 9005 comprises components for D1 emulation, FPGA expansion, and time slicing functionalities. The power switching mechanism 9003 is coupled to the communications system 9005. Each of the power switching mechanism 9003 and the communications system 9005 are coupled to surgical instruments 9007, 9009 (labeled device 1 and device 2). Each of surgical instruments 9007, 9009 comprise components for a combined RF and Ultrasonic energy input 9011, HSW 1-wire protocol interface 9013, HP 1-wire protocol interface 9015, and a presence resistor interface 9017. The power switching mechanism 9003 is coupled to the RF and Ultrasonic energy input 9011 for each of surgical instruments 9007, 9008. The communications system 9005 is coupled to the HSW 1-wire interface 9013, 9014, the HP 1-wire interface 9015, 9016, and presence interface 9017, 9018 for each of surgical instruments 9007, 9008. While two surgical instruments are shown in FIG. 9, there may be more than two devices according to various aspects.

[0115] FIGS. 10-12 illustrate aspects of an interface with a generator to support two instruments simultaneously that allows the instruments to quickly switch between active/inactive by a user in a sterile field. FIGS. 10-12 describe multiple communication schemes which would allow for a super cap / battery charger and dual surgical instruments. The aspects of FIGS. 10-12 allow for communications to two surgical instruments in the surgical field from a generator with at least one communications port and allow for an operator in sterile field to switch between devices, for example, without modifying the surgical instruments.

[0116] FIG. 10 is a diagram of a communications architecture of system 1001 comprising a generator 1003, which is one form of the generator 100 (FIGS. 1-3), and surgical instruments 9007, 9008, which are shown in FIG. 9. According to FIG. 10, the generator 9001 is configured for delivering multiple energy modalities to a plurality of surgical instruments. As discussed herein the various energy modalities include, without limitation, ultrasonic, bipolar or monopolar

RF, reversible and/or irreversible electroporation, and/or microwave energy modalities. The generator 9001 comprises a combined energy modality power output 1005, a communications interface 1007, and a presence interface 1049. According to the aspect of FIG. 10, the communications interface 1007 comprises an handswitch (HSW) serial interface 1011 and an handpiece (HP) serial interface 1013. The serial interfaces 1011, 1013 may comprise I²C, half duplex SPI, and/or Universal Asynchronous Receiver Transmitter (UART) components and/or functionalities. The generator 1003 provides the combined energy modalities power output 1005 to an adapter 1015, for example, a pass-through charger (PTC). The adapter 1015 comprises energy storage circuit 1071, control circuit 1019, a unique presence element 1021, and associated circuit discussed below. In one aspect, the presence element 1021 is a resistor. In another aspect, the presence element 1021 may be a bar code, Quick Response (QR) code, or similar code, or a value stored in memory such as, for example, a value stored in NVM. The presence element 1021 may be unique to the adapter 1015 so that, in the event that another adapter that did not use the same wire interfaces could not be used with the unique presence element 1021. In one aspect, the unique presence element 1021 is a resistor. The energy storage circuit 1071 comprises a switching mechanism 1023, energy storage device 1025, storage control 1027, storage monitoring component 1029, and a device power monitoring component 1031. The control circuit 1019 may comprise a processor, FPGA, PLD, CPLD, microcontroller, DSP, and/or ASIC, for example. According to the aspect shown in FIG. 10, an FPGA or microcontroller would act as an extension of an existing, similar computing hardware and allows for information to be relayed from on entity to another entity.

[0117] The switching mechanism 1023 is configured to receive the combined energy power output 1005 from the generator 1003 and it may be provided to the energy storage device 1025, surgical instrument 9007, and/or surgical instrument 9008. The device power monitoring component 1031 is coupled to the channels for the energy storage device 1025, surgical instrument 9007, surgical instrument 9008, and may monitor where power is flowing. The control circuit 1019 comprises communication interface 1033 coupled to the handswitch serial interface 1011 and an handpiece serial interface 1013 of the generator 1003. The control circuit 1019 is also coupled to the storage control 1027, storage monitoring component 1029, and device power monitoring component 1031 of the energy storage circuit 1071.

[0118] The control circuit 1019 further comprises a serial master interface 1035 that is coupled to handswitch (HSW) #1 circuit 1037 and handswitch (HSW) #2 circuit 1038, includes generation and ADC, a form of memory (non volatile or flash) 1039, along with a method for

detecting the presence of an attached instrument (Presence) #1 circuit 1041 and Presence #2 circuit 1042, which includes a voltage or current source and ADC. The serial master interface 1035 also includes handswitch NVM bypass channels, which couple the serial master interface 1035 to the outputs of the handswitch #1 circuit 1037 and the handswitch #2 circuit 1038, respectively. The handswitch #1 circuit 1037 and handswitch #2 circuit 1038 are coupled to the handswitch serial interfaces 9013, 9014 of the surgical instruments 9007, 9008, respectively. The serial master interface 1035 further includes handpiece serial channels that are coupled to the handpiece serial interfaces 9015, 9016 of the surgical instruments 9007, 9008, respectively. Further, Presence #1 and Presence #2 circuits 1041, 1042 are coupled to the presence interfaces 9017, 9018 of the surgical instruments 9007, 9008, respectively.

[0119] The system 1001 allows the control circuit 1019, such as an FPGA, to communicate with more surgical instruments using adapter 1015, which acts as an expansion adapter device. According to various aspects, the adapter 1015 expands the Input/Output (I/O) capability of the generator 1003 control. The adapter 1015 may function as an extension of the central processing unit that allows commands to be transmitted over a bus between the adapter 1015 and the generator 1003 and unpacks the commands and use them to bit-bang over interfaces or to control connected analog circuit. The adapter 1015 also allows for reading in ADC values from connected surgical instruments 9007, 9008 and relay this information to the generator control and the generator control would then control the two surgical instruments 9007, 9008. According to various aspects, the generator 1003 may control the surgical instruments 9007, 9008 as two separate state machines and may store the data.

[0120] Existing interfaces (the handswitch serial interface 1011 and the handpiece serial interface 1013 lines from generator 1003) may be used in a two-wire communication protocol that enables the generator 1003 control to communicate with multiple surgical instruments connected to a dual port interface, similar to the topology of a universal serial bus (USB) hub.

[0121] This allows interfacing with two separate surgical instruments simultaneously. The system 1001 may be able to generate and read hand switch waveforms and be able to handle incoming handpiece serial buses. It would also monitor two separate presence elements in the surgical instruments 9007, 9008. In one aspect, the system 1001 may include a unique presence element and may have its own NVM.

[0122] Further, according to various aspects, the control circuit 1019 may be controlled by the generator 1003. The communication between the adapter 1015 and connected surgical

instruments 9007, 9008 may be relayed to generator control. The generator 1003 would control the waveform generation circuit connected to the adapter 1015 to simultaneously generate handswitch signals for surgical instruments 9007, 9008.

[0123] The system 1001 may allow surgical instrument activity that can be simultaneously detected/monitored for two surgical instruments, even during activation. If upgradeable, the adapter 1015 would be capable of handling new surgical instrument communications protocols. Further, fast switching between surgical instruments may be accomplished.

[0124] FIG. 11 illustrates a communication architecture of system 1101 of a generator 1103, which is one form of the generator 100 (FIGS. 1-3), and surgical instruments 9007, 9008 shown in FIG. 9. According to FIG. 11, the generator 1103 is configured for delivering multiple energy modalities to a plurality of surgical instruments. As discussed herein the various energy modalities include, without limitation, ultrasonic, bipolar or monopolar RF, reversible and/or irreversible electroporation, and/or microwave energy modalities. As shown in FIG. 11, the generator 1103 comprises a combined energy modality power output 1105, an handswitch (HSW) serial interface 1111, a handpiece (HP) serial interface 1113, and a presence interface 1109. The generator 1103 provides the power output 1105 to an adapter 1115. According to the aspect shown in FIG. 11, communications between the adapter 1115 and the generator 1103 may be done solely through serial interfaces, such as the handswitch serial and handpiece serial interfaces 1111, 1113. The generator 1103 may use these handswitch and handpiece serial interfaces 1111, 1113 to control which instrument the generator 1103 is communicating with. Further, switching between instruments could occur between handswitch frames or at a much slower rate.

[0125] The adapter 1115 comprises energy storage circuit 1117, control circuit 1119, an adapter memory 1121 (e.g., a NVM such as an EEPROM), a serial programmable input/output (PIO) integrated circuit 1133, an handswitch Switching Mechanism 1135, an handpiece Switching Mechanism 1137, a Presence Switching Mechanism 1139, and a Generic Adapter 1141. In one aspect, the serial PIO integrated circuit 1133 may be an addressable switch. The energy storage circuitry 1117 comprises a switching mechanism 1123, energy storage device 1125, storage control component 1127, storage monitoring component 1129, and a device power monitoring component 1131. The control circuit 1119 may comprise a processor, FPGA, CPLD, PLD, microcontroller, DSP, and/or an ASIC, for example. According to the aspect of FIG. 11, an FPGA or microcontroller may have limited functionality and may solely comprise

functionality for monitoring and communicating energy storage.

[0126] The switching mechanism 1123 is configured to receive the combined energy power output 1105 from the generator 1103 and it may be provided to the energy storage device 1125, surgical instrument 9007, and/or surgical instrument 9008. The device power monitoring component 1131 is coupled to the channels for the energy storage device 1125, surgical instrument 9007, surgical instrument 9008, and may monitor where power is flowing.

[0127] The control circuit 1119 is coupled to the serial PIO integrated circuit 1133 and the serial PIO integrated circuit 1133 is coupled to the handpiece serial interface 1113 of the generator 1103. The control circuit 1119 may receive information regarding charger status flags and switching controls from the serial PIO integrated circuit 1133. Further, the control circuit 1119 is coupled to the handswitch switching mechanism 1135, the handpiece switching mechanism 1137, and the presence switching mechanism 1139. According to the aspect of FIG. 11, the control circuit 1119 may be coupled to the handswitch (HSW) switching mechanism 1135 and the handpiece switching mechanism 1137 for device selection and the control circuit 1119 may be coupled to the presence switching Mechanism 1139 for presence selection.

[0128] The handswitch switching mechanism 1135, the handpiece switching mechanism 1137, and the presence switching mechanism 1139 are coupled to the handswitch serial interface 1111, the handpiece serial interface 1113, and the presence interface 1109 of generator 1103, respectively. Further, the handswitch switching mechanism 1135, the handpiece switching mechanism 1137, and the presence switching mechanism 1139 are coupled to the handswitch serial interfaces 9013, 9014, the handpiece serial interfaces 9015, 9016, and the presence interfaces 9017, 9018 of the surgical instruments 9007, 9008, respectively. Further, the presence switching mechanism 1139 is coupled to the generic adapter 1141.

[0129] The generator 1103 switches between monitoring the surgical instruments 9007, 9008. According to various aspects, this switching may require the generator 1103 control to keep track of surgical instruments 9007, 9008 and run two separate state machines. The control circuit 1119 will need to remember which surgical instruments are connected, so that it can output an appropriate waveform to the ports where appropriate. The generator 1103 may generate/monitor hand switch signals, as well as communicating with serial NVM devices, such as adapter memory 1121. The generator 1103 may maintain constant communication with the activating surgical instrument for the duration of the activation.

[0130] System 1101 also allows for a generic adapter presence element. When first plugged in or powered on, the adapter 1115 would present this adapter resistance to the generator 1103. The generator 1103 may then relay commands to the adapter 1115 to switch between the different presence elements corresponding to the different surgical instruments 9007, 9008 connected to it. Accordingly, the generator 1103 is able to use its existing presence resistance circuit. The NVM memory 1121 exists on the adapter 1115 for additional identification of the adapter and to provide a level of security. In addition, the adapter 1115 has a serial I/O device, i.e. serial PIO integrated circuit 1133. The serial PIO integrated circuit 1133 provides a communication link between the generator 1103 and the adapter 1115.

[0131] It may be possible to communicate over the handpiece serial bus using serial communications to handpiece NVMs and UART style communication to the control circuit 1119. According to one aspect, if SLOW serial communication is used (i.e. not overdrive) and a high speed serial protocol is used, system 1101 may need to ensure that the communications protocol does not generate a signal that looked like a serial reset pulse. This would allow better generator 1103 to adapter 1115 communications and faster switching times between surgical instruments 9007, 9008.

[0132] The system 1101 uses generator communications protocol and analog circuit and allows the generator to accomplish decision making. It is a simple and efficient solution that uses a small number of circuit devices.

[0133] FIG. 12 illustrates a communications architecture of system 1201 of a generator 1203, which is one form of the generator 100 (FIGS. 1-3), and surgical instruments 9007, 9008 shown in FIG. 9. According to FIG. 12, the generator 1203 is configured for delivering multiple energy modalities to a plurality of surgical instruments. As discussed herein the various energy modalities include, without limitation, ultrasonic, bipolar or monopolar RF, reversible and/or irreversible electroporation, and/or microwave energy modalities. As shown in FIG. 12, the generator 1203 comprises a combined energy modality power output 1205, an handswitch serial interface 1211, an handpiece serial interface 1213, and a presence interface 1209. In one aspect, the handpiece serial interface 1213 allows for communication with the handpiece lines of the surgical instruments 9007, 9008 and also allows for control of the adapter 1215. The generator 1203 provides the combined energy modality power output 1205 to an adapter 1215. The adapter 1215 comprises energy storage circuit 1217, control circuit 1219, a serial PIO integrated circuit 1233, handswitch (HSW) #1 circuit 1231, handswitch (HSW) #2 circuit 1271,

handpiece switching mechanism 1221, presence switching mechanism 1239, switching mechanism 1235, instrument power monitoring 1237, and unique presence 1241. As shown in FIG. 12, the handswitch #1 circuit 1231 and the handswitch #2 circuit 1271 may comprise generation and ADC circuits. In one aspect, handswitch #1 circuit 1231 and/or handswitch #2 circuit 1271 comprise generation circuit with the ability to generate handswitch waveforms.

[0134] The control circuit 1219 is coupled to the handswitch serial interface 1211 of the generator 1203 while the serial PIO integrated circuit 1233 is coupled to the handpiece serial interface 1213 as is the handpiece switching mechanism 1221. Further, the control circuit 1119 is coupled to the handswitch #1 circuit 1231 and the handswitch #2 circuit 1271. The control circuit 1119 may comprise a processor, FPGA, CPLD, PLD, microcontroller, and/or ASIC, for example. In the example shown in FIG. 12, the control circuit 1219 modulates two devices into at least one digital waveform, which enable the generator 1203 to perform the button monitoring and decision making. The control circuit 1219 also may allow for communication to two independent surgical instruments could receive either waveform. The serial PIO integrated circuit 1233 is further coupled to the handpiece switching mechanism 1221, the instrument power monitoring 1237, and the presence switching mechanism 1239. The instrument power monitoring 1237 and the serial PIO integrated circuit 1233 may communicate results and failures to the generator 1203.

[0135] The switching mechanism 1223 is configured to receive the combined RF/Ultrasonic power output 1205 from the generator 1203 and it may be provided to the energy storage device 1225 or the switching mechanism 1235. The control circuit 1219 is also coupled to the storage control 1227 and storage monitoring 1229 of the energy storage circuit 1217. The switching mechanism 1235 may provide the power output received from the switching mechanism 1223 to surgical instrument 9007, and/or surgical instrument 9008. The instrument power monitoring 1237 is coupled to the channels for the power output to the surgical instrument 9007 and surgical instrument 9008. The instrument power monitoring 1237 also may ensure that the switching mechanism 1235 is outputting power to correct location.

[0136] The handswitch #1 circuit 1231 and the handswitch #2 block 1271 are coupled to the handswitch serial interfaces 9013, 9014 of the surgical instruments 9007, 9008, respectively. The handpiece switching mechanism 1221 is coupled to the handpiece serial interface 1213 of the generator 1203 and to the handpiece serial interfaces 9015, 9016 of the surgical instruments 9007, 9008, respectively. Further, the presence switching mechanism 1239 is

coupled to the presence interface 1209 of the generator 1203 and to the Presence Interfaces 9017, 9018 of the surgical instruments 9007, 9008, respectively. Further, Presence Switching mechanism is coupled to the unique presence 1241. In one aspect, different instrument presence elements may be switched on an on-demand basis using serial I/O or an adapter micro protocol.

[0137] A first communications protocol will be used to communicate to the control circuit 1219 on the adapter 1215. The generator 1205 also may have the ability to monitor surgical instruments 9007, 9008 at once. The adapter 1215 may comprise circuit to provide handswitch signal generation (e.g., in handswitch #1 circuit 1231 and handswitch #2 circuit 1271) along with ADCs to interpret this data. The adapter 1215 may modulate two surgical instrument signals into at least a first waveform and may have the ability to read in the first and second waveforms. In various aspects, the second waveforms may be interpreted and translated into the format of the first waveforms. Further, the first protocol has the ability to send 12 bits at 615 bits/sec.

[0138] The control circuit 1219 may take the handswitch data from surgical instruments 9007, 9008 and modulate it into a first protocol. There are a few ways of doing this, but it may mean that surgical instruments 9007, 9008 may comprise a first protocol functionality. The system 1201 could communicate 4-6 buttons from the surgical instrument 9007 and 4-6 buttons from the surgical instrument 9008 in the first protocol frame. Alternatively, the system 1201 could use some form of addressing to access the surgical instruments 9007, 9008. The control circuit 1219 may have the ability to address separate devices by having the generator 1203 send the control circuit 1219 different addresses split into two different address spaces, one for surgical instrument 9007 and one for surgical instrument 9008.

[0139] The handpiece communications may involve some form of switch that could either be controlled via a serial I/O device or through the control circuit 1219 via a first protocol style communication interface from the generator 1203. In one aspect, energy storage monitoring 1229 and switching between surgical instruments 9007, 9008 and charging states could be handled in this manner as well. Certain first protocol addresses could be assigned to the data from the energy storage circuit 1225 and to the surgical instruments 9007, 9008 themselves. Presence elements could also be switched in with this format. Further, in one aspect, the control circuit 1219 may translate frames into a separate format, which may mean that the control circuit 1219 might need to make some decisions on whether button presses on surgical instruments 9007, 9008 are valid or not. The system 1201 would, however, allow the generator

1203 to fully monitor the surgical instruments 9007, 9008 at the same time time-slicing or handling a new communications protocol on the handswitch serial interface 1211 of the generator 1203. The system 1201 uses generator communications to simultaneously detect the activity of two surgical instruments, even during activation.

[0140] According to some aspects of the present disclosure, various inputs maybe used to predict a user's intention in operating a surgical instrument, and RF and/or ultrasonic energy may be delivered according to the user's intention.

[0141] FIG. 13 shows a block diagram 1300 illustrating the selection of operations of a surgical instrument based on various inputs. The surgical instrument may comprise an RF energy output and an ultrasonic energy output. The surgical instrument may further comprise a first jaw and a second jaw configured for pivotal movement between a closed position and an open position.

[0142] A first input 1310 indicating a user selection of one of a first option and a second option may be received. For example, the first option may a seal only option, and the second option may be a seal and cut option. The user selection may be received as a button selection. For example, the button may be a switch or trigger located at a handle of the surgical instrument. Signal from a trigger aperture sensor may be fed via ASIC (application specific integration circuit) in the surgical instrument to a generator of RF and/or ultrasonic signals.

[0143] A second input 1320 indicating whether the first jaw and the second jaw are in the closed position or in the open position 1320 may be received. For example, a jaw aperture sensor in the surgical instrument may be used to sense the open or closed position, and a corresponding signal may be fed via ASIC in the surgical instrument to the generator of RF and/or ultrasonic signals.

[0144] A third input 1330 indicating electrical impedance at the RF energy output may be received. Low electrical impedance may indicate a short condition, which may be caused by a stapled tissue. Medium electrical impedance may indicate that a tissue is present without staples. High electrical impedance may indicate an open circuit condition.

[0145] Based at least in part on the first input 1310, the second input 1320 and the third input 1330, a mode of operation for treating a tissue may be selected 1340 from a plurality of modes of operation, which may comprise a first mode wherein the RF energy output applies RF energy to the tissue, and a second mode wherein the ultrasonic energy output applies ultrasonic energy

to the tissue. The plurality of modes of operation may further comprise a third mode wherein the RF energy output applies RF energy to the tissue and the ultrasonic energy output applies ultrasonic energy to the tissue; and a fourth mode wherein no RF energy or ultrasonic energy is applied to the tissue.

[0146] A level of energy applied by the RF energy output or ultrasonic energy output may also be selected 1350 based at least in part on the first input, the second input and the third input. For example, an EEPROM (Electrically Erasable Programmable Read-Only Memory) located at the surgical instrument or a non-volatile memory located at the generator may be accessed to load a wave-shape table and other RF and/or ultrasonic parameters such as voltage, current, power, and algorithm in order to performed the desired operation in the most optimal way.

[0147] According to some aspects of the present disclosure, the first input 1310, the second input 1320 and the third input 1330 may be received at a generator for providing RF energy and ultrasonic energy to the surgical instrument, and the selections are performed at the generator.

[0148] FIG. 14 shows a logic diagram 1400 illustrating specific operations of a surgical instrument selected based on various inputs. In particular, the logic diagram 1400 may be executed by multifunction surgical instrument 108 coupled to the generator 100 as shown in FIGS. 1 and 2 to complete a variety of user intentions 1490. As described herein, the system may be contained in the generator 100, the plug or adapter, and/or the surgical instrument 108 or device. The logic described by the logic diagram 1400 can be executed by any of the processing circuits described in connection with FIGS. 5-12 (e.g., processor, controller, digital signal processor, control circuit, and/or logic device collectively referred to as "system").

[0149] Accordingly, with reference now to FIGS. 1, 2, and 14, the surgical instrument 108 includes a mode selection button to select one of a seal only mode 1414 or a seal and cut mode 1418. When the user presses 1410 the mode selection button on the surgical instrument 108, the system determines whether the user intended to employ the seal only mode 1414 or the seal and cut mode 1418. The user election of the seal only mode 1414 will be described first.

[0150] Accordingly, upon selecting the seal only mode 1414, the system determines 1416 whether the clamp arm 146 of the surgical instrument 108 is in an open position or a closed position and then measures the impedance between the clamp arm 146 and the ultrasonic blade 149. When the clamp arm 146 is in a closed position 1422 the measured electrical impedance 1424 between the electrode in the clamp arm 146 and the ultrasonic blade 149 is

low 1438 or indicates a short circuit, the system assumes that stapled tissue is present between the jaws 125 and applies 1440 low ultrasonic energy to the tissue located between the clamp arm 146 and the ultrasonic blade 149. Accordingly, the surgical instrument 108 completes the user intention of sealing 1442 stapled tissue located between the clamp arm 146 and the ultrasonic blade 149.

[0151] Still with reference to the seal only mode 1414 sequence, when the he clamp arm 146 is in a closed position 1422 and the measured electrical impedance 1424 is within a range that indicates 1444 the presence of tissue without staples between the clamp arm 146 and the ultrasonic blade 149, the system applies 1446 RF energy according to a predetermined seal only algorithm. Accordingly, the surgical instrument 108 completes the user intention 1448 of sealing a vessel or tissue bundle located between the clamp arm 146 and the ultrasonic blade 149.

[0152] Still with reference to the seal only mode 1414, when the seal only mode 1414 is selected and the clamp arm 146 is in an open 1426 position, and the measured electrical impedance 1428 is high 1450 or indicates an open circuit, the system determines that an error has occurred and provides 1454 an error indication but does not deliver either RF or ultrasonic energy. Accordingly, the surgical instrument 108 completes the user intention 1454 of no job identified.

[0153] Still with reference to the seal only mode 1414 sequence, when the clamp arm 146 is in an open position 1426 and the electrical impedance 1428 is medium 1456 or indicates the presence of tissue located between the clamp arm 146 and the ultrasonic blade 149, the system determines that the user intends to perform spot coagulation and applies 1458 high voltage RF energy to the tissue. Accordingly, the surgical instrument 108 completes the user intention 1460 of spot coagulating the tissue. The RF energy provided for spot coagulation also may have a high crest factor as shown and described in connection with FIG. 21.

[0154] Having described the seal only mode 1414 sequence, the description now turns to the seal and cut mode 1418 sequence. When the seal and cut mode 1418 option is selected, the system determines 1420 whether the clamp arm 146 is in an open position or a closed position. When the clamp arm 146 is in a closed position 1430 and the measured electrical impedance 1432 is low 1462 or indicates the presence of a short circuit, the system determines that stapled tissue is located between the clamp arm 146 and the ultrasonic blade 149 and applies

1464 low ultrasonic energy to the stapled tissue. Accordingly, the surgical instrument 108 completes the user intention 1466 of sealing and cutting stapled tissue located between the clamp arm 146 and the ultrasonic blade 149.

[0155] Still with reference to the seal and cut mode 1418, when the clamp arm 146 is in a closed 1430 and the measured electrical impedance 1432 is medium 1468 or indicates that tissue without staples is present between the clamp arm 146 and the ultrasonic blade 149, the system firstly applies 1470 RF energy to seal the tissue and secondly applies 1470 ultrasonic energy to cut the tissue. Accordingly, the surgical instrument 108 completes the user intention 1472 of sealing and cutting a vessel or tissue bundle located between the clamp arm 146 and the ultrasonic blade 149.

[0156] Still with reference to the seal and cut mode 1418, when the clamp arm 146 is in an open position 1434 and the measured electrical impedance 1436 is high 1474 or indicates an open circuit, the system applies 1476 high ultrasonic energy to the tissue. Accordingly, the surgical instrument 108 completes the user intention 1478 of back cutting or creating anotomy.

[0157] Still with reference to the seal and cut mode 1418, when the clamp arm 146 is in an open position 1434 and the measured electrical impedance 1436 is medium 1480 or indicates that tissue is present between the clamp arm 146 and the ultrasonic blade 149, the system determines that the user intends to perform spot coagulation and applies 1482 high voltage RF to the to the tissue. Accordingly, the surgical instrument 108 completes the user intention 1484 of spot coagulation. The RF energy provided for spot coagulation may have a high crest factor as shown and described in connection with FIG. 21.

[0158] Therefore, according to aspects of the present disclosure, various tissue effects can be provided in an automatic fashion. Therefore, a user does not need to access a complicated set of buttons or other inputs to perform the desired operation.

[0159] FIGS. 15 and 16 provide illustration of system configuration for an example circuit topology shown and described with regard to FIGS. 13-14. The system configuration comprises a plurality sections, where the plurality of sections include a generator (labeled GENERATOR), a proximal plug (labeled PLUG 1), a cable, a distal plug (labeled PLUG 2), a handle of a surgical instrument, and an application portion (labeled APP) of a surgical instrument. According to various aspects, the proximal plug may be a component of the generator, it may be a

component of cable, or it may be separate component. Similarly, the distal plug may be a component of the cable, it may be a component of handle, or it may be separate component.

[0160] FIG. 15 provides an illustration of a system 6600 configuration for an example circuit topology shown and described with regard to FIGS. 13-14, including MOSFET switches and a control circuit in the handle, configured to manage RF and ultrasonic currents output by a generator according to one aspect of the present disclosure. The system 6600 includes electro-mechanical or solid state switches such as MOSFET switches and a control circuit in the handle. The generator comprises interfaces for an ultrasonic signal 6601, an interface for an RF signal 6603, a primary return terminal interface 6605, an HSW interface 6607, a secondary return terminal interface 6609, an identification interface 6611, and a presence interface 6613. The proximal plug comprises matching interfaces to those of generator, an EEPROM 6617, and presence resistor 6619. The proximal plug outputs are carried through the cable and the distal plug to the handle without any component circuitry in either the cable or the distal plug. The handle comprises the MOSFET switches 6615 that are each coupled to rectifier circuits 6621, which are each coupled to a pair of coupling inductors 6623, also in the handle. The rectifier circuits 6621 each comprise at least one diode and at least one capacitor. The control circuit 6627 (e.g., ASIC) is coupled to a driver circuit 6625 that feeds the coupling inductors 6623 and the rectifier circuits 6621 to control the state of the MOSFET switches 6615. The driver circuit 6625 and control circuit 6627 are located in the handle. The handle further comprises resonator 6629, diode and capacitor circuits 6631, EEPROM 6635, and switch array 6637. The switch array 6637 may comprise electro-mechanical devices, transistor devices, and the like. The transistor devices may include bipolar junction transistors (BJT), FETs, MOSFETs, or a combination thereof. The rectifier portion of the diode and capacitor circuit 6631 is coupled to the HSW interface 6607 and the secondary return terminal interface 6609 of the generator and feed into control circuit 6627.

[0161] The application portion comprises EEPROM 6639, presence resistor 6641, and outputs for RF and ultrasonic energy 6643, 6645, respectively. EEPROM 6639 and presence resistor 6641 are coupled to control circuit 6627. The system 6600 allows switching between an RF mode and an ultrasonic mode and allows for a low cost cable configuration.

[0162] FIG. 16 provides an illustration of a system 6900 configuration for an example circuit topology shown and described with regard to FIGS. 13-14, including bandstop filters and a control circuit in the handle, configured to manage RF and ultrasonic currents output by a

generator according to one aspect of the present disclosure. The system 6900 includes bandstop filters and a control circuit in the handle. The generator comprises interfaces for an ultrasonic signal 6901, an interface for an RF signal 6903, a primary return terminal interface 6905, an HSW interface 6907, a secondary return terminal interface 6909, an identification interface 6911, and a presence interface 6913. The proximal plug comprises matching interfaces to those of generator, an EEPROM 6917, and presence resistor 6919. The proximal plug outputs are carried through the cable and distal plug without any component circuitry in either the cable or the distal plug. The handle comprises a pair of bandstop filters 6915, rectifier circuit 6931, EEPROM 6935, control circuit 6927, switch array 6937, and resonator 6929. Rectifier circuit 6931 comprises at least one diode and at least one capacitor. Control circuit 6927 is coupled to EEPROM 6935, switch array 6937, and rectifier circuit 6931. The switch array 6937 may comprise electro-mechanical devices, transistor devices, and the like. The transistor devices may include bipolar junction transistors (BJT), FETs, MOSFETs, or a combination thereof.

[0163] The application portion comprises EEPROM 6939, presence resistor 6941, and outputs for RF and ultrasonic energy 6943, 6945, respectively. The pair of bandstop filters 6915 are coupled to the outputs for RF and ultrasonic energy 6943, 6945. EEPROM 6939 and presence resistor 6941 are coupled to control circuit 6927. The system 6900 allows switching between an RF mode and an ultrasonic mode and supports mixed output frequencies, which allows tissues impedance sensing while the ultrasonic output is active. It also provides for a low cost cable configuration.

[0164] Examples of waveforms representing energy for delivery from a generator are illustrated in FIGS. 17-21. FIG. 17 illustrates an example graph 600 showing first and second individual waveforms representing an RF output signal 602 and an ultrasonic output signal 604 superimposed on the same time and voltage scale for comparison purposes. These output signals 602, 604 are provided at the ENERGY output of the generator 100. Time (t) is shown along the horizontal axis and voltage (V) is shown along the vertical axis. The RF output signal 602 has a frequency of about 330kHz RF and a peak-to-peak voltage of $\pm 1V$. The ultrasonic output signal 604 has a frequency of about 55kHz and a peak-to-peak voltage of $\pm 1V$. It will be appreciated that the time (t) scale along the horizontal axis and the voltage (V) scale along the vertical axis are normalized for comparison purposes and may be different actual implementations, or represent other electrical parameters such as current.

[0165] FIG. 18 illustrates an example graph 610 showing the sum of the two output signals 602, 604 shown in FIG. 17. Time (t) is shown along the horizontal axis and voltage (V) is shown along the vertical axis. The sum of the RF output signal 602 and the ultrasonic output signal 604 shown in FIG. 17 produces a combined output signal 612 having a 2V peak-to-peak voltage, which is twice the amplitude of the original RF and ultrasonic signals shown (1V peak-to-peak) shown in FIG. 17. An amplitude of twice the original amplitude can cause problems with the output section of the generator, such as distortion, saturation, clipping of the output, or stresses on the output components. Thus, the management of a single combined output signal 612 that has multiple treatment components is an important aspect of the generator 500 shown in FIG. 8. There are a variety of ways to achieve this management. In one form, one of the two RF or ultrasonic output signals 602, 604 can be dependent on the peaks of the other output signal. In one aspect, the RF output signal 602 may depend on the peaks of the ultrasonic signal 604, such that the output is reduced when a peak is anticipated. Such a function and resulting waveform is shown in FIG. 19.

[0166] For example, FIG. 19 illustrates an example graph 620 showing a combined output signal 622 representative of a dependent sum of the output signals 602, 604 shown in FIG. 17. Time (t) is shown along the horizontal axis and voltage (V) is shown along the vertical axis. As shown in FIG. 17, the RF output signal 602 component of FIG. 17 depends on the peaks of the ultrasonic output signal 604 component of FIG. 17 such that the amplitude of the RF output signal component of the dependent sum combined output signal 622 is reduced when an ultrasonic peak is anticipated. As shown in the example graph 620 in FIG. 17, the peaks have been reduced from 2 to 1.5. In another form, one of the output signals is a function of the other output signal.

[0167] For example, FIG. 20 illustrates an example graph of an analog waveform 630 showing an output signal 632 representative of a dependent sum of the output signals 602, 604 shown in FIG. 17. Time (t) is shown along the horizontal axis and voltage (V) is shown along the vertical axis. As shown in FIG. 20, the RF output signal 602 is a function of the ultrasonic output signal 604. This provides a hard limit on the amplitude of the output. As shown in FIG. 20, the ultrasonic output signal 604 is extractable as a sine wave while the RF output signal 602 has distortion but not in a way to affect the coagulation performance of the RF output signal 602.

[0168] A variety of other techniques can be used for compressing and/or limiting the waveforms of the output signals. It should be noted that the integrity of the ultrasonic output signal 604

(FIG. 17) can be more important than the integrity of the RF output signal 602 (FIG. 17) as long as the RF output signal 602 has low frequency components for safe patient levels so as to avoid neuro-muscular stimulation. In another form, the frequency of an RF waveform can be changed on a continuous basis in order to manage the peaks of the waveform. Waveform control is important as more complex RF waveforms, such as a coagulation-type waveform 642, as illustrated in the graph 640 shown in FIG. 21, are implemented with the system. Again, time (t) is shown along the horizontal axis and voltage (V) is shown along the vertical axis. The coagulation-type waveform 642 illustrated in FIG. 21 has a crest factor of 5.8, for example.

[0169] While various details have been set forth in the foregoing description, it will be appreciated that the various aspects of the serial communication protocol for medical device may be practiced without these specific details. For example, for conciseness and clarity selected aspects have been shown in block diagram form rather than in detail. Some portions of the detailed descriptions provided herein may be presented in terms of instructions that operate on data that is stored in a computer memory. Such descriptions and representations are used by those skilled in the art to describe and convey the substance of their work to others skilled in the art. In general, an algorithm refers to a self-consistent sequence of steps leading to a desired result, where a "step" refers to a manipulation of physical quantities which may, though need not necessarily, take the form of electrical or magnetic signals capable of being stored, transferred, combined, compared, and otherwise manipulated. It is common usage to refer to these signals as bits, values, elements, symbols, characters, terms, numbers, or the like. These and similar terms may be associated with the appropriate physical quantities and are merely convenient labels applied to these quantities.

[0170] Unless specifically stated otherwise as apparent from the foregoing discussion, it is appreciated that, throughout the foregoing description, discussions using terms such as "processing" or "computing" or "calculating" or "determining" or "displaying" or the like, refer to the action and processes of a computer system, or similar electronic computing device, that manipulates and transforms data represented as physical (electronic) quantities within the computer system's registers and memories into other data similarly represented as physical quantities within the computer system memories or registers or other such information storage, transmission or display devices.

[0171] It is worthy to note that any reference to "one aspect," "an aspect," "one form," or "an form" means that a particular feature, structure, or characteristic described in connection with

the aspect is included in at least one aspect. Thus, appearances of the phrases “in one aspect,” “in an aspect,” “in one form,” or “in an form” in various places throughout the specification are not necessarily all referring to the same aspect. Furthermore, the particular features, structures or characteristics may be combined in any suitable manner in one or more aspects.

[0172] Some aspects may be described using the expression “coupled” and “connected” along with their derivatives. It should be understood that these terms are not intended as synonyms for each other. For example, some aspects may be described using the term “connected” to indicate that two or more elements are in direct physical or electrical contact with each other. In another example, some aspects may be described using the term “coupled” to indicate that two or more elements are in direct physical or electrical contact. The term “coupled,” however, also may mean that two or more elements are not in direct contact with each other, but yet still cooperate or interact with each other.

[0173] It is worthy to note that any reference to “one aspect,” “an aspect,” “one form,” or “an form” means that a particular feature, structure, or characteristic described in connection with the aspect is included in at least one aspect. Thus, appearances of the phrases “in one aspect,” “in an aspect,” “in one form,” or “in an form” in various places throughout the specification are not necessarily all referring to the same aspect. Furthermore, the particular features, structures or characteristics may be combined in any suitable manner in one or more aspects.

[0174] Although various forms have been described herein, many modifications, variations, substitutions, changes, and equivalents to those forms may be implemented and will occur to those skilled in the art. Also, where materials are disclosed for certain components, other materials may be used. It is therefore to be understood that the foregoing description and the appended claims are intended to cover all such modifications and variations as falling within the scope of the disclosed forms. The following claims are intended to cover all such modification and variations.

[0175] In a general sense, those skilled in the art will recognize that the various aspects described herein which can be implemented, individually and/or collectively, by a wide range of hardware, software, firmware, or any combination thereof can be viewed as being composed of various types of “electrical circuitry.” Consequently, as used herein “electrical circuitry” includes, but is not limited to, electrical circuitry having at least one discrete electrical circuit, electrical circuitry having at least one integrated circuit, electrical circuitry having at least one application

specific integrated circuit, electrical circuitry forming a general purpose computing device configured by a computer program (e.g., a general purpose computer configured by a computer program which at least partially carries out processes and/or devices described herein, or a microprocessor configured by a computer program which at least partially carries out processes and/or devices described herein), electrical circuitry forming a memory device (e.g., forms of random access memory), and/or electrical circuitry forming a communications device (e.g., a modem, communications switch, or optical-electrical equipment). Those having skill in the art will recognize that the subject matter described herein may be implemented in an analog or digital fashion or some combination thereof.

[0176] The foregoing detailed description has set forth various forms of the devices and/or processes via the use of block diagrams, flowcharts, and/or examples. Insofar as such block diagrams, flowcharts, and/or examples contain one or more functions and/or operations, it will be understood by those within the art that each function and/or operation within such block diagrams, flowcharts, or examples can be implemented, individually and/or collectively, by a wide range of hardware, software, firmware, or virtually any combination thereof. In one form, several portions of the subject matter described herein may be implemented via Application Specific Integrated Circuits (ASICs), Field Programmable Gate Arrays (FPGAs), digital signal processors (DSPs), or other integrated formats. However, those skilled in the art will recognize that some aspects of the forms disclosed herein, in whole or in part, can be equivalently implemented in integrated circuits, as one or more computer programs running on one or more computers (e.g., as one or more programs running on one or more computer systems), as one or more programs running on one or more processors (e.g., as one or more programs running on one or more microprocessors), as firmware, or as virtually any combination thereof, and that designing the circuitry and/or writing the code for the software and or firmware would be well within the skill of one of skill in the art in light of this disclosure. In addition, those skilled in the art will appreciate that the mechanisms of the subject matter described herein are capable of being distributed as a program product in a variety of forms, and that an illustrative form of the subject matter described herein applies regardless of the particular type of signal bearing medium used to actually carry out the distribution. Examples of a signal bearing medium include, but are not limited to, the following: a recordable type medium such as a floppy disk, a hard disk drive, a Compact Disc (CD), a Digital Video Disk (DVD), a digital tape, a computer memory, etc.; and a transmission type medium such as a digital and/or an analog communication medium (e.g., a fiber optic cable, a waveguide, a wired communications link, a

wireless communication link (e.g., transmitter, receiver, transmission logic, reception logic, etc.), etc.).

[0177] All of the above-mentioned U.S. patents, U.S. patent application publications, U.S. patent applications, foreign patents, foreign patent applications, non-patent publications referred to in this specification and/or listed in any Application Data Sheet, or any other disclosure material are incorporated herein by reference, to the extent not inconsistent herewith. As such, and to the extent necessary, the disclosure as explicitly set forth herein supersedes any conflicting material incorporated herein by reference. Any material, or portion thereof, that is said to be incorporated by reference herein, but which conflicts with existing definitions, statements, or other disclosure material set forth herein will only be incorporated to the extent that no conflict arises between that incorporated material and the existing disclosure material.

[0178] One skilled in the art will recognize that the herein described components (e.g., operations), devices, objects, and the discussion accompanying them are used as examples for the sake of conceptual clarity and that various configuration modifications are contemplated. Consequently, as used herein, the specific exemplars set forth and the accompanying discussion are intended to be representative of their more general classes. In general, use of any specific exemplar is intended to be representative of its class, and the non-inclusion of specific components (e.g., operations), devices, and objects should not be taken limiting.

[0179] With respect to the use of substantially any plural and/or singular terms herein, those having skill in the art can translate from the plural to the singular and/or from the singular to the plural as is appropriate to the context and/or application. The various singular/plural permutations are not expressly set forth herein for sake of clarity.

[0180] The herein described subject matter sometimes illustrates different components contained within, or connected with, different other components. It is to be understood that such depicted architectures are merely example, and that in fact many other architectures may be implemented which achieve the same functionality. In a conceptual sense, any arrangement of components to achieve the same functionality is effectively “associated” such that the desired functionality is achieved. Hence, any two components herein combined to achieve a particular functionality can be seen as “associated with” each other such that the desired functionality is achieved, irrespective of architectures or intermedial components. Likewise, any two components so associated can also be viewed as being “operably connected,” or “operably

coupled,” to each other to achieve the desired functionality, and any two components capable of being so associated can also be viewed as being “operably couplable,” to each other to achieve the desired functionality. Specific examples of operably couplable include but are not limited to physically mateable and/or physically interacting components, and/or wirelessly interactable, and/or wirelessly interacting components, and/or logically interacting, and/or logically interactable components.

[0181] In some instances, one or more components may be referred to herein as “configured to,” “configurable to,” “operable/operative to,” “adapted/adaptable,” “able to,” “conformable/conformed to,” etc. Those skilled in the art will recognize that “configured to” can generally encompass active-state components and/or inactive-state components and/or standby-state components, unless context requires otherwise.

[0182] While particular aspects of the present subject matter described herein have been shown and described, it will be apparent to those skilled in the art that, based upon the teachings herein, changes and modifications may be made without departing from the subject matter described herein and its broader aspects and, therefore, the appended claims are to encompass within their scope all such changes and modifications as are within the true spirit and scope of the subject matter described herein. It will be understood by those within the art that, in general, terms used herein, and especially in the appended claims (e.g., bodies of the appended claims) are generally intended as “open” terms (e.g., the term “including” should be interpreted as “including but not limited to,” the term “having” should be interpreted as “having at least,” the term “includes” should be interpreted as “includes but is not limited to,” etc.). It will be further understood by those within the art that if a specific number of an introduced claim recitation is intended, such an intent will be explicitly recited in the claim, and in the absence of such recitation no such intent is present. For example, as an aid to understanding, the following appended claims may contain usage of the introductory phrases “at least one” and “one or more” to introduce claim recitations. However, the use of such phrases should not be construed to imply that the introduction of a claim recitation by the indefinite articles “a” or “an” limits any particular claim containing such introduced claim recitation to claims containing only one such recitation, even when the same claim includes the introductory phrases “one or more” or “at least one” and indefinite articles such as “a” or “an” (e.g., “a” and/or “an” should typically be interpreted to mean “at least one” or “one or more”); the same holds true for the use of definite articles used to introduce claim recitations.

[0183] In addition, even if a specific number of an introduced claim recitation is explicitly recited, those skilled in the art will recognize that such recitation should typically be interpreted to mean at least the recited number (e.g., the bare recitation of “two recitations,” without other modifiers, typically means at least two recitations, or two or more recitations). Furthermore, in those instances where a convention analogous to “at least one of A, B, and C, etc.” is used, in general such a construction is intended in the sense one having skill in the art would understand the convention (e.g., “a system having at least one of A, B, and C” would include but not be limited to systems that have A alone, B alone, C alone, A and B together, A and C together, B and C together, and/or A, B, and C together, etc.). In those instances where a convention analogous to “at least one of A, B, or C, etc.” is used, in general such a construction is intended in the sense one having skill in the art would understand the convention (e.g., “a system having at least one of A, B, or C” would include but not be limited to systems that have A alone, B alone, C alone, A and B together, A and C together, B and C together, and/or A, B, and C together, etc.). It will be further understood by those within the art that typically a disjunctive word and/or phrase presenting two or more alternative terms, whether in the description, claims, or drawings, should be understood to contemplate the possibilities of including one of the terms, either of the terms, or both terms unless context dictates otherwise. For example, the phrase “A or B” will be typically understood to include the possibilities of “A” or “B” or “A and B.”

[0184] With respect to the appended claims, those skilled in the art will appreciate that recited operations therein may generally be performed in any order. Also, although various operational flows are presented in a sequence(s), it should be understood that the various operations may be performed in other orders than those which are illustrated, or may be performed concurrently. Examples of such alternate orderings may include overlapping, interleaved, interrupted, reordered, incremental, preparatory, supplemental, simultaneous, reverse, or other variant orderings, unless context dictates otherwise. Furthermore, terms like “responsive to,” “related to,” or other past-tense adjectives are generally not intended to exclude such variants, unless context dictates otherwise.

[0185] In certain cases, use of a system or method may occur in a territory even if components are located outside the territory. For example, in a distributed computing context, use of a distributed computing system may occur in a territory even though parts of the system may be located outside of the territory (e.g., relay, server, processor, signal-bearing medium, transmitting computer, receiving computer, etc. located outside the territory).

[0186] A sale of a system or method may likewise occur in a territory even if components of the system or method are located and/or used outside the territory. Further, implementation of at least part of a system for performing a method in one territory does not preclude use of the system in another territory.

[0187] Although various forms have been described herein, many modifications, variations, substitutions, changes, and equivalents to those forms may be implemented and will occur to those skilled in the art. Also, where materials are disclosed for certain components, other materials may be used. It is therefore to be understood that the foregoing description and the appended claims are intended to cover all such modifications and variations as falling within the scope of the disclosed forms. The following claims are intended to cover all such modification and variations.

[0188] In summary, numerous benefits have been described which result from employing the concepts described herein. The foregoing description of the one or more forms has been presented for purposes of illustration and description. It is not intended to be exhaustive or limiting to the precise form disclosed. Modifications or variations are possible in light of the above teachings. The one or more forms were chosen and described in order to illustrate principles and practical application to thereby enable one of ordinary skill in the art to utilize the various forms and with various modifications as are suited to the particular use contemplated. It is intended that the claims submitted herewith define the overall scope.

[0189] While several forms have been illustrated and described, it is not the intention of the applicant to restrict or limit the scope of the appended claims to such detail. Numerous variations, changes, and substitutions will occur to those skilled in the art without departing from the scope of the invention. Moreover, the structure of each element associated with the described forms can be alternatively described as a means for providing the function performed by the element. Accordingly, it is intended that the described forms be limited only by the scope of the appended claims.

[0190] Reference throughout the specification to “various forms,” “some forms,” “one form,” or “an form” means that a particular feature, structure, or characteristic described in connection with the form is included in at least one form. Thus, appearances of the phrases “in various forms,” “in some forms,” “in one form,” or “in an form” in places throughout the specification are not necessarily all referring to the same form. Furthermore, the particular features, structures, or

characteristics may be combined in any suitable manner in one or more forms. Thus, the particular features, structures, or characteristics illustrated or described in connection with one form may be combined, in whole or in part, with the features structures, or characteristics of one or more other forms without limitation.

[0191] Various aspects of the subject matter described herein are set out in the following numbered clauses:

[0192] 1. A system for managing RF and ultrasonic signals output by a generator, comprising: a surgical instrument comprising an RF energy output, an ultrasonic energy output, and a circuit configured to receive a combined Radio Frequency (RF) and ultrasonic signal from the generator; wherein the circuit is configured to filter frequency content of the combined signal and is configured to provide a first filtered signal to the RF energy output and a second filtered signal to the ultrasonic energy output.

[0193] 2. The system of clause 1, wherein the circuit comprises a resonator.

[0194] 3. The system of clause 1 or 2, wherein the circuit comprises a high frequency band-stop filter.

[0195] 4. The system of any one of clauses 1-3, wherein the high frequency band-stop filter comprises a first LC filter circuit and a second LC filter circuit.

[0196] 5. The system of any one of clauses 1-4, wherein the combined signal comprises a 350kHz component.

[0197] 6. The system of any one of clauses 1-5, wherein the combined signal comprises a 55kHz component.

[0198] 7. The system of any of clauses 1-6, wherein the surgical instrument is configured to apply a therapy from the RF energy output and the ultrasonic energy output simultaneously.

[0199] 8. A system for managing RF and ultrasonic signals output by a generator, comprising: a surgical instrument comprising an RF energy output, an ultrasonic energy output, and a circuit configured to receive a combined Radio Frequency (RF) and ultrasonic signal from the generator; wherein the circuit is configured to switch between the RF energy output and the ultrasonic energy output according to the combined signal received from the generator.

[0200] 9. The system of clause 8, wherein the circuit comprises two pairs of MOSFET switches.

[0201] 10. The system of clause 9, wherein each of the two pairs of MOSFET switches is connected source to source.

[0202] 11. The system of clause 9 or 10, further comprising a first coupled inductor and a second coupled inductor.

[0203] 12. The system of clause 11, wherein the gate of each MOSFET of a first pair of MOSFET switches is coupled together and is coupled to the first coupled inductor.

[0204] 13. The system of clause 11 or 12, wherein the gate of each MOSFET of a second pair of MOSFET switches is coupled together and is coupled to the second coupled inductor.

[0205] 14. The system of any of clauses 11-13, further comprising a first capacitor and a second capacitor, wherein the first capacitor is coupled to the primary side of the first coupled inductor and the second capacitor is coupled to the primary side of the second coupled inductor.

[0206] 15. The system of any one of clauses 9-14, further comprising an ASIC, a first pulse transformer, and a second pulse transformer, wherein the ASIC is coupled to the first and second pulse transformers, and wherein the first pulse transformer is coupled to a first pair of the two pairs of MOSFET switches and the second pulse transformer is coupled to a second pair of the two pairs of MOSFET switches.

[0207] 16. The system of clause 15, wherein each of the two pairs of MOSFET switches are connected source to source.

[0208] 17. The system of clause 16, wherein the gate of each MOSFET of the first pair of MOSFET switches is coupled together and is coupled to the first pulse transformer.

[0209] 18. The system of clause 16 or 17, wherein the gate of each MOSFET of a second pair of MOSFET switches is coupled together and is coupled to the second pulse transformer.

[0210] 19. The system of clause 18, wherein the circuit comprises a first switching element coupled to the RF energy output and a second switching element coupled to the ultrasonic energy output.

[0211] 20. The system of clause 19, wherein the first switching element and the second switching element are each electromechanical relays.

[0212] 21. The system of clause 19 or 20, wherein the first switching element and the second switching element are coupled to an ASIC.

[0213] 22. The system of any one of clauses 19-21, further comprising a switch mechanism to actuate the first switching element and the second switching element.

[0214] 23. The system of clause 22, wherein the switch mechanism is a mechanical rocker style switch mechanism.

[0215] 24. A system for managing RF and ultrasonic signals output by a generator, comprising: a surgical instrument comprising an RF energy output, an ultrasonic energy output, and a circuit configured to receive a combined Radio Frequency (RF) and ultrasonic signal from the generator; wherein the circuit comprises: a filter circuit configured to filter frequency content of the combined signal; and a switching element configured to switch between an on-state and an off-state to one of the RF energy output or the ultrasonic energy output according to the combined signal received from the generator.

[0216] 25. The system of clause 24, wherein the filter circuit is coupled to the ultrasonic energy output and the switching element is coupled to the RF energy output.

[0217] 26. A method for operating a surgical instrument, the surgical instrument comprising a radio frequency (RF) energy output, an ultrasonic energy output, and a first jaw and a second jaw configured for pivotal movement between a closed position and an open position, the method comprising: receiving a first input indicating a user selection of one of a first option and a second option; receiving a second input indicating whether the first jaw and the second jaw are in the closed position or in the open position; receiving a third input indicating electrical impedance at the RF energy output; and selecting a mode of operation for treating a tissue from a plurality of modes of operation based at least in part on the first input, the second input and the third input, wherein the plurality of modes of operation comprises: a first mode wherein the RF energy output applies RF energy to the tissue; and a second mode wherein the ultrasonic energy output applies ultrasonic energy to the tissue.

[0218] 27. The method of clause 26, wherein the first option is a seal only option, and the second option is a seal and cut option.

[0219] 28. The method of clause 26, wherein the user selection is a button selection.

[0220] 29. The method of clause 26, wherein the plurality of modes of operation further comprises: a third mode wherein the RF energy output applies RF energy to the tissue and the ultrasonic energy output applies ultrasonic energy to the tissue; and a fourth mode wherein no RF energy or ultrasonic energy is applied to the tissue.

[0221] 30. The method of clause 29, wherein the third mode is selected when the first input indicates the second option, the second input indicates the closed position, and the third input indicates medium electrical impedance, wherein RF energy is applied before ultrasonic energy is applied.

[0222] 31. The method of clause 29, wherein the fourth mode is selected when the first input indicates the first option, the second input indicates the open position, and the third input indicates high electrical impedance.

[0223] 32. The method of clause 26, further comprising selecting a level of energy applied by the RF energy output based at least in part on the first input, the second input and the third input.

[0224] 33. The method of clause 32, wherein the first mode is selected and the level of energy applied by the RF energy output is selected as high, when the second input indicates the open position, and the third input indicates medium electrical impedance.

[0225] 34. The method of clause 26, further comprising selecting a level of energy applied by the ultrasonic energy output based at least in part on the first input, the second input and the third input.

[0226] 35. The method of clause 34, wherein the second mode is selected and the level of energy applied by the ultrasonic energy output is selected as low, when the second input indicates the closed position, and the third input indicates low electrical impedance.

[0227] 36. The method of clause 34, wherein the second mode is selected and the level of energy applied by the ultrasonic energy output is selected as high, when the first input indicates the second option, the second input indicates the open position, and the third input indicates high electrical impedance.

[0228] 37. The method of clause 26, wherein the first mode is selected when the first input indicates the first option, the second input indicates the closed position, and the third input indicates medium electrical impedance.

[0229] 38. The method of clause 26, further comprising selecting a waveform of energy applied by the RF energy output or the ultrasonic energy output based at least in part on the first input, the second input and the third input.

[0230] 39. A generator for delivering radio frequency (RF) energy and ultrasonic energy to a surgical instrument, the surgical instrument comprising a first jaw and a second jaw configured for pivotal movement between a closed position and an open position, the generator being configured to: receive a first input indicating a user selection of one of a first option and a second option; receive a second input indicating whether the first jaw and the second jaw are in the closed position or in the open position; receive a third input indicating electrical impedance at a RF energy output of the surgical instrument; and select a mode of operation for treating a tissue from a plurality of modes of operation based at least in part on the first input, the second input and the third input, wherein the plurality of modes of operation comprises: a first mode wherein the generator delivers RF energy to the surgical instrument; and a second mode wherein the generator delivers ultrasonic energy to the surgical instrument.

[0231] 40. The generator of clause 39, wherein the plurality of modes of operation further comprises: a third mode wherein the generator delivers RF energy and ultrasonic energy to the surgical instrument; and a fourth mode wherein the generator delivers no RF energy or ultrasonic energy to the surgical instrument.

[0232] 41. The generator of clause 39, wherein the generator is further configured to deliver RF energy to the surgical instrument at a level determined based at least in part on the first input, the second input and the third input.

[0233] 42. The generator of clause 41, wherein the generator is configured to select the first mode and the level of RF energy is determined as high, when the second input indicates the open position, and the third input indicates medium electrical impedance.

[0234] 43. The generator of clause 39, wherein the generator is further configured to deliver ultrasonic energy to the surgical instrument at a level determined based at least in part on the first input, the second input and the third input.

[0235] 44. The generator of clause 43, wherein the generator is configured to select the second mode and the level of ultrasonic energy is determined as low, when the second input indicates the closed position, and the third input indicates low electrical impedance.

[0236] 45. A surgical instrument comprising: a first jaw and a second jaw configured for pivotal movement between a closed position and an open position; a radio frequency (RF) energy output configured to apply RF energy to a tissue at least when a first mode of operation is selected; and an ultrasonic energy output configured to apply ultrasonic energy to the tissue at least when a second mode of operation is selected, wherein a mode of operation is selected from a plurality of modes of operation comprising the first mode and the second mode based at least in part on a first input, a second input and a third input, wherein: the first input indicates a user selection of one of a first option and a second option; the second input indicates whether the first jaw and the second jaw are in the closed position or in the open position; and the third input indicates electrical impedance at the RF energy output.

CLAIMS

1. A method for operating a surgical instrument, the surgical instrument comprising a radio frequency (RF) energy output, an ultrasonic energy output, and a first jaw and a second jaw configured for pivotal movement between a closed position and an open position, the method comprising:

receiving a first input indicating a user selection of one of a first option and a second option;

receiving a second input indicating whether the first jaw and the second jaw are in the closed position or in the open position;

receiving a third input indicating electrical impedance at the RF energy output; and

selecting a mode of operation for treating a tissue from a plurality of modes of operation based at least in part on the first input, the second input and the third input, wherein the plurality of modes of operation comprises:

a first mode wherein the RF energy output applies RF energy to the tissue;

and

a second mode wherein the ultrasonic energy output applies ultrasonic energy to the tissue.

2. The method of claim 1, wherein the first option is a seal only option, and the second option is a seal and cut option.

3. The method of claim 1, wherein the user selection is a button selection.

4. The method of claim 1, wherein the plurality of modes of operation further comprises:

a third mode wherein the RF energy output applies RF energy to the tissue and the ultrasonic energy output applies ultrasonic energy to the tissue; and

a fourth mode wherein no RF energy or ultrasonic energy is applied to the tissue.

5. The method of claim 4, wherein the third mode is selected when the first input indicates the second option, the second input indicates the closed position, and the third input indicates medium electrical impedance, wherein RF energy is applied before ultrasonic energy is applied.

6. The method of claim 4, wherein the fourth mode is selected when the first input indicates the first option, the second input indicates the open position, and the third input indicates high electrical impedance.

7. The method of claim 1, further comprising selecting a level of energy applied by the RF energy output based at least in part on the first input, the second input and the third input.

8. The method of claim 7, wherein the first mode is selected and the level of energy applied by the RF energy output is selected as high, when the second input indicates the open position, and the third input indicates medium electrical impedance.

9. The method of claim 1, further comprising selecting a level of energy applied by the ultrasonic energy output based at least in part on the first input, the second input and the third input.

10. The method of claim 9, wherein the second mode is selected and the level of energy applied by the ultrasonic energy output is selected as low, when the second input indicates the closed position, and the third input indicates low electrical impedance.

11. The method of claim 9, wherein the second mode is selected and the level of energy applied by the ultrasonic energy output is selected as high, when the first input indicates the second option, the second input indicates the open position, and the third input indicates high electrical impedance.

12. The method of claim 1, wherein the first mode is selected when the first input indicates the first option, the second input indicates the closed position, and the third input indicates medium electrical impedance.

13. The method of claim 1, further comprising selecting a waveform of energy applied by the RF energy output or the ultrasonic energy output based at least in part on the first input, the second input and the third input.

14. A generator for delivering radio frequency (RF) energy and ultrasonic energy to a surgical instrument, the surgical instrument comprising a first jaw and a second jaw configured for pivotal movement between a closed position and an open position, the generator being configured to:

receive a first input indicating a user selection of one of a first option and a second option;

receive a second input indicating whether the first jaw and the second jaw are in the closed position or in the open position;

receive a third input indicating electrical impedance at a RF energy output of the surgical instrument; and

select a mode of operation for treating a tissue from a plurality of modes of operation based at least in part on the first input, the second input and the third input, wherein the plurality of modes of operation comprises:

a first mode wherein the generator delivers RF energy to the surgical instrument; and

a second mode wherein the generator delivers ultrasonic energy to the surgical instrument.

15. The generator of claim 14, wherein the plurality of modes of operation further comprises:

a third mode wherein the generator delivers RF energy and ultrasonic energy to the surgical instrument; and

a fourth mode wherein the generator delivers no RF energy or ultrasonic energy to the surgical instrument.

16. The generator of claim 14, wherein the generator is further configured to deliver RF energy to the surgical instrument at a level determined based at least in part on the first input, the second input and the third input.

17. The generator of claim 16, wherein the generator is configured to select the first mode and the level of RF energy is determined as high, when the second input indicates the open position, and the third input indicates medium electrical impedance.

18. The generator of claim 14, wherein the generator is further configured to deliver ultrasonic energy to the surgical instrument at a level determined based at least in part on the first input, the second input and the third input.

19. The generator of claim 18, wherein the generator is configured to select the second mode and the level of ultrasonic energy is determined as low, when the second input indicates the closed position, and the third input indicates low electrical impedance.

20. A surgical instrument comprising:

a first jaw and a second jaw configured for pivotal movement between a closed position and an open position;

a radio frequency (RF) energy output configured to apply RF energy to a tissue at least when a first mode of operation is selected; and

an ultrasonic energy output configured to apply ultrasonic energy to the tissue at least when a second mode of operation is selected, wherein

a mode of operation is selected from a plurality of modes of operation comprising the first mode and the second mode based at least in part on a first input, a second input and a third input, wherein:

the first input indicates a user selection of one of a first option and a second option;

the second input indicates whether the first jaw and the second jaw are in the closed position or in the open position; and

the third input indicates electrical impedance at the RF energy output.

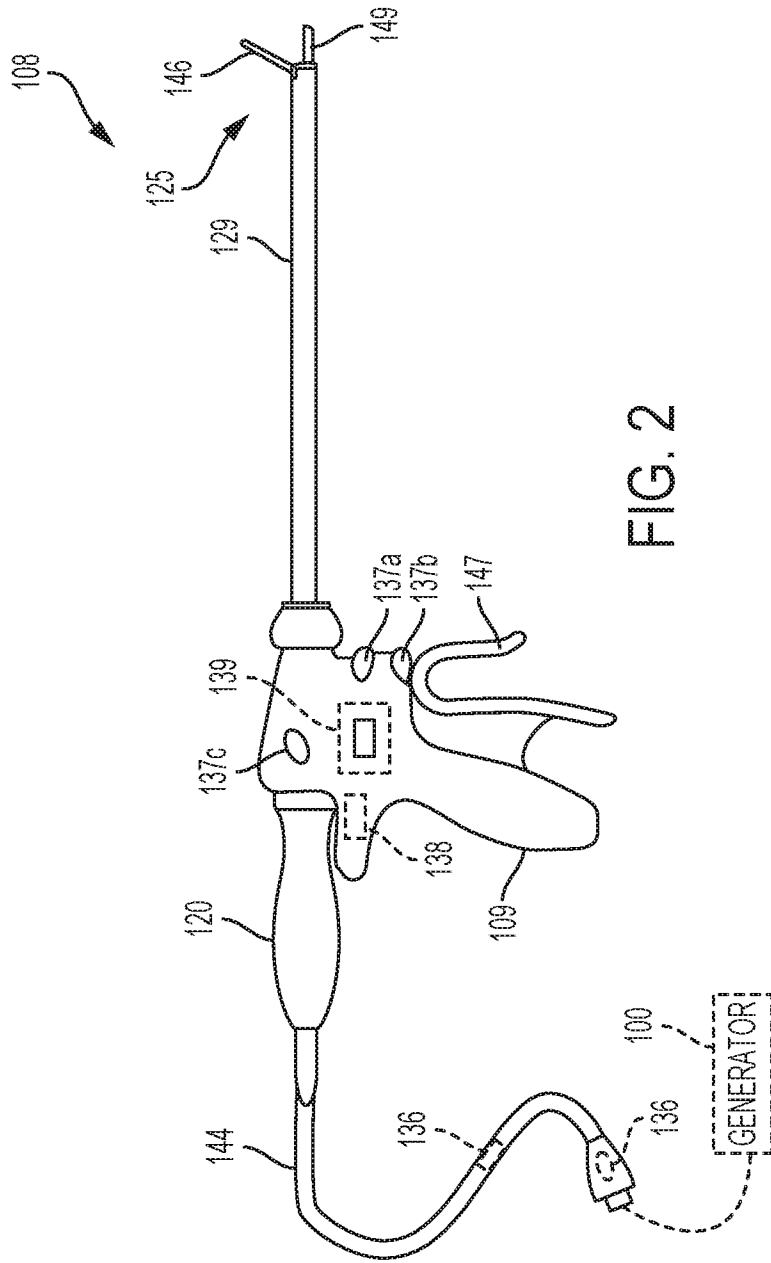

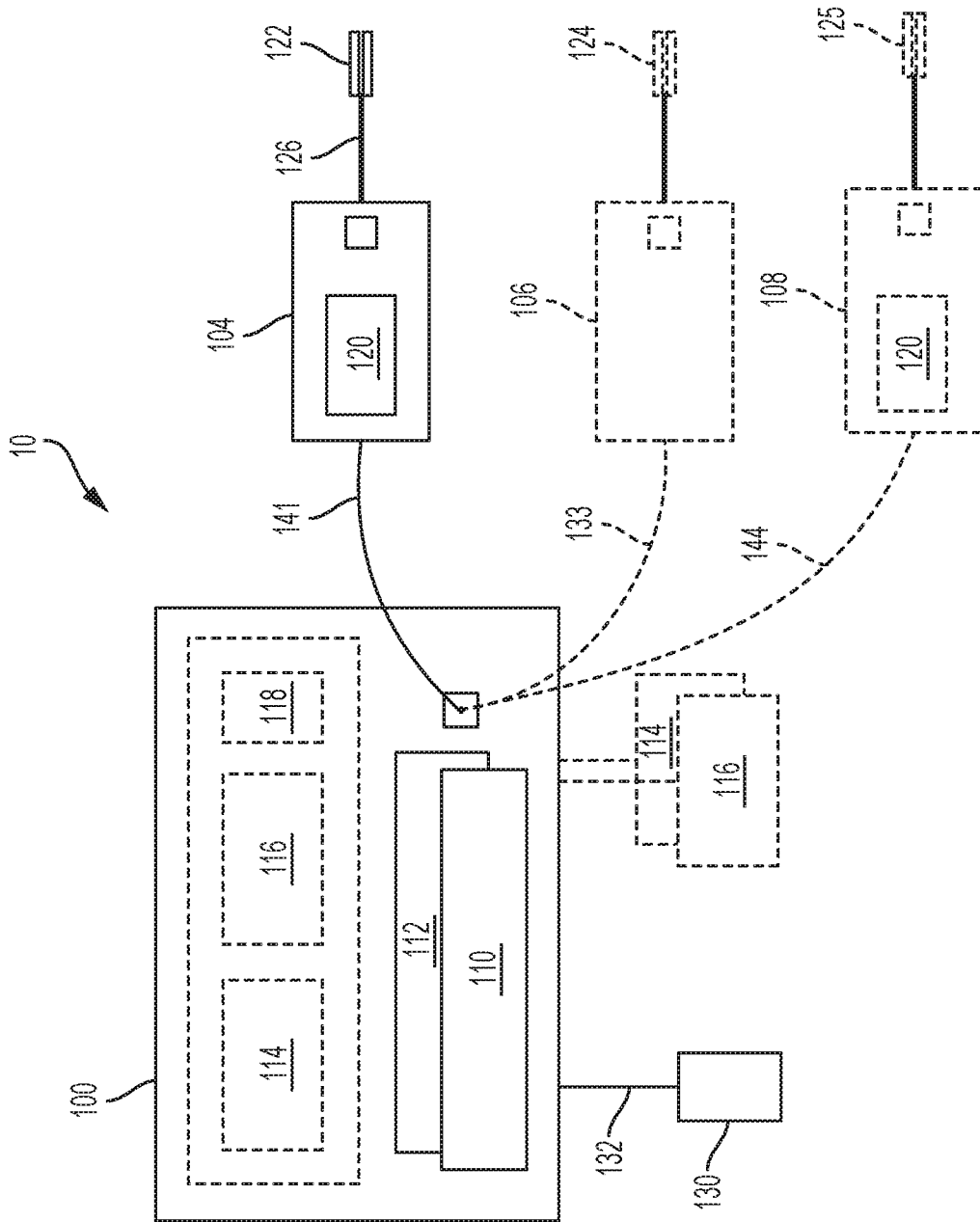

FIG. 3

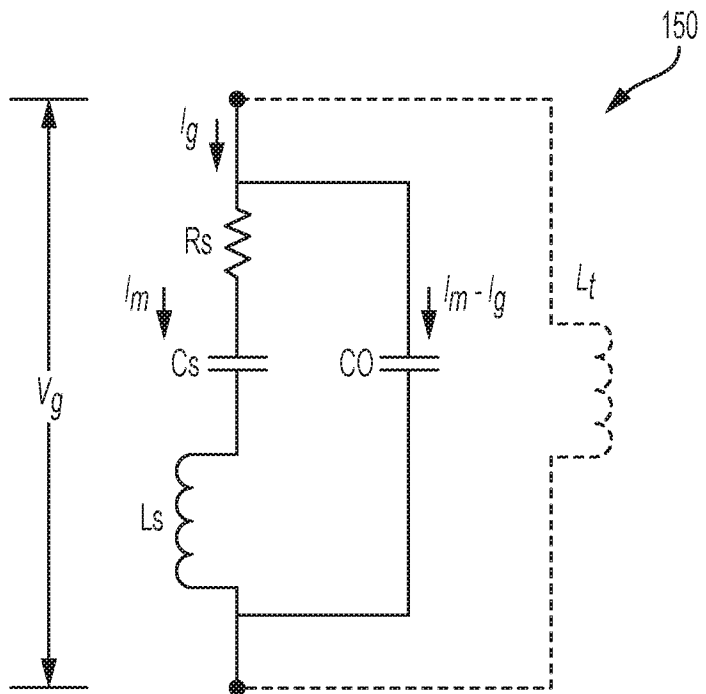

FIG. 4

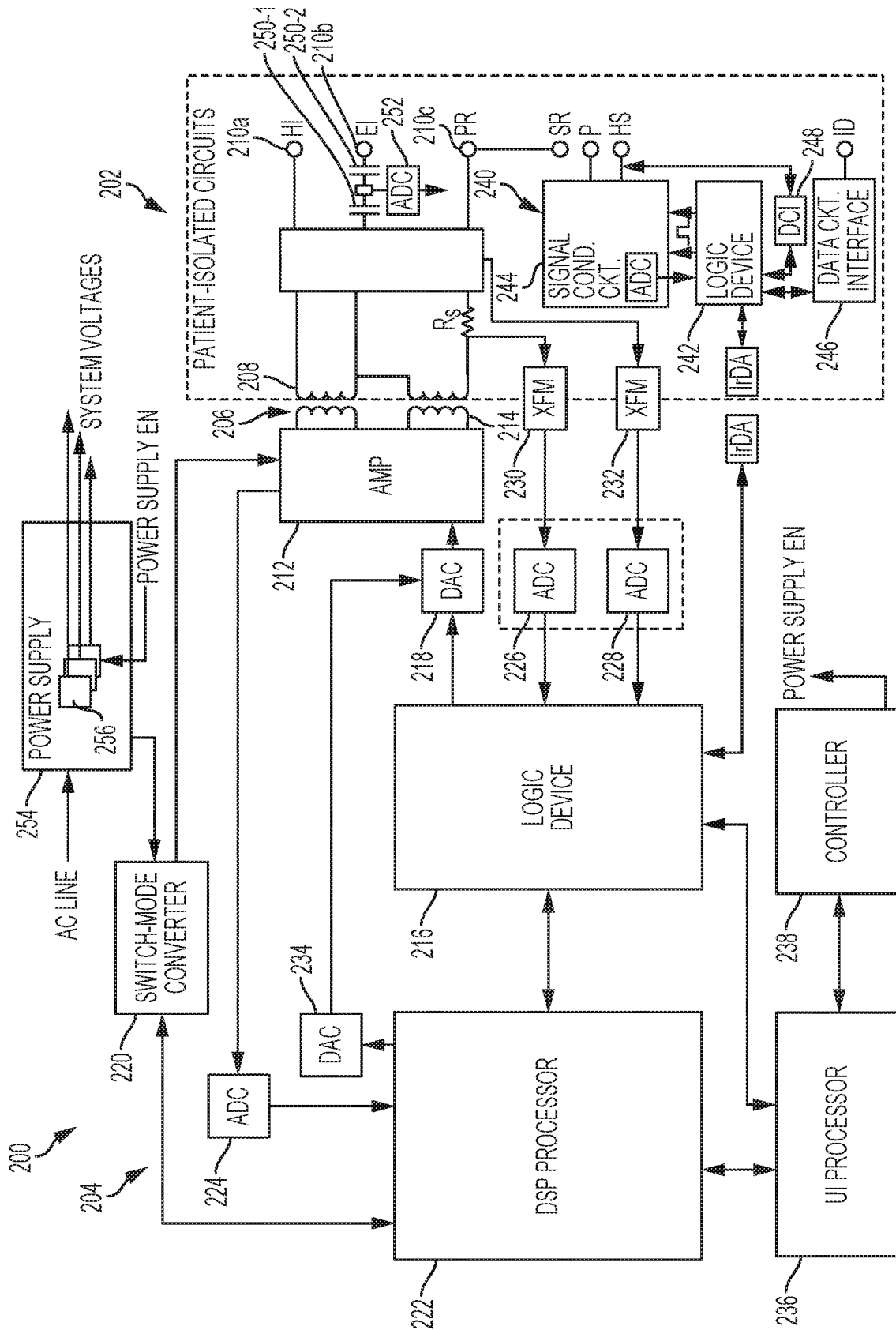

FIG. 5

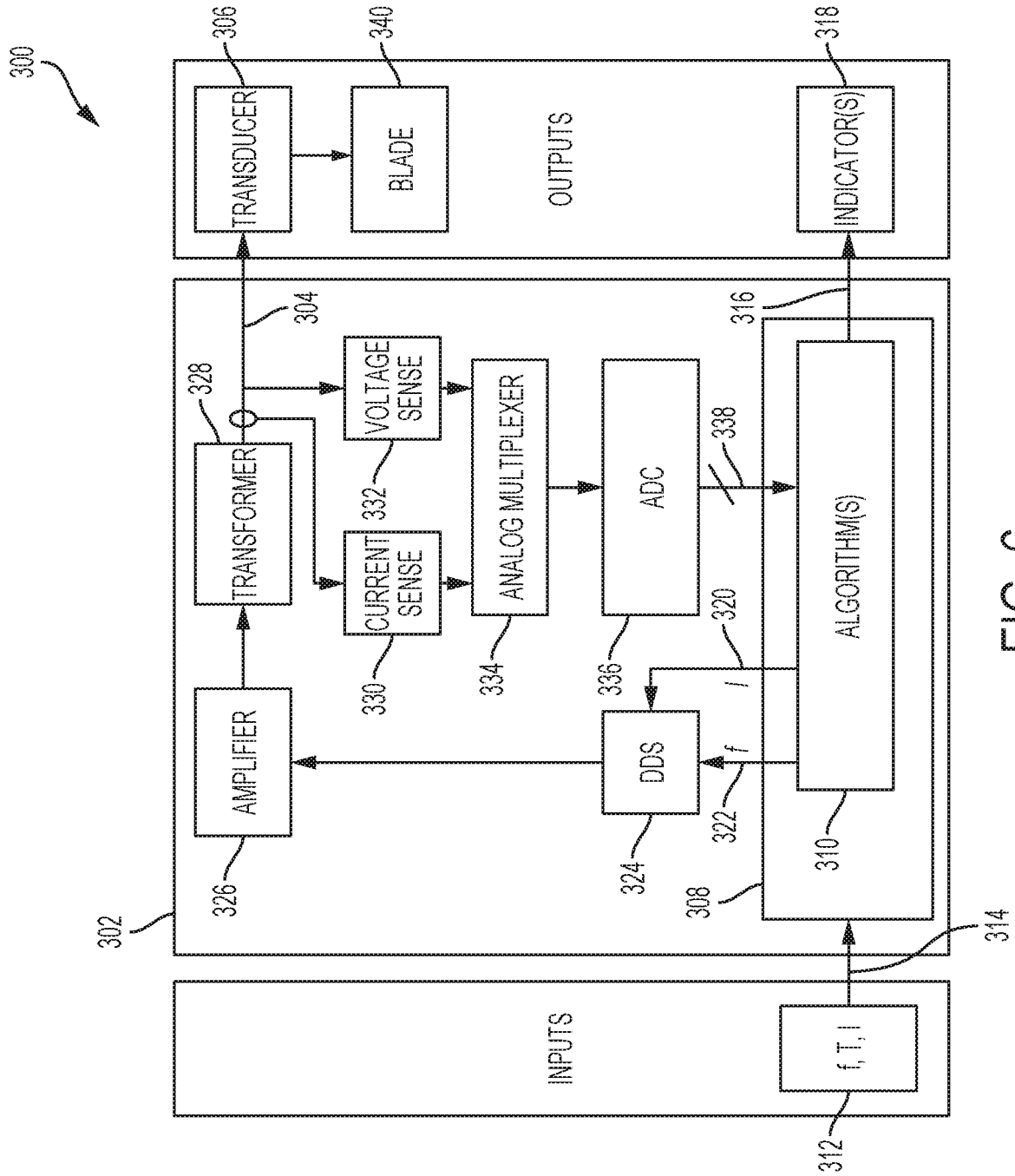

FIG. 6

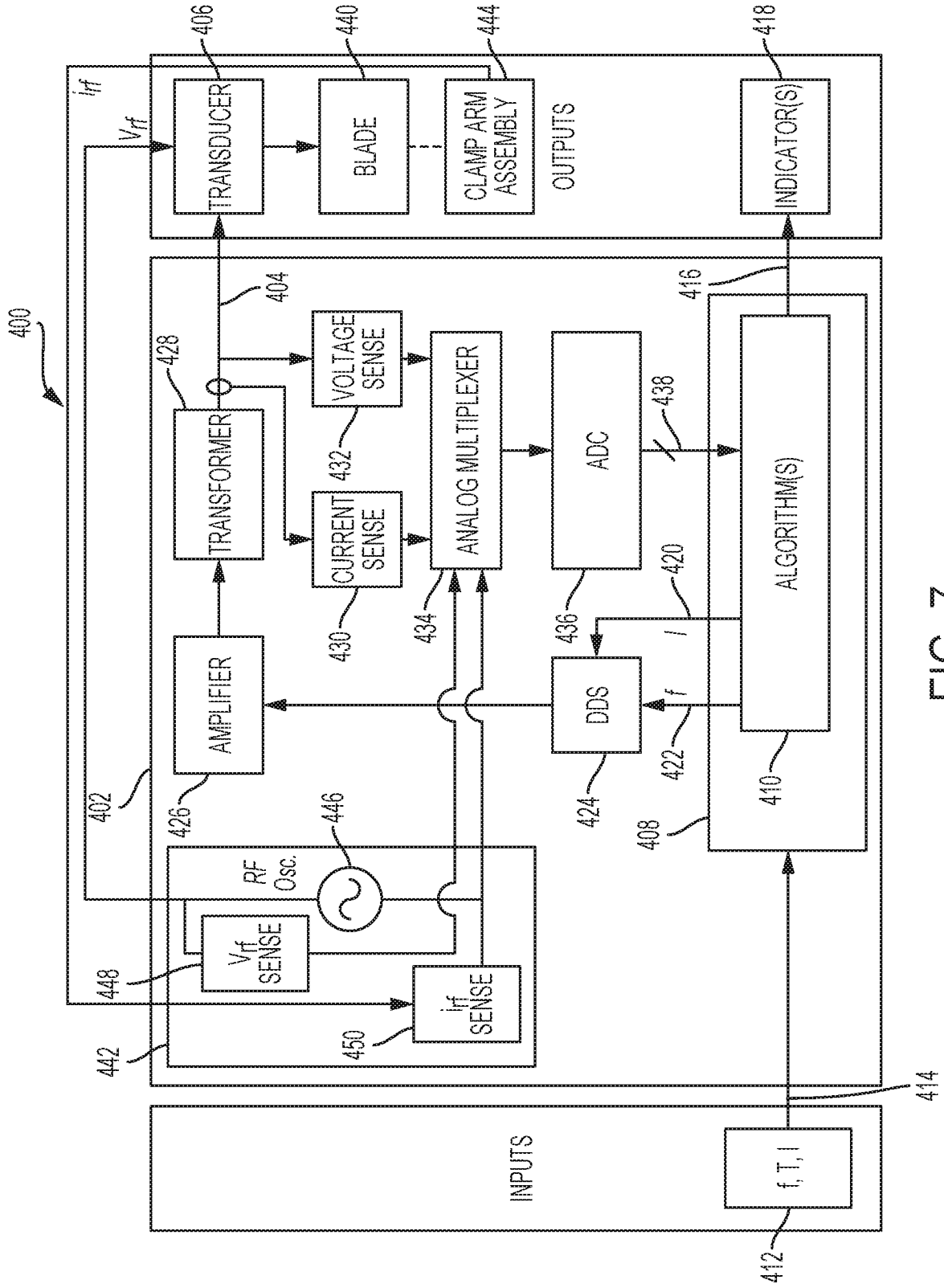

FIG. 7

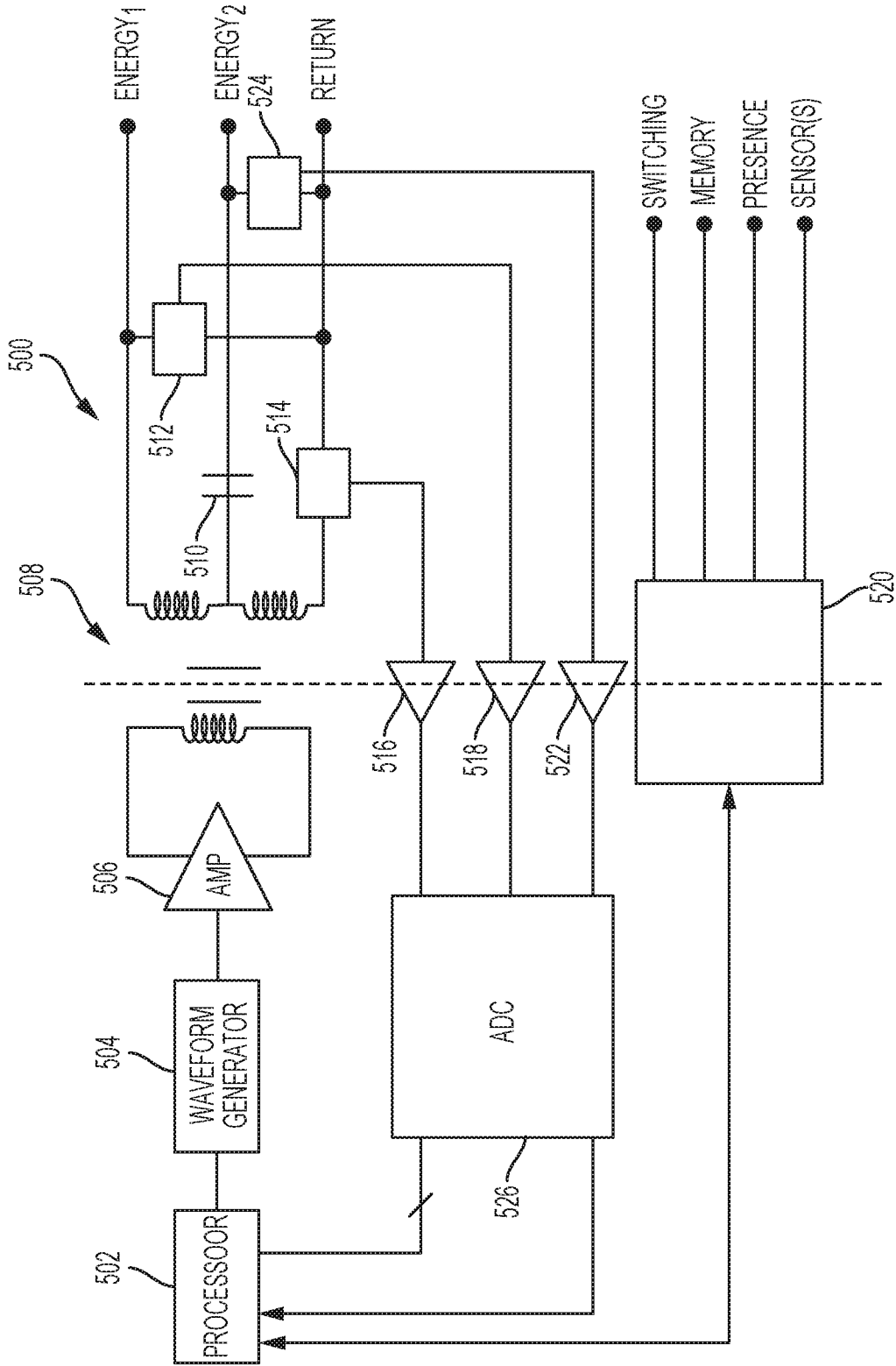

FIG. 8

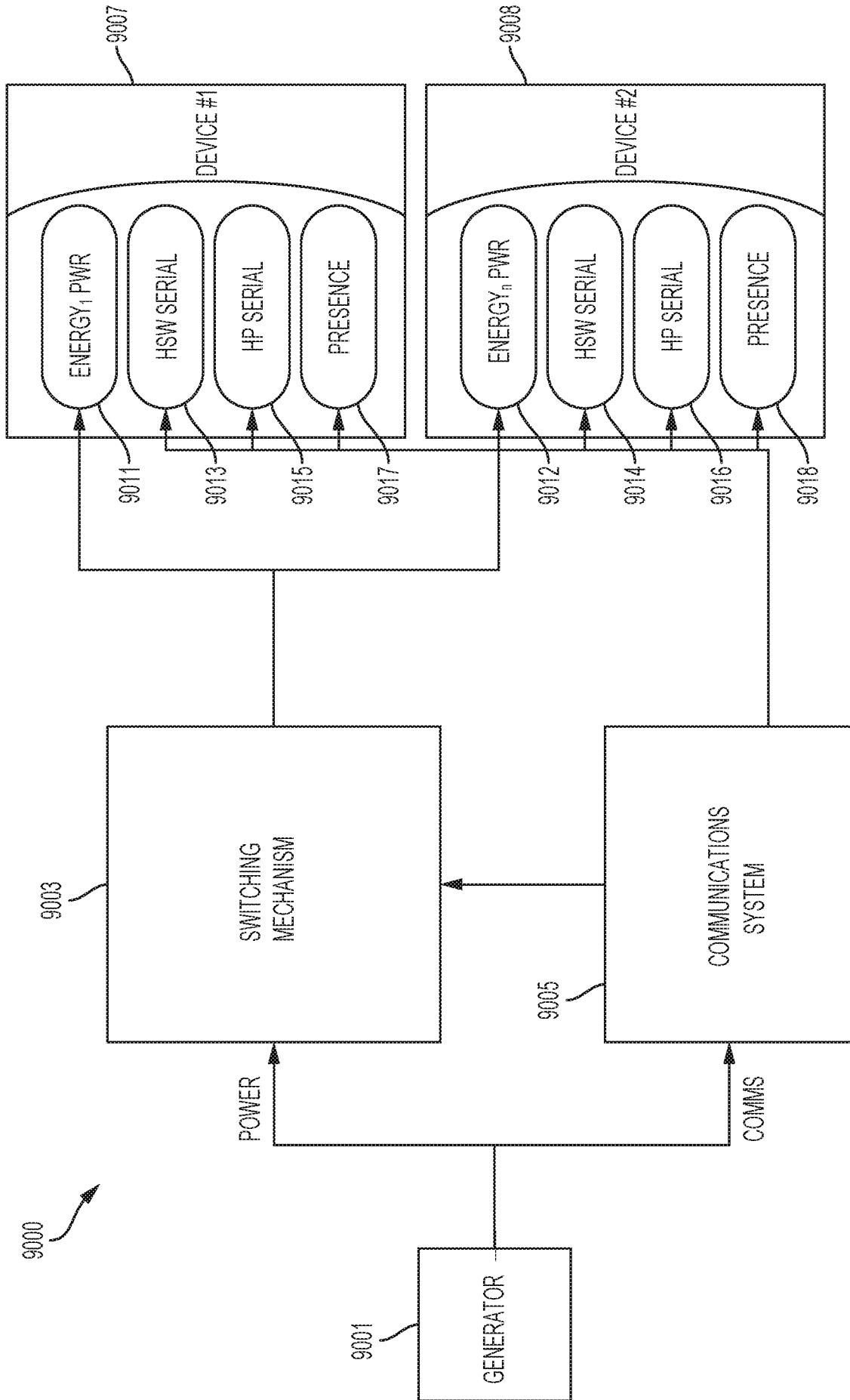

FIG. 9

1001

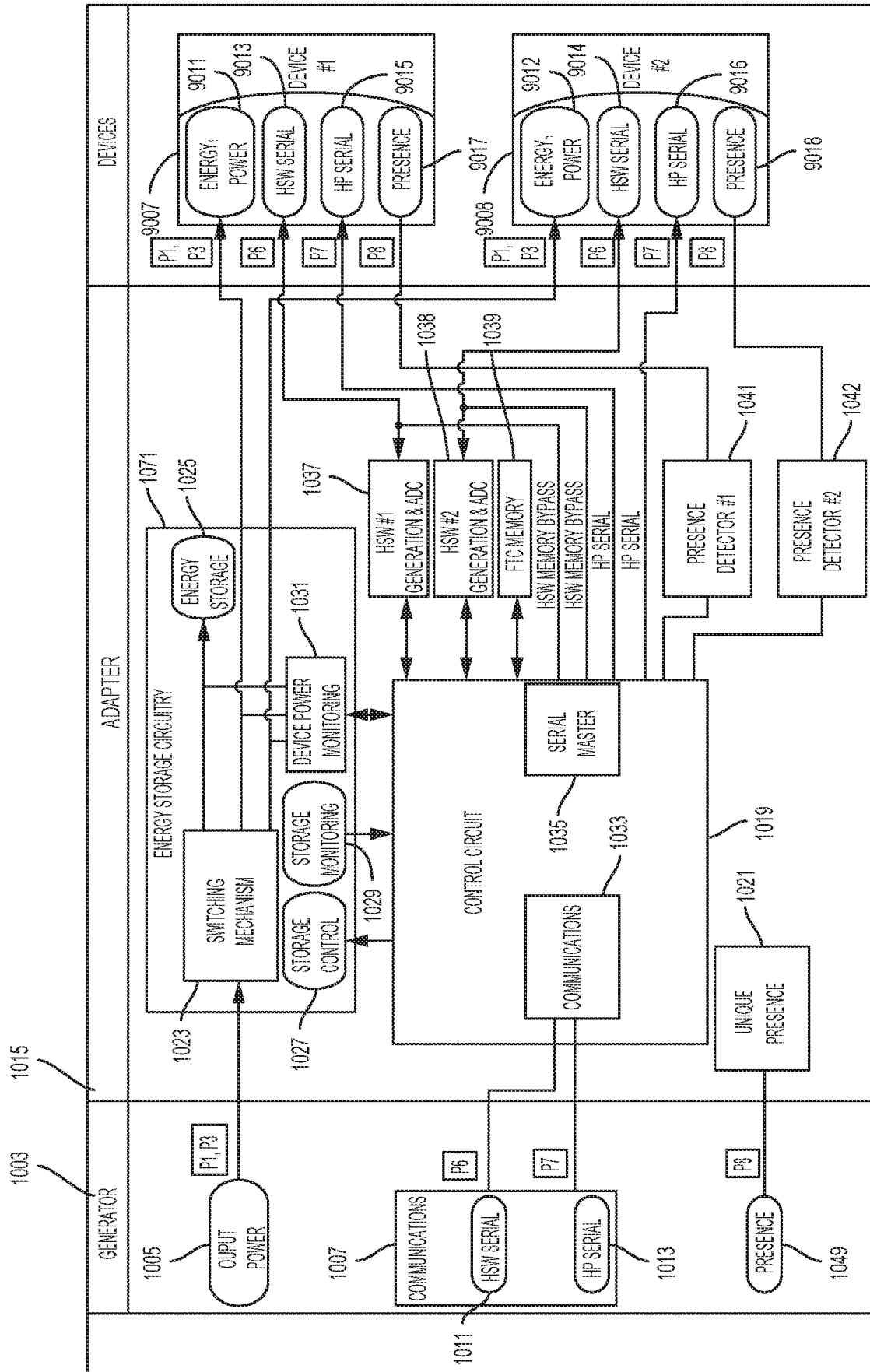

FIG. 10

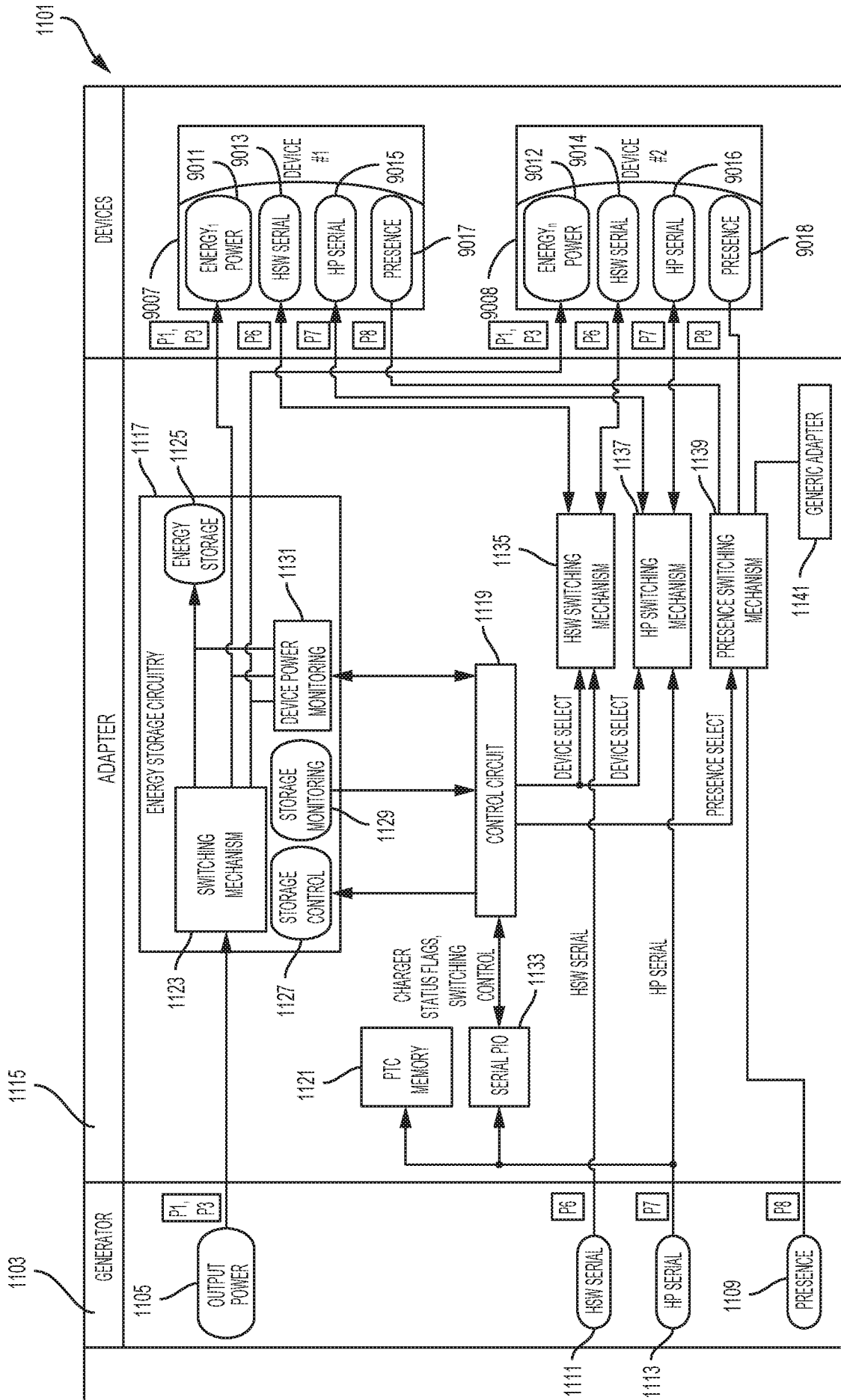

FIG. 11

12/19

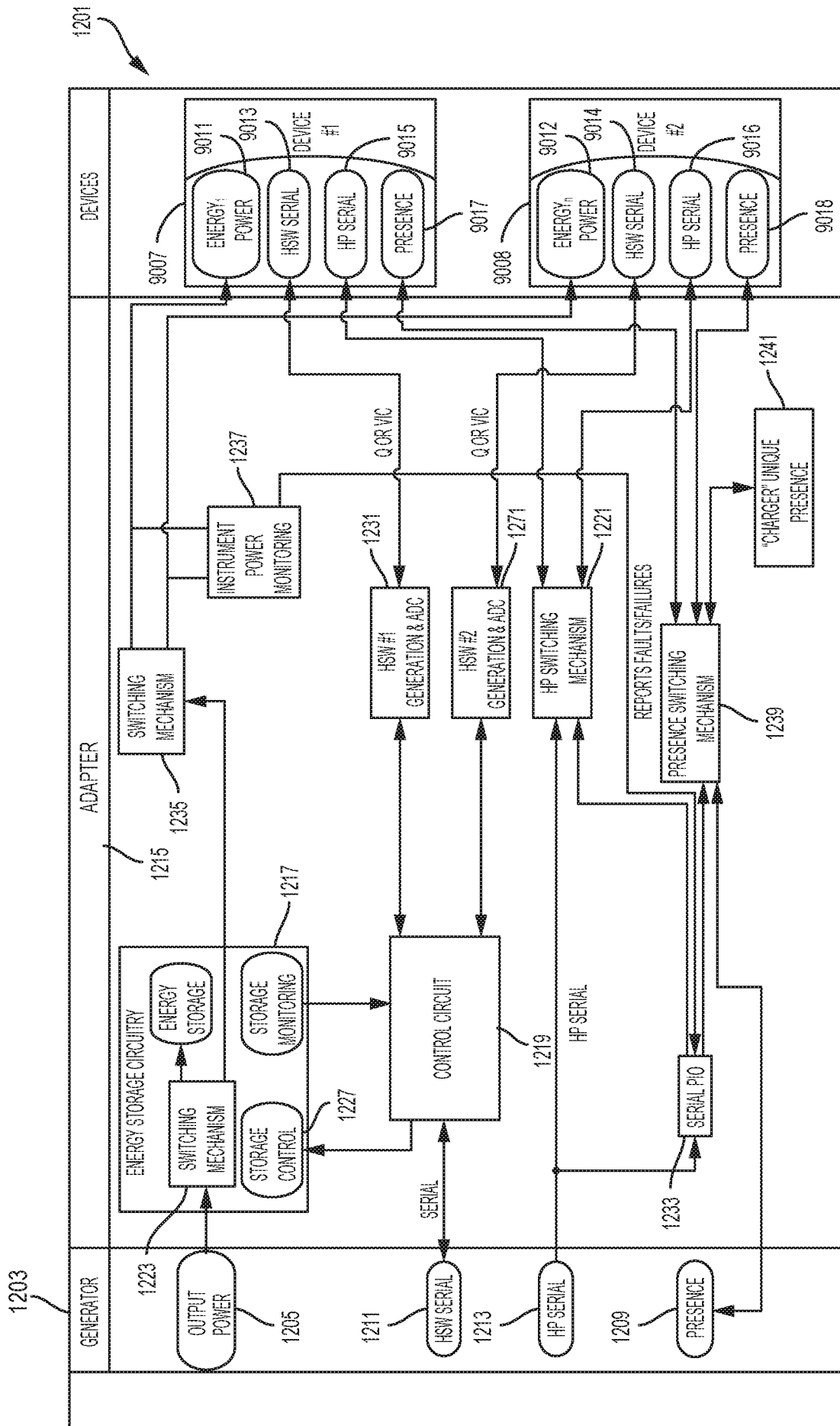

FIG. 12

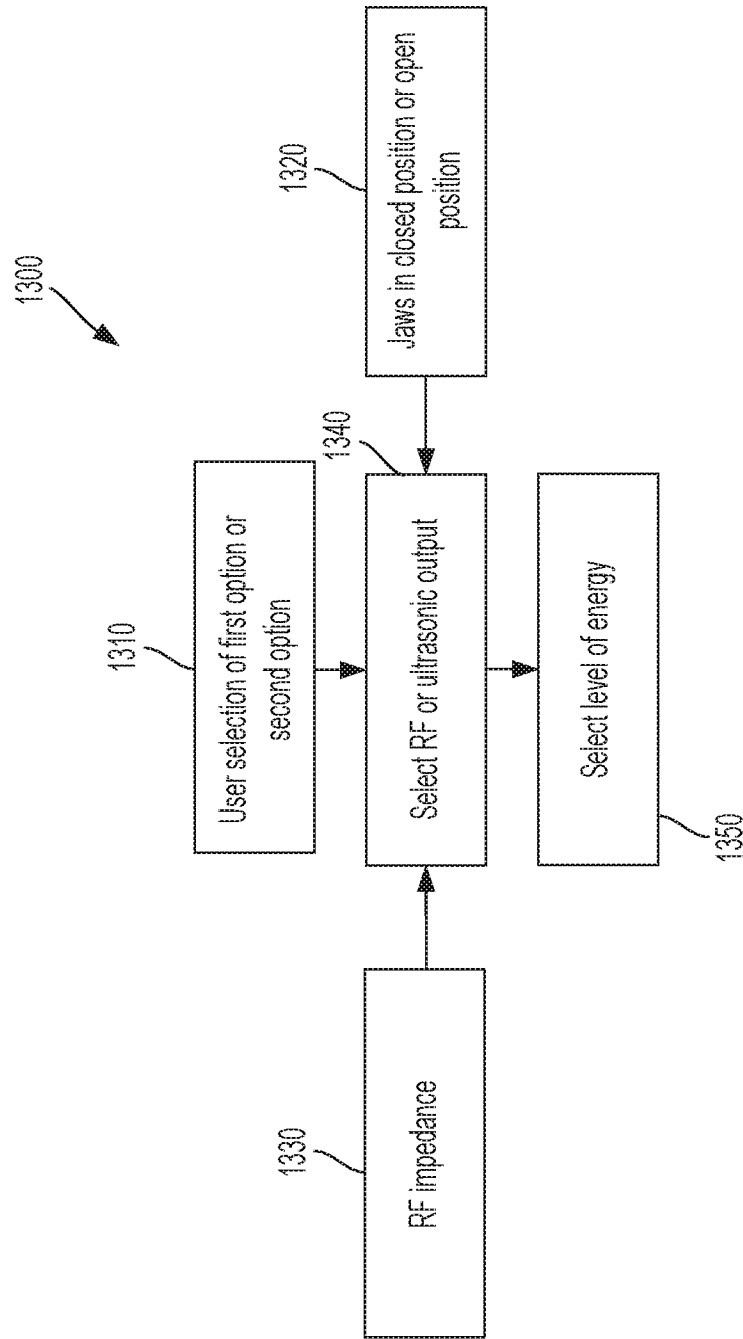

FIG. 13

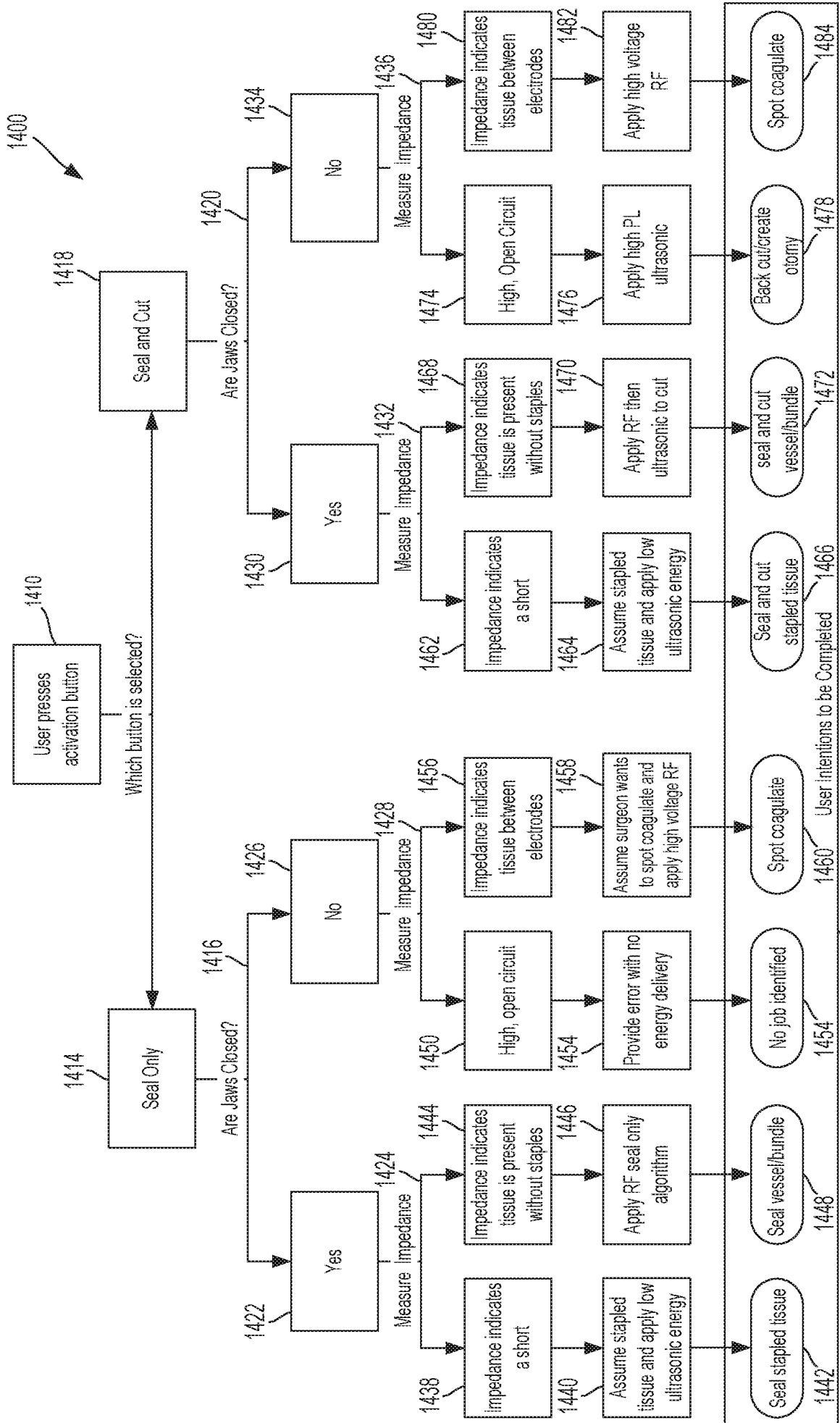

FIG. 14

1490

6600 ↗

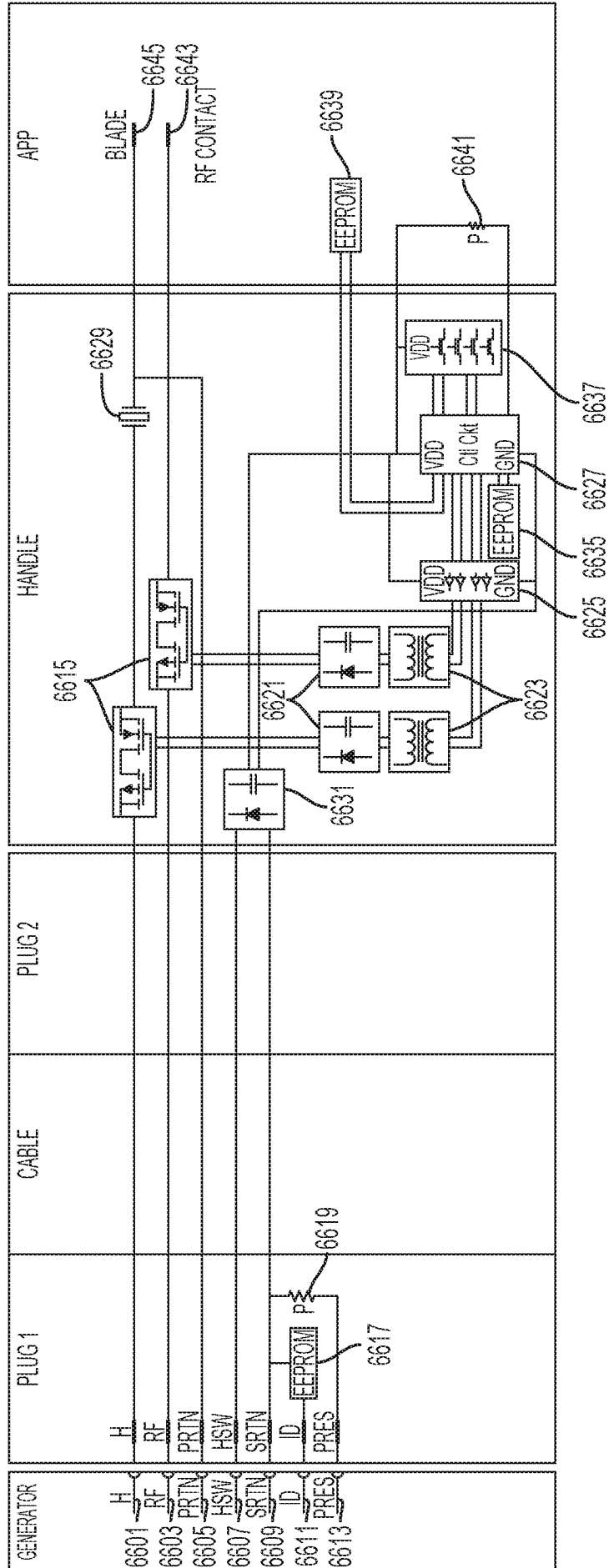

FIG. 15

6900 ↗

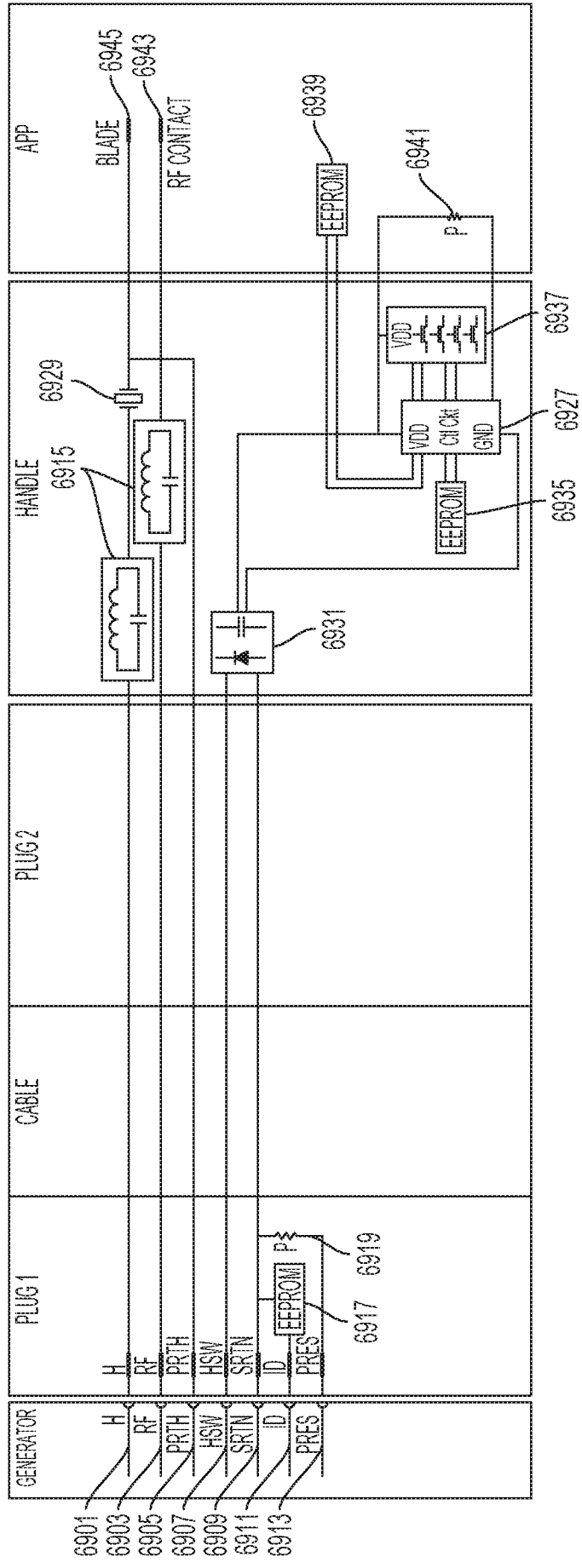

FIG. 16

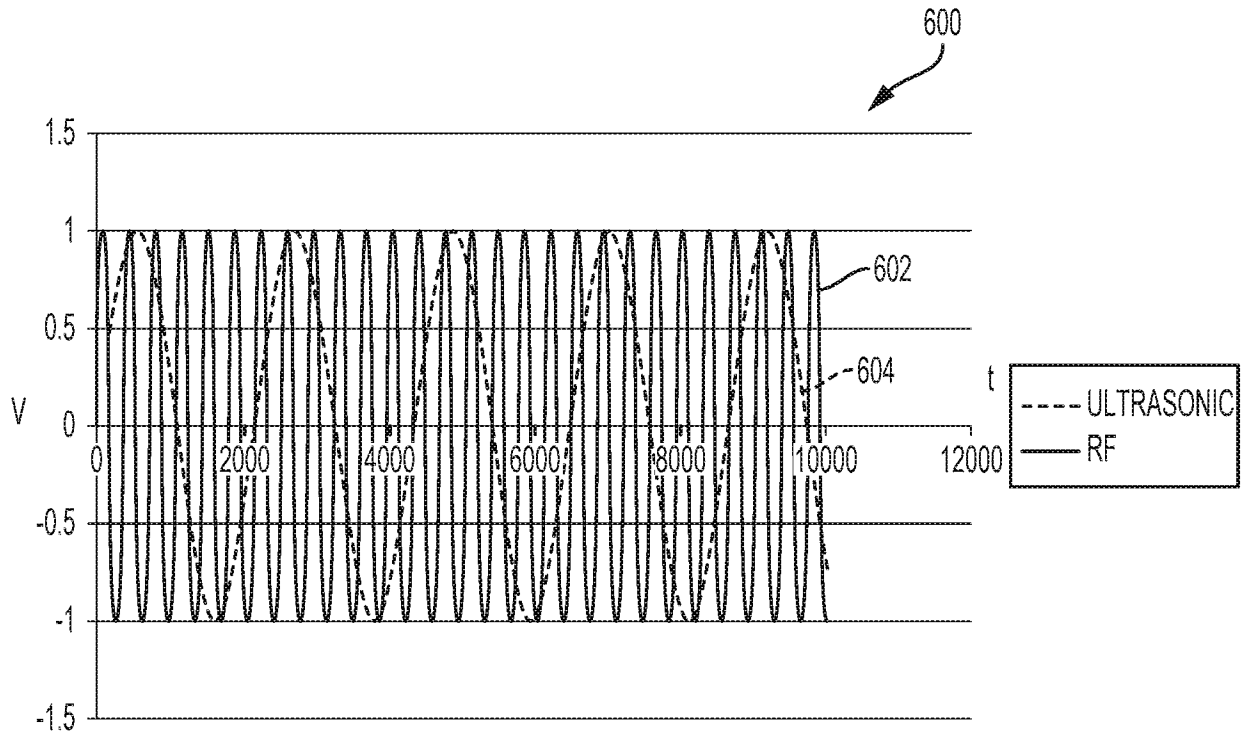

FIG. 17

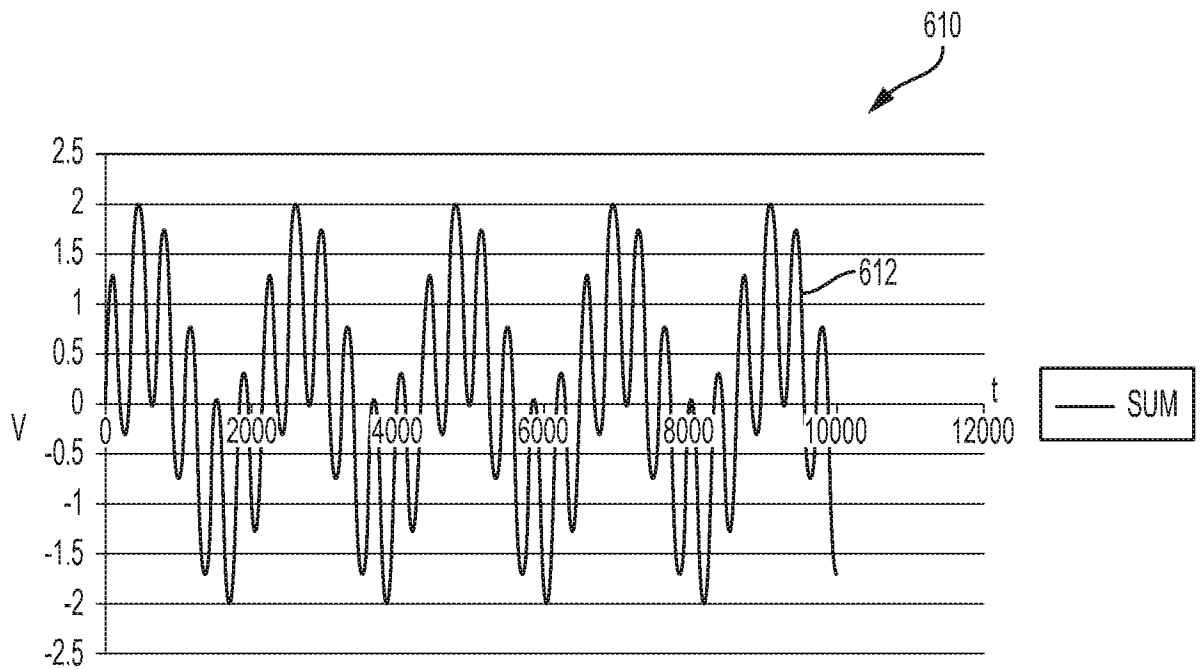

FIG. 18

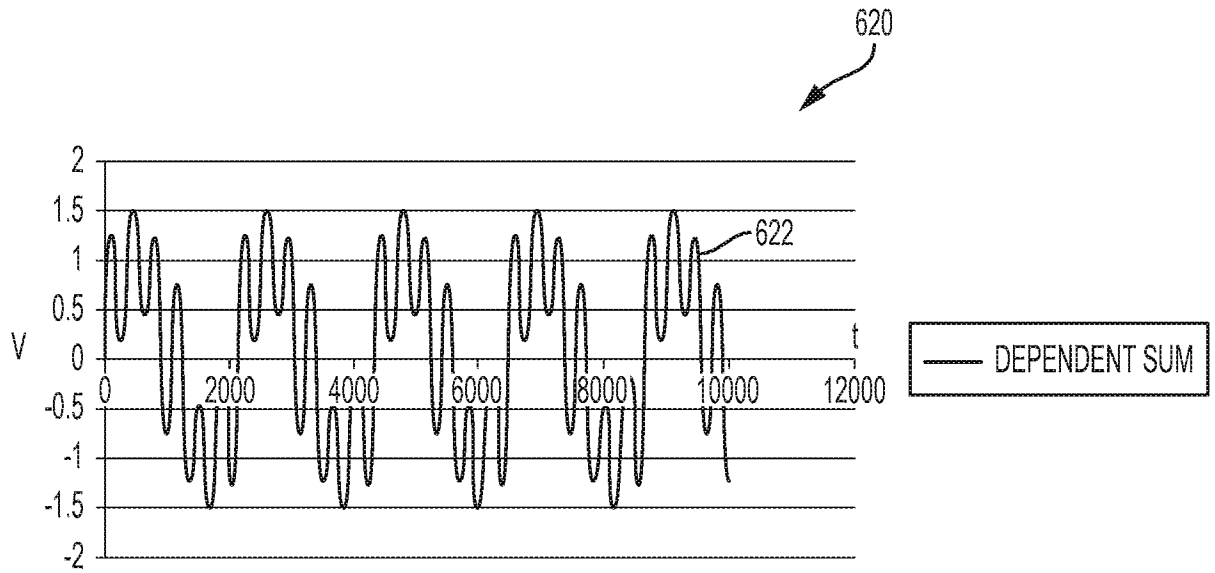

FIG. 19

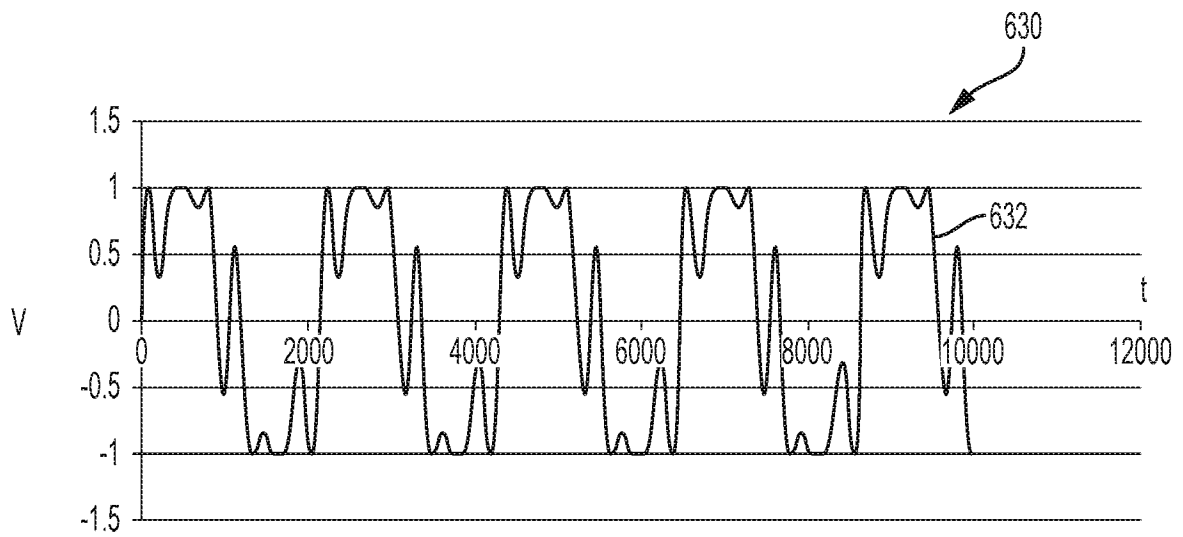

FIG. 20

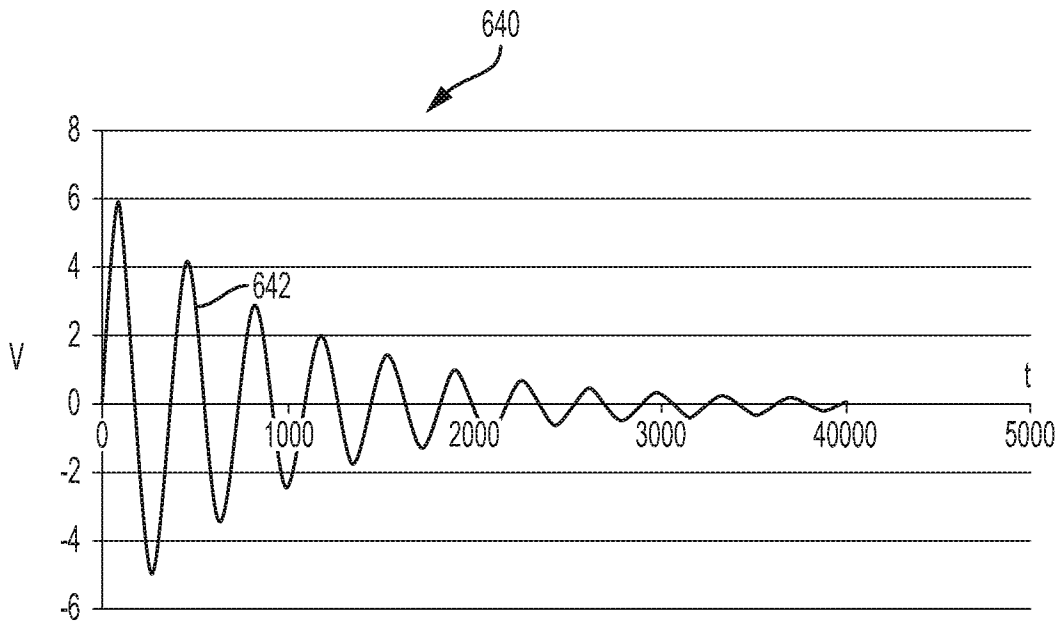

FIG. 21

INTERNATIONAL SEARCH REPORT

International application No
PCT/US2016/052984

A. CLASSIFICATION OF SUBJECT MATTER

INV. A61B18/14 A61B18/12 A61B17/32
ADD. A61B18/00 A61B90/00

According to International Patent Classification (IPC) or to both national classification and IPC

B. FIELDS SEARCHED

Minimum documentation searched (classification system followed by classification symbols)
A61B

Documentation searched other than minimum documentation to the extent that such documents are included in the fields searched

Electronic data base consulted during the international search (name of data base and, where practicable, search terms used)

EPO-Internal, WPI Data

C. DOCUMENTS CONSIDERED TO BE RELEVANT

Category*	Citation of document, with indication, where appropriate, of the relevant passages	Relevant to claim No.
X	US 2015/141981 A1 (PRICE DANIEL W [US] ET AL) 21 May 2015 (2015-05-21) paragraphs [0034] - [0037], [0040], [0042], [0045], [0047], [0048], [0050]; figures 1-12; table 1 -----	14-20
A	US 2009/254080 A1 (HONDA SATOSHI [JP]) 8 October 2009 (2009-10-08) paragraphs [0002], [0024], [0025], [0033]; figures 1-11 -----	14-20
A	WO 2011/008672 A2 (ETHICON ENDO SURGERY INC [US]; WEINER EITAN T [US]; WAN SHAN [US]; PRI) 20 January 2011 (2011-01-20) paragraphs [0008], [0039], [0051], [0055], [0079], [0098]; figures 1-20 -----	14-20

Further documents are listed in the continuation of Box C.

See patent family annex.

* Special categories of cited documents :

- "A" document defining the general state of the art which is not considered to be of particular relevance
- "E" earlier application or patent but published on or after the international filing date
- "L" document which may throw doubts on priority claim(s) or which is cited to establish the publication date of another citation or other special reason (as specified)
- "O" document referring to an oral disclosure, use, exhibition or other means
- "P" document published prior to the international filing date but later than the priority date claimed

"T" later document published after the international filing date or priority date and not in conflict with the application but cited to understand the principle or theory underlying the invention

"X" document of particular relevance; the claimed invention cannot be considered novel or cannot be considered to involve an inventive step when the document is taken alone

"Y" document of particular relevance; the claimed invention cannot be considered to involve an inventive step when the document is combined with one or more other such documents, such combination being obvious to a person skilled in the art

"&" document member of the same patent family

Date of the actual completion of the international search

14 December 2016

Date of mailing of the international search report

22/12/2016

Name and mailing address of the ISA/

European Patent Office, P.B. 5818 Patentlaan 2
NL - 2280 HV Rijswijk
Tel. (+31-70) 340-2040,
Fax: (+31-70) 340-3016

Authorized officer

Viidebaum, Mikk

INTERNATIONAL SEARCH REPORT

International application No.
PCT/US2016/052984

Box No. II Observations where certain claims were found unsearchable (Continuation of item 2 of first sheet)

This international search report has not been established in respect of certain claims under Article 17(2)(a) for the following reasons:

1. Claims Nos.: **1-13**
because they relate to subject matter not required to be searched by this Authority, namely:
see FURTHER INFORMATION sheet PCT/ISA/210

2. Claims Nos.:
because they relate to parts of the international application that do not comply with the prescribed requirements to such an extent that no meaningful international search can be carried out, specifically:

3. Claims Nos.:
because they are dependent claims and are not drafted in accordance with the second and third sentences of Rule 6.4(a).

Box No. III Observations where unity of invention is lacking (Continuation of item 3 of first sheet)

This International Searching Authority found multiple inventions in this international application, as follows:

1. As all required additional search fees were timely paid by the applicant, this international search report covers all searchable claims.

2. As all searchable claims could be searched without effort justifying an additional fees, this Authority did not invite payment of additional fees.

3. As only some of the required additional search fees were timely paid by the applicant, this international search report covers only those claims for which fees were paid, specifically claims Nos.:

4. No required additional search fees were timely paid by the applicant. Consequently, this international search report is restricted to the invention first mentioned in the claims; it is covered by claims Nos.:

Remark on Protest

- The additional search fees were accompanied by the applicant's protest and, where applicable, the payment of a protest fee.
- The additional search fees were accompanied by the applicant's protest but the applicable protest fee was not paid within the time limit specified in the invitation.
- No protest accompanied the payment of additional search fees.

FURTHER INFORMATION CONTINUED FROM PCT/ISA/ 210

Continuation of Box II.1

Claims Nos.: 1-13

Claims 1-13 relate to a method for operating a surgical instrument comprising a step of selecting a mode of operation, wherein the selectable modes of operation apply energy to the tissue. Therefore the method is considered to relate to treatment of the human or animal body by surgery, which the International Searching Authority is not required to search in accordance with Rule 39.1(iv) PCT.

INTERNATIONAL SEARCH REPORT

Information on patent family members

International application No

PCT/US2016/052984

Patent document cited in search report	Publication date	Patent family member(s)	Publication date	
US 2015141981	A1	21-05-2015	CN 105764435 A	13-07-2016
			EP 3071129 A1	28-09-2016
			JP 2016537129 A	01-12-2016
			US 2015141981 A1	21-05-2015
			WO 2015077119 A1	28-05-2015

US 2009254080	A1	08-10-2009	JP 5178559 B2	10-04-2013
			JP 2009247887 A	29-10-2009
			US 2009254080 A1	08-10-2009

WO 2011008672	A2	20-01-2011	AU 2010273651 A1	02-02-2012
			CA 2768129 A1	20-01-2011
			CN 102497827 A	13-06-2012
			EP 2453813 A2	23-05-2012
			JP 5710610 B2	30-04-2015
			JP 2012533346 A	27-12-2012
			WO 2011008672 A2	20-01-2011
