



(11) **EP 3 201 468 B1**

(12) **EUROPEAN PATENT SPECIFICATION**

(45) Date of publication and mention of the grant of the patent:
26.08.2020 Bulletin 2020/35

(21) Application number: **15847057.5**

(22) Date of filing: **25.09.2015**

(51) Int Cl.:
F04B 39/12^(2006.01) F04B 39/02^(2006.01)

(86) International application number:
PCT/CN2015/090720

(87) International publication number:
WO 2016/050174 (07.04.2016 Gazette 2016/14)

(54) **REFRIGERATION COMPRESSOR AND LIMITING DEVICE**

KÜHLKOMPRESSOR UND BEGRENZUNGSVORRICHTUNG

COMPRESSEUR DE RÉFRIGÉRATION ET DISPOSITIF DE LIMITATION

(84) Designated Contracting States:
AL AT BE BG CH CY CZ DE DK EE ES FI FR GB GR HR HU IE IS IT LI LT LU LV MC MK MT NL NO PL PT RO RS SE SI SK SM TR

(30) Priority: **30.09.2014 CN 201420580968 U**

(43) Date of publication of application:
09.08.2017 Bulletin 2017/32

(73) Proprietor: **Secop Compressors (Tianjin) Co., Ltd. Tianjin 301700 (CN)**

(72) Inventor: **WANG, Shuai Tianjin 300131 (CN)**

(74) Representative: **KLIMENT & HENHAPEL Patentanwälte OG Gonzagagasse 15/2 1010 Wien (AT)**

(56) References cited:
CN-U- 201 763 570 CN-U- 201 763 570
CN-U- 202 017 599 CN-U- 204 327 448
FR-A1- 2 581 132 FR-A7- 2 161 727
JP-A- H05 164 047 KR-A- 20070 075 914
SU-A1- 1 760 164 US-A- 3 385 542
US-A- 3 572 975 US-A- 4 174 189
US-A- 4 352 642

EP 3 201 468 B1

Note: Within nine months of the publication of the mention of the grant of the European patent in the European Patent Bulletin, any person may give notice to the European Patent Office of opposition to that patent, in accordance with the Implementing Regulations. Notice of opposition shall not be deemed to have been filed until the opposition fee has been paid. (Art. 99(1) European Patent Convention).

Description

FIELD OF THE INVENTION

[0001] The invention relates to a refrigeration compressor, in particular to a sealed refrigeration compressor with a piston structure and a limiting device for the refrigeration compressor.

BACKGROUND OF THE INVENTION

[0002] Traditional sealed piston compressor is widely used for a refrigerator, a freezer comprising a compressor unit mounted in a sealed space formed by an upper housing and a lower housing, a motor and a bracket for fixing the compressor unit and the motor. Generally, the whole assembly of the compressor unit, the motor and the bracket is referred to a pump body. The pump is elastically supported by several supporting springs arranged at the bottom of the lower housing. This way of elastic support can avoid a direct collision between the pump body and the housing when the compressor works, thereby reducing vibration and noise. Generally, this traditional compressor is used in static environment, such as a household refrigerator, a freezer which has relatively steady working environment.

[0003] With the continuous expansion of the refrigeration field, compressor is applied more and more widely, great changes have taken place in working environment of compressor, this traditional compressor used in static environment is also widely used in the movement environment of large bumps, vibrations, such as vehicle-mounted refrigerator, small-sized portable refrigeration equipment in medical field and the like. At the same time, there is not a stable environment in the process of transportation and installation of the compressor. In the prior art, if this kind of compressor is used in the movement environment, the pump body will be easy to separate from the elastic support, resulting in the failure of the spring.

SUMMARY OF THE INVENTION

[0004] The technical problem solved by the invention is to provide a refrigeration compressor and a limiting device for the refrigeration compressor, ensuring that the limiting device is smoothly mounted on an inner wall of a lower housing of the refrigeration compressor so as to prevent excessive inclination of the pump body caused by moving upward.

[0005] According to an embodiment of an aspect of the invention it provides a refrigeration compressor comprising:

an upper housing and a lower housing which are combined to form a containing space; at least one guide post which is positioned within the lower housing and over which a supporting spring is fitted; a

pump body arranged in the containing space and supported by the supporting spring. Such a refrigeration compressor is known from CN 201 763 570 U. However, the refrigeration compressor according to the invention further comprises at least one limiting Device which is different from the limiting device disclosed in CN 201 763 570 U. The limiting device according to the invention comprises:

a mounting portion mounted on an inner wall of the lower housing;

a stepped portion connected to an upper end of the mounting portion and protruding towards the direction away from the inner wall of the lower housing relative to a surface of the mounting portion; and

a limiting portion extending obliquely from the stepped portion to a position above a portion of the pump body so as to block upward movement of the pump body.

[0006] In an embodiment, the lower housing and the upper housing form an annular protrusion protruding towards the inner of the containing space at their joining portion; the protrusion is formed by a lower edge of the upper housing which is contained in the lower housing.

[0007] In an embodiment, when the height of stator lamination is increased, the protrusion is located in a gap between the stepped portion and the lower housing.

[0008] In an embodiment, the limiting portion extends from a side portion of the stepped portion to a position above a portion of the pump body and forms a certain angle with the stepped portion.

[0009] In an embodiment, the height of the position, at which the mounting portion is attached to the inner wall of the lower housing, is adjustable.

[0010] In an embodiment, the mounting portion is provided with at least one welding spot, the mounting portion is welded on the inner wall of the lower housing through at least one said welding spot.

[0011] In an embodiment, the pump body comprises a compressor assembly integrally assembled, a motor assembly for driving the compressor assembly, and a bracket for supporting the compressor assembly and the motor assembly, the motor assembly includes a rotor and a stator, the stator includes a stator lamination, wherein the limiting device of the pump body extends to above an upper surface of the stator lamination.

[0012] In an embodiment, the height of the stator lamination of the motor assembly varies with different requirements of the motor performance.

[0013] In an embodiment, two said limiting devices are symmetrically provided on the inner side wall of the lower housing.

[0014] According to an embodiment of the further aspect of the invention, it provides a limiting device for an refrigeration compressor, comprising: a mounting portion for attaching the limiting device to an inner wall of the lower housing of the refrigeration compressor; a stepped portion connected to an upper end of the mounting por-

tion and protruding towards one side relative to a surface of the mounting portion; and a limiting portion extending from a side portion of the stepped portion and inclined at an angle with respect to the stepped portion.

[0015] In an embodiment, the mounting portion is provided with at least one welding spot through which the limiting device is attached to the inner wall of the lower housing of the refrigeration compressor.

[0016] In an embodiment, the mounting portion, the stepped portion and the limiting portion of the limiting device are integral.

[0017] According to the refrigeration compressor and the limiting device of above -mentioned embodiments of the invention, the limiting device is provided with the stepped portion so that a space formed between the stepped portion and the lower housing may contain the protrusion formed at the joining portion of the upper housing and the lower housing, while keeping the mounting portion stably arranged on the inner wall of the lower housing. When the pump body moves upward, an upper surface of a portion of the pump body will contact against the lower portion of the limiting portion of the limiting device, therefore the whole pump body cannot continue to move upward, preventing excessive inclination of the pump body caused by moving upward.

BRIEF DESCRIPTION OF THE ACCOMPANYING DRAWINGS

[0018] The present invention will be further described in detail with reference to the appended figures and embodiments.

FIG. 1 is a top view of a refrigeration compressor according to an exemplary embodiment of the invention, without showing an upper housing;

FIG. 2 is a schematic perspective view of a lower housing of a refrigeration compressor according to an exemplary embodiment of the invention, a limiting device is shown;

FIG. 3 is a schematic perspective view of a limiting device shown in FIG. 2; and

FIG. 4 is a diagram of installation state of a limiting device according to an embodiment of the invention.

DETAILED DESCRIPTION OF THE PREFERRED EMBODIMENTS

[0019] Embodiments of the present invention will be described in detail, and examples of the embodiments are shown in the figures, wherein the throughout same or similar reference numerals denote same or similar elements or elements with same or similar functions. The following embodiments described referring to the appended figures are just exemplary, which is only used for explaining the invention, thus can not be understood as limited to the invention.

[0020] Furthermore, in the following detailed descrip-

tion, in order to facilitate explanation, many specific details are elaborated to fully understand the embodiments. However, obviously, one or more embodiments also can be implemented in the absence of these details. In other cases, well-known structures and devices are embodied by the way of illustration to simplify the figures.

[0021] Reference is made to FIGS 1 to 4, a refrigeration compressor 100 according to an exemplary embodiment of the invention comprises: an upper housing 1, a lower housing 2, a guide post 3, a pump body and at least one limiting device 5. The upper housing 1 and the lower housing 2 are combined to form a containing space, and the upper housing 1 and the lower housing form an annular protrusion 11 protruding towards the containing space at a joining position. There may be a plurality of the guide posts 3, and the plurality of the guide posts can be symmetrically arranged within the lower housing 2, and a supporting spring (not shown) is fitted over each guide post 3. The pump body is arranged in the containing space and supported by the supporting spring. The limiting device 5 is integrally formed by, for example, stainless steel sheet. The limiting device 5 comprises a mounting portion 51, a stepped portion 52 and a limiting portion 53. The mounting portion 51 is mounted on an inner wall of the lower housing 2. The stepped portion 52 is connected to an upper end of the mounting portion 51, and the stepped portion 52 offsets away from a side of the lower housing 2 along an upper end of the mounting portion 51, so that a containing space is formed between the stepped portion 52 and the inner wall of the lower housing 2, when the limiting device 5 is mounted on the inner wall of the lower housing 2. The limiting portion 53 extends from the stepped portion 51 to a position above a stator 43 which is one of components of the pump body so as to block upward movement of the pump body.

[0022] In an exemplary embodiment, referring to FIG. 1, the pump body 4 comprises a compressor assembly 41 integrally assembled, a motor assembly for driving the compressor assembly 41, and a bracket for supporting the compressor assembly 41 and the motor assembly 42. The motor assembly includes a rotor 42 and a stator 43. The stator includes a stator lamination, wherein the limiting device 5 of the pump body extends to a position above an upper surface of the stator lamination. Wherein, since the specific structure of the compressor assembly 41 is identical to the prior art, it will not be reiterated here.

[0023] In an exemplary embodiment, four guide posts 3 are symmetrically arranged on the inner wall of the bottom of the lower housing 2. One end of the supporting spring is fitted over the guide post 3, and the other end of the supporting spring is fitted over a boss (not shown) located at the bottom of the pump body, therefore, the pump body is resiliently supported in the sealed containing space within the compressor 100. The stator core laminations are formed by stacking simultaneously molded and punched metal sheets. A stator winding is fixed on the periphery of stator core laminations. The upper surface of the stator core laminations is a substantially

flat surface, above which there is a space in sealed containing space.

[0024] Reference is made to FIG. 4, the protrusion 11 is formed by a lower edge of the upper housing 1 which is contained within an upper edge 21 of the lower housing 2. The upper housing 1 and the lower housing 2 are combined by, such as, welding, and the lower edge of the upper housing 1 protrudes inwardly inside the lower housing 2 to form an annular protrusion 11. Accordingly, the stepped portion 52 of the limiting device 5 is formed through inwardly, substantially perpendicular bent for two times relative to the mounting portion 51 so as to match with the shape of the protrusion 11.

[0025] At present, the development trend of refrigeration compressor increasingly concentrates on the compact structure and more miniaturized volume, while still maintaining the rated refrigerating capacity, that is to say, the size of the entire housing is kept unchanged, while refrigeration capacity is becoming larger. Also, one direction of research and development is optimizing the height of the stator core laminations of the motor assembly with unchanged overall size of the housing. When the refrigeration compressor has higher efficiency and higher refrigeration capacity, the structure of the motor assembly need to be changed, such as increasing the height of the stator core laminations, to improve output torque of the motor assembly.

[0026] In an exemplary embodiment, the limiting device 5 has a generally approximate inverted "L" shape in the plane view and is provided with the stepped portion 52 deviated relative to the surface of the mounting portion 51. The limiting portion 53 extends obliquely to a position above a portion 43 of the pump body from side portion of the stepped portion 52. In this way, as shown in FIG. 4, a containing space formed between the stepped portion 52 and the inner wall of the lower housing 2 can be used for accommodating the protrusion 11, thus, the length of the mounting portion 51 of the limiting device 5 may be changed such that it may still be installed on flat portion of the inner wall of the lower housing 2 in case that the height of the stator core laminations is substantially flush with the protrusion, at the same time, the limiting portion 53 can still be located above the stator laminations. When the pump body moves upward, an upper surface of a portion 43 of the pump body will contact against the lower portion of the limiting portion 53 of the limiting device 5, therefore the whole pump body 4 cannot continue to move upward. Thus, the limiting device of the invention can be used to prevent excessive inclination of the pump body 4 caused by moving upward, which makes the detachment of the pump body from supporting spring, thus resulting in the failure of the compressor.

[0027] A limited portion 43 of the pump body is a relatively static and substantially flat upper surface during operation of the compressor, and there is an appropriate space within the sealed space of the inner of the compressor above the upper surface, in which the limiting device 5 can be arranged to block upward movement of

the pump body. A portion 43 limited by the limiting portion 53 may be an upper surface of the pump component, such as stator core laminations, because the stator core laminations have appropriate plane area and flatness.

Of course, a portion limited by the limiting portion 53 also may be stator bracket, groove, hole and the like of the pump component.

[0028] In an embodiment, the limiting device 5 and a portion of the pump body are spaced apart with a predetermined gap in the up-down direction. Therefore, the limiting device 5 is arranged above upper surface of a portion 43 of the pump body and does not contact with each other. In this way, this will not produce friction during normal operation of the compressor, thereby there will not produce wear or noise. It should be noted that direct contact or pressing between the limiting device 5 and one portion of the pump body can also realize the restriction to upward movement of the pump body.

[0029] In the above embodiment, the protrusion 11 is formed by the lower edge of the upper housing 1 which is contained in the lower housing 2, and the stepped portion 52 of the limiting device 5 is formed through inwardly, substantially perpendicular bent for two times relative to the mounting portion 51. In another exemplary embodiment, the protrusion 11 is formed by an upper edge of the lower housing 2 which is contained in the upper housing, and the stepped portion of the limiting device is formed through outwardly, substantially perpendicular bent for two times relative to the mounting portion, such that there is a containing space between the stepped portion 53 and the lower housing 2 to contain an edge portion of the upper housing 1 installed on the lower housing 2.

[0030] In an exemplary embodiment, the mounting portion 51 is mounted on the inner wall of the lower housing 2 with the height being adjustable. For example, the mounting portion 51 is provided with at least one welding spot 55. Thus, the mounting portion 51 can be installed at different height by selecting the welding spot 55 so as to adapt to different height of the stator core laminations, and to ensure that a containing space can be formed between the stepped portion 52 and the inner wall of the lower housing 2 to contain the protrusion 11.

[0031] According to an exemplary embodiment of the refrigeration compressor 100 of the present invention, the motor assembly is replaceable, and the different stator core laminations of the motor assembly have different height. In this way, if the refrigeration capacity of the refrigeration compressor 100 need to be changed, the stator core laminations with different height can be replaced so as to the motor assembly has different output power, correspondingly, changing the mounting height of the limiting device. Furthermore, two or more limiting device can be symmetrically arranged on the inner wall of the lower housing such that the pump 4 can be uniformly forced and not incline.

[0032] As shown in FIG. 3, according to another aspect of embodiments of the present invention, it provides a

limiting device 5 for a refrigeration compressor 100, comprising: a mounting portion 51, a stepped portion 52 and a limiting portion 53. The mounting portion 51 is mounted on an inner wall of a lower housing 2 of the refrigeration compressor 100. The stepped portion 52 is connected to an upper end of the mounting portion 51 and protrudes towards one side relative to a surface of the mounting portion 51. The limiting portion extends obliquely from the side portion of the stepped portion 52. And the mounting portion 51 is provided with at least one welding spot 55 to adjust mounting height of the limiting device 5.

[0033] The limiting device 5 has a generally inverted "L" shape in the plane view, and the limiting portion 53 forms a stopper structure extending from side portion of the stepped portion 52. When the limiting device 5 is mounted to the inner wall of the lower housing 2 through the mounting portion 51, the stepped portion 52 is located in the direction away from the inner side wall of the lower housing 2, and the limiting portion 53 is located above a portion (such as stator core lamination) of the pump body, blocking the upward movement of the whole pump body.

[0034] According to the refrigeration compressor and the limit device of above -mentioned embodiments of the invention, because the stepped portion is arranged on the limiting device, such that a containing space can be formed between the stepped portion and the inner wall of the lower housing, therefore, the mounting portion is steadily mounted on the inner wall of the lower housing, and when the height of the pump increases (such as 5mm), due to the stepped portion, the limiting device will not hinder the installation of the upper housing on the lower housing. When the pump moves upward, an upper surface of a portion of the pump will contact against the lower portion of the limiting portion of the limiting device, therefore the whole pump body cannot continue to move upward. Thus, this can prevent excessive inclination of the pump body caused by moving upward which makes the detachment of the pump body from supporting spring, resulting in the failure of the compressor.

[0035] Furthermore, the height of the limiting device according to the embodiment of the invention is adjustable, therefore it can adapt to the stator core laminations with different height and allow the replacement of the motor assembly with different power, so that the refrigeration compressor has a different refrigerating capacity, and at the same time the volume of the entire housing does not need to be changed.

[0036] It should be understood by those skilled in the art that the above-mentioned embodiments are exemplary and can be improved, the structures described in various embodiments can be freely combined in the case of no conflict of structures or principles, so that more refrigeration compressors and limiting devices can be realized on the basis of solving the technical problems of the invention.

[0037] While embodiments of the invention have been shown and described, it should be understood by those skilled in the art that various changes, modifications, re-

placements and variations can be made in the present invention.

5 Claims

1. A refrigeration compressor (100), comprising:

an upper housing (1) and a lower housing (2) which are combined to form a containing space; at least one guide post (3) arranged within the lower housing (2),
a supporting spring being fitted over the at least one guide post (3);
a pump body arranged in the containing space and supported by the supporting spring; and
at least one limiting device (5) comprising:

a mounting portion (51) mounted on an inner wall of the lower housing (2);
a stepped portion (52) connected to an upper end of the mounting portion (51) and protruding towards a direction away from the inner wall of the lower housing (2) relative to a surface of the mounting portion (51); whereas the refrigeration compressor (100) is **characterized in that** the limiting device (5) further comprises
a limiting portion (53) extending obliquely from the stepped portion (52) to a position above a portion (43) of the pump body so as to block upward movement of the pump body.

2. The refrigerant compressor (100) according to claim 1, **characterized in that** the limiting portion (53) is adapted to block upward movement of the pump body upon contact of a lower portion of the limiting portion (53) with an upper surface of said portion (43) of the pump body.

3. The refrigeration compressor (100) according to claim 1, **characterized in that** the lower housing (2) and the upper housing (1) form, at their joining portion, an annular protrusion (11) protruding towards the containing space;
the annular protrusion (11) is formed by a lower edge of the upper housing (1) which is contained in the lower housing (2).

4. The refrigeration compressor (100) according to claim 3, **characterized in that** when the height of a stator lamination increases, the annular protrusion (11) is located at a gap between the stepped portion (52) and the lower housing (2).

5. The refrigeration compressor (100) according to claim 1, **characterized in that** the limiting portion

(53) extends from a side of the stepped portion (52) to the position above the portion (43) of the pump body and forms an angle with the stepped portion (52).

6. The refrigeration compressor (100) according to any one of claims 1, 3, 4, or 5, **characterized in that** the mounting portion (51) is provided with at least one welding spot (55) enabling the mounting portion (51) to be installed at different height by selecting the welding spot (55).
7. The refrigeration compressor (100) according to claim 6, **characterized in that** the mounting portion (51) is welded to the inner wall of the lower housing (2) via the at least one welding spot (55).
8. The refrigeration compressor (100) according to claim 6, **characterized in that** the pump body comprises a compressor assembly (41) assembled integrally, a motor assembly for driving the compressor assembly (41), and an bracket for supporting the compressor assembly (41) and the motor assembly, the motor assembly comprises a rotor (42) and a stator (43), the stator (43) comprises a stator lamination, wherein the limiting device (5) of the pump body extends to a position above an upper surface of the stator lamination.
9. The refrigeration compressor (100) according to claim 8, **characterized in that** the height of the stator lamination of the motor assembly varies with the different requirements of the motor performance.
10. The refrigeration compressor (100) according to claim 5, **characterized in that** two limiting devices (5) are symmetrically provided on the inner wall of the lower housing (2).

Patentansprüche

1. Kühlkompressor (100), umfassend:

ein oberes Gehäuse (1) und ein unteres Gehäuse (2), die kombiniert sind, um einen Aufnahme-
raum zu bilden;
wenigstens einen Führungsstift (3), der im Innen-
ren des unteren Gehäuses (2) angeordnet ist,
eine Tragfeder, die auf den wenigstens einen
Führungsstift (3) aufgesetzt ist;
einen Pumpenkörper, der in dem Aufnahme-
raum angeordnet ist und durch die Tragfeder
getragen wird; und
wenigstens eine Begrenzungsvorrichtung (5),
umfassend:

einen Montageabschnitt (51), der an einer

Innenwand des unteren Gehäuses (2) mon-
tiert ist;

einen abgestuften Abschnitt (52), der mit ei-
nem oberen Ende des Montageabschnitts
(51) verbunden ist und in einer Richtung
weg von der Innenwand des unteren Ge-
häuses (2) relativ zu einer Oberfläche des
Montageabschnitts (51) vorspringt; wobei
der Kühlkompressor (100) **dadurch ge-
kennzeichnet ist, dass** die Begrenzungsvor-
richtung (5) ferner einen Begrenzungsvor-
abschnitt (53) umfasst, der sich schräg von
dem abgestuften Abschnitt (52) zu einer Po-
sition über einem Abschnitt (43) des Pum-
penkörpers erstreckt, sodass die Aufwärts-
bewegung des Pumpenkörpers blockiert
wird.

2. Kühlkompressor (100) nach Anspruch 1, **dadurch gekennzeichnet, dass** der Begrenzungsvorabschnitt (53) dafür eingerichtet ist, die Aufwärtsbewegung des Pumpenkörpers bei Kontakt eines unteren Abschnitts des Begrenzungsvorabschnitts (53) mit einer oberen Oberfläche des Abschnitts (43) des Pumpenkörpers zu blockieren.
3. Kühlkompressor (100) nach Anspruch 1, **dadurch gekennzeichnet, dass** das untere Gehäuse (2) und das obere Gehäuse (1) an ihrem Verbindungsabschnitt einen ringförmigen Vorsprung (11) bilden, der zu dem Aufnahme-
raum hin vorspringt;
wobei der ringförmige Vorsprung (11) durch eine untere Kante des oberen Gehäuses (1) gebildet wird, die in dem unteren Gehäuse (2) aufgenommen ist.
4. Kühlkompressor (100) nach Anspruch 3, **dadurch gekennzeichnet, dass**, wenn die Höhe einer Statorblechung zunimmt, sich der ringförmige Vorsprung (11) an einem Spalt zwischen dem abgestuften Abschnitt (52) und dem unteren Gehäuse (2) befindet.
5. Kühlkompressor (100) nach Anspruch 1, **dadurch gekennzeichnet, dass** sich der Begrenzungsvorabschnitt (53) von einer Seite des abgestuften Abschnitts (52) zu der Position über dem Abschnitt (43) des Pumpenkörpers erstreckt und einen Winkel mit dem abgestuften Abschnitt (52) bildet.
6. Kühlkompressor (100) nach einem der Ansprüche 1, 3, 4 oder 5, **dadurch gekennzeichnet, dass** der Montageabschnitt (51) mit wenigstens einem Schweißpunkt (55) versehen ist, der es ermöglicht, den Montageabschnitt (51) in unterschiedlicher Höhe einzubauen, indem der Schweißpunkt (55) ausgewählt wird.
7. Kühlkompressor (100) nach Anspruch 6, **dadurch**

gekennzeichnet, dass der Montageabschnitt (51) durch den wenigstens einen Schweißpunkt (55) an die Innenwand des unteren Gehäuses (2) geschweißt wird.

8. Kühlkompressor (100) nach Anspruch 6, **dadurch gekennzeichnet, dass** der Pumpenkörper eine einstückig zusammengesetzte Kompressoranordnung (41), eine Motoranordnung zum Antreiben der Kompressoranordnung (41) und eine Halterung zum Tragen der Kompressoranordnung (41) und der Motoranordnung umfasst, die Motoranordnung einen Rotor (42) und einen Stator (43) umfasst und der Stator (43) eine Statorblechung umfasst, wobei sich die Begrenzungsvorrichtung (5) des Pumpenkörpers zu einer Position über einer oberen Oberfläche der Statorblechung erstreckt.
9. Kühlkompressor (100) nach Anspruch 8, **dadurch gekennzeichnet, dass** die Höhe der Statorblechung der Motoranordnung mit den unterschiedlichen Anforderungen der Motorleistung variiert.
10. Kühlkompressor (100) nach Anspruch 5, **dadurch gekennzeichnet, dass** zwei Begrenzungsvorrichtungen (5) symmetrisch an der Innenwand des unteren Gehäuses (2) vorgesehen sind.

Revendications

1. Compresseur de réfrigération (100), comprenant :

un logement supérieur (1) et un logement inférieur (2) qui sont combinés pour former un espace de confinement ;
 au moins un montant de guidage (3) agencé au sein du logement inférieur (2),
 un ressort de support qui est adapté sur l'au moins un montant de guidage (3) ;
 un corps de pompe agencé dans l'espace de confinement et supporté par le ressort de support ; et
 au moins un dispositif de limitation (5) comprenant :

une portion de montage (51) montée sur une paroi interne du logement inférieur (2) ;
 une portion étagée (52) raccordée à une extrémité supérieure de la portion de montage (51) et faisant saillie vers une direction en éloignement de la paroi interne du logement inférieur (2) par rapport à une surface de la portion de montage (51) ; tandis que le compresseur de réfrigération (100) est **caractérisé en ce que** le dispositif de limitation (5) comprend en outre une portion de limitation (53) s'étendant à

l'oblique depuis la portion étagée (52) jusqu'à une position au-dessus d'une portion (43) du corps de pompe de façon à bloquer un déplacement vers le haut du corps de pompe.

5

2. Compresseur de réfrigération (100) selon la revendication 1, **caractérisé en ce que** la portion de limitation (53) est adaptée pour bloquer un déplacement vers le haut du corps de pompe lors d'un contact d'une portion inférieure de la portion de limitation (53) avec une surface supérieure de ladite portion (43) du corps de pompe.

10

3. Compresseur de réfrigération (100) selon la revendication 1, **caractérisé en ce que** le logement inférieur (2) et le logement supérieur (1) forment, au niveau de leur portion de jonction, une saillie annulaire (11) faisant saillie vers l'espace de confinement ; la saillie annulaire (11) est formée par un bord inférieur du logement supérieur (1) qui est contenu dans le logement inférieur (2).

15

20

4. Compresseur de réfrigération (100) selon la revendication 3, **caractérisé en ce que** lorsque la hauteur d'un paquet de tôles de stator augmente, la saillie annulaire (11) est située au niveau d'un écartement entre la portion étagée (52) et le logement inférieur (2).

25

30

5. Compresseur de réfrigération (100) selon la revendication 1, **caractérisé en ce que** la portion de limitation (53) s'étend depuis un côté de la portion étagée (52) jusqu'à la position au-dessus de la portion (43) du corps de pompe et forme un angle avec la portion étagée (52).

35

6. Compresseur de réfrigération (100) selon l'une quelconque des revendications 1, 3, 4, ou 5, **caractérisé en ce que** la portion de montage (51) est pourvue d'au moins un point de soudure (55) permettant d'installer la portion de montage (51) à une hauteur différente en sélectionnant le point de soudure (55).

40

7. Compresseur de réfrigération (100) selon la revendication 6, **caractérisé en ce que** la portion de montage (51) est soudée à la paroi interne du logement inférieur (2) via l'au moins un point de soudure (55).

45

8. Compresseur de réfrigération (100) selon la revendication 6, **caractérisé en ce que** le corps de pompe comprend un ensemble compresseur (41) assemblé d'un seul tenant, un ensemble moteur pour entraîner l'ensemble compresseur (41), et une potence pour supporter l'ensemble compresseur (41) et l'ensemble moteur, l'ensemble moteur comprend un rotor (42) et un stator (43), le stator (43) comprend un paquet de tôles de stator, dans lequel le dispositif

50

55

de limitation (5) du corps de pompe s'étend jusqu'à une position au-dessus d'une surface supérieure du paquet de tôles de stator.

9. Compresseur de réfrigération (100) selon la revendication 8, **caractérisé en ce que** la hauteur du paquet de tôles de stator de l'ensemble moteur varie avec les différentes exigences de la performance de moteur.
10. Compresseur de réfrigération (100) selon la revendication 5, **caractérisé en ce que** deux dispositifs de limitation (5) sont prévus symétriquement sur la paroi interne du logement inférieur (2).

5

10

20

25

30

35

40

45

50

55

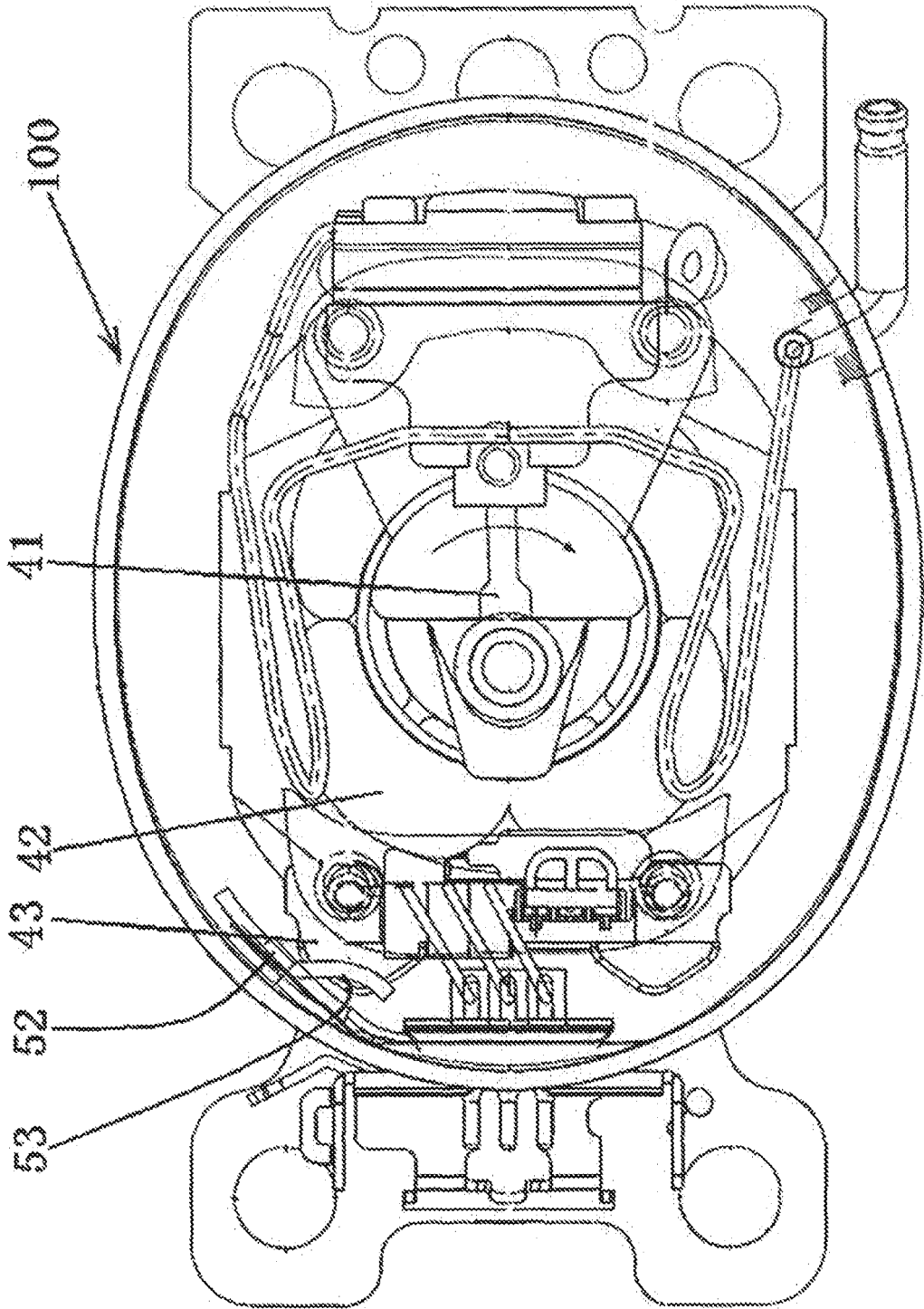

FIG. 1

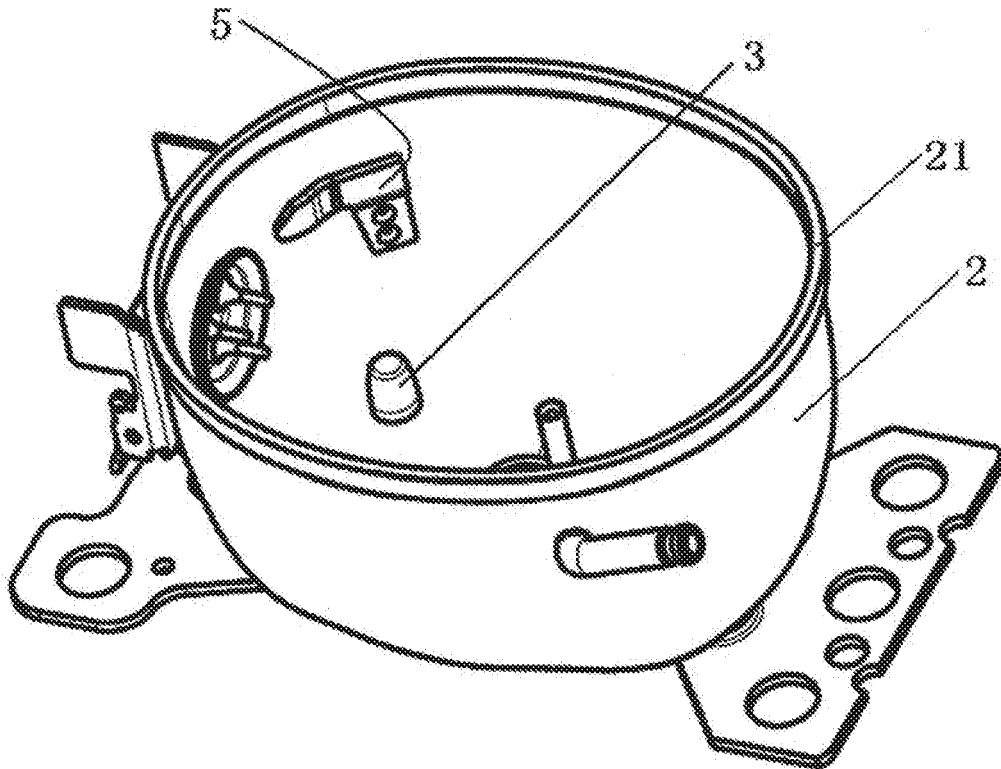

FIG. 2

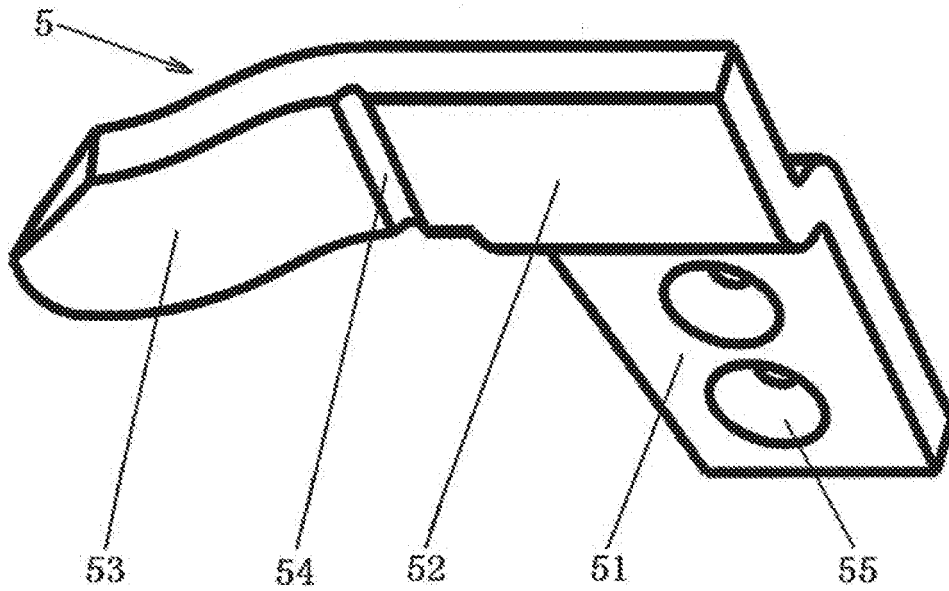

FIG. 3

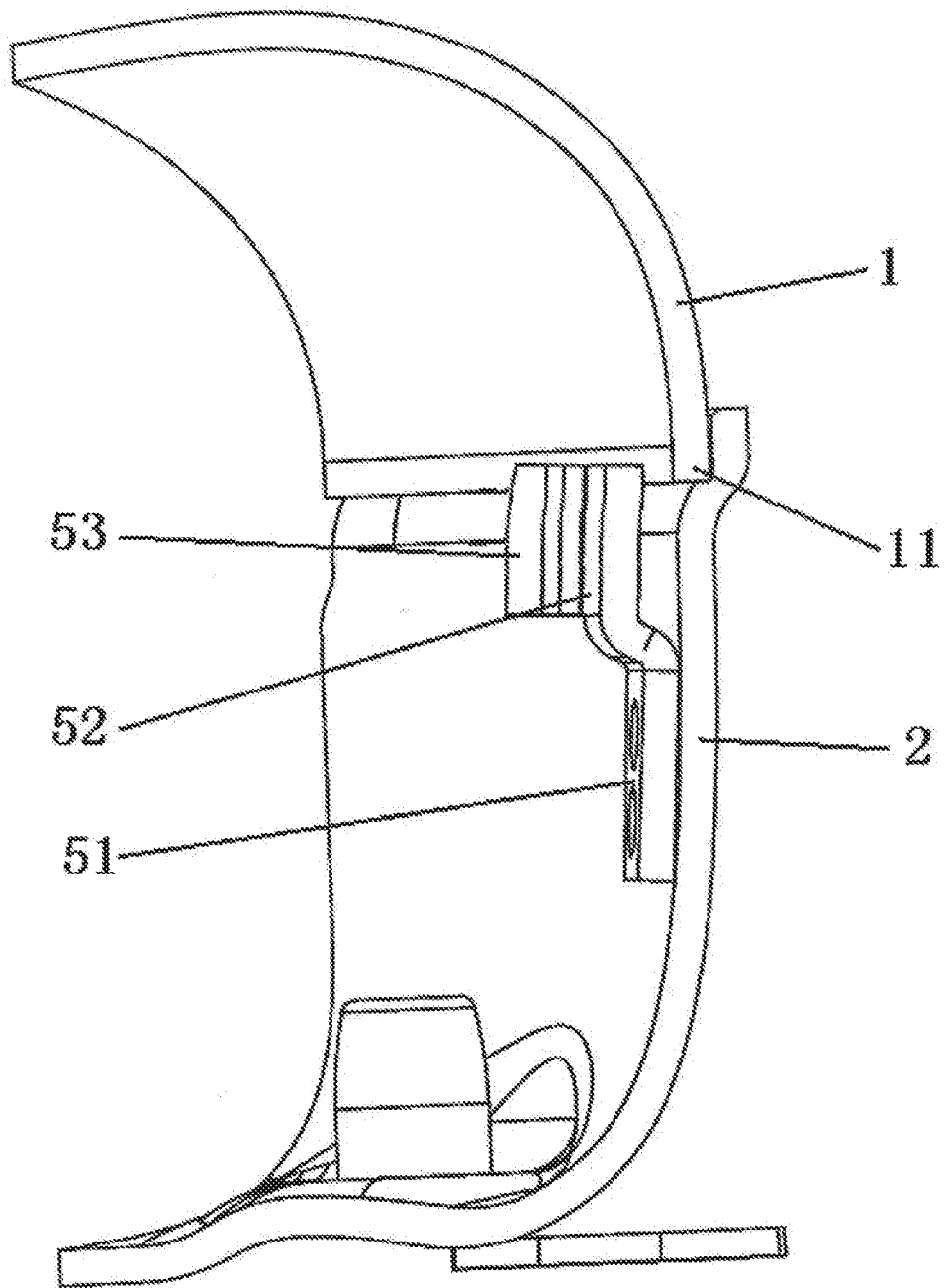

FIG. 4

REFERENCES CITED IN THE DESCRIPTION

This list of references cited by the applicant is for the reader's convenience only. It does not form part of the European patent document. Even though great care has been taken in compiling the references, errors or omissions cannot be excluded and the EPO disclaims all liability in this regard.

Patent documents cited in the description

- CN 201763570 U [0005]