



- (51) International Patent Classification: *F23D 14/72* (2006.01)
- (21) International Application Number: PCT/US2015/015057
- (22) International Filing Date: 9 February 2015 (09.02.2015)
- (25) Filing Language: English
- (26) Publication Language: English
- (30) Priority Data:
  - PCT/US2014/016622 14 February 2014 (14.02.2014) US
  - PCT/US2014/016632 14 February 2014 (14.02.2014) US
- (71) Applicant: **CLEARSIGN COMBUSTION CORPORATION** [US/US]; 12870 Interurban Avenue South, Seattle, WA 98168 (US).
- (72) Inventor: **KARKOW, Douglas, Wayne**; 1656 S 261st Place, Des Moines, WA 98198 (US).
- (74) Agents: **SIMON, Marcus, S.** et al.; Dorsey & Whitney LLP, 136 South Main Street, Suite 1000, Salt Lake City, UT 84101-1685 (US).
- (81) Designated States (*unless otherwise indicated, for every kind of national protection available*): AE, AG, AL, AM, AO, AT, AU, AZ, BA, BB, BG, BH, BN, BR, BW, BY, BZ, CA, CH, CL, CN, CO, CR, CU, CZ, DE, DK, DM, DO, DZ, EC, EE, EG, ES, FI, GB, GD, GE, GH, GM, GT, HN, HR, HU, ID, IL, IN, IR, IS, JP, KE, KG, KN, KP, KR, KZ, LA, LC, LK, LR, LS, LU, LY, MA, MD, ME, MG, MK, MN, MW, MX, MY, MZ, NA, NG, NI, NO, NZ, OM, PA, PE, PG, PH, PL, PT, QA, RO, RS, RU, RW, SA, SC, SD, SE, SG, SK, SL, SM, ST, SV, SY, TH, TJ, TM, TN, TR, TT, TZ, UA, UG, US, UZ, VC, VN, ZA, ZM, ZW.
- (84) Designated States (*unless otherwise indicated, for every kind of regional protection available*): ARIPO (BW, GH, GM, KE, LR, LS, MW, MZ, NA, RW, SD, SL, ST, SZ, TZ, UG, ZM, ZW), Eurasian (AM, AZ, BY, KG, KZ, RU, TJ, TM), European (AL, AT, BE, BG, CH, CY, CZ, DE, DK, EE, ES, FI, FR, GB, GR, HR, HU, IE, IS, IT, LT, LU, LV, MC, MK, MT, NL, NO, PL, PT, RO, RS, SE, SI, SK,

[Continued on next page]

(54) Title: BURNERS WITH FLAME CONTROL AND POSITIONING, AND RELATED METHODS

(57) Abstract: Embodiments disclosed herein include flame positioning and stabilization devices, systems, and methods as well as burners and combustion systems (e.g., systems that include multiple burners), which incorporate such flame positioning and stabilization devices, systems, and methods.

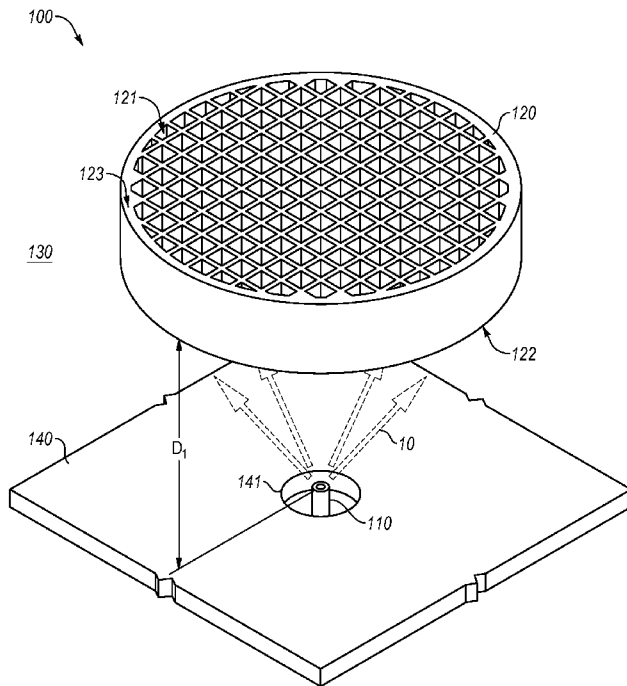

Fig. 1



SM, TR), OAPI (BF, BJ, CF, CG, CI, CM, GA, GN, GQ, GW, KM, ML, MR, NE, SN, TD, TG). **Published:**

— *without international search report and to be republished upon receipt of that report (Rule 48.2(g))*

## BURNERS WITH FLAME CONTROL AND POSITIONING, AND RELATED METHODS

### CROSS-REFERENCE TO RELATED APPLICATIONS

5 [0001] This application is a continuation-in-part (“CIP”) of PCT International Application No. PCT/US2014/016622 filed on 14 February 2014 and PCT International Application No. PCT/US2014/016632 filed on 14 February 2014. The disclosure of each of the foregoing applications is incorporated herein, in its entirety, by this reference.

### BACKGROUND

10

[0002] There are many different types of burners and combustion systems. Generally, a burner includes a fuel nozzle that injects or flows fuel that mixes with an oxidizer. After mixing with the oxidizer, the fuel is ignited and combusted to generate heat.

15

[0003] Some burners include a burner plate or flame holder positioned above a fuel nozzle. For instance, the fuel and oxidizer may be ignited or combusted at or near the flame holder. In any event, burners and combustion systems are used in a wide variety of applications that may require heat.

20

[0004] Therefore, developers and users of burners and combustion systems continue to seek improvements thereto.

### SUMMARY

25

[0005] Embodiments disclosed herein include flame positioning and stabilization devices, systems, and methods as well as burners and combustion systems (*e.g.*, systems that include multiple burners), which incorporate such flame positioning and stabilization devices, systems, and methods. For example, a flame may be produced during combustion of fuel and oxidizer mixture. The fuel may be supplied from or flow out of a fuel nozzle and the flame may be produced downstream from the nozzle. The flame positioning and stabilization system may stabilize the flame downstream from the nozzle in a manner that reduces, minimizes, or prevents flame blow-out (*e.g.*, when the speed of the fuel flow is relatively high and the flame speed is relatively low, the flame may blow off or may be extinguished by the draft or forces produced by fuel flow onto the flame). In other words, under some operating conditions, the flame from a conventional nozzle and/or in a conventional burner may be unstable and/or may blow off.

30

**[0006]** An embodiment includes a method of controlling a downstream position of a flame relative to a primary fuel nozzle. The method includes flowing a first fuel downstream from the primary fuel nozzle. The first fuel has a first flame speed. The method also includes mixing at least a portion of a second fuel flow with at least a portion  
5 of the first fuel. The second fuel has a second flame speed that is greater than the first flame speed. Furthermore, the method includes igniting one or more of at least a portion of the first fuel or at least a portion of the second fuel to produce the flame extending downstream from the primary fuel nozzle. Additionally, the method includes controlling the downstream position of the flame relative to the primary fuel nozzle including  
10 controlling a relative proportion of the second fuel mixed with the first fuel and/or by controlling a position of the second fuel flow relative to the primary fuel nozzle.

**[0007]** Embodiments also include a burner. The burner includes a perforated flame holder and one or more fuel nozzles spaced from the perforated burner plate. The one or more fuel nozzles include a primary nozzle facing generally toward the perforated  
15 burner holder. The burner also includes a first fuel source operably coupled to the primary fuel nozzle of the one or more fuel nozzles. The first fuel source includes a first fuel having a first flame speed. Moreover, the burner includes a second fuel source operably coupled to at least one of the one or more fuel nozzles. The second fuel source has a second flame speed that is greater than the first flame speed. In addition, the burner  
20 includes one or more control mechanisms configured to control a position of flow of the second fuel relative to the first fuel and/or a relative proportion of the first and second fuels flowing toward the perforated flame holder.

**[0008]** One or more embodiments include a burner that includes a perforated burner holder and a primary nozzle having a longitudinal axis and configured to flow a  
25 first fuel generally toward the perforated burner holder. The burner also includes a flame control mechanism configured to produce ignition of the first fuel at or near the perforated burner holder by igniting the first fuel in a manner that forms a flame at a first position relative to the perforated burner plate and changing the position of the flame to a second position, the second position being closer to the perforated burner plate than the  
30 first position.

**[0009]** Features from any of the disclosed embodiments may be used in combination with one another, without limitation. In addition, other features and advantages of the present disclosure will become apparent to those of ordinary skill in the

art through consideration of the following detailed description and the accompanying drawings.

### BRIEF DESCRIPTION OF THE DRAWINGS

5 [0010] The drawings illustrate several embodiments, wherein identical reference numerals refer to identical or similar elements or features in different views or embodiments shown in the drawings.

[0011] FIG. 1 is an isometric view of a burner including a perforated flame holder according to an embodiment;

10 [0012] FIG. 2A is a schematic cross-sectional view of a burner having a flame positioned at a first position according to an embodiment;

[0013] FIG. 2B is a schematic cross-sectional view of the burner of FIG. 2A having a flame positioned at a second position according to an embodiment;

[0014] FIG. 2C is a schematic cross-sectional view of the burner of FIG. 2A  
15 having a flame positioned at a third position according to an embodiment;

[0015] FIG. 3A is a schematic cross-sectional view of the burner of FIG. 2A having a flame positioned at a fourth position according to an embodiment;

[0016] FIG. 3B is a schematic cross-sectional view of the burner of FIG. 2A having a flame positioned at a fifth position according to an embodiment;

20 [0017] FIG. 3C is a schematic cross-sectional view of the burner of FIG. 2A having a flame positioned at a sixth position according to an embodiment;

[0018] FIG. 4A is a schematic cross-sectional view of a burner according to another embodiment having a flame positioned at a first position;

[0019] FIG. 4B is a schematic cross-sectional view of the burner of FIG. 4A  
25 having a flame positioned at a second position according to an embodiment;

[0020] FIG. 4C is a schematic cross-sectional view of the burner of FIG. 4A having a flame positioned at a third position according to an embodiment;

[0021] FIG. 5A is an isometric view of a flame holder according to an embodiment; and

30 [0022] FIG. 5B is a partial cross-sectional view of the flame holder of FIG. 5B.

### DETAILED DESCRIPTION

[0023] Embodiments disclosed herein include flame positioning and stabilization devices, systems, and methods as well as burners and combustion systems (*e.g.*, systems

that include multiple burners), which incorporate such flame positioning and stabilization devices, systems, and methods. For example, a flame may be produced during combustion of fuel and oxidizer mixture. The fuel may be supplied from or flow out of a fuel nozzle and the flame may be produced downstream from the nozzle. The flame  
5 positioning and stabilization system may stabilize the flame downstream from the nozzle in a manner that reduces, minimizes, or prevents flame blow-out (*e.g.*, when the speed of the fuel flow is relatively high and the flame speed is relatively low, the flame may blow off or may be extinguished by the draft or forces produced by fuel flow onto the flame). In other words, under some operating conditions, the flame from a conventional nozzle  
10 and/or in a conventional burner may be unstable and/or may blow off.

**[0024]** Generally, the “flame speed” is the speed at which the flame propagates upstream, against the flow of fuel from a location of ignition of the fuel. As such, the “flame speed” may vary from one fuel to another. Moreover, for the same fuel, the flame speed may vary depending on the temperature of the fuel, temperature of the oxidizer,  
15 temperature of the unburnt fuel, fuel pressure in a combustion chamber, velocity of fuel flow, combinations thereof, etc. Additionally, the flame speed may depend on the type of flow (*e.g.*, laminar or non-laminar flow).

**[0025]** In some embodiments, the flame positioning and stabilization system may position the flame at a predetermined and/or suitable position relative to the fuel nozzle  
20 and/or relative to one or more components or elements of a burner or combustion system. For example, positioning the flame at a predetermined and/or suitable position relative to the fuel nozzle may stabilize the flame and prevent blow off thereof (*e.g.*, resulting in a stable and/or continuous combustion). Furthermore, in some embodiments, the flame may be repositioned to one or more suitable locations (*e.g.*, during operation of the burner  
25 or combustion system). For instance, the flame positioning and stabilization system may reposition the flame from a first location (*e.g.*, near the flame nozzle) to a second location (*e.g.*, farther away from the nozzle).

**[0026]** In one or more embodiments, a burner or combustion system may include a flame holder positioned downstream from the nozzle. The fuel flowing from the fuel  
30 nozzle may flow toward and/or to the flame holder. Moreover, for example, the fuel may be ignited and/or combusted at or near the flame holder. In some embodiments, the flame produced during combustion of the fuel may be anchored to or positioned on and/or within the flame holder. The flame positioning and stabilization system may raise or

reposition the flame downstream such that the flame is repositioned from a first position to a second position that is closer to the flame holder than the first position.

[0027] Under some operating conditions, the flame may be gradually and/or continuously moved downstream and closer to the flame holder in a manner that prevents extinguishing or blowing out the flame. Furthermore, as the flame moves closer to the flame holder, the flame holder may be heated (*e.g.*, to an operating temperature). For example, the flame holder may be heated to a temperature sufficient to ignite the fuel and/or maintain combustion thereof. For instance, the fuel flowing from the fuel nozzle may be ignited at or near the flame holder without any additional source of ignition (*e.g.*, the flame holder may raise the temperature of the fuel to at least the ignition temperature thereof). Accordingly, in some embodiments, the ignition and/or combustion occurring upstream from the flame holder (*e.g.*, as the fuel flowing from the fuel nozzle that ignites before reaching the flame holder) may be discontinued and/or transferred to ignition and/or combustion at or near the flame holder (*e.g.*, such that the flame attaches to the flame holder). For example, the flame may be transferred from burning in the stream or flow of fuel to the flame holder, which may provide additional stability, reduce NO<sub>x</sub>, improve fuel efficiency, etc.

[0028] FIG. 1 is an isometric view of a burner 100 according to an embodiment. The burner 100 includes a fuel nozzle 110 and a flame holder 120 positioned downstream from the fuel nozzle 110. In some embodiments, the fuel nozzle 110 and the flame holder 120 may be positioned in a combustion volume 130. Generally, the combustion volume 130 may be defined by any number of walls and/or other elements or components of the burner 100. For example, the combustion volume 130 may be in part defined by a wall 140.

[0029] In some embodiments, the fuel nozzle 110 may extend into the combustion volume 130 (*e.g.*, through an aperture 141 in the wall 140). For example, the aperture 141 may be sized and configured to permit oxidant, such as air, to enter the combustion volume 130 to facilitate combustion of a fuel (*e.g.*, fuel 10) flowing from the fuel nozzle 110. For instance, the flow of fuel 10 may entrain air that may enter through the aperture 141 and mix with the flowing fuel.

[0030] The term air refers to all suitable oxidants, which may be liquid and/or gaseous and may include oxygen in a form that can support combustion. For example, a suitable oxidant may be ambient air that, in some instances, may be mixed with additives that may be selected for modifying combustion characteristics. In some embodiments,

flue gases may be recirculated and mixed with ambient air to reduce the oxygen concentration in the mixed oxidant supplied for mixing with the fuel.

**[0031]** Generally, the fuel nozzle 110 and the flame holder 120 may be secured to and/or integrated with any number of elements or components of the burner 100 in a manner that positions the flame holder 120 downstream from the fuel nozzle 110. For example, the flame holder 120 may be positioned at a distance  $D_1$  downstream from a tip of the fuel nozzle 110 (*e.g.*, from a location at which the fuel may flow out of the fuel nozzle 110). The flame holder 120 may include a refractory material (*e.g.*, ceramic). Moreover, in some embodiments, the flame holder 120 includes multiple apertures 121 or openings that extend from a first face 122 to a second face 123 of the flame holder.

**[0032]** The flame holder 120 may be positioned with the first face 122 toward the fuel nozzle 110 (*e.g.*, the first face 122 may be spaced from the fuel nozzle 110 by the distance  $D_1$ ). In the illustrated embodiment, the first and second faces 122, 123 of the flame holder 120 are generally planar. Additionally or alternatively, the first and/or second faces 122, 123 may lie in a plane that is generally perpendicular to a longitudinal axis of the fuel nozzle 110. In at least one embodiment, the flame holder 120 may include faces that may be non-planar and/or which may lie at different angles with respect to each other and/or with respect to the longitudinal axis of the fuel nozzle 110.

**[0033]** Under some operating conditions, the fuel 10 may flow from the fuel nozzle 110 (*e.g.*, the fuel 10 may be ejected from the fuel nozzle 110) toward the first face 122 of the flame holder 120 (*e.g.*, as schematically indicated with the arrows). In some embodiments, the fuel 10 may disperse from the fuel nozzle 110 in a generally conical spray (*e.g.*, at an angle that is about  $7.5^\circ$  from the longitudinal axis, resulting in a solid conical angle of about 15 degrees). It should be appreciated that the fuel may flow out of the fuel nozzle 110 and toward the flame holder 120 in any number of suitable patterns or shapes, which may vary from one embodiment to another.

**[0034]** As the fuel 10 flows, the fuel 10 may entrain air and may reach a flammable or combustible proportion of fuel and air. For instance, by selecting a suitable fuel nozzle and the pressure at which fuel is ejected therefrom, a suitable speed for fuel flow may be selected. In some embodiments, the speed at which the fuel 10 flows from the fuel nozzle 110 may be selected to be much higher than the flame propagation speed of the particular type of fuel employed. As such, for example, on the one hand, the fuel stream may be prevented from supporting a flame near the nozzle, and on the other hand, by the time the fuel 10 has slowed to near the flame propagation speed, the fuel stream

has entrained enough air that the mixture is too lean for combustion at the temperature of the fuel and air mixture or stream.

[0035] Additionally or alternatively, under some operating conditions, the flame holder 120 may be at a much higher temperature than the temperature of the fuel and air mixture (*e.g.*, during ongoing combustion at or near the flame holder 120). The higher temperature of the flame holder 120 may be sufficient to maintain combustion of a lean fuel mixture (*e.g.*, a stable flame may be maintained by the flame holder 120). The flame may be held within the apertures 121 and/or may extend a short distance beyond either or both of the first and second faces 122, 123 of the flame holder 120. The fuel 10 may continually feed the combustion, and the flame holder 120 may support a leaner flame than could be maintained in a conventional burner system. The distance  $D_1$  may vary from one embodiment to the next and may be selected, at least in part, based on a suitable or a desired fuel-to-air ratio of the fuel 10 at the location where the fuel-air mixture contacts the flame holder 120.

[0036] As described above, in some embodiments, the burner 100 may include a flame positioning and stabilization system, which may position the flame at any number of suitable positions between the fuel nozzle 110 and the flame holder 120 (*e.g.*, at any distance from the first face 122 of the flame holder 120, which is less than  $D_1$ ). **FIGS. 2A-2C** illustrate a burner 100a that includes a flame positioning and stabilization system according to an embodiment. Except as otherwise described herein, the burner 100a and its elements and components may be similar to or the same as the burner 100 (**FIG. 1**) and its respective elements and components. For example, the burner 100a may include a fuel nozzle 110a generally directed toward and spaced apart from a flame holder 120a, which may be similar to or the same as the respective fuel nozzle 110 and flame holder 120 (**FIG. 1**).

[0037] As shown in **FIG. 2A**, as the fuel 10 combusts, according to an embodiment, a flame 20 may be produced. Generally, the flame 20 may extend downstream from the fuel nozzle 110a and toward the flame holder 120a. In some embodiments, the flame 20 may be positioned at a distance 30a from the fuel nozzle 110a and may extend downstream from the fuel nozzle 110a. For example, the flame 20 may extend downstream such that the flame is spaced away from the flame holder 120 by a distance 40a. As noted above, the position of the flame 20 relative to the fuel nozzle 110a and/or relative to the flame holder 120a may be adjusted and/or controlled by a flame positioning and stabilization system 200a.

**[0038]** In an embodiment, the flame positioning and stabilization system 200a may include a first fuel supply 210a that may contain and/or supply a first fuel, and which may be operably coupled to the fuel nozzle 110a. For example, the first fuel supply 210a may be in fluid communication with the fuel nozzle 110a such that the first fuel may flow  
5 to and out of the fuel nozzle 110a. In some embodiments, the flame positioning and stabilization system 200a may include a first valve 220a that may control (*e.g.*, regulate) the flow of the first fuel from the first fuel supply 210a to and/or out of the fuel nozzle 110a.

**[0039]** In at least one embodiment, the flame positioning and stabilization system  
10 200a include a second fuel supply 230a that may contain and/or supply a second fuel, and which may be operably coupled to the fuel nozzle 110a. For example, the second fuel supply 230a may be in fluid communication with the fuel nozzle 110a, such that the second fuel may flow to and out of the fuel nozzle 110a. In some embodiments, the flame positioning and stabilization system 200a may include a second valve 240a that  
15 may control or regulate the flow of the second fuel from the second fuel supply 230a to and/or out of the fuel nozzle 110a.

**[0040]** In one or more embodiments, the flow of the first and second fuels may be regulated and/or adjusted to position the flame 20 at a suitable and/or predetermined position relative to the fuel nozzle 110a and/or relative to the flame holder 120a. For  
20 example, the first fuel may have a first flame speed, and the second fuel may have a second flame speed that may be greater than the first flame speed. Hence, for instance, the flame produced from ignition and/or combustion of the first fuel may be located farther from the fuel nozzle than the flame produced from ignition and/or combustion of the second fuel.

**[0041]** In one or more embodiments, the flame positioning and stabilization  
25 system 200a may position the flame at a suitable and/or predetermined position by mixing the first and second fuel. In particular, for example, the amount of first and second fuels flowing from the fuel nozzle 110a may be controlled by the flame positioning and stabilization system 200a, which may produce a suitable and/or predetermined location of  
30 the flame produced during the ignition of the first and second fuel mixture. Moreover, in some instances, 100% of the fuel flowing from the fuel nozzle may be the first or the second fuel (*e.g.*, to produce a predetermined flame location).

**[0042]** Generally, as discussed above, the first and second fuels may have different flame speeds. For example, the first fuel may have a lower flame speed than the

second fuel. It should be appreciated that the first and/or second fuels may include any number of suitable fuels or combinations of fuels (*e.g.*, fuel mixtures), which may vary from one embodiment to the next. Moreover, the first and/or second fuel may be in any suitable phase (*e.g.*, gas, liquid, or semi-liquid). According to an embodiment, the first  
5 fuel may be methane (CH<sub>4</sub>) and the second fuel may be hydrogen (H<sub>2</sub>) or propane (C<sub>3</sub>H<sub>8</sub>). For example, propane has a faster flame speed than methane, but a slower flame speed than hydrogen. As another example, the first fuel may be propane and the second fuel hydrogen.

**[0043]** Additionally or alternatively, the flame positioning and stabilization  
10 system 200a may adjust or control the size of the flame 20. In an embodiment, the pressure and/or speed of the fuel 10 exiting the fuel nozzle 110a may be controlled by the first and/or second valves 220a, 240a. Hence, for instance, by increasing the fuel pressure and/or flow speed out of the fuel nozzle 110a, the flame size and/or length may be increased and/or controlled to produce the flame 20 of a suitable size and/or length.  
15 Moreover, the position of a tip of the flame 20 relative to the flame holder 120a may be controlled by selecting a suitable flame size (*e.g.*, the distance 40a may be varied or controlled to a suitable distance by the flame positioning and stabilization system 200a).

**[0044]** In one or more embodiments, the flame positioning and stabilization  
20 system 200a may include a controller 250a operably coupled to the first and second valves 220a, 240a. The controller 250a may operate the first and second valves 220a, 240a to regulate the mixture or composition of the fuel 10 exiting the fuel nozzle 110a, thereby controlling (*e.g.*, regulating) the position of the flame 20, the distance 30a between a base of the flame 20 and the fuel nozzle 110a, the distance 40a between the tip of the flame 20 and the flame holder 120a, combinations of the foregoing, etc., in a  
25 manner described above.

**[0045]** Moreover, in some embodiments, the flame positioning and stabilization  
system 200a may include one or more sensors and/or detectors operably coupled to the controller 250a. For instance, the sensors and/or detectors may detect positions of the base and/or tip of the flame 20, flame temperature, fuel temperature, etc. In some  
30 embodiments, the sensors and/or detectors may be positioned inside a combustion volume 130a. In an embodiment, the controller may operate (directly or indirectly) the first and/or second valves 220a, 240a to produce or change the position and/or size of the flame at least in part based on the signals or readings provided to the controller 250a from the sensors and/or detectors.

[0046] FIG. 2A schematically illustrates the flame 20 at a first location, where a base of the flame 20 is spaced from the fuel nozzle 110a by the distance 30a and a tip of the flame 20 is spaced from the flame holder 120 by the distance 40a. For example, to position the flame at the first location, the fuel 10 exiting the fuel nozzle 110a may be 5 100% second fuel (*e.g.*, the fuel flowing out of the fuel nozzle 110a may be substantially only H<sub>2</sub> or other suitable fuel). Hence, under some operating conditions, the first valve 220a may be substantially closed, while the second valve 240a may be open (*e.g.*, in a manner to produce a suitable or desired pressure and/or speed of flow of the second fuel out of the fuel nozzle 110a).

10 [0047] As shown in FIG. 2B, fuel 10' exiting the fuel nozzle 110a may be ignited to produce a flame 20' that may be positioned at a second location (*e.g.*, a base of the flame 20' may be spaced at a distance 30a' from the fuel nozzle 110a and a tip of the flame 20' may be spaced at a distance 40a' from the flame holder 120a). For example, the flame positioning and stabilization system 200a may provide first and second fuels to the fuel nozzle 110a; the first and second fuels may mix together (*e.g.*, before and/or after 15 exiting the fuel nozzle 110a) to produce the mixed fuel 10'. More specifically, for example, combustion of the mixed fuel 10' may produce the flame 20' at the distance 30a' that may be greater than the distance 30a (FIG. 2A). As the composition of the fuel exiting the fuel nozzle 110a changes from a first composition (producing fuel 10) to a second composition (producing fuel 10'), the base of the flame 20' may move 20 downstream and away from the fuel nozzle 110a, thereby repositioning the flame relative to the fuel nozzle 110a and relative to the flame holder 120a. Moreover, under some operating conditions, as the base of the flame moves downstream from the fuel nozzle 110a, the flame shape and/or size may be reconfigured (*e.g.*, from flame 20 to flame 20').

25 [0048] As mentioned above, the flame positioning and stabilization system 200a may control the pressure and/or speed of the fuel flowing out of the fuel nozzle 110a. Hence, the flame positioning and stabilization system 200a may change or maintain the distance 40a' of the flame 20' from the flame holder 120a. For example, the flame may be maintained at the same distance from the flame holder 120a as the flame composition 30 is changed (*e.g.*, the distance 40a' from the flame holder 120a to the tip of the flame 20' may be the same as the distance 40a to the tip of the flame 20 (FIG. 2A)). For instance, the controller 250a may adjust the flow of the first and second fuels by operating respective first and second valves 220a, 240a (*e.g.*, based on information from position

sensors in the combustion chamber 130a in a manner that the distance 40a' is approximately the same as the distance 40a (**FIG.2A**)).

**[0049]** As noted above, the second fuel may have a higher flame speed than the first fuel. Hence, increasing the amount of the first fuel relative to the amount of the second fuel (*e.g.*, in the composition of fuel) may produce the fuel 10' that has an overall lower flame speed than the fuel 10. For instance, the fuel 10' may include 75% H<sub>2</sub> and 25% CH<sub>4</sub>. It should be appreciated that, as noted above, any number of suitable fuels may be mixed in any number of proportions to produce a second fuel that has a lower flame speed than a first fuel.

**[0050]** Furthermore, under some operating conditions, the temperature in the combustion chamber 130a may increase (*e.g.*, during continuous combustion of the fuel 10 (**FIG. 2A**) and/or fuel 10a'). Hence, for example, the flame positioning and stabilization system 200a may move the flame downstream from the fuel nozzle 110a as the temperature in the combustion chamber 130a increases in a manner that may support the flame 20' at the distance 30a' from the fuel nozzle 110a (*e.g.*, without blow off of the flame 20'). In other words, the position of the flame 20' and/or the distance 30a' between the base of the flame 20' and the fuel nozzle 110a may be based on or related to: the flame speed and/or composition of the fuel 10' (*e.g.*, as adjusted from the flame speed of the first fuel), speed of the flow of fuel 10', temperature in the combustion chamber, pressure in the combustion chamber, equivalence ratio, oxidant temperature, unburnt fuel temperature, or combinations of the foregoing. In an embodiment, the controller 250a may operate (directly or indirectly) the first and/or second valves 220a, 240a at least partially based on a requested or suitable position of the flame, speed of the flow of fuel 10' out of the fuel nozzle 110a, temperature in the combustion chamber 130a, or combinations thereof. In any event, in some embodiments, as the flame positioning and stabilization system 200a increases the flame speed of the fuel composition exiting the fuel nozzle 110a, the flame moves upstream (*e.g.*, away from the flame holder 120a and toward the fuel nozzle 110a). Conversely, in an embodiment, as the flame positioning and stabilization system 200a decreases the flame speed of the fuel composition exiting the fuel nozzle 110a, the flame moves downstream (*e.g.*, away from the fuel nozzle 110a and toward the flame holder 120a).

**[0051]** The flame positioning and stabilization system 200a may continue to adjust the mixture of the fuel exiting the fuel nozzle 110a (*e.g.*, as the temperature in the combustion chamber increases), thereby moving the flame further downstream and away

from the fuel nozzle 110a. The stabilization system 200a may adjust the mixture (*e.g.*, continuously adjust the mixture) to move the flame upstream in response to one or more parameters (*e.g.*, in response to a drop ambient temperature, increase in heat load, etc.). For example, as shown in **FIG. 2C**, combustion of fuel 10'' (which may have a lower flame speed than the fuel 10' (**FIG. 2B**)) may produce a flame 20'' that is farther downstream and away from the fuel nozzle 110a (*e.g.*, base of which is positioned at a distance 30a'' from the fuel nozzle 110a) than the flame 20' (**FIG. 2B**). In other words, for instance, the fuel 10'' may include a greater percentage of the first fuel than the fuel 10' (**FIG. 2C**). For example, the fuel 10'' may include 75% CH<sub>4</sub> and 25% H<sub>2</sub> (the values are only example; also, the schematic views in **FIGS. 2A-2C** are not to scale).

**[0052]** Furthermore, distance 40a'' between the tip of the flame 20'' and the flame holder 120a may be maintained the same as the distance 40a' (**FIG. 2B**) and/or distance 40a (**FIG. 2A**) or may be changed. For example, the distance between the tip of the flame and the flame holder 120a may be gradually or continuously decreased as the temperature in the combustion chamber 130a increases and/or as the flame is moved downstream from the fuel nozzle 110a. Moreover, as described above, the flame may be moved and/or anchored to the flame holder 120a.

**[0053]** For example, as shown in **FIG. 3A** a flame 20a produced from combusting fuel 10a may be moved downstream from the fuel nozzle 110a (as compared with flame 20'' (**FIG. 2C**)) to the flame holder 120a (*e.g.*, to the upstream facing face of the flame holder 120a). In some embodiments, the fuel 10a may have a lower flame speed than the fuel 10'' (**FIG. 2C**). Hence, for instance, the fuel 10a may flow farther downstream from the fuel nozzle 110a than the fuel 10'' (**FIG. 2C**) without ignition or combustion. For example, the fuel 10a may include a greater percentage of the first fuel (fuel with lower flame speed) than the fuel 10''.

**[0054]** In an embodiment, the fuel 10a may be ignited or may combust at or near the flame holder 120a, thereby forming the flame 20a, which may be anchored to the flame holder 120a in a number of suitable ways. For instance, the flame 20a may be anchored near the upstream facing face of the flame holder 120a. For example, the flame positioning and stabilization system 200a may control the speed and mixture of fuel such that the fuel 10a does not combust before reaching the flame holder 120a. Under some operating conditions, the flame produced upstream from the flame holder 120a may be extinguished (*e.g.*, the flame 20'' (**FIG. 2C**) may be extinguished) as the mixture of the fuel exiting the fuel nozzle 110a is modified (*e.g.*, to fuel 10a), flame 20a may be ignited

at the flame holder 120a. Alternatively, the flame may move downstream from the fuel nozzle 110a and to the flame holder 120a without being extinguished.

[0055] Moreover, the mixture of the fuel may be further adjusted to position and/or reposition the flame relative to the faces of the flame holder 120a. For example, as shown in **FIG. 3B**, flame 20a' produced from ignition of fuel 10a' may move into openings or apertures in the flame holder 120a. For example, the flame speed of the fuel 10a' may be lower than the flame speed of fuel 10a (**FIG. 3A**). In an embodiment, as noted above, the flame speed of the fuel 10a (**FIG. 3A**) may be lowered by increasing the proportion of the first fuel (relatively lower flame speed fuel) and/or decreasing the percentage of the second fuel (relatively higher flame speed fuel). Additionally or alternatively, the speed of the flow of fuel 10a' may be higher than the speed of the flow of fuel 10a (**FIG. 3A**).

[0056] For example, the flame 20a' may be substantially or mostly contained within the apertures 121a of the flame holder 120a. Further increasing the proportion of the first fuel (relatively lower flame speed fuel) relative to the second fuel (relatively higher flame speed fuel) may produce fuel 10a'', combustion of which may result in a flame 20a'' that may extend past the flame holder 120a, as shown in **FIG. 3C**. In other words, the fuel 10a'' may have a lower flame speed than the fuel 10a' (**FIG. 3B**) and may ignite and/or combust farther downstream from the fuel nozzle 110a than the fuel 10a'. In any event, the fuel 10a'' may be ignited and combusted within the apertures 121a of the flame holder 120a and may extend therethrough and past a downstream facing face of the flame holder 120a. In an embodiment, the flame 20a'' may at least partially surround the flame holder 120a.

[0057] Generally, as described above, the flame may be moved downstream and/or upstream during the operation of the burner. For example, during the startup of the burner, the flame may be initially positioned at a first position (*e.g.*, close to the fuel nozzle). In some embodiments, as the temperature in the combustion chamber increases, the flame may be advanced or repositioned downstream from the fuel nozzle (*e.g.*, the increased temperature in the combustion chamber may sustain a flame without blow-out thereof when combusting a fuel with lower flame speed). Moreover, as the flame holder reaches the operating temperature at which combustion of the fuel may be sustained, the flame may be moved to the flame holder (*e.g.*, by lowering the flame speed of the fuel, increasing the speed of the fuel flow).

[0058] In alternative or additional embodiments, the base of the flame may be anchored or positioned at a predetermined and/or suitable location relative to the fuel nozzle by selectively providing a second fuel injection or flow to such a location. **FIGS. 4A-4C** illustrate a burner 100b that includes a primary fuel nozzle 110b that may provide a primary fuel and a secondary fuel nozzle 230b that may provide a secondary fuel (*e.g.*, for anchoring or positioning the flame at a suitable location relative to the primary fuel nozzle 110b), according to an embodiment. Except as otherwise described herein, the burner 100b and its elements and components may be similar to or the same as any of the burners 100, 100a (**FIGS. 1-3C**) and their respective elements and components.

[0059] For example, the burner 100b includes the primary fuel nozzle 110b that may be similar to or the same as the fuel nozzle 110a (**FIGS. 2A-3C**). In an embodiment, fuel 10c may flow out of the primary fuel nozzle 110b and may be ignited to at least partially to form flame 20c. Furthermore, in at least one embodiment, the burner 100b may include a flame positioning and stabilization system 200b that may have the secondary fuel nozzle 230b and a secondary valve 240b. For example, the secondary fuel nozzle 230b may eject or flow fuel 11c toward and/or to a location suitable for anchoring the flame 20c (*e.g.*, at a distance 30b from the primary fuel nozzle 110b).

[0060] In some embodiments, the fuel 11c may have a higher flame speed than the fuel 10c. Moreover, in some embodiments, the flow of fuel 11c may intersect the flow of fuel 10c at a location that is approximately at a distance 30b from the primary fuel nozzle 110b. As such, the fuel 11c may facilitate ignition at a suitable location and/or formation of the flame 20c (*e.g.*, at the location positioned downstream at the distance 30b from the primary fuel nozzle 110b).

[0061] As noted above, the primary fuel may have a lower flame speed than the secondary fuel. For example, the primary fuel may be methane, and the secondary fuel may be hydrogen. It should be appreciated, however, that the primary and secondary fuels may vary from one embodiment to the next and may include any number of suitable fuels, which may produce the primary fuel having a lower flame speed than the secondary fuel.

[0062] Generally, the secondary fuel nozzle 230b may be adjusted to supply fuel 11c to a suitable location downstream from the primary fuel nozzle 110b, such as to position the base of the flame 20c at a predetermined distance from the primary fuel nozzle 110b. For example, the secondary fuel nozzle 230b may be adjusted and/or positioned in a manner that the flow of the fuel 11c intersects the flow of the fuel 10c at a

suitable and/or predetermined distance downstream from the primary fuel nozzle 110b (e.g., at a distance 30b). Moreover, adjusting the secondary nozzle 230b and the location of the intersection of the fuel 11c with the fuel 10c may move or reposition the flame 20c relative to primary nozzle 110b.

5 [0063] In an embodiment, the secondary fuel nozzle 230b may be rotatable or pivotable about a pivot point 231b. For example, an actuator (not shown) operably coupled to the secondary fuel nozzle 230b may be configured to rotate or pivot the secondary fuel nozzle 230b under the direction of a controller (e.g., the controller 250a or similar controller) that may also control the secondary valve 240b and the valve  
10 associated with the primary fuel nozzle 110b. For example, the actuator may be a hydraulic actuator, magnetic actuator, electromagnetic actuator, electric motor actuator, or other suitable actuator. As the secondary fuel nozzle 230b pivots about the pivot point 231b, the fuel 11c may flow toward and/or intersect with the fuel 10c (e.g., the primary nozzle 110b and the secondary nozzle 230b may be oriented relative to each other at an  
15 angle  $\theta$ ). Adjusting the angle between the primary and secondary nozzles 110b, 230b may produce an adjusted intersection between the primary and secondary fuels 10c, 11c, which may move the flame relative to the primary fuel nozzle 110b. Furthermore, the secondary valve 240b may be operated to increase and/or decrease the pressure and/or the amount of the fuel 11c flowing from the secondary fuel nozzle 230b (e.g., in a manner  
20 that may accommodate an increased distance between the secondary nozzle 230b and the flow of the fuel 10c, as the secondary fuel nozzle 230b pivots about the pivot point 231b).

[0064] As shown in **FIG. 4B**, rotation or pivoting of the secondary fuel nozzle 230b about the pivot point 231b may produce an angle  $\theta'$  the primary fuel nozzle 110b and the secondary fuel nozzle 230b. In some embodiments, to move the flame farther  
25 downstream from the primary fuel nozzle 110b, the angle  $\theta'$  may be smaller than the angle  $\theta$  (**FIG. 4A**). For example, the angle  $\theta'$  may be selected to position flame 20c' (produced from combustion of fuel 10c and/or fuel 11c) at a distance 30b' from the primary fuel nozzle 110b, which may be greater than the distance 30b (**FIG. 4A**).

[0065] In additional or alternative embodiments, the secondary nozzle may be  
30 linearly repositioned in a manner that produces a repositioned intersection between the secondary and primary fuel. For example, the secondary nozzle may be configured to move generally downstream or upstream relative to the flow of fuel from the primary nozzle. As such, the secondary fuel may intersect the primary fuel at any suitable

location along the flow paths thereof between the primary nozzle and the flame holder, in a manner that positions the flame at or near such intersection.

[0066] In any event, the position of the flame between the primary nozzle 110b and the flame holder 120b may be controlled by adjusting the angle and/or downstream distance between the secondary nozzle 230b and the primary nozzle 110b. As shown in **FIG. 4C**, flame 20c'' may be positioned still closer to the flame holder 120b (and farther away from the primary nozzle 110b) as compared with flame 20c' (**FIG. 4B**). For example, the secondary nozzle 230b may be rotated or pivoted to produce an angle  $\theta''$  between the streams or flows of primary and secondary fuels 10c, 11c (angle  $\theta''$  may be smaller than the angle  $\theta'$  (**FIG. 4B**)), thereby moving the flame 20c'' farther away downstream from the primary nozzle 110b (as compared with flame 20c' (**FIG. 4B**)).

[0067] Furthermore, as mentioned above, a position of the tip of the flame relative to the primary fuel nozzle 110b and/or relative to the flame holder 120b may vary from one embodiment to another. Under some operating conditions, the tip of the flame 20c'' may be positioned closer to the flame holder 120b than the tip of the flame 20c' (**FIG. 4B**); for example, one or more of the speed, volume, or pressure of the fuel 10c exiting the primary nozzle 110b may be increased to move the tip of the flame closer to the flame holder 120b. Additionally, as described above, in some embodiments, the flame may be moved to the flame holder 120b (*e.g.*, after the flame holder reaches a suitable or operating temperature, which may sustain combustion of the primary fuel).

[0068] It should be appreciated that, in some embodiments, a burner may include any number of the mechanisms for controlling a position of the flame, which are described herein. For example, a burner may include the flame positioning and stabilization system 200a (**FIGS. 2A-2C**) and the flame positioning and stabilization system 200b. In other words, the flame position relative to the primary nozzle 110b may be controlled by adjusting the downstream position of the intersection between the primary and secondary fuels 10c, 11c and/or by controlling the flame speed of the fuel 10c (*e.g.*, as described above, by mixing fuels with different flame speeds to produce the fuel 10c). Moreover, the burner may include any number of additional or alternative mechanisms for controlling the position of the flame (*e.g.*, by adjusting the downstream position of the primary fuel nozzle 110b relative to the flame holder 120b, by charging the fuel with a first electrical charge and positioning an oppositely charged electrode at a downstream position suitable for anchoring the base of the flame during combustion of the charged fuel, etc.).

[0069] In alternative or additional embodiments, the base of the flame may be anchored or positioned at a predetermined and/or suitable location relative to a primary fuel nozzle by selectively providing an ignition source (*e.g.*, a secondary flame) at such suitable location. For example, a secondary fuel may be ignited and/or combusted and the flame from such combustion may ignite the fuel flowing from the primary fuel nozzle. 5 Additionally or alternatively, a spark igniter or any other suitable igniter may be positioned and/or repositioned at a suitable downstream position from the primary fuel nozzle to ignite the fuel flowing therefrom at such suitable downstream position.

[0070] Furthermore, it should be appreciated that the openings or perforations in the flame holder may vary from one embodiment to another. Particularly, the sizes and/or shapes of the openings may vary from one embodiment to the next. **FIG. 5A** is an isometric view of a flame holder 120c according to an embodiment. For example, the flame holder 120c may include apertures 121c that may be arranged in any suitable manner on a body 129c, which defines a general shape of the flame holder 120c and defines the apertures 121c thereof. 15

[0071] In an embodiment, the apertures 121c may have generally circular cross-sectional shapes (*e.g.*, at a cross-section taken transversely to a center axis of the aperture 121c). Furthermore, the size and/or shape of the opening may vary along a length thereof (*e.g.*, along the thickness of the body 129c). For example, one, some, or each of the apertures 121c may have an intermediate region located between inlet and outlet of thereof, and the intermediate region of the aperture 121c may have a smaller cross-section than the inlet and/or outlet of the aperture 121c. Furthermore, in some embodiments, the inlet and/or outlet of one, some, or each of the apertures 121c may at least partially flare outward, which may increase radiant heat transfer from the flame holder 120c. 20

[0072] **FIG. 5B** is a partial cross-sectional view the flame holder 120c shown in **FIG. 5A**; as indicated in **FIG. 5A**, the cross-section passes vertically through one of the apertures 121c. According to the illustrated embodiment, the aperture 121c has generally curved sidewalls that define the size and shape of the aperture 121c. In particular, the curved sidewalls of the aperture 121c define an intermediate region 124c that is located between inlet 125c and outlet 126c of the aperture 121c. In some embodiments, a cross-sectional area at the intermediate region 124c of the aperture 121c (*e.g.*, measured at the cross-section taken transversely to the cross-section shown in **FIG. 5B**) may be smaller than areas of the inlet 125c and/or outlet 126c. 25 30

[0073] In other words, the aperture 121c may be constricted at or around the

intermediate region 124c. As such, for example, fuel flow through the aperture 121c may exhibit a first velocity at or near the inlet 125c, a second velocity at or near the intermediate region 124c, and a third velocity at or near the outlet 126c. Generally, the second velocity (at the intermediate region 124c) may be higher than the first and/or third velocities (at the inlet 125c and outlet 126c, respectively). In at least one embodiment, the second velocity (at the intermediate region 124c) may be higher than the first and third velocities (at the inlet 125c and outlet 126c, respectively). Alternatively or additionally, the first velocity (at the inlet 125c) may be greater than the third velocity (at the outlet 126c) or vice versa.

10 [0074] In some embodiments, increased velocity of fuel flow at the intermediate region 124c of the aperture 121c may reduce or eliminate the risk of a flashback. In particular, as the fuel ignites at or near the flame holder 120c, the ignition may be such as to propagate flame upstream of fuel flow. Locally increased velocity of fuel flow at the intermediate region 124c of the aperture 120c may reduce the risk or instances of a flame propagating from the intermediate region 124c upstream and toward the fuel nozzle.

15 [0075] Moreover, the portion of the sidewall defining the inlet 125c and/or the outlet 126c may generally flare outward. In an embodiment, as described above, the portions of the sidewall at and near the inlet 125c and/or the outlet 126c may be generally curved. It should be appreciated that the aperture 121c at or near the inlet 125c and/or the outlet 126c may have a suitably shaped and sized sidewall (that defines the aperture 121c), which may vary from one embodiment to another.

[0076] Generally, the flame holder 120c may radiate heat from one or more exposed surfaces thereof. For example, as described above, the flame holder 120c may have first and second surfaces 122c, 123c (the first surface 122c facing upstream of the fuel flow, the second surface facing downstream of the fuel flow). In an embodiment, heat (*e.g.*, infrared light) may radiate from the first and second surface 122c, 123c (*e.g.*, generally perpendicular to the orientation of the respective first and second surfaces 122c, 123c), as indicated with the arrows.

[0077] As mentioned above, the flared portion(s) of the sidewall defining the aperture 121c at or near the inlet 124c and/or outlet 125c may increase exposed surface area of the flame holder 120c. In particular, heat may radiate from the flared portion(s) of the sidewall of the aperture 120c and toward one or more elements or components heated by a burner including the flame holder 120c (*e.g.*, pipes, walls, etc.). By contrast, from a sidewall of a generally cylindrical aperture, the heat may radiate internally and may be

generally trapped within the body 129c of the flame holder, which defines the cylindrical opening. It should be appreciated that radiating heat from the flare portion(s) of the sidewall defining the aperture 121c may decrease the operating temperature of the flame holder 120c and/or increase efficiency of heat transfer therefrom to one or more objects  
5 intended for heating thereby.

**[0078]** In other embodiments, a cross-sectional area at the intermediate region 124c of the aperture 121c (*e.g.*, measured at the cross-section taken transversely to the cross-section shown in **FIG. 5B**) may be larger than areas of the inlet 125c and/or outlet 126c. Such a bulging configuration is disclosed in U.S. Provisional Application No.  
10 62/096,612 filed on 24 December 2014, the disclosure of which is incorporated herein, in its entirety, by this reference.

**[0079]** While various aspects and embodiments have been disclosed herein, other aspects and embodiments are contemplated. The various aspects and embodiments disclosed herein are for purposes of illustration and are not intended to be limiting.

15

## CLAIMS

1. A method of controlling a downstream position of a flame relative to a primary fuel nozzle, the method comprising:
  - flowing a first fuel downstream from the primary fuel nozzle, the first fuel having  
5 a first flame speed;
  - mixing at least a portion of a second fuel flow with at least a portion of the first fuel, the second fuel having a second flame speed that is greater than the first flame speed; and
  - igniting one or more of at least a portion of the first fuel or at least a portion of the  
10 second fuel to produce the flame extending downstream from the primary fuel nozzle; and
  - controlling the downstream position of the flame relative to the primary fuel nozzle including one or more of controlling a relative proportion of the second fuel mixed with the first fuel or controlling the position of the second fuel flow relative to the  
15 primary fuel nozzle.
2. The method of claim 1 wherein the first fuel and the second fuel flow out of the fuel nozzle.
3. The method of claim 2 wherein controlling the downstream position of the flame relative to the primary fuel nozzle includes at least one of:
  - 20 decreasing the relative proportion of the second fuel to the first fuel so that the flame moves downstream from the primary fuel nozzle; or
  - increasing the relative proportion of the second fuel to the first fuel so that the flame moves upstream toward the primary fuel nozzle.
4. The method of claim 3 wherein controlling the downstream position of the flame  
25 relative to the primary fuel nozzle includes operating a first valve to control an amount of the first fuel flowing to the primary fuel nozzle and operating a second valve to control an amount of the second fuel flowing to the primary fuel nozzle.
5. The method of claim 1 wherein mixing at least a portion of a second fuel flow with at least a portion of the first fuel includes flowing the second fuel out of a secondary  
30 fuel nozzle so that the second fuel flow intersects the first fuel flow.
6. The method of claim 5, further comprising adjusting the secondary fuel nozzle in a manner that changes a position of intersection of the second fuel flow and the first fuel flow.

7. The method of claim 6 wherein adjusting the secondary fuel nozzle in a manner that changes a position of intersection of the second fuel flow and the first fuel flow includes pivoting the secondary fuel nozzle.
8. The method of claim 1 wherein flowing the first fuel downstream from the primary fuel nozzle includes flowing the first fuel toward a perforated flame holder including a plurality of apertures therein.
9. The method of claim 8, further comprising moving the flame downstream from a first position to a second position, the first position being closer to the primary fuel nozzle than the second position.
10. The method of claim 9, further comprising positioning the flame within at least some of the plurality of apertures of the perforated flame holder.
11. A burner, comprising:  
a perforated flame holder including a plurality of apertures therein;  
one or more fuel nozzles spaced from the perforated flame holder, the one or more fuel nozzles including a primary nozzle facing generally toward the perforated flame holder;  
a first fuel source operably coupled to the primary fuel nozzle of the one or more fuel nozzles, the first fuel source including a first fuel having a first flame speed;  
a second fuel source operably coupled to at least one of the one or more fuel nozzles, the second fuel source having a second flame speed that is greater than the first flame speed; and  
one or more control mechanisms configured to control one or more of a position of a flow of the second fuel relative to the first fuel or a relative proportion of the first and second fuels flowing toward the perforated flame holder.
12. The burner of claim 11 wherein the one or more fuel nozzles include a secondary fuel nozzle operably coupled to the second fuel source and configured to flow the second fuel in a direction to intersect the flow of the first fuel.
13. The burner of claim 12 wherein the secondary fuel nozzle is pivotable relative to the primary fuel nozzle such that pivoting the secondary fuel nozzle changes a downstream position of the intersection between flows of the first and second fuels.

14. The burner of claim 13 wherein one or more control mechanisms configured to control one or more of a position of flow of the second fuel relative to the first fuel or relative proportion of the first and second fuels flowing toward the perforated flame holder are configured to control pivoting of the secondary fuel nozzle.
- 5 15. The burner of claim 11 wherein the second fuel source is operable coupled to the primary fuel nozzle of the one or more fuel nozzles.
16. The burner of claim 11, further comprising a controller configured to modify a shape and/or a position of a flame produced from combustion of at least a portion of one or more of the first fuel or the second fuel flowing toward the perforated flame holder by  
10 operating the one or more control mechanisms to change position of a flow of the second fuel relative to the first fuel and/or to change a relative proportion of the first and second fuels flowing toward the perforated flame holder.
17. The burner of claim 16, further comprising one or more sensors coupled to the controller, the one or more sensors configured to detect a position of the flame relative to  
15 one or more of the perforated flame holder or to the primary fuel nozzle of the one or more fuel nozzles.
18. The burner of claim 17 wherein the controller is configured to modify the shape and/or position of a flame produced from combustion of at least a portion of one or more of the first fuel or the second fuel flowing toward the perforated flame holder at least  
20 partially based on signals received from the one or more sensors.
19. A burner, comprising:  
a perforated burner plate;  
a primary nozzle having a longitudinal axis and configured to flow a first fuel generally toward the perforated burner plate; and  
25 a flame control mechanism configured to produce ignition of the first fuel at or near the perforated burner plate by igniting the first fuel in a manner that forms a flame at a first position relative to the perforated burner plate and changing the position of the flame to a second position, the second position being closer to the perforated burner plate than the first position.  
30
20. The burner of claim 19 wherein the flame control mechanism configured to produce ignition of the first fuel at or near the burner plate changes a shape of the flame from a first shape at the first position to a second shape at the second position, the second shape being different from the first.

21. The burner of claim 19 wherein:

the primary nozzle is operably coupled to a first fuel source including a first fuel having a first flame speed; and

the flame control mechanism includes:

5 a second fuel source including a second fuel having a second flame speed that is greater than the first flame speed; and

a fuel introduction mechanism operably coupled to the second fuel source, the fuel introduction mechanism being configured to introduce the second fuel into the flow of the first fuel.

10

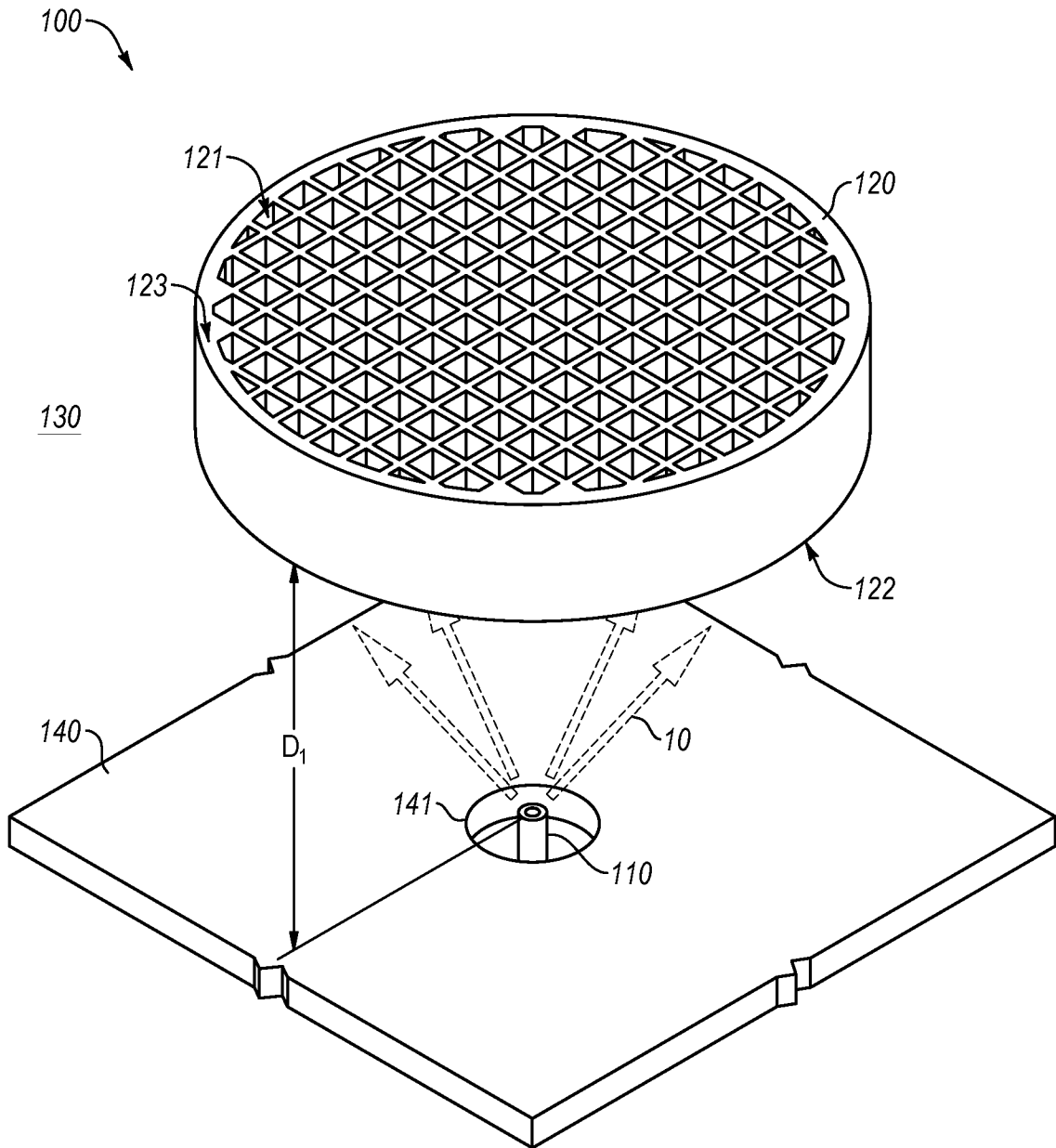

**Fig. 1**

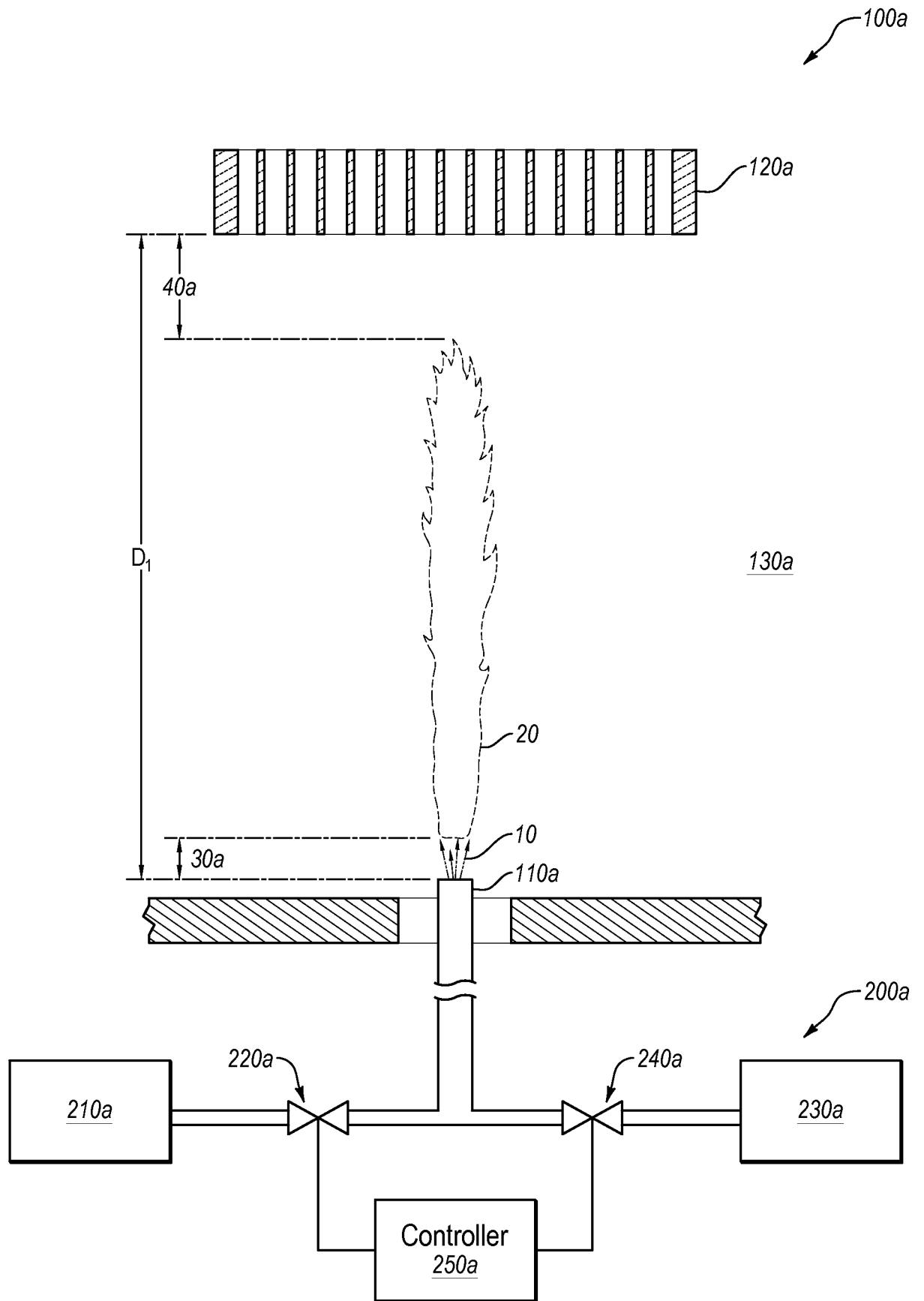
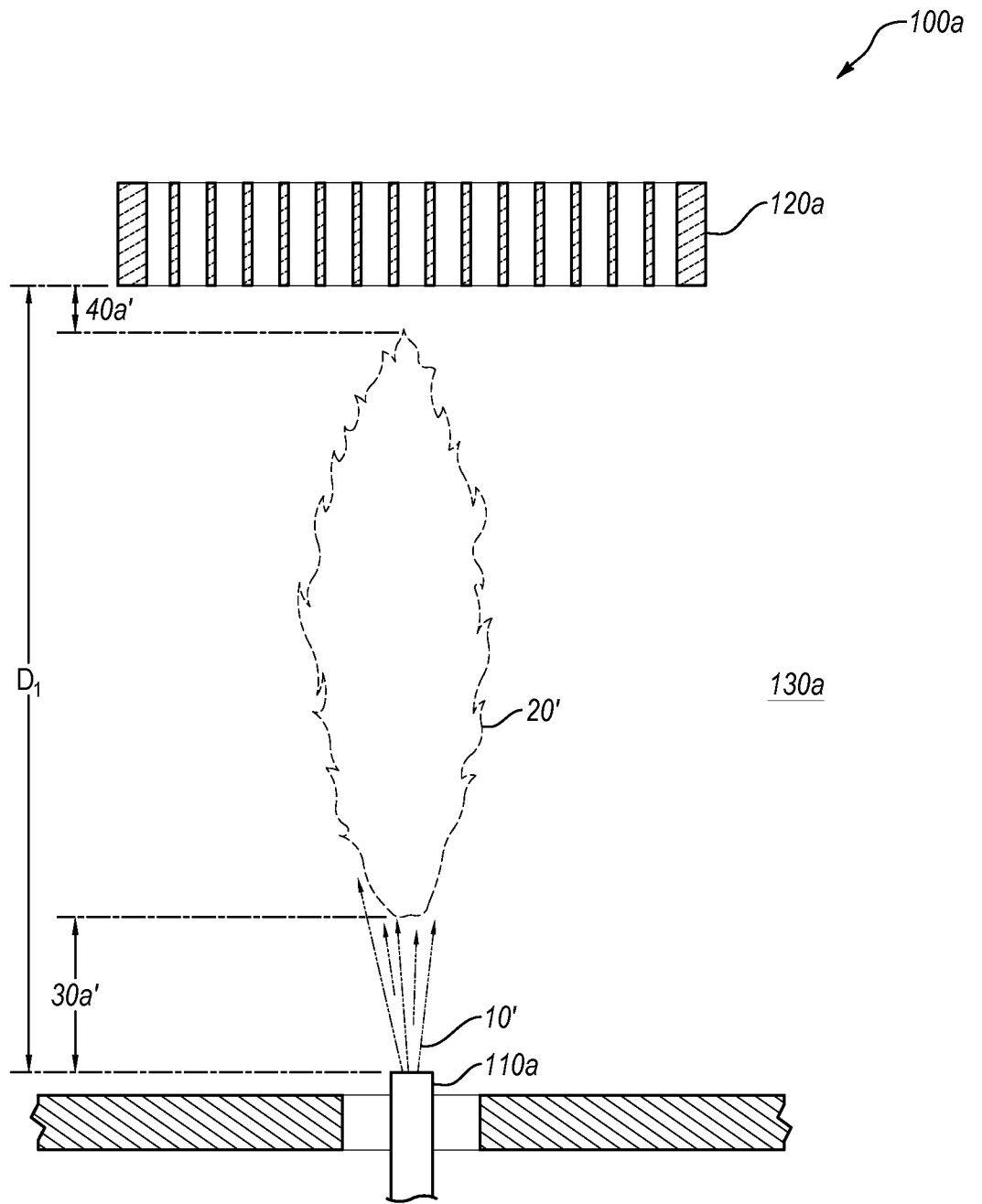

Fig. 2A



**Fig. 2B**

100a

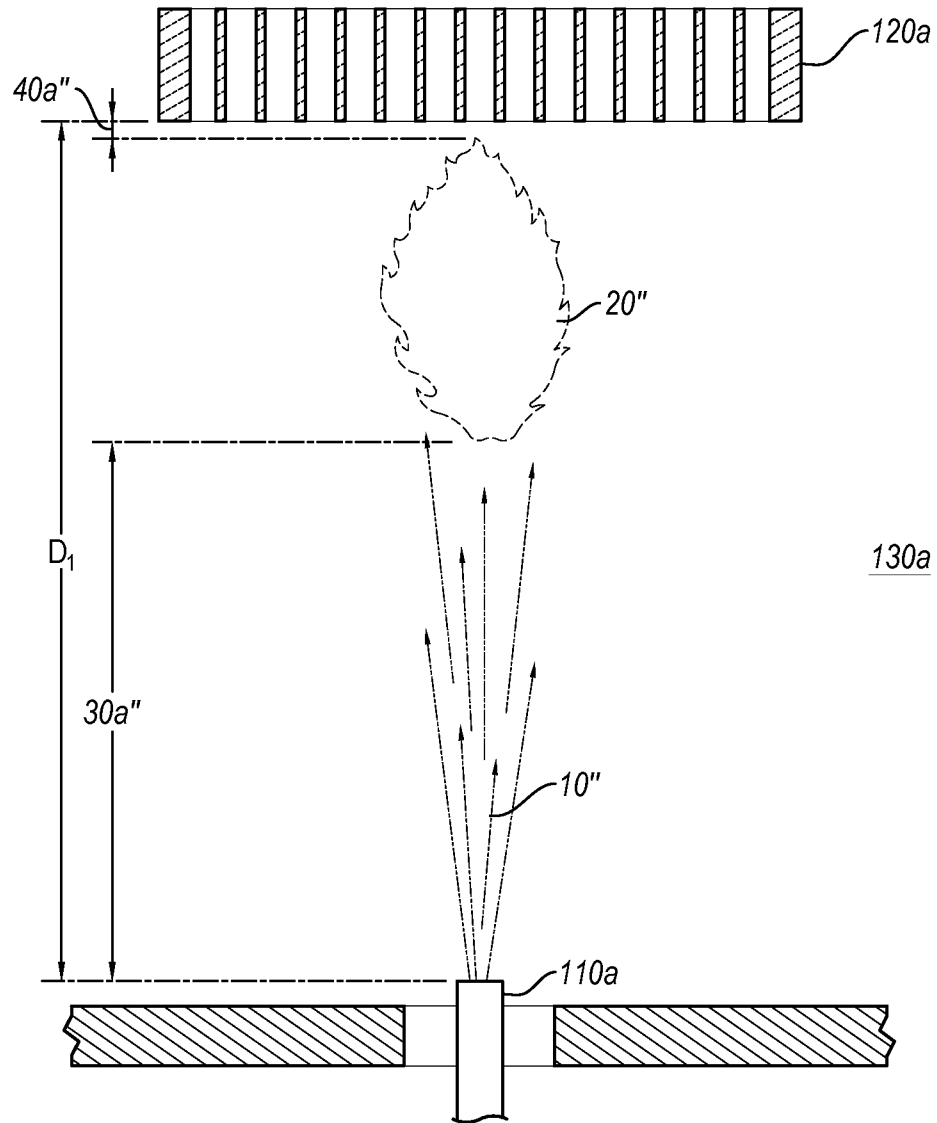
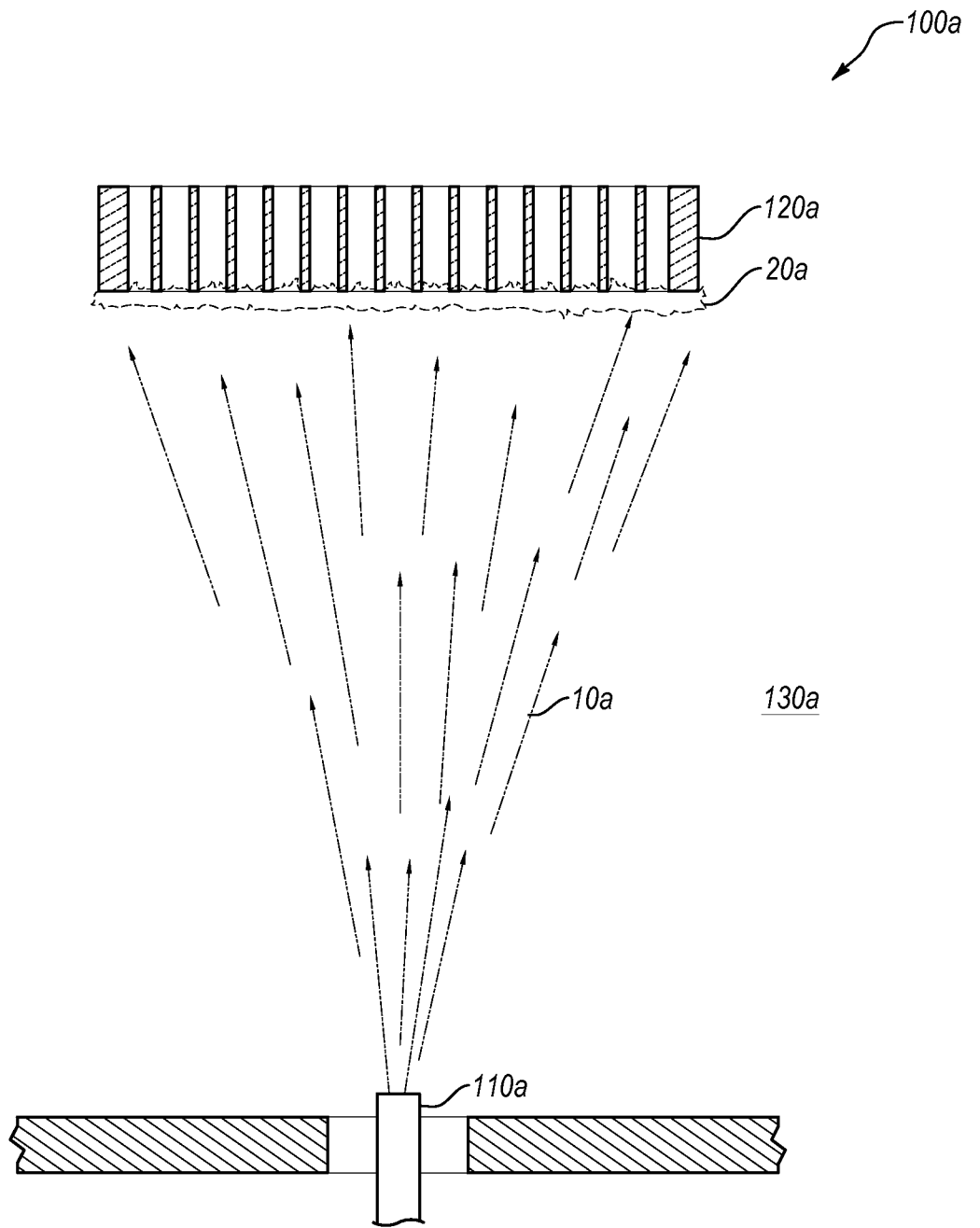
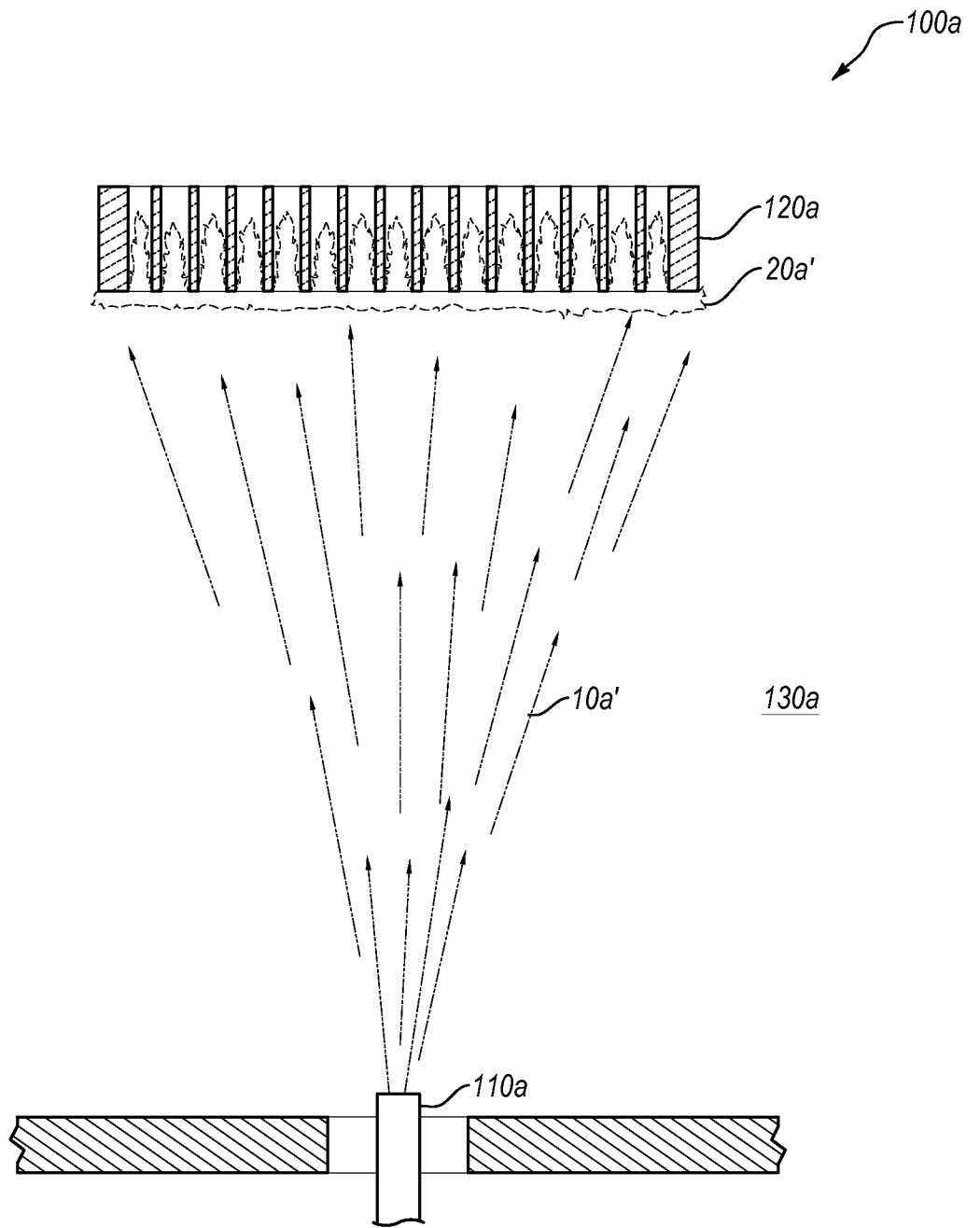

Fig. 2C



**Fig. 3A**



**Fig. 3B**

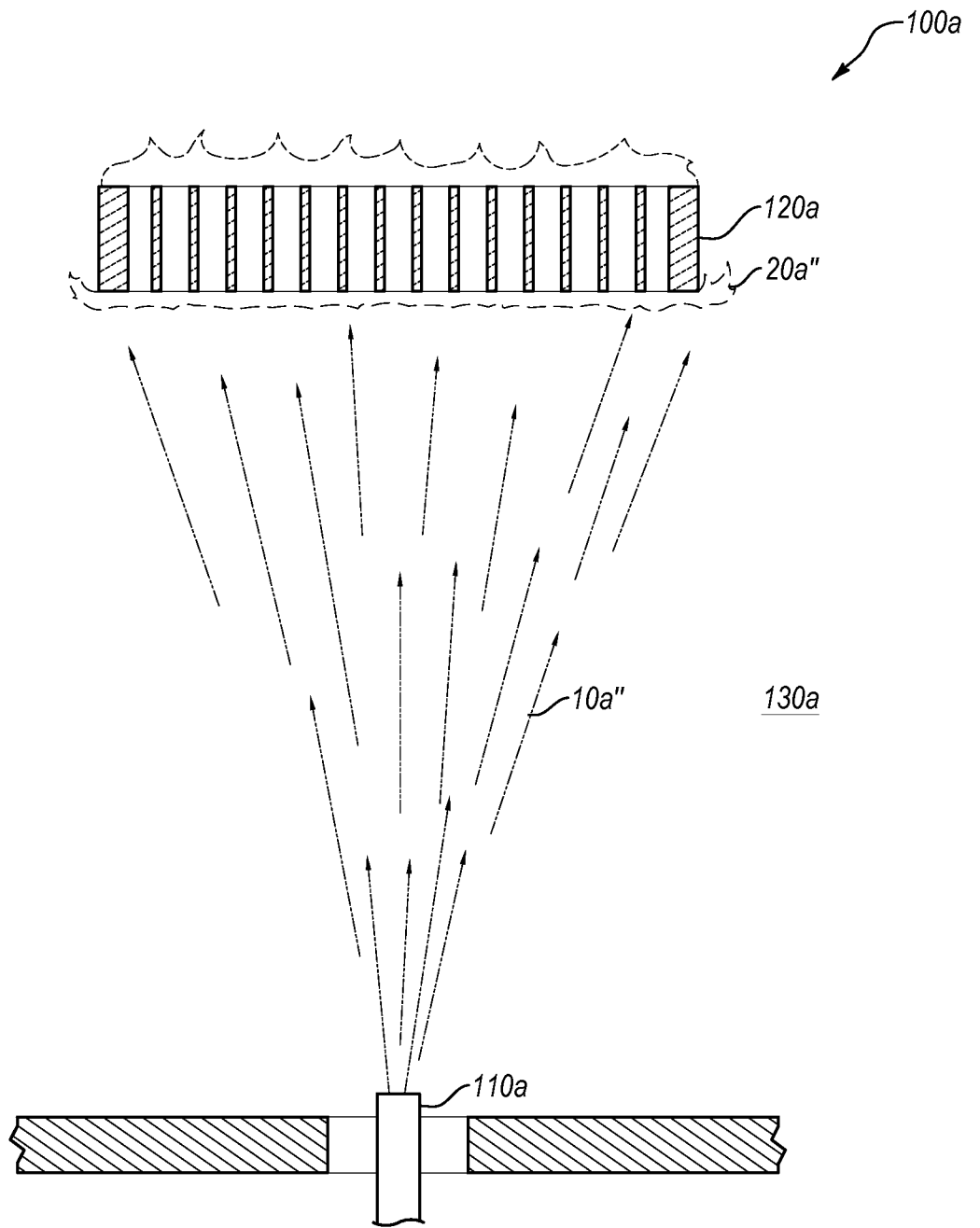

**Fig. 3C**

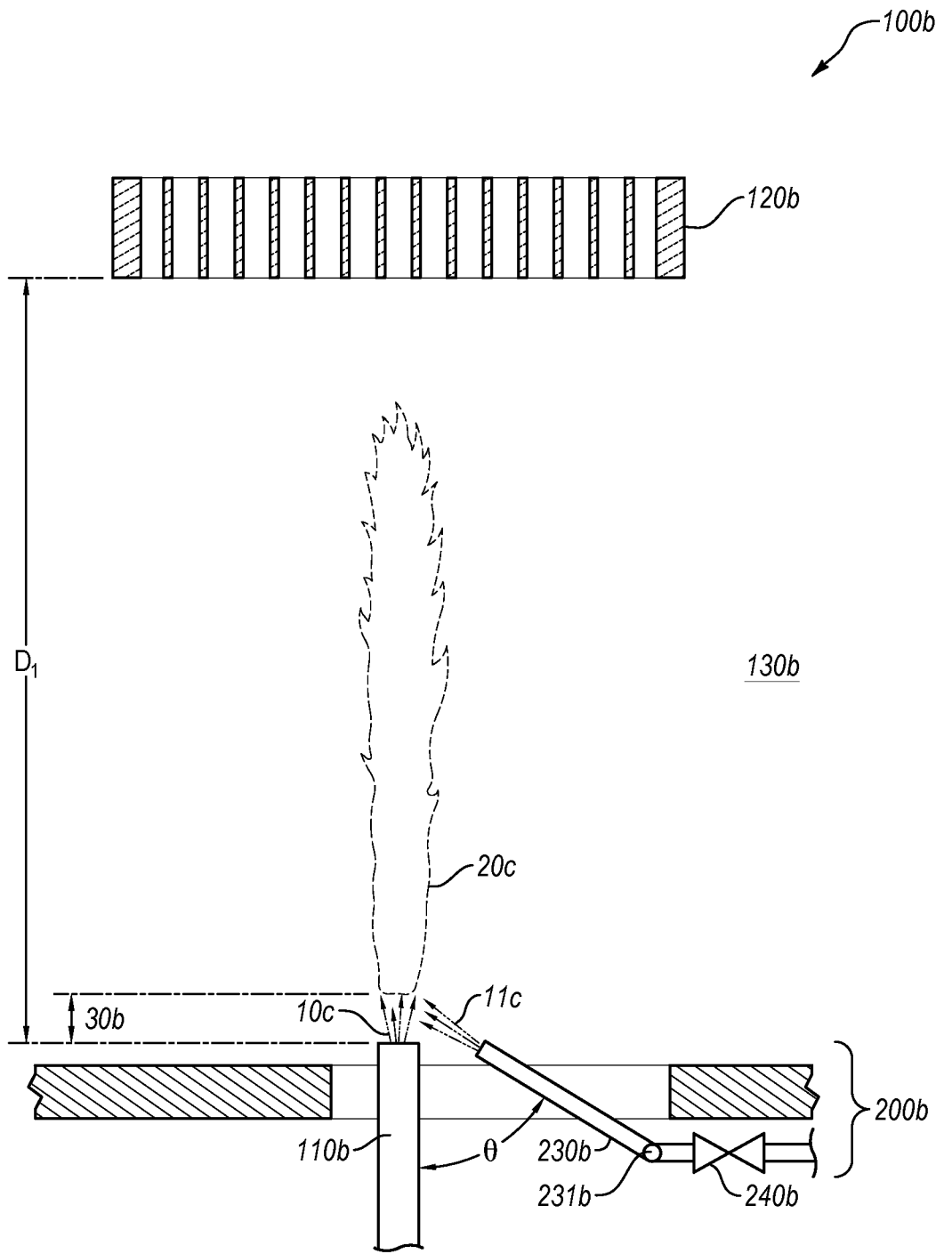

Fig. 4A

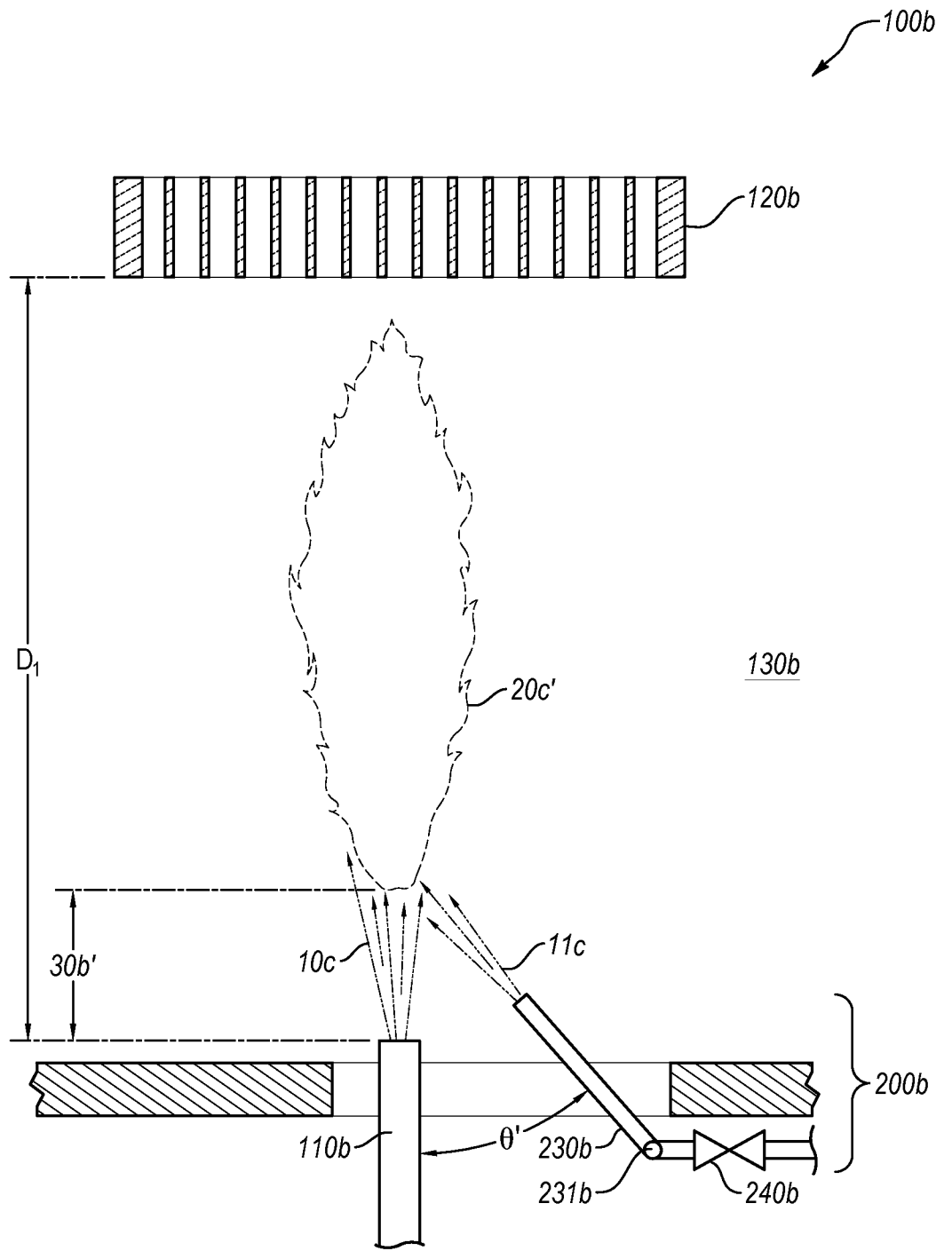

Fig. 4B

100b

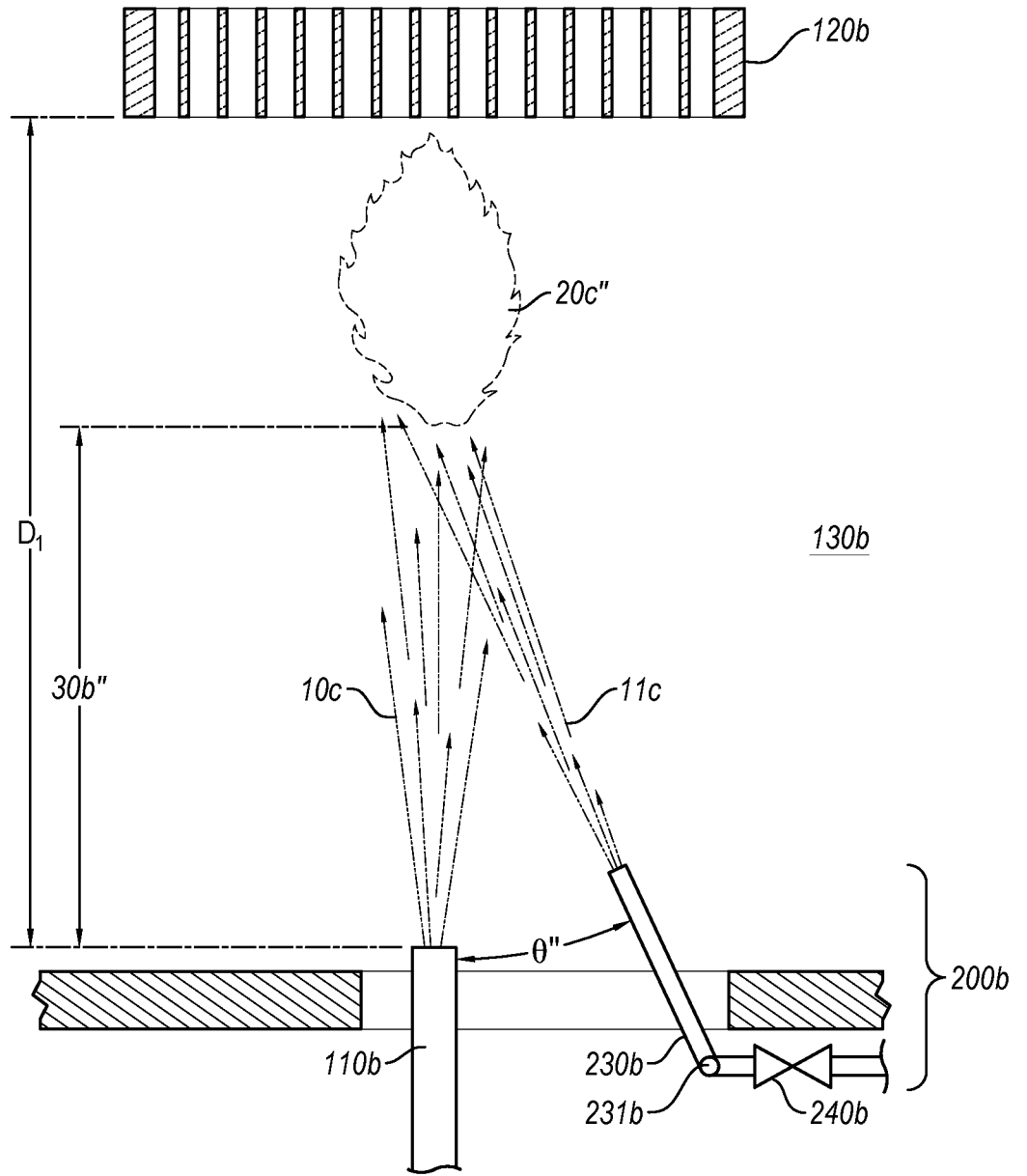
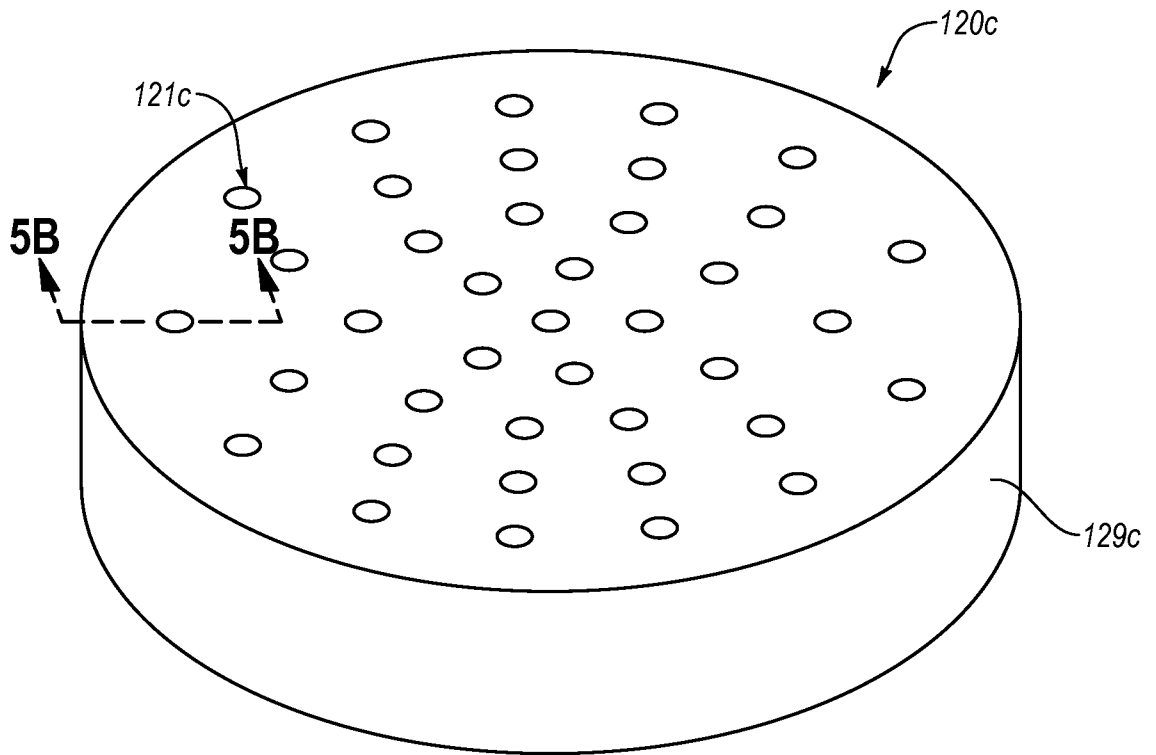
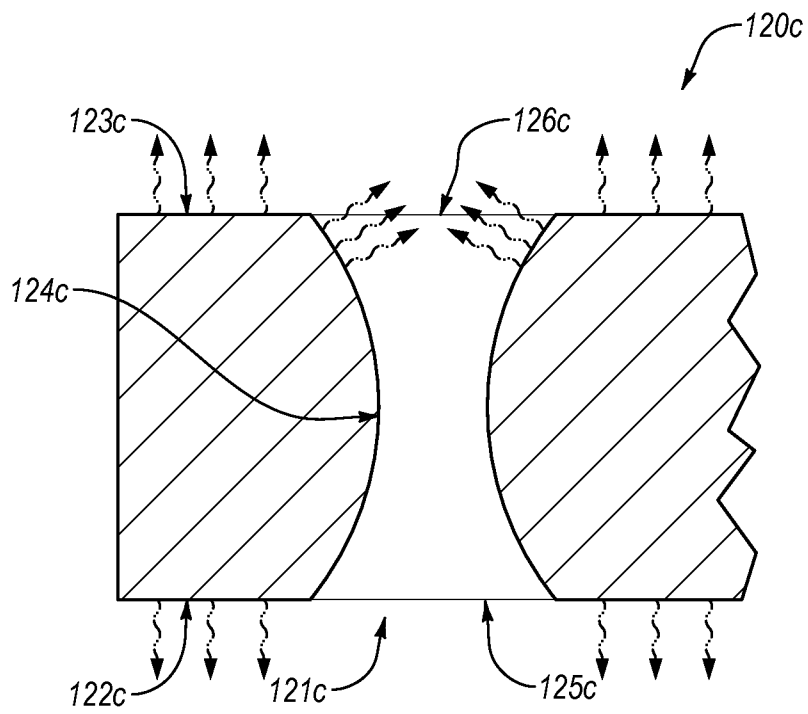

Fig. 4C



**Fig. 5A**



**Fig. 5B**