



- (51) International Patent Classification:
E04H 4/14 (2006.01) F21S 9/04 (2006.01)
F21S 8/00 (2006.01)
- (21) International Application Number:
PCT/GB2009/050168
- (22) International Filing Date:
20 February 2009 (20.02.2009)
- (25) Filing Language: English
- (26) Publication Language: English
- (30) Priority Data:
0803251.8 22 February 2008 (22.02.2008) GB
61/031,028 25 February 2008 (25.02.2008) US
- (71) Applicant and
(72) Inventor: BURNHAM, Douglas [GB/GB]; Woodlands,
Scotchman Lane, Morley, Leeds Yorkshire LS27 0BX
(GB).
- (74) Agents: APPLYEARD LEES et al.; 15 Clare Road, Hal-
ifax, Halifax Yorkshire HX1 2HY (GB).
- (81) Designated States (unless otherwise indicated, for every
kind of national protection available): AE, AG, AL, AM,

AO, AT, AU, AZ, BA, BB, BG, BH, BR, BW, BY, BZ, CA, CH, CN, CO, CR, CU, CZ, DE, DK, DM, DO, DZ, EC, EE, EG, ES, FI, GB, GD, GE, GH, GM, GT, HN, HR, HU, ID, IL, IN, IS, JP, KE, KG, KM, KN, KP, KR, KZ, LA, LC, LK, LR, LS, LT, LU, LY, MA, MD, ME, MG, MK, MN, MW, MX, MY, MZ, NA, NG, NI, NO, NZ, OM, PG, PH, PL, PT, RO, RS, RU, SC, SD, SE, SG, SK, SL, SM, ST, SV, SY, TJ, TM, TN, TR, TT, TZ, UA, UG, US, UZ, VC, VN, ZA, ZM, ZW.

(84) Designated States (unless otherwise indicated, for every kind of regional protection available): ARIPO (BW, GH, GM, KE, LS, MW, MZ, NA, SD, SL, SZ, TZ, UG, ZM, ZW), Eurasian (AM, AZ, BY, KG, KZ, MD, RU, TJ, TM), European (AT, BE, BG, CH, CY, CZ, DE, DK, EE, ES, FI, FR, GB, GR, HR, HU, IE, IS, IT, LT, LU, LV, MC, MK, MT, NL, NO, PL, PT, RO, SE, SI, SK, TR), OAPI (BF, BJ, CF, CG, CI, CM, GA, GN, GQ, GW, ML, MR, NE, SN, TD, TG).

Published:
— with international search report (Art. 21(3))

(54) Title: A GENERATOR

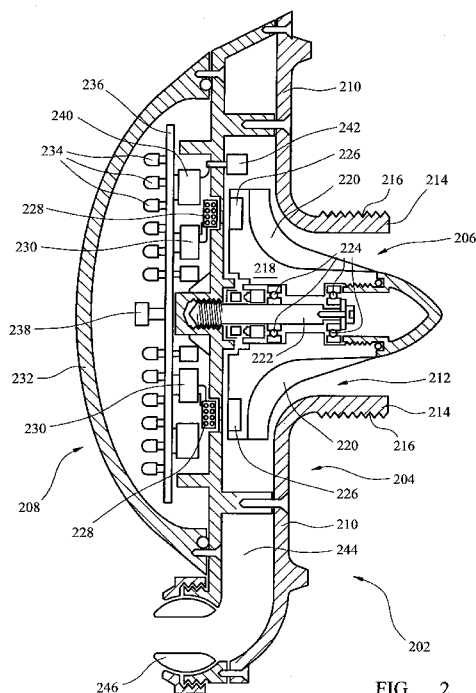

(57) Abstract: A swimming pool water inlet generator (202) comprising attachment means operable to allow the generator to be attached to a swimming pool water inlet, a turbine assembly (205) arranged and operable to generate electricity when water flows through the inlet and at least one electrically powered device (234) operable to use the generated electricity in the operation thereof.

WO 2009/104020 A1

A Generator

The present invention relates to a generator, particularly to a swimming pool water inlet/outlet generator, a kit for retrofitting such a generator to a swimming pool water inlet/outlet and a method of generation.

It is known to provide electrical devices in and around swimming pools. For example, it is known to provide submerged lighting devices to illuminate the water and provide a decorative effect as well as an increased safety aspect.

A problem with the provision of electrical devices in and around swimming pools lies in the provision of a supply of electricity. Health and safety concerns are paramount where water and electricity are used in such proximity meaning that the electricity supply must be very carefully installed using various water tight components. This can be time consuming and expensive.

Swimming pools require that the water therein is treated to prevent the build up of bacteria and algae. Such water treatment is often achieved by pumping an amount of swimming pool water from the pool through a water treatment facility, which may be remote from the swimming pool, before returning the treated water to the pool.

It is an object of aspects of the present invention to address the above mentioned problems and to provide one or more solutions.

According to a first aspect of the present invention there is provided a swimming pool water inlet generator comprising attachment means operable to allow the generator to be attached to a swimming pool water inlet, a
5 turbine assembly arranged and operable to generate electricity when water flows through the inlet and at least one electrically powered device operable to use the generated electricity in the operation thereof.

10 In one embodiment, the electrically powered device may be removably attachable to the generator. In such a scenario, the electrically powered device may be operable to draw power from the generator by means of a plug and socket arrangement, which may be via inductive coupling,
15 for example, or by other means of charge transfer. The electrically powered device may be secured to the generator via securing means, such as clips, for example.

Accordingly, according to a further aspect of the present
20 invention there is provided a swimming pool water inlet generator assembly, the assembly comprising, a turbine assembly arranged and operable to generate electricity when water flows therethrough, the turbine assembly being in electrical communication with at least one electrically
25 powered device, the electrically powered device being operable to use the generated electricity in the operation thereof.

The invention also extends to a turbine assembly
30 comprising one or more coupling means, being operable to allow the turbine assembly to be in electrical communication with one or more electrically powered device; and, separately, to an electrically powered device

comprising coupling means operable to allow the electrically controlled device to be in electrical communication with a turbine assembly.

- 5 By the term "in electrical communication" it is meant that electrical charge generated by the generator is able to be transferred to the electrically powered device.

Preferably, the attachment means is operable to allow the
10 generator to attach to an insert of a swimming pool water inlet. Preferably, the attachment means comprises a threaded region operable to threadedly engage with a threaded region of the swimming pool water inlet.

- 15 The generator may further comprise locking means operable to allow the generator to be locked in position with respect to the swimming pool water inlet. Preferably, the locking means prevent the attachment means becoming unattached.

20

The turbine assembly may comprise a rotor, which may be arranged to rotate when water flows through the swimming pool water inlet. The axis of rotation of the rotor may be generally parallel with the direction of flow of the
25 water through the swimming pool water inlet. Alternatively, the axis of rotation of the rotor may be generally perpendicular with the direction of flow of the water through the swimming pool water inlet. The rotor may be generally conical, preferably having an apex
30 thereof extending into the swimming pool water inlet. The rotor may comprise a generally flat underside, which may be circular in shape. Toward an edge or edges of an underside of the rotor may be located one or more magnets.

The rotor may be arranged on a shaft. The rotor may be free to rotate about the shaft. The rotor may comprise one or more rotor blades or vanes. The blade profiles of the rotor may be different to each other or may be variable. The rotor blades or vanes may be configured such that water exiting the rotor is directed tangentially to the direction of rotation, thus preferably, the exit of water out of the rotor serves to give further propulsion to the rotor. Preferably, the rotor blades or vanes are curved.

The turbine assembly may comprise a braking system which may be operable to allow the rotor to be locked in position and thus rotation thereof to be prevented. In one embodiment, such a braking system may comprise a rod, operable to extend between the rotor and the static portion to thereby lock the two together. The braking system may be manually locally controllable or by means of a remote control.

Alternatively or additionally, the generator may comprise diverting means operable to selectively divert water into or away from the rotor of the turbine assembly.

The turbine assembly may comprise a static portion, upon which may be situated one or more stators. The stators may be arranged on the static portion to correspond with the position of the one or more magnets on the rotor.

The static portion may further comprise one or more electronic components associated with the turbine assembly, such components include: batteries; battery

control units; generator control units; master control units etc.

Preferably, the static portion is generally water tight.

5 Such water tightness may be achieved by rubber seals etc.

The at least one electrically powered device may be fitted to the static portion of the turbine assembly.

10 The electrically powered device may be selected from one or more of the following: a light source; an ionizer; a water heating element; a water cooling element; a salt generator. The electrically powered device preferably comprises a light source, such as an LED or an array of
15 LEDs, but other known light sources are also included within the scope of the invention. The light source may be arranged to provide colour changing lighting effects. Other electrically controlled devices as discussed herein may be used and many further possible electrically
20 controlled devices would be well known and appreciated to a person skilled in the art and are within the scope of the present invention.

The generator may comprise one or more status indicators.

25 The status indicators may be visible or audible. For example, the generator may comprise a light source which illuminates to indicate ready status or poor battery status, for example.

30 Cooling means may be provided to cool elements where required. For example, a heat sink may be provided to cool LEDs, which may function as a heat exchange between the hot component and the relatively cool pool water.

The generator may comprise flow restriction means, which may be a flow restriction member. The flow restriction means may be arranged to restrict the flow of fluid
5 through the inlet, thereby, preferably being operable to cause acceleration of fluid into the turbine assembly.

In a preferred embodiment, the flow restriction member is removably attachable to the generator.

10

Advantageously, a user may regulate the flow of fluid into the turbine assembly to thereby maximise the efficiency of the generator by attaching the flow restriction member.

15 The flow restriction means may be expandable. The expandable flow restriction means may comprise spring and/or lever arrangements and may be operable to expand/contract as a function of rotational speed of the turbine. For example, the expandable flow restriction
20 means may use centrifugal force to expand/contract.

The generator may comprise exhaust direction means, operable to direct the flow of exhaust fluid, the fluid having exited the rotor. The exhaust direction means may
25 comprise a channel or conduit. The exhaust direction means may direct the flow of exhausted fluids to a directionally adjustable outlet.

The generator may comprise a cover portion which may be
30 transparent, translucent or opaque.

The generator may comprise signal detecting means operable to detect a signal from a remote control device.

The generator may comprise light detection means operable to detect levels of light at or around the generator. The light detection means may be arranged to cause the operation of one or more of the electronically powered devices depending on the detected light levels. For example, the light detection means may be arranged to turn an electrically powered light of the generator on when low light is detected, and/or to turn a water heating element on when a high light level is detected etc.

The generator may comprise switching means operable to switch the or each electrically powered device between an on and off position. The switching means may one or more comprise manual switches. The switching means may operate remotely, for example by operation of a remote control unit. The switching means may comprise a timer which may allow the or each (separately or together) electrically powered devices to be switched on or off at a predetermined time. The timer may be programmable, preferably by a remote control unit.

Reference herein to a swimming pool water inlet should be understood as reference to an inlet or outlet, that is, an orifice that allows water into or out of a swimming pool. However, in a preferred embodiment, a swimming pool water inlet should be understood as an orifice that allows water into a swimming pool.

The present invention extends to a submergible swimming pool light which is attachable to a swimming pool water inlet, the light comprising an integral electricity generator to power the said light.

According to a further aspect of the present invention there is provided a swimming pool water inlet generator assembly, the assembly comprising a swimming pool water inlet having attached thereto a swimming pool water inlet generator comprising attachment means operable to allow the generator to be attached to a swimming pool water inlet, a turbine assembly arranged and operable to generate electricity when water flows through the inlet and at least one electrically powered device operable to use the generated electricity in the operation thereof.

The assembly may comprise flow restriction means.

According to a further aspect of the present invention there is provided a method of generation, the method comprising arranging a swimming pool water inlet generator about a swimming pool water inlet such that water passing through the said inlet is caused to enter a turbine assembly of the swimming pool water inlet generator causing the generation of electricity, which electricity may be used to power at least one electrically powered device of the swimming pool water inlet generator.

The method may comprise restricting the flow of fluid into the generator with flow restriction means.

According to a further aspect of the present invention there is provided a method of attaching a swimming pool water inlet generator to a swimming pool water inlet, the method comprising using attachment means of the swimming pool water inlet generator to attach the generator to the swimming pool water inlet, and arranging a turbine

assembly of the generator relative to the swimming pool water inlet such that water passing through the inlet enters the turbine assembly.

- 5 Other optional features/uses of the generator device are as follows. The generator could be used in swimming pools (indoor or outdoor), spas, lakes or fountains.

The generator may comprise flow detection means operable
10 to detect a flow of fluid through the inlet. The flow detection means may operate by monitoring the voltage output of the generator. Such a function may be used to inhibit or regulate water treatment function, for example, to prevent inappropriate device operation.

15

The generator may comprise water testing means. For example, probes arranged to be exposed to the water (proximal to the turbine, for example) may be operable to communicate with the auxiliary devices various parameters
20 of the water. For example, parameters such as chlorine content etc. could be monitored and relayed to auxiliary devices (such as a water treatment facility). The generator could comprise temperature sensing means to measure the temperature of the pool water through the
25 inlet. Further, the generator could be arranged to illuminate different lights depending on the temperature of the water through the generator.

The generator may comprise an alarm facility. The alarm
30 facility may comprise sensors or cameras to detect people present in the pool. Upon detection of unauthorised swimmers, a signal could be sent to an auxiliary source (such as an audible alarm). Alternatively or

additionally, in an alarm condition, the generator could be arranged to trigger an alarm lighting condition (flashing red LEDs for example).

5 The pool inlet could project out of the body of water. For example, the inlet could be a fountain head. The generator may comprise one or more outlet to allow the water to flow out of the generator. The outlet may comprise numerous apertures and may independently be
10 directionally adjustable.

All of the features disclosed herein may be combined with any of the above aspects in any combination.

15 For a better understanding of the invention, and to show how embodiments of the same may be carried into effect, reference will now be made, by way of example, to the accompanying diagrammatic drawings in which:

20 Figure 1 shows a cross sectional view of a prior art swimming pool water inlet;

Figure 2 shows a cross sectional view of a swimming pool inlet generator device of the present invention;

25

Figure 3 shows an alternative embodiment of the device of figure 2 attached to a swimming pool water inlet;

30 Figure 4 shows an alternate manner of fitting the generator device of figure 3 to a swimming pool water inlet;

Figure 5 shows a cross sectional view of a further embodiment of a swimming pool inlet generator device of the present invention.; and

5 Figure 6 shows a partial sectional view of a third embodiment of a swimming pool inlet generator device having a separately attachable lighting module.

Referring first to figure 1 there is shown a swimming pool
10 water inlet 102 of the prior art. The water inlet is in the wall 104 of a swimming pool 106 at a submerged position. The water inlet 102 is connected to a water treatment facility (not shown) via a conduit 108. The arrows in the conduit show the direction of water flow
15 therethrough. At the junction between the conduit 108 and the wall 104 is an insert 110 which has an interior portion 112 and an exterior portion 114. The interior portion 112 is tubular and extends into an aperture in the pool wall 104. Attached to an end of the interior portion
20 112 is an exterior portion 114 which comprises a flange 115 which abuts the outer surface of the wall 104. The insert 110 has an internal thread 113 therein to allow devices to be attached thereto. One such device is a diffuser 116, as shown in figure 1. The diffuser serves
25 two purposes in that it restricts the flow of water through the inlet, thus increasing the back pressure in the system (which is necessary for some pool apparatus, such as some pressure sensing heat controls, for example) and it directs and diffuses water entering the pool.

30

Referring now to figure 2 there is shown a swimming pool inlet generator device 202 of the present invention. The generator 202 comprises a rear portion 204 adapted to be

screwed into an insert (such as insert 110, described above), a turbine assembly 206 and a display portion 208.

The rear portion 204 comprises a generally circular plate 5 210 having a circular aperture 212 at the diametric centre thereof. Extending axially from the circumferential edge of the aperture 212 is a short tube 214 having an external threaded portion 216. The external thread allows the device to be screwed into an insert (such as the insert 10 110) as will be described below in relation to figure 3.

Attached to a front face of the rear portion 204 is the display portion 208, which houses the turbine assembly 206. The turbine assembly 206 comprises a rotatable rotor 15 218, operable to rotate under a flow of water therethrough. The rotor 218 comprises rotor blades 220 and is mounted on, and arranged to freely rotate with respect to, a shaft 222 via bearings 224. The rotor 218 is generally bell shaped having a flat underside and 20 tapering up to an apex distal to the display portion 208. Mounted in the flat underside of the rotor 218 are magnets 226. Arranged opposite the magnets 226 in the stationary housing of the display portion are stators 228 connected to batteries 230. Rotation of the rotor 218 causes 25 rotation of the magnets 226 relative to the stators 228, thus the device form an electricity generator, providing electricity to charge the batteries 230 in a manner well known in the art.

30 The display portion 208 comprises an outwardly facing transparent domed cover 232, which covers an array of LEDs 234 attached to a board 236. The LEDs draw power from the batteries 230 to produce light, when required. The board

236 also houses a sensor 238, operable to receive a signal from a remote control device to thereby control the LEDs and other electrical devices, such as an ioniser (shown in figure 2 as 240 ioniser control and 242 ioniser electrodes). The device 202 is also fitted with usual components to enable the electrical generation such as generator control, battery control and master control.

The device 202 further comprises a conduit 244 leading from the rotor to a diffuser 246 at a position below the display portion 208 which allows water to enter the pool (not shown) in the usual manner similar to that described above in relation to figure 1.

In use, the device is fitted to a swimming pool inlet (as will be described hereunder with relation to figure 3). Water flowing through the inlet into the pool turns the rotor, thus operating the turbine assembly and generating electricity. The electricity generated can be stored in batteries 230 and used to power supplementary devices such as a light source (the LEDs 234) or an ioniser 240, 242. The supplementary devices may be used while the electricity is being generated or at a subsequent time. The device is further provided with a transmitter/receiver to allow it to be controlled remotely using a remote control unit (not shown).

Referring now to figure 3 there is shown a further embodiment of a generator device 302 attached to a swimming pool water inlet. As can be clearly seen in figure 3, the device 302 screws into an internal thread of an insert 110 as described above in relation to figure 1. The arrows in figure 2 show the flow of water through the

conduit 108, through the device 302 and out into the pool 106. The device 302 is the same as the device 202 except that instead of having a conduit and diffuser arrangement as per the conduit 244 and diffuser 246 of figure 2, the
5 water is allowed out into the pool 106 via apertures in the device 304, as shown by the arrows in figure 3.

Figure 4 shows the device 302 attached to a swimming pool in a recessed manner, so that the cover portion is
10 generally flush with the walls 104 of the pool.

Figure 5 shows a further embodiment of a swimming pool inlet generator device 502 fixed to a swimming pool inlet 504, in the wall 506 of a swimming pool via cooperating
15 threads, one thread 508 being on an outer wall of standard swimming pool inlet insert 510, the other thread 512 projecting from a rear side of the device 502. For simplicity, parts of the device have been omitted from Figure 5. For example, Figure 5 does not show any
20 electricity storage means, such as a battery or capacitor. Also, the device displayed in Figure 5 does not show an associated electrically powered device, but such a device (ie. a light, for example) would normally be fitted. Other optional features as discussed herein may also be
25 used with this embodiment of the device.

The device 502 comprises a rotatable rotor 514, which is mounted on a rotatable shaft 515, the rotor 514 extends into the swimming pool inlet 504 and has, affixed to an
30 end thereof that extends into the inlet, a flow regulating member 516. The flow regulating member 516 is generally egg shaped and regulates the flow of fluid into the rotor 514 by creating an obstruction in the inlet 504. The

operation of the flow regulating member 516 will be discussed in more detail hereunder.

The rotatable rotor 514 is operable to rotate by the flow
5 of fluid passing therethrough, as discussed above in relation to the first embodiment. In more detail, the rotor 514 comprises shrouded conduits 518 that allow the flow of fluid therethrough.

10 At a side of the device 502 distal to the inlet 504 is a magnet/stator arrangement to form the turbine. The magnets 520 are arranged circumferentially around the shaft 515 toward an end thereof distal to the flow regulating member 516, while the stator windings 522 are
15 arranged in a circumferential housing 524 and generally surround the magnets 520. The housing 524 is static, in use, while the magnets, being fixed to the shaft 515, rotate, when in use.

20 Different swimming pools may have different powered circulation pumps, different numbers of inlets, and probably both. For this reason, the flow of water through the inlet 504 can differ widely between different swimming pools. For this reason, it is important to be able
25 regulate the flow at the generator device to ensure that the rotor is turning at an efficient rate to generate sufficient electricity. A flow regulating member 516 is operable to address this issue by restricting or allowing the flow of water into the conduits 518. As shown in
30 Figure 5, the flow regulating member restricts the flow of fluid into the conduits 518, thereby causing the fluid to accelerate and thus the rotor to spin faster. In this manner, the efficiency of the generator 502 is increased.

The flow regulating device 516 is a removable object and it is envisaged that a user, who may be a swimming pool engineer, may carry several flow regulating devices of differing sizes to maximise the efficiency of the generator depending on the flow rate through the inlet in question.

Referring now to figure 6 there is shown a third embodiment of a swimming pool generator device 602 of the present invention. The device 602 comprises a generator unit 604 and a removably attachable electrically powered device unit 606, being a light.

The generator unit 604 is similar to that described above in relation to figures 2 and 5 and comprises a rotatable rotor 608 having curved rotor blades 610. Extending into a swimming pool inlet 612 is a flow restriction member 614, being similar in form and function to that described above in relation to figure 5. The generator unit 604 also comprises an outlet unit 616. The rotor 608 is designed to direct exhausted fluid (water) into the outlet unit 616, which then channels the water through a directionally adjustable outlet 618. The magnet and stator arrangement 620 of the unit 604 is similar to that described above in relation to figure 2.

Toward a lower portion of the unit 604 is a plug arrangement 621, operable to allow a electrically powered device module to be plugged thereon, such as the electrically powered device module 606, being a lighting module. The lighting module 606 comprises a battery and control sensors 622, an LED lighting array 624 situated

behind a lens 626. The interface between the generator unit 604 and the lighting module 606 (a plug and socket arrangement) in the present embodiment comprises an inductive coupling arrangement operable to transfer charge
5 from the generator unit 604 to the lighting unit 606 (and ultimately to the battery 622). The inductive coupling arrangement functions in a manner well known in the art. The electrical coupling is established by locating the lighting unit 606 adjacent the generator unit 604 as shown
10 by arrows "X" on figure 6. Other arrangements are envisaged and are within the scope of the present invention such as a traditional plug and socket (charge conducted by contact, for example through metallic connections). The lighting unit is secured to the
15 generator unit 604 by securing clips (not shown).

It will be appreciated by one skilled in the art that any of the electrically powered devices as described herein may be attached to the generator unit 604. Further, a
20 generator unit as described above may have a plurality of plug arrangements to allow more than one electrically powered device to be fitted therewith. In an alternative embodiment, the electrically powered device module may allow further devices to be attached to it. For example,
25 a temperature probe module may be fitted to (and draw electrical charge from) an adjacent lighting module, which may in turn be fitted to (and draw electrical charge from) a generator unit, such as the generator unit 604.

30 It will also be appreciated that the manner of exhausting the water from the generator unit as shown in figure 6 could be altered to direct it through an adjacent electrically controlled device unit. For example, in the

case where the electrically controlled device is a water treatment device (an ioniser, for example). Further, the electrically controlled device unit may be removably attachable to the front of the generator unit, or at any point around the periphery.

It will be appreciated, as discussed above, that the generator may be used to power other swimming pool devices such as an ioniser, heating element, cooling element etc.

10

The generator may be controlled by means of a remote control unit, such as an infra red or radio frequency controller. The generator may also have timing functions to allow a user to set the time at which the electrically powered item turns on/off. The generator may also comprise light detection means, such as an LDR. The light detection means may be local to the generator, ie. located within the housing thereof, or may be remote ie. thereby operable to detect the light conditions at the surface of the pool, rather than at a submerged position.

20

A generator according to the present invention is easy to install to an existing insert and thus requires little or no modification to existing pool inlets to fit. Further, the device negates the need to supply cables to submerged pool apparatus, such as lights. This represents a beneficial safety feature as well as a saving of time and money. The generator of the present invention provides a self contained submergible electrically powered device having an integral means of power generation which is economically and environmentally favourable.

30

It will be apparent to a person skilled in the art that the swimming pool water inlet generator could be used for pools (indoor or outdoor), spas, lakes or fountains, all being within the scope of the present invention.

5

Attention is directed to all papers and documents which are filed concurrently with or previous to this specification in connection with this application and which are open to public inspection with this
10 specification, and the contents of all such papers and documents are incorporated herein by reference.

All of the features disclosed in this specification (including any accompanying claims, abstract and
15 drawings), and/or all of the steps of any method or process so disclosed, may be combined in any combination, except combinations where at least some of such features and/or steps are mutually exclusive.

Each feature disclosed in this specification (including any accompanying claims, abstract and drawings) may be replaced by alternative features serving the same, equivalent or similar purpose, unless expressly stated
20 otherwise. Thus, unless expressly stated otherwise, each feature disclosed is one example only of a generic series of equivalent or similar features.

The invention is not restricted to the details of the foregoing embodiment(s). The invention extends to any
30 novel one, or any novel combination, of the features disclosed in this specification (including any accompanying claims, abstract and drawings), or to any

novel one, or any novel combination, of the steps of any method or process so disclosed.

CLAIMS

1. A swimming pool water inlet generator comprising
5 attachment means operable to allow the generator to be
attached to a swimming pool water inlet, a turbine
assembly arranged and operable to generate electricity
when water flows through the inlet and at least one
electrically powered device operable to use the generated
10 electricity in the operation thereof.

2. A swimming pool water inlet generator according to
claim 1, wherein the attachment means is operable to allow
the generator to attach to an insert of a swimming pool
15 water inlet.

3. A swimming pool water inlet generator according to
either of claim 1 or claim 2, wherein the attachment means
comprises a threaded region operable to threadedly engage
20 with a threaded region of a swimming pool water inlet.

4. A swimming pool water inlet generator according to any
preceding claim, wherein the generator further comprise
locking means operable to allow the generator to be locked
25 in position with respect to the swimming pool water inlet.

5. A swimming pool water inlet generator according to any
preceding claim, wherein the turbine assembly comprises a
rotor, which is arranged to rotate when water flows
30 through the swimming pool water inlet.

6. A swimming pool water inlet generator according to
claim 5, wherein the axis of rotation of the rotor is

parallel with the direction of flow of the water through the swimming pool water inlet.

7. A swimming pool water inlet generator according to claim 5 or 6, wherein the rotor is generally conical, having an apex thereof extending into the swimming pool water inlet.

8. A swimming pool water inlet generator according to any preceding claim, wherein the turbine assembly comprises a braking system which is operable to allow the rotor to be locked in position and thus rotation thereof to be prevented.

9. A swimming pool water inlet generator according to any preceding claim, wherein the generator comprises diverting means operable to selectively divert water into or away from the rotor of the turbine assembly.

10. A swimming pool water inlet generator according to any preceding claim, wherein the turbine assembly comprises a static portion, upon which may be situated one or more stators.

11. A swimming pool water inlet generator according to claim 10, wherein the static portion further comprise one or more electronic components associated with the turbine assembly, such components being selected from one or more of: batteries; battery control units; generator control units; master control units etc.

30

12. A swimming pool water inlet generator according to either of claim 10 or claim 11, wherein the static portion is generally water tight.

13. A swimming pool water inlet generator according any of
claims 10 to 12, wherein the at least one electrically
powered device is fitted to the static portion of the
5 turbine assembly.

14. A swimming pool water inlet generator according to any
preceding claim, wherein the electrically powered device
is selected from one or more of the following: a light
10 source; an ionizer; a water heating element; a water
cooling element.

15. A swimming pool water inlet generator according to
claim 14, wherein the electrically powered device
15 comprises a light source, such as an LED or an array of
LEDs.

16. A swimming pool water inlet generator according to any
preceding claim, which comprises one or more status
20 indicators.

17. A swimming pool water inlet generator according to any
preceding claim, which comprises a cover portion that may
be transparent, translucent or opaque.
25

18. A swimming pool water inlet generator according to any
preceding claim, which comprises signal detecting means
operable to detect a signal from a remote control device.

30 19. A swimming pool water inlet generator according to any
preceding claim, which comprises light detection means
operable to detect levels of light at or around the
generator.

20. A swimming pool water inlet generator according to claim 19, wherein the light detection means is arranged to cause the operation of one or more of the electronically
5 powered devices depending on the detected light levels.

21. A swimming pool water inlet generator according to any preceding claim, which comprises switching means operable to switch the or each electrically powered device between
10 an on and off position.

22. A swimming pool water inlet generator according to claim 21, wherein the switching means comprises a timer that allows the or each (separately or together)
15 electrically powered devices to be switched on or off at a predetermined time.

23. A submergible swimming pool light which is attachable to a swimming pool water inlet, the light comprising an
20 integral electricity generator to power the said light.

24. A swimming pool water inlet generator assembly, the assembly comprising a swimming pool water inlet having attached thereto a swimming pool water inlet generator
25 comprising attachment means operable to allow the generator to be attached to a swimming pool water inlet, a turbine assembly arranged and operable to generate electricity when water flows through the inlet and at least one electrically powered device operable to use the
30 generated electricity in the operation thereof.

25. A method of generation, the method comprising arranging a swimming pool water inlet generator about a

swimming pool water inlet such that water passing through the said inlet is caused to enter a turbine assembly of the swimming pool water inlet generator causing the generation of electricity, which electricity may be used
5 to power at least one electrically powered device of the swimming pool water inlet generator.

26. A method of attaching a swimming pool water inlet generator to a swimming pool water inlet, the method
10 comprising using attachment means of the swimming pool water inlet generator to attach the generator to the swimming pool water inlet, and arranging a turbine assembly of the generator relative to the swimming pool water inlet such that water passing through the inlet
15 enters the turbine assembly.

27. A swimming pool water inlet generator substantially as hereinbefore described and with reference to the accompanying figures.
20

28. A swimming pool water inlet generator assembly substantially as hereinbefore described and with reference to the accompanying figures.

25 29. A method of generation substantially as hereinbefore described and with reference to the accompanying figures.

30. A method of attaching a swimming pool water inlet generator to a swimming pool water inlet as hereinbefore
30 described and with reference to the accompanying figures.

FIG. 1
PRIOR ART

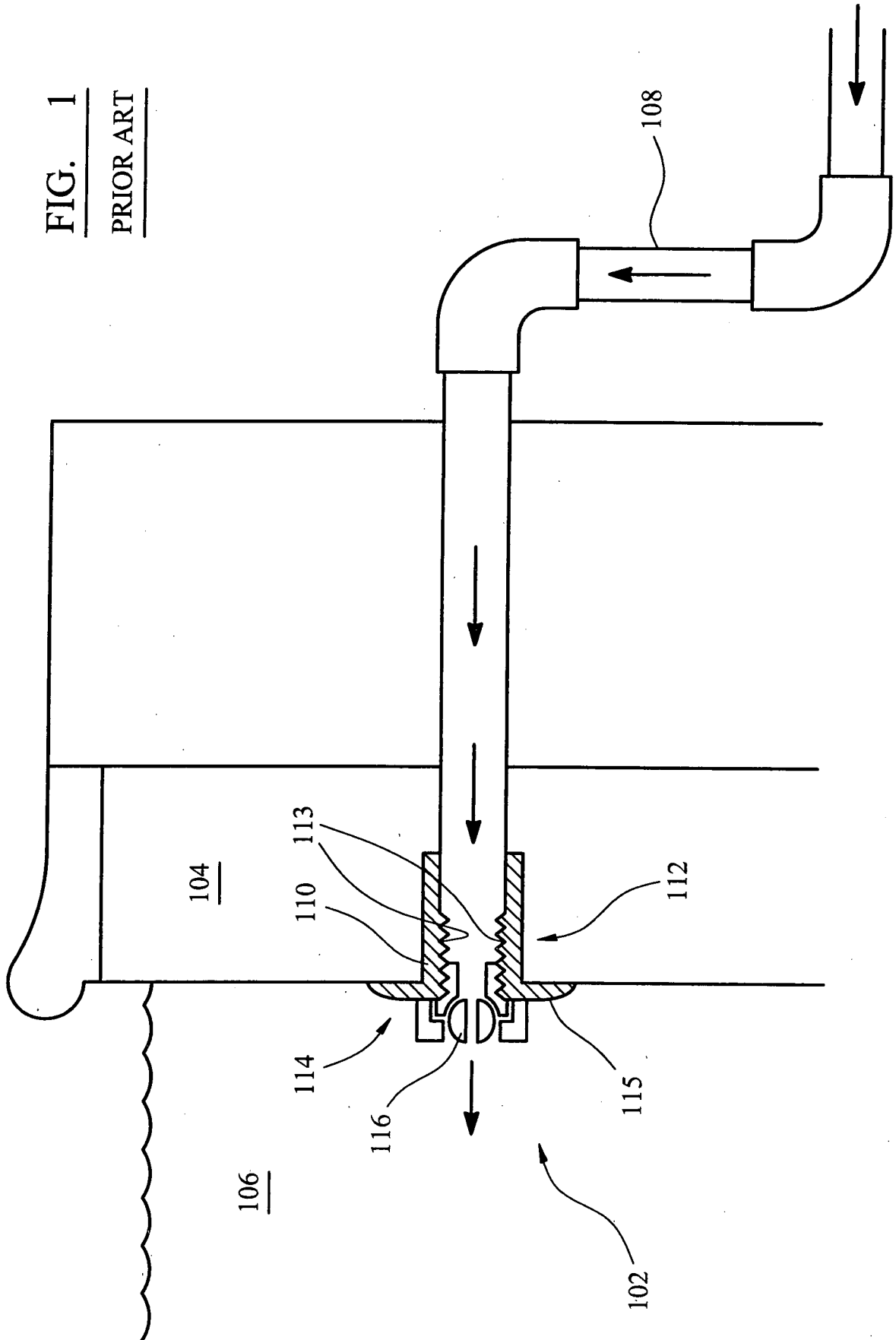

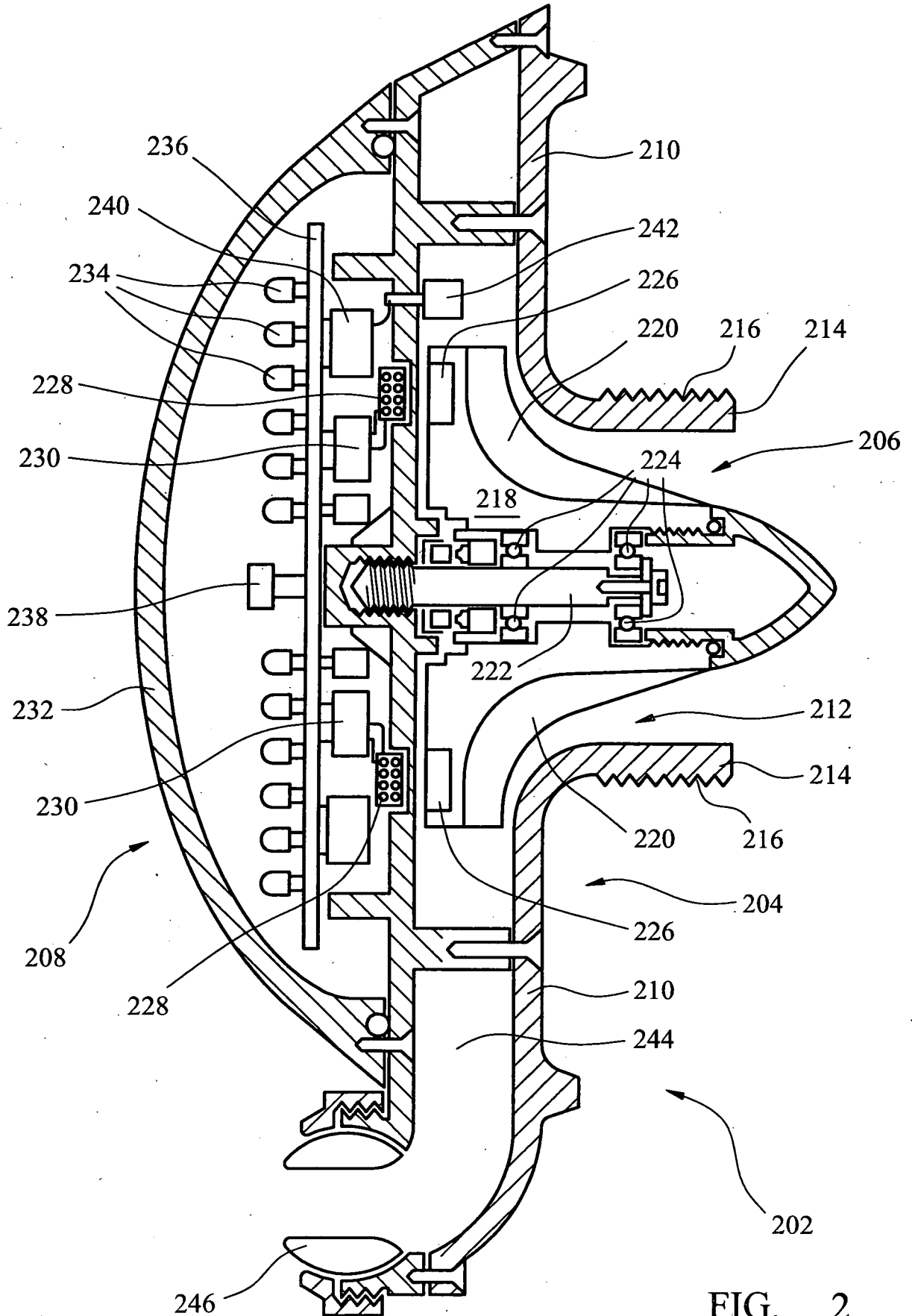

FIG. 2

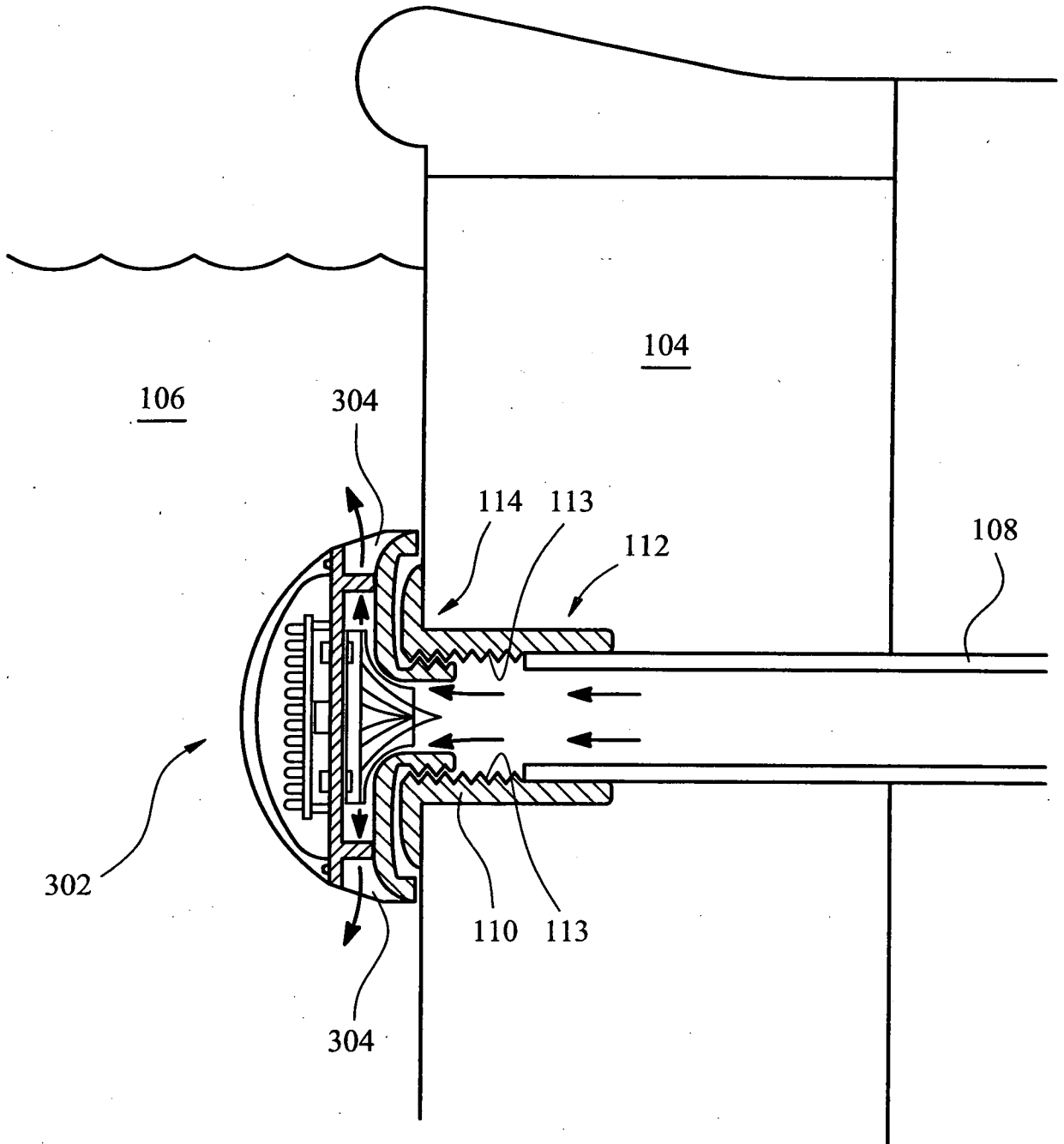

FIG. 3

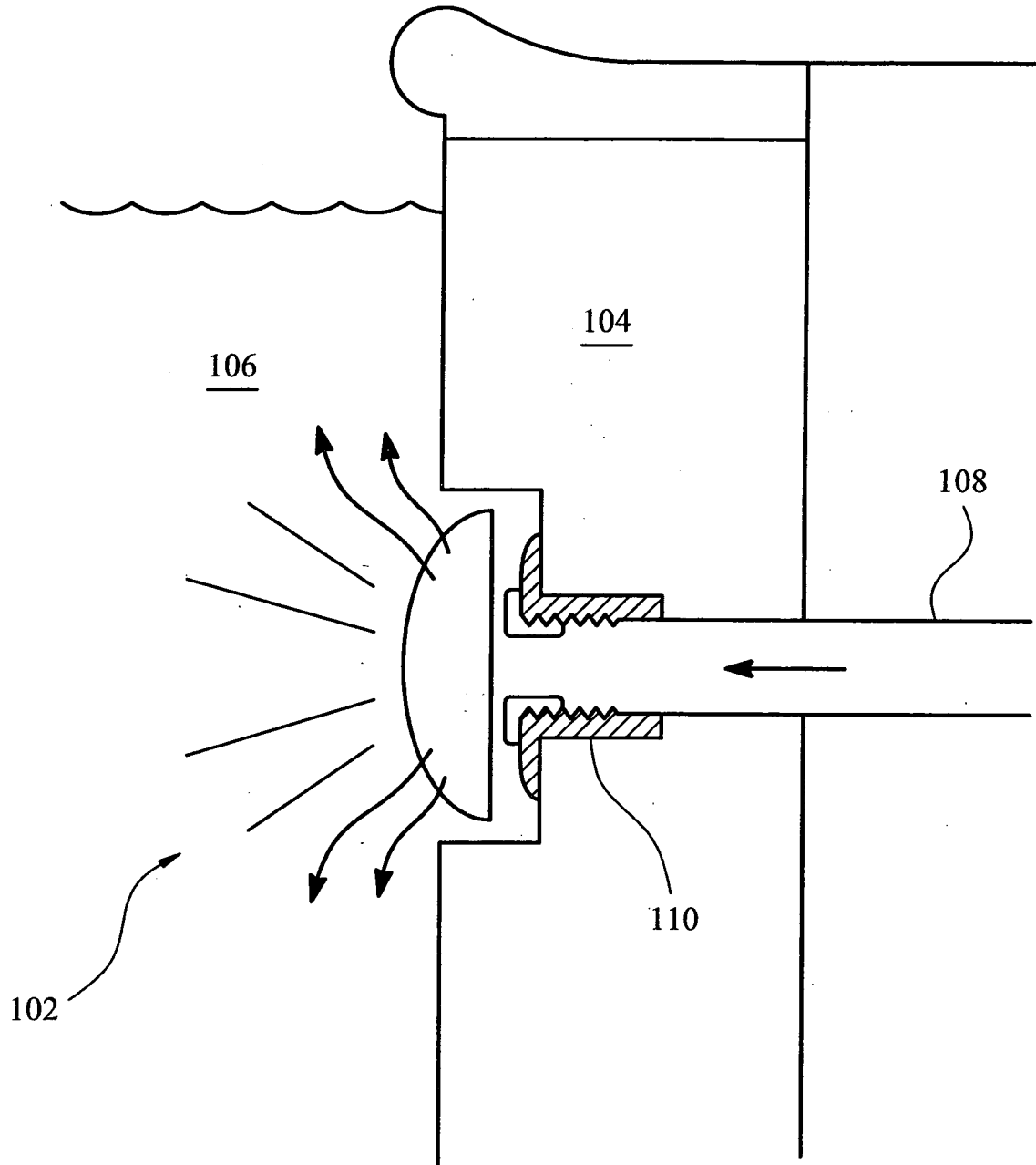

FIG. 4

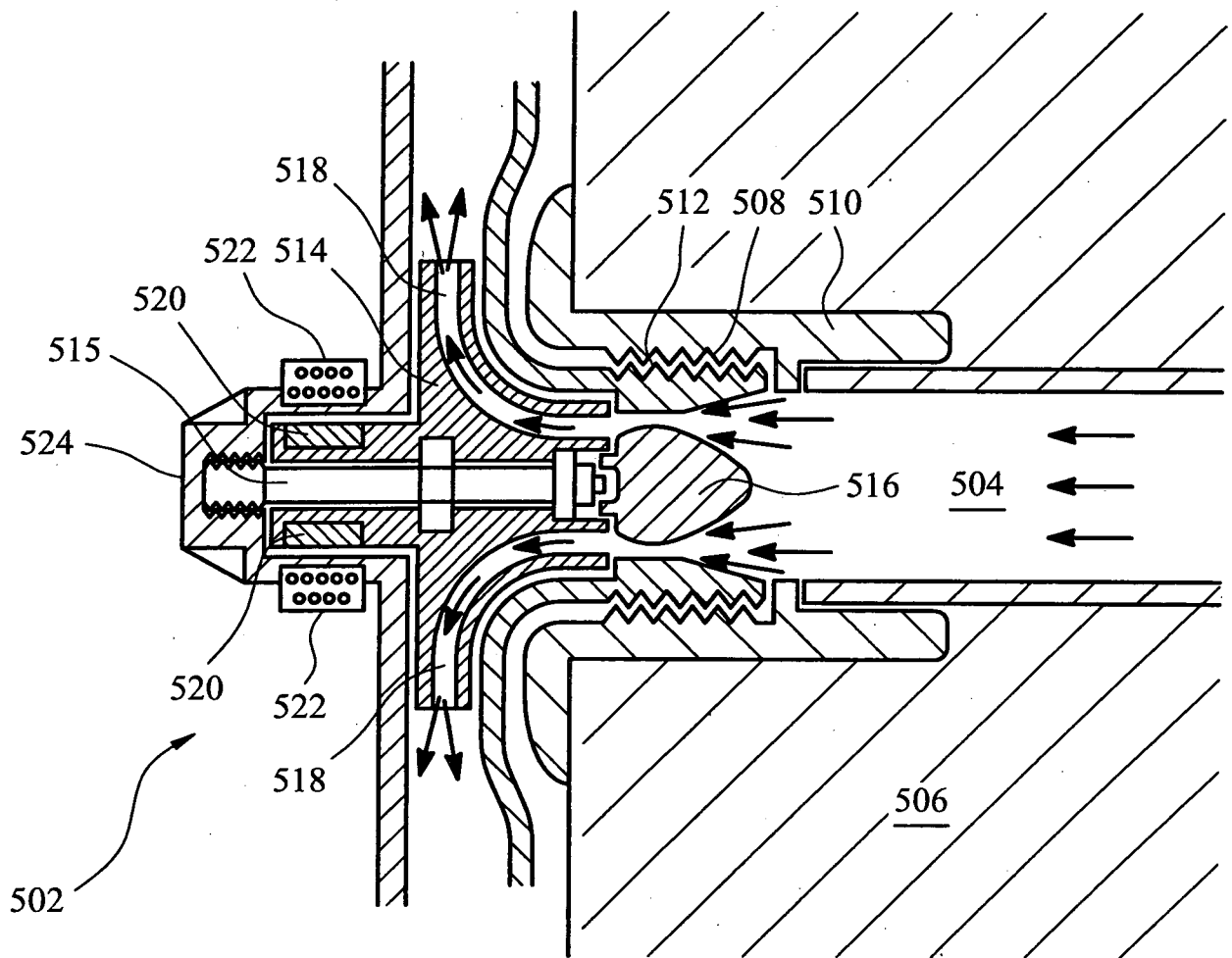

FIG. 5

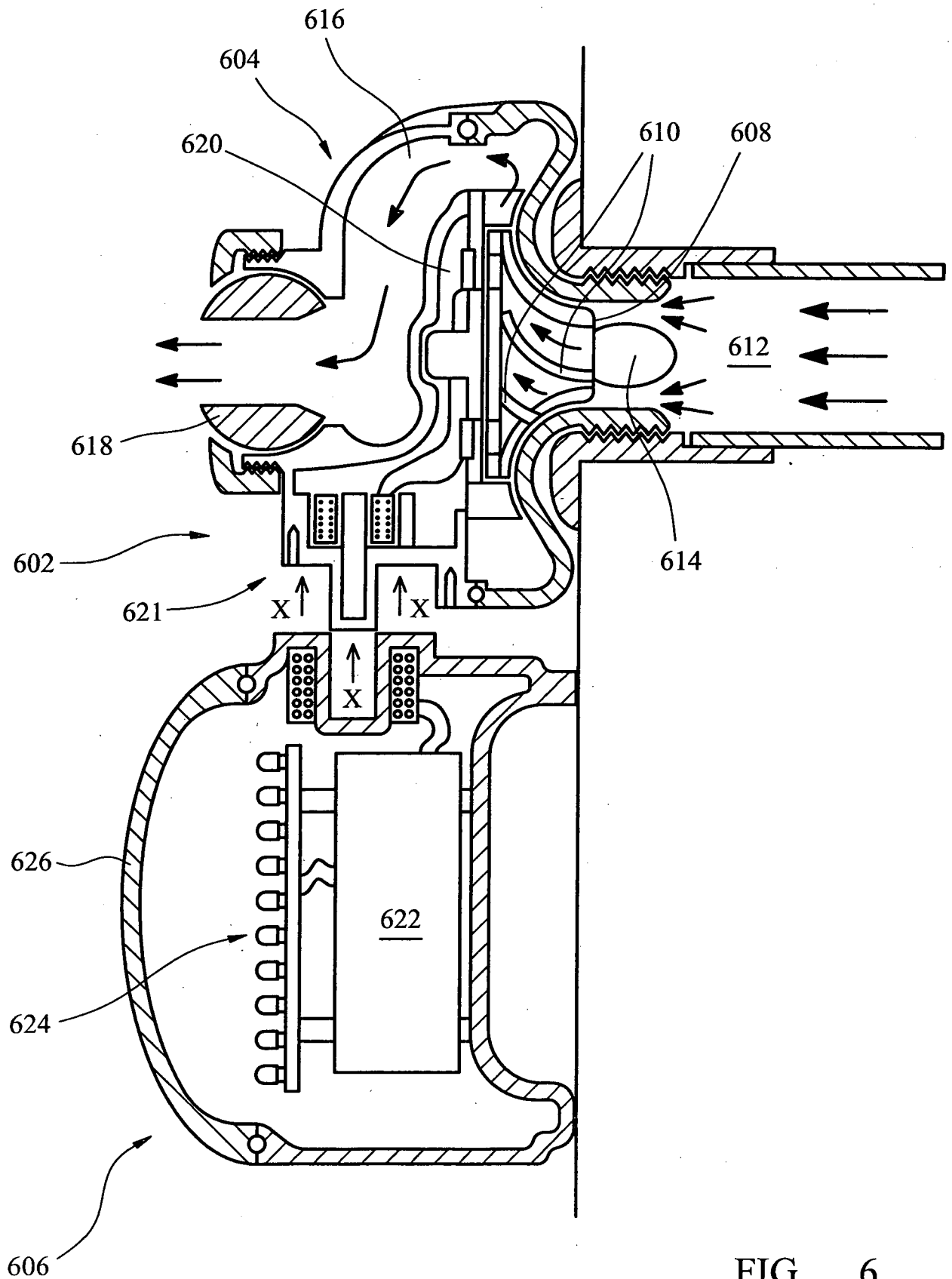

FIG. 6

INTERNATIONAL SEARCH REPORT

International application No
PCT/GB2009/050168

A. CLASSIFICATION OF SUBJECT MATTER
INV. E04H4/14 F21S8/00 F21S9/04

According to International Patent Classification (IPC) or to both national classification and IPC

B. FIELDS SEARCHED

Minimum documentation searched (classification system followed by classification symbols)
E04H F21S

Documentation searched other than minimum documentation to the extent that such documents are included in the fields searched

Electronic data base consulted during the international search (name of data base and, where practical, search terms used)

EPO-Internal, WPI Data

C. DOCUMENTS CONSIDERED TO BE RELEVANT

Category*	Citation of document, with indication, where appropriate, of the relevant passages	Relevant to claim No.
X	US 4 616 298 A (BOLSON FRANK J [US]) 7 October 1986 (1986-10-07)	1-6, 8, 10-17, 23-30
Y	figures 1,5,11 column 1, line 45 - line 66 column 2, line 45 - line 54 column 3, line 1 - line 5 column 3, line 9 - line 22 column 3, line 30 - line 48 column 4, line 3 - line 5 column 4, line 22 - line 24 ----- -/--	18-22

Further documents are listed in the continuation of Box C.

See patent family annex.

* Special categories of cited documents :

- *A* document defining the general state of the art which is not considered to be of particular relevance
- *E* earlier document but published on or after the international filing date
- *L* document which may throw doubts on priority claim(s) or which is cited to establish the publication date of another citation or other special reason (as specified)
- *O* document referring to an oral disclosure, use, exhibition or other means
- *P* document published prior to the international filing date but later than the priority date claimed

- *T* later document published after the international filing date or priority date and not in conflict with the application but cited to understand the principle or theory underlying the invention
- *X* document of particular relevance; the claimed invention cannot be considered novel or cannot be considered to involve an inventive step when the document is taken alone
- *Y* document of particular relevance; the claimed invention cannot be considered to involve an inventive step when the document is combined with one or more other such documents, such combination being obvious to a person skilled in the art.
- *Z* document member of the same patent family

Date of the actual completion of the international search

7 May 2009

Date of mailing of the international search report

15/05/2009

Name and mailing address of the ISA/
European Patent Office, P.B. 5818 Patentlaan 2
NL - 2280 HV Rijswijk
Tel. (+31-70) 340-2040,
Fax: (+31-70) 340-3016

Authorized officer

Brucksch, Carola

INTERNATIONAL SEARCH REPORT

International application No
PCT/GB2009/050168

C(Continuation). DOCUMENTS CONSIDERED TO BE RELEVANT		
Category*	Citation of document, with indication, where appropriate, of the relevant passages	Relevant to claim No.
X	<p>US 3 845 291 A (PORTYRATA R) 29 October 1974 (1974-10-29)</p> <p>figures 2,4 column 8, line 63 - column 9, line 19 column 6, line 12 - line 27 -----</p>	<p>1,2,5-7, 10, 13-17, 23-30</p>
X	<p>AU 649 515 B2 (SAMUEL ROBERT MIDDLEBY) 26 May 1994 (1994-05-26)</p> <p>figure 1 page 6, line 30 - line 36 page 7, line 1 - line 11 page 7, line 27 - line 30 -----</p>	<p>1-5,10, 12-17, 23-30</p>
Y	<p>US 2003/137258 A1 (PIEPGRAS COLIN [US] ET AL) 24 July 2003 (2003-07-24) page 5, paragraph 102 page 5, paragraph 105 page 7, paragraph 120 - page 8 page 8, paragraph 123 -----</p>	<p>18-22</p>

INTERNATIONAL SEARCH REPORT

Information on patent family members

International application No

PCT/GB2009/050168

Patent document cited in search report		Publication date	Patent family member(s)	Publication date
US 4616298	A	07-10-1986	NONE	
US 3845291	A	29-10-1974	NONE	
AU 649515	B2	26-05-1994	AU 1061992 A	13-08-1992
US 2003137258	A1	24-07-2003	NONE	