



US007562430B2

(12) **United States Patent**  
**Waisanen**

(10) **Patent No.:** **US 7,562,430 B2**  
(45) **Date of Patent:** **Jul. 21, 2009**

(54) **PIN CHANGING DEVICE AND METHOD**

(75) Inventor: **Steven K. Waisanen**, Big Bend, WI (US)

(73) Assignee: **MHE Technologies, Inc.**, Wilmington, DE (US)

(\* ) Notice: Subject to any disclaimer, the term of this patent is extended or adjusted under 35 U.S.C. 154(b) by 699 days.

(21) Appl. No.: **11/032,529**

(22) Filed: **Jan. 10, 2005**

(65) **Prior Publication Data**

US 2006/0151764 A1 Jul. 13, 2006

(51) **Int. Cl.**  
*B25B 27/14* (2006.01)  
*B23P 6/00* (2006.01)

(52) **U.S. Cl.** ..... **29/281.5**; 29/252; 29/256; 29/263

(58) **Field of Classification Search** ..... 29/252, 29/256, 257, 258, 259, 260, 261, 262, 263, 29/281.5

See application file for complete search history.

(56) **References Cited**

**U.S. PATENT DOCUMENTS**

3,059,327 A \* 10/1962 Burrows ..... 29/258  
3,427,726 A 2/1969 Fleissner  
4,184,600 A 1/1980 Goss et al.

4,235,004 A \* 11/1980 Floyd ..... 29/256  
4,287,651 A 9/1981 Cilderman et al.  
5,058,256 A \* 10/1991 Taylor et al. .... 29/260  
5,649,635 A 7/1997 Casavant et al.  
6,085,419 A 7/2000 Poitras  
6,266,860 B1 7/2001 Kiebler  
6,748,637 B2 \* 6/2004 Meggiolan ..... 29/257  
7,082,747 B2 \* 8/2006 Oishi et al. .... 59/7  
2007/0193247 A1 \* 8/2007 Daniels et al. .... 59/7

**FOREIGN PATENT DOCUMENTS**

GB 2084502 A \* 4/1982

**OTHER PUBLICATIONS**

International Search Report for International Application No. PCT/US05/01364 dated Jun. 14, 2005.

\* cited by examiner

*Primary Examiner*—Essama Omgba

(74) *Attorney, Agent, or Firm*—Porter, Wright, Morris & Arthur, LLP

(57) **ABSTRACT**

A pin removal assembly for use with an upper block of a crane includes a sheave support and a pin support. The upper block includes a frame, a plurality of sheaves, and a removable sheave pin that defines an axis of rotation for the sheaves and supports the sheaves within the frame. The pin removal assembly includes a sheave support mountable to the frame of the upper block and a pin support mountable to the frame of the upper block. The pin support is configured to support the sheave pin when the sheave pin is removed from the upper block.

**19 Claims, 2 Drawing Sheets**

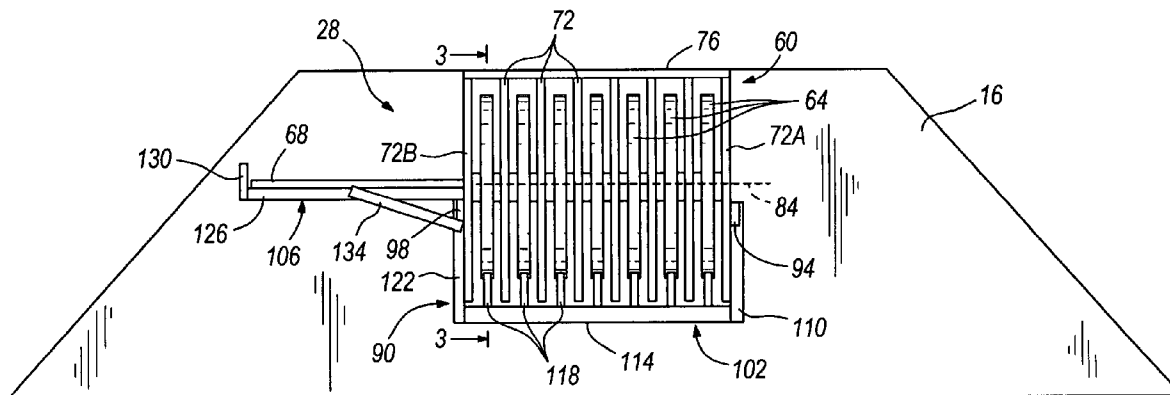

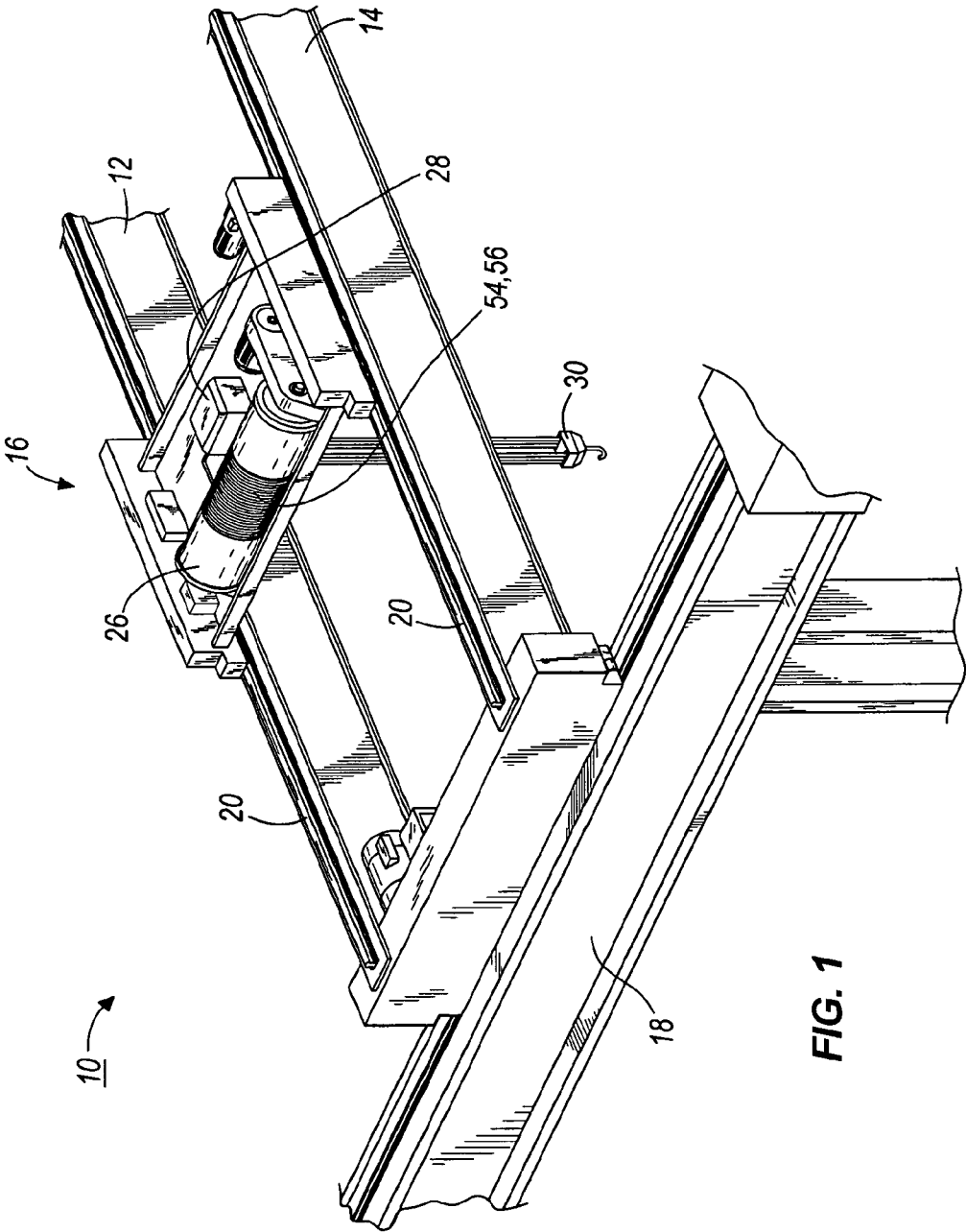

FIG. 1

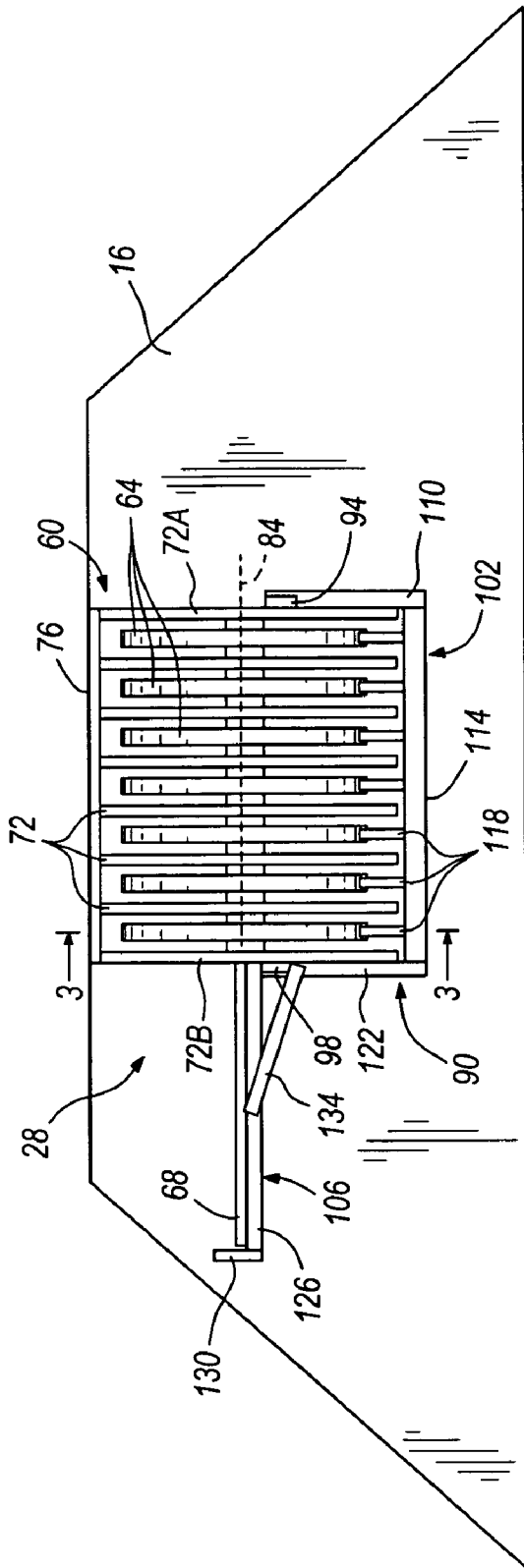

FIG. 2

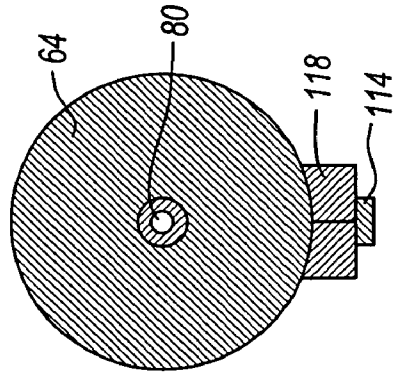

FIG. 3

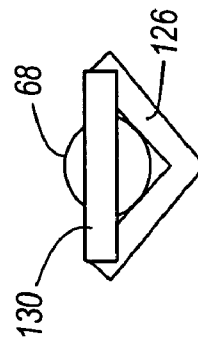

FIG. 4

## PIN CHANGING DEVICE AND METHOD

## BACKGROUND

The present invention relates to overhead cranes and particularly to upper blocks of overhead cranes. More particularly, the present invention relates to the main support pin in an upper block of an overhead crane.

Conventional overhead cranes include a wire rope that is reeved between an upper block and a lower block. The upper block typically includes multiple sheaves supported on a main pin and around which the wire rope is reeved. To change the main pin that supports the multiple sheaves, the wire rope typically must be unreeved from the upper block sheaves and the lower block sheaves. A device that permits a main pin of an upper block to be changed without unreeving and rereeving the upper block would be welcomed by users of overhead cranes.

## SUMMARY

In one embodiment, the invention provides a pin removal assembly for use with an upper block of a crane. The upper block includes a frame, a plurality of sheaves, and a removable sheave pin that defines an axis of rotation for the sheaves and supports the sheaves within the frame. The pin removal assembly comprises a sheave support mountable to the frame of the upper block and a pin support mountable to the frame of the upper block. The pin support is configured to support the sheave pin when the sheave pin is removed from the upper block.

In another embodiment, the invention provides a pin removal assembly for use with an upper block of a crane. The upper block includes a frame, a plurality of sheaves, and a removable sheave pin that defines an axis of rotation for the sheaves and supports the sheaves within the frame. The pin removal assembly comprises a first support bracket attached to a sidewall of the upper block frame and a sheave support mountable to the first support bracket. The sheave support includes a base portion configured to support the sheaves and a support arm portion releasably mountable to the first support bracket.

In yet another embodiment, the invention provides an upper block assembly for an overhead crane. The upper block assembly includes an upper block and a pin removal assembly releasably mounted to the upper block. The upper block includes a frame with a first sidewall and a second sidewall, a plurality of sheaves arranged within the frame, and a sheave pin that supports the sheaves within the frame. Each sidewall and each sheave includes a hole therethrough, with the holes defining an axis of rotation and receiving the sheave pin.

In another embodiment the invention provides a method of supporting an upper block of an overhead crane during replacement of a sheave pin. The upper block includes a frame, a plurality of sheaves and a removable sheave pin that defines an axis of rotation from the sheaves and supports the sheaves within the frame. The method includes mounting first and second support brackets to opposite sidewalls of the upper block frame, mounting a sheave support including a base portion to at least one of the support brackets, and positioning the base portion of the sheave support to support each sheave. The method further includes mounting a pin support to the other support bracket located adjacent the sheave pin and sliding the sheave pin from the upper block wherein the pin support supports the sheave pin.

Other aspects of the invention will become apparent by consideration of the detailed description and accompanying drawings.

## BRIEF DESCRIPTION OF THE DRAWINGS

FIG. 1 is a perspective view of a crane including a trolley having an upper block according to the present invention.

FIG. 2 illustrates a pin removal assembly according to the present invention that is connected to an upper block.

FIG. 3 is a cross-sectional view of the pin removal assembly of FIG. 1 taken along line 3-3 of FIG. 1, and showing a sheave support of the pin removal assembly engaged with a sheave of the upper block.

FIG. 4 is an end view of the pin removal assembly of FIG. 1 showing a main pin of the upper block supported by the pin removal assembly before it is inserted into and through the sheaves of the upper block.

Before any embodiments of the invention are explained in detail, it is to be understood that the invention is not limited in its application to the details of construction and the arrangement of components set forth in the following description or illustrated in the following drawings. The invention is capable of other embodiments and of being practiced or of being carried out in various ways. Also, it is to be understood that the phraseology and terminology used herein is for the purpose of description and should not be regarded as limiting. The use of "including," "comprising," or "having" and variations thereof herein is meant to encompass the items listed thereafter and equivalents thereof as well as additional items. Unless specified or limited otherwise, the terms "mounted," "connected," "supported," and "coupled" and variations thereof are used broadly and encompass both direct and indirect mountings, connections, supports, and couplings. Further, "connected" and "coupled" are not restricted to physical or mechanical connections or couplings.

## DETAILED DESCRIPTION

In FIG. 1, a crane 10 includes a trolley 16 that moves along girder rails 20 that sit atop a first girder 12 and a second girder 14. The first girder 12 and the second girder 14 translate along a main support beam 18 on one end and an additional support beam (not shown) parallel to beam 18 at an opposite end of the girders. The trolley 16 includes a drum 26 around which is wrapped two wire ropes 54, 56. As the drum 26 rotates and winds up the wire ropes 54, 56, a lower block 30 is lifted, as will be readily apparent to those of skill in the art. As illustrated in FIG. 1, the lower block 30 includes a hook that can be used for lifting. However, the lower block 30 could include other configurations for lifting, as will also be readily apparent to those of skill in the art.

The translation of the trolley 16 along the first and second girders 12, 14 and the translation of the first and second girders 12, 14 along the main support beams 18 (only one of which is shown), allows the crane 10 to position the lower block 30 in virtually any location in a space in which the crane 10 is installed. The main support beam 18 is shown as a straight beam. As will be readily known to those of skill in the art, the main support beam 18 may alternatively be curved to match the inside wall contours of a round building. For example, a polar crane similar to crane 10, shown in FIG. 1, may be used in a nuclear containment building that is built in a round configuration, in which case the main support beam 18 will be shaped in a circle instead of a straight line.

As shown in FIG. 1, the wire ropes 54, 56 extend from the drum 26 to the lower block 30, which contains a plurality of

sheaves (not shown) around which the wire ropes **54, 56** pass. From the lower block **30**, the wire ropes **54, 56** extend to an upper block **28** that also contains a plurality of sheaves (not shown). After reeving back and forth between the lower block **30** and upper block **28**, as will be readily understood by those of ordinary skill in the art, the wire ropes **54, 56** end within the upper block **28**.

Referring to FIG. 2, the upper block **28** includes an upper block frame **60**, a plurality of sheaves **64** arranged within the frame **60**, and a sheave pin **68** that supports the sheaves **64** within the frame **60**. The frame **60** illustrated in FIG. 2 includes a plurality of vertical walls **72**, with the two outermost support walls defining first and second sidewalls **72A** and **72B**. A horizontal top wall **76** extends across top surfaces of each wall **72** between the first and second sidewalls **72A, 72B**. Each wall **72** includes a hole (not shown) therethrough for receiving the sheave pin **68**. As will be readily apparent to those of skill in the art, in further embodiments of the upper block frame, other configurations are used, for example, fewer or more vertical walls are included and top or bottom walls are included.

The sheaves **64** are arranged and aligned in parallel within the upper block frame **60**. Each sheave includes a hole **80** (shown in FIG. 3) therethrough for receiving the sheave pin **68**. The sheave pin **68** defines an axis of rotation **84** for the sheaves **64** within the frame **60**. Although seven sheaves **64** are shown in the embodiment illustrated in FIG. 2, it will be readily apparent to those of skill in the art that fewer or more sheaves may be used in the upper block **28**.

The upper block assembly **28** illustrated in FIG. 2 includes a pin removal assembly **90** releasably mounted to the upper block **28** for supporting the sheaves **64** and the upper block **28** when the sheave pin **68** is removed from the upper block **28**. The pin removal assembly **90** allows the sheave pin **68** to be removed and/or replaced from the upper block **28** without unreeving the wire ropes **54, 56** from the upper block sheaves **64** and sheaves (not shown) of the lower block **30**. Further, the pin removal assembly **90** allows the sheave pin **68** to be removed and reinstalled without removing the upper block sheaves **64**. During use, the pin removal assembly **90** supports the sheaves **64** within the upper block frame **60** such that the sheave pin **64** is removable from the upper block **28** without unreeving and re-reeving the wire ropes **54, 56** or removing the upper block sheaves **64**.

In the illustrated embodiment, the pin removal assembly **90** includes a first support bracket **94**, a second support bracket **98**, a sheave support **102** for supporting the sheaves **64** and a pin support **106** for supporting the sheave pin **68** when the sheave pin **68** is removed from the upper block **28**. The first and second support brackets **94, 98** are attached to the first and second sidewalls **72A, 72B**, respectively, of the upper block frame **60**. The support brackets **94, 98** are either permanently attached or removably attached to the sidewalls **72A, 72B**. The sheave support **102** is releasably mounted to the first support bracket **94** and the pin support **106** is releasably mounted to the second support bracket **98**. In another embodiment, the sheave support **102** and the pin support **106** are releasably mounted to the upper block frame **60** directly. In still another embodiment, the upper block frame **60** includes keeper plates to which the sheave support **102** and the pin support **106** attach.

In the illustrated embodiment, the sheave support **102** includes a vertical support arm **110** and a base portion **114**. The support arm **110** of the sheave support **102** is mounted at one end to the first support bracket **94**. The base portion **114**, or a beam, is attached to the other end of the support arm **110** and extends substantially perpendicular to the support arm

**110**. A plurality of wedges **118**, or V-shaped supports, are attached to the base portion **114** of the sheave support **102**. As shown in FIG. 3, each wedge **118** is configured to support one sheave **64** when the pin removal assembly **90** is in use. Each wedge **118** is vertically adjusted with a screw (not shown) to position the wedge **118** to support a sheave **64**. In a further embodiment, each wedge, or support, is configured to support more than one sheave. Further, it will be readily apparent to those skilled in the art that the wedge may be comprised of one or two pieces.

In the illustrated embodiment, the pin support **106** includes a vertical first support portion **122** and a horizontal second support portion **126**. The first support portion **122** of the pin support **106** is mounted at one end to the second support bracket **98** of the upper block frame **60**. The other end of the first support portion **122** is attached to the base portion **114** of the sheave support **102**. In another embodiment, the sheave support **102** and the pin support **106** are not attached.

One end of the second support portion **126** is attached to the first support portion **122** of the pin support **106**. The second support portion **126** extends outward from the upper block frame **60** such that the second support portion **126** is substantially aligned in parallel with the rotation axis **84** defined by the sheave pin **68**. The second support portion **126** is V-shaped and configured to support a sheave pin when the sheave pin **68** is removed from the upper block **28** or a new pin is installed into the upper block **28**. It will be readily apparent to those skilled in the art that the second support portion may have any configuration or shape suitable for supporting a sheave pin removed from the upper block.

In the illustrated embodiment, a cross bar **130** is attached to the second support portion **126** of the pin support **106**. The cross bar **130** supports a pulling/pushing mechanism (not shown) for removing the sheave pin **68** from the upper block **28**. One example of a pulling/pushing mechanism is a hydraulic cylinder. In the illustrated embodiment, the mechanism is positioned to pull the sheave pin **68** in order to remove the sheave pin **68** from the upper block **28**, and to push the sheave pin **68** in order to install the sheave pin **68** into the upper block **28**. In a further embodiment, the mechanism is positioned to push the sheave pin **68** in order to remove the sheave pin **68** from the upper block **28**, and to pull the sheave pin **68** in order to install the sheave pin **68** into the upper block **28**. Further, in the illustrated embodiment of the pin support **106**, a brace member **134** extends between the second support portion **126** and the second support bracket **98**. The brace member **134** prevents the sheave pin **68** from falling from the pin support **106** when the pin **68** is removed from the upper block **28**.

The pin removal assembly **90** is not permanently attached to the upper block **28**, but is only attached during removal and replacement of the sheave pin **68** relative to the upper block **28**. In use, the first and second support brackets **94, 98** are attached to the opposite sidewalls **72A, 72B** of the upper block frame **60**. The sheave support **102** is mounted to the first support bracket **94**. The wedges **118** are positioned and adjusted individually, or as a unit, such that each wedge **118** supports one of the sheaves **64**. Next, the pin support **106** is mounted to the second support bracket **98**. The sheave pin **68** is removed from the upper block **28** by a pulling/pushing mechanism and the pin support **106** supports the sheave pin **68** when it is removed from the upper block **28**.

To replace the sheave pin **68** with a new sheave pin (not shown), the sheave pin **68** is removed from the pin support **106** and a new sheave pin is placed in the pin support **106**. The new sheave pin is positioned within the upper block **28** to support the sheaves **64** within the upper block **28** by sliding the pin through the holes of the upper block frame **60** and

5

holes **80** of the sheaves **64**. During the process of removing and replacing the sheave pin **68**, the sheave support **102** supports the sheaves **64** within the upper block frame **60** such that the sheave pin **68** is removable without unreeving the wire ropes **54, 56** from the sheaves **64** or removing the upper block sheaves **64**.

It will be readily apparent to those skilled in the art that a pin support is not necessary for supporting sheaves and maintaining the upper block assembly **28** together during removal of a sheave pin. In another embodiment, the first and second support brackets **94, 98** are permanently attached to the upper block frame **60**. In still another embodiment, the vertical support arm **110** of the sheave support **102** and the first support portion **122** of the pin support **106** are separately attached to the support brackets **94, 98** relative to the sheave support **102** and the pin support **106**, respectively.

The foregoing description of the present invention has been presented for purposes of illustration and description. Furthermore, the description is not intended to limit the invention to the form disclosed herein. Consequently, variations and modifications commensurate with the above teachings, and the skill or knowledge of the relevant art, are within the scope of the present invention. The embodiments described herein are further intended to explain best modes known for practicing the invention and to enable others skilled in the art to utilize the invention in such, or other, embodiments and with various modifications required by the particular applications or uses of the present invention. It is intended that the appended claims be construed to include alternative embodiments to the extent permitted by the prior art. Various features and advantages of the invention are set forth in the following claims.

What is claimed is:

1. A pin removal assembly for use with an upper block of a crane, the upper block including a frame, a plurality of sheaves, and a removable sheave pin that defines an axis of rotation for the sheaves and supports the sheaves within the frame, the pin removal assembly comprising:

a sheave support mountable to the frame of the upper block; and

a pin support mountable to the frame of the upper block, the pin support configured to support the sheave pin when the sheave pin is removed from the upper block; and wherein the sheave support includes a plurality of wedges configured to support the sheaves, each wedge supporting at least one of the sheaves.

2. The pin removal assembly of claim 1, and further comprising a support bracket mounted to a sidewall of the upper block frame wherein the sheave support is releasably mounted to the support bracket.

3. The pin removal assembly of claim 1, and further comprising a support bracket mounted to a sidewall of the upper block frame wherein the pin support is releasably mounted to the support bracket.

4. The pin removal assembly of claim 1 wherein the sheave support includes a support arm mounted to the upper block frame and a base portion attached to the support arm, the base portion configured to support the sheaves.

5. The pin removal assembly of claim 1 wherein the pin support comprises:

a first support portion mounted to the upper block frame; and

a second support portion extending outward from the upper block frame and attached to the first support portion, the second support section substantially aligned in parallel with the rotation axis for the sheaves and configured to support the sheave pin when removed from the frame.

6

6. The pin removal assembly of claim 1, and further comprising a cross bar attached to the pin support for supporting a mechanism for removing the sheave pin from the upper block.

7. The pin removal assembly of claim 1 wherein at least a portion of the pin support is V-shaped to support the sheave pin.

8. A pin removal assembly for use with an upper block of a crane, the upper block including a frame, a plurality of sheaves, and a removable sheave pin that defines an axis of rotation for the sheaves and supports the sheaves within the frame, the pin removal assembly comprising:

a first support bracket attached to a side wall of the upper block frame;

a sheave support mountable to the first support bracket, the sheave support including a base portion configured to support the sheaves and a support arm portion releasably mounted to the first support bracket.

9. The pin removal assembly of claim 8 wherein the base portion includes a plurality of wedges, each wedge for supporting at least one sheave.

10. The pin removal assembly of claim 8, and further comprising:

a second support bracket attached to an opposite sidewall of the upper block frame; and

a pin support mountable to the second support bracket, the pin support configured to support the sheave pin when removed from the upper block.

11. The pin removal assembly of claim 10 wherein the pin support comprises:

a first support portion mounted to the second support bracket; and

a second support portion extending outward from the respective sidewall of the upper block frame and attached to the first support portion, the second support section substantially aligned in parallel with the rotation axis for the sheaves and configured to support the sheave pin when the sheave pin is removed from the frame.

12. The pin removal assembly of claim 10 wherein at least a portion of the pin support is V-shaped to support the sheave pin.

13. A pin removal assembly for use with an upper block of a crane, the upper block including a frame, a plurality of sheaves, and a removable sheave pin that defines an axis of rotation for the sheaves and supports the sheaves within the frame, the pin removal assembly comprising:

a support bracket mounted to a sidewall of the upper block frame;

a sheave support mountable to the frame of the upper block; and

a pin support mountable to the support bracket, the pin support configured to support the sheave pin when the sheave pin is removed from the upper block.

14. The pin removal assembly of claim 13, and further comprising another support bracket mounted to a sidewall of the upper block frame wherein the sheave support is releasably mounted to the another support bracket.

15. The pin removal assembly of claim 13 wherein the sheave support includes a plurality of wedges configured to support the sheaves, each wedge supporting at least one of the sheaves.

7

16. The pin removal assembly of claim 13 wherein the sheave support includes a support arm mounted to the upper block frame and a base portion attached to the support arm, the base portion configured to support the sheaves.

17. The pin removal assembly of claim 13 wherein the pin support comprises:

a first support portion mounted to the support bracket; and  
a second support portion extending outward from the upper block frame and attached to the first support portion, the second support section substantially aligned in parallel

8

with the rotation axis for the sheaves and configured to support the sheave pin when removed from the frame.

18. The pin removal assembly of claim 13, and further comprising a cross bar attached to the pin support for supporting a mechanism for removing the sheave pin from the upper block.

19. The pin removal assembly of claim 13 wherein at least a portion of the pin support is V-shaped to support the sheave pin.

\* \* \* \* \*