



(11) **EP 3 067 745 A1**

(12) **EUROPEAN PATENT APPLICATION**  
published in accordance with Art. 153(4) EPC

(43) Date of publication:  
**14.09.2016 Bulletin 2016/37**

(21) Application number: **14860630.4**

(22) Date of filing: **24.10.2014**

(51) Int Cl.:  
**G03B 11/04** (2006.01) **G03B 17/02** (2006.01)  
**H04N 5/225** (2006.01) **H04N 7/15** (2006.01)

(86) International application number:  
**PCT/JP2014/078321**

(87) International publication number:  
**WO 2015/068591 (14.05.2015 Gazette 2015/19)**

(84) Designated Contracting States:  
**AL AT BE BG CH CY CZ DE DK EE ES FI FR GB GR HR HU IE IS IT LI LT LU LV MC MK MT NL NO PL PT RO RS SE SI SK SM TR**  
Designated Extension States:  
**BA ME**

(30) Priority: **06.11.2013 JP 2013230385**

(71) Applicant: **Ricoh Company, Ltd.**  
**Tokyo 143-8555 (JP)**

(72) Inventor: **HIRAMATSU, Takahiro**  
**Tokyo 143-8555 (JP)**

(74) Representative: **Schwabe - Sandmair - Marx**  
**Patentanwälte Rechtsanwalt**  
**Partnerschaft mbB**  
**Joseph-Wild-Straße 20**  
**81829 München (DE)**

(54) **IMAGE-CAPTURING DEVICE**

(57) An imaging device includes an imaging unit having an imaging part, and a holder to hold the imaging part at one end; a housing including a recess part in a first surface to house the imaging unit; and a hinge device having a hinge member housed in the recess part pivotally coupled to the housing around an axle extending in parallel with the first surface. The imaging unit pivots around the axle via the hinge device between a housing position and a projecting position of the imaging unit. The imaging part includes a rectangular imaging element, a lens introducing external light into the imaging element, and a lens hood at an outer periphery of the lens. The lens hood projects from the lens surface by a distance allowing the imaging part to introduce necessary light from the lens into the imaging element and block unnecessary light.

**FIG.2**

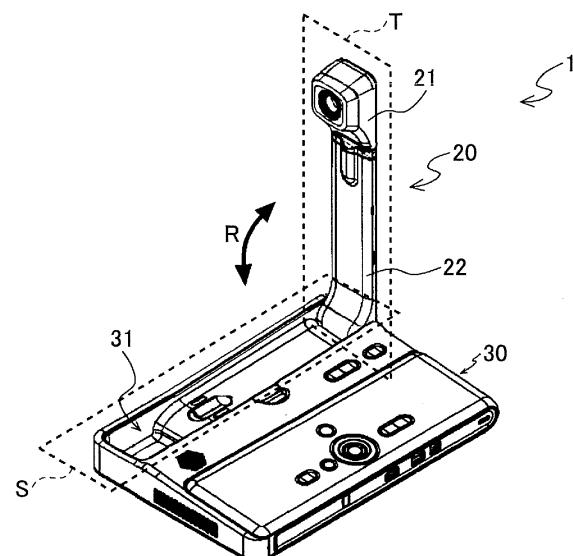

**EP 3 067 745 A1**

**Description**

[Technical Field]

**[0001]** An aspect in the following disclosure relates to an imaging device provided with a lens protecting mechanism.

[Background Art]

**[0002]** Conference systems capable of being used to conduct a remote conference between remote places via communications networks such as the Internet have become popular. Such conference systems utilize a technology known in the art to conduct a remote conference; that is, a communications apparatus acquires images and speech of conference participants in one conference room, converts the acquired images and speech into digital data, and transmits the converted digital data to a counterpart communications apparatus. The counterpart communications apparatus subsequently displays the acquired images and outputs the speech in a counterpart conference room so that conference participants in two remotely separate conference rooms can conduct a remote conference in a state close to an actual conference.

**[0003]** Patent Document 1, for example, discloses a communications apparatus having excellent portability as an example of the above technology. The disclosed communications apparatus has a uniaxial hinge configured to pivotally connect an image input unit including a digital camera and a housing.

[Related-Art Document]

[Patent Document]

**[0004]** [Patent Document 1] Japanese Unexamined Patent Application Publication No.2012-151521

[Summary of the Invention]

[Problem to be Solved by Invention]

**[0005]** The technology disclosed in Patent Document 1 may improve portability and operability of the communications apparatus because the disclosed technology enables the communications apparatus to house a camera arm to protect a camera lens, thereby no longer requiring a lens cap attached to the communications apparatus so as to eliminate inefficient operations of attaching and detaching the lens whenever the communications apparatus is used and unused. The technology disclosed in Patent Document 1 may further provide the communications apparatus with a protruding object and a lens filter to prevent the lens from contacting the housing when housing the camera arm.

**[0006]** It is one of objects of the present invention to solve such problems. In other words, it is an object of the

present invention to provide a communications apparatus capable of protecting the lens without a complicated mechanism and avoid inefficient operations as well as preventing the quality of the acquired images from degrading due to undesired light.

[Means to Solve the Problem]

**[0007]** According to an aspect in the disclosure, there is provided an imaging device that includes an imaging unit having an imaging part configured to image a subject, and a holder configured to hold the imaging part at one end thereof; a housing including a recess part formed in a first surface thereof, and configured to house the imaging unit; and a hinge device having a hinge member housed in the recess part pivotally coupled to the housing around an axle extending approximately in parallel with the first surface inside the recess part of the housing. The imaging unit pivots around the axle via the hinge device between a housing position at which the imaging unit is housed inside the recess part of the housing and a projecting position at which the imaging unit is projected from the recess part of the housing. The imaging part includes an imaging element having an approximately rectangular shape, a lens configured to introduce external light into the imaging element, and a lens hood mounted at an outer periphery of the lens. The lens hood projects from a surface of the lens by a distance to allow the imaging part to introduce light necessary for imaging a subject from the lens into the imaging element and to block unnecessary light introduced from the lens into the imaging element.

[Advantageous Effect of the Invention]

**[0008]** According to an aspect in the disclosure, it is possible to protect a lens without a complicated mechanism and avoid inefficient operations as well as preventing the quality of the acquired images from degrading due to undesired light.

[Brief Description of Drawings]

**[0009]**

FIG. 1 is a schematic perspective view illustrating an imaging apparatus according to an embodiment; FIG. 2 is a schematic perspective view illustrating an imaging apparatus according to the embodiment; FIG. 3 is a schematic perspective view illustrating an imaging part according to the embodiment; FIG. 4 is a front view illustrating a lens hood according to the embodiment; FIG. 5 is a cross-sectional view illustrating the lens hood according to the embodiment; FIG. 6 is a perspective view illustrating the lens hood according to the embodiment; FIG. 7 is a perspective view illustrating the lens hood

according to the embodiment;  
 FIG. 8 is a top view illustrating the lens hood according to the embodiment;  
 FIG. 9 is a perspective view illustrating a housing of the imaging part according to the embodiment;  
 FIG. 10 is a schematic diagram illustrating a design of the lens hood according to the embodiment; and  
 FIG. 11 is a schematic diagram illustrating the design of the lens hood according to the embodiment.

[Mode for Carrying Out the Invention]

**[0010]** In the following, an imaging device according to an embodiment of the present invention will be described with reference to the accompanying drawings; however, the present invention is not limited to the specifically disclosed embodiment within the gist of the present invention. Note that the same or similar components are provided with the same reference numbers in the drawings to omit or partially omit duplicated illustration.

**[0011]** The following embodiment illustrates a TV conference apparatus illustrated in FIGS. 1 and 2 as an example of an apparatus provided with an imaging device according to an embodiment. However, the invention is not limited to the TV conference. The invention may include a communications apparatus such as a camcorder, a digital still camera, and a TV conference apparatus, or an information processing apparatus such as a smartphone. The invention applied may further include an imaging device, a communications apparatus, and an information processing apparatus of another type that incorporates an imaging part in a housing of a main body.

**[0012]** The following illustrates a schematic configuration of a TV conference apparatus 1 as an apparatus having an imaging device according to an embodiment with reference to FIGS. 1 and 2. FIG. 1 is an external view illustrating the TV conference apparatus 1 that is unused. The TV conference apparatus 1 that is unused has a substantially thin and oblong rectangular parallelepiped outer shape or a substantially plate-like outer shape. The TV conference apparatus 1 may be placed on a table or a desk parallel to a horizontal plane.

**[0013]** The TV conference apparatus 1 includes a camera part 20 serving as an imaging unit composed of a camera head 21 and a camera arm 22, and a housing 30. The camera head 21 serves as an imaging part configured to image a subject, and the camera arm 22 serves as a holder configured to hold the camera head 21 at one end. The housing 30 has a recess part 31 as an upper surface of one side, which is configured to house the camera part 20. The camera part 20 that is not being used is housed in the recess part 31, as illustrated in FIG. 1. This facilitates users' carrying the TV conference apparatus 1, thereby improving its portability. The camera part 20 corresponds to an imaging device.

**[0014]** Next, an illustration is given of the TV conference apparatus 1 that is used with additional reference

to FIG. 2. In this example, the TV conference apparatus 1 is provided with a hinge device H. The hinge device H includes a hinge member connected to the housing 30 inside the recess part 31 relatively and pivotally around an axle extending in substantially parallel with the upper surface inside the recess part 31 of the TV conference apparatus 1. When the camera part 20 is used, the camera part 20 pivotally moves via a pivoting shaft of the hinge device H in a pivoting direction R to a position perpendicular to the housing 30.

**[0015]** The following specifically describes a pivoting mechanism of the camera part 20. The camera part 20 is configured to pivotally moves between a housing position S and projecting position T. The housing position S is a position around the axle at which the camera part 20 is housed via the hinge device H inside the recess part 31, and the projecting position T is a position at which the camera part 20 projects from the recess part 31.

**[0016]** The TV conference apparatus 1 according to the embodiment when it is used is configured to pivotally move the camera part 20 from the housing position S to the projecting position T, thereby matching the user's eye and a height of the camera head 21. A position of the images projected from the camera part 20 onto a predetermined projecting part thus matches the user's eye to facilitate the user's observation of the projected images.

**[0017]** The camera part 20 that is in use is vertically projected from the housing 30, which is not easy for the user to carry. However, the TV conference apparatus 1 according to the embodiment is configured to house the camera part 20 inside the recess part 31 to enable the user to easily carry the TV conference apparatus 1, thereby improving the portability of the TV conference apparatus 1.

**[0018]** The structural features of the TV conference apparatus 1 further include a lens hood configured to protect a lens part of the camera part 20 from external impacts and dirt when the camera part 20 is housed in the housing 30, and prevent the damage to the lens part caused by contact between the housed lens part and the surface of the housing 30.

**[0019]** Note that a typical digital single-lens reflex camera or a camcorder has a lens hood simply attached to the camera lens, and the lens hood of this configuration does not serve as a protector to prevent the camera lens from being damaged when the camera is housed. The digital single-lens reflex camera or the camcorder uses a lens cover to simply protect a lens surface from scratching or dirt. That is, the digital single-lens reflex camera or the camcorder needs to have a separate lens cover.

**[0020]** The lens contacts the housing 30 without the lens hood when the camera part 20 is housed in the recess part 31. For example, when a user replaces the camera arm 22 strongly, the lens may strongly contact the housing 30. This may damage the lens due to impact.

**[0021]** On the other hand, the lens may be protected by attaching a protruding object around the lens. However, the protruding object may have a shape that inter-

feres with rays of light incident on the lens, generating so-called vignetting that is physically introducing a shadow in an image taken. Thus, simply providing a protruding object for protecting the lens may fail to improve the quality of the image.

**[0022]** In the present embodiment, there may be employed a later-described lens hood having a specific feature in addition to the above-described pivoting mechanism of the camera arm 22. Thus, in the embodiment, there may be the features capable of protecting the lens without a complicated mechanism and avoiding inefficient operations as well as preventing the quality of the acquired images from degrading due to undesired light. Note that in the TV conference apparatus 1 according to the embodiment, lifting the camera arm when using the TV conference apparatus 1 achieves an operation of detaching a lens cap in the typical camera or the like. That is, the TV conference apparatus 1 according to the embodiment provides an effect of omitting the operation of detaching the lens cap.

**[0023]** The following describes a schematic configuration of the camera head 21 provided with the AD server apparatus 11 of the present embodiment with reference to FIGS. 3 to 9. The camera head 21 of the embodiment includes an imaging element 17 (see FIG. 10) having a substantially rectangular shape with an aspect ratio of 16:9, a lens 12 introducing external light into the imaging element 17, and a lens hood 11 having a substantially rectangular shape disposed on an outer periphery of the lens 12. The lens hood 11 having the substantially rectangular shape may have the same height in a horizontal direction since the shape of the lens hood 11 is roughly similar to the shape of the imaging element 17. That is, the lens hood has approximately the same height in vertical and horizontal directions, having taken account of the light incident on the imaging element 17. This facilitates forming the lens hood 11, and further shaping the recess part 31 into a planer shape for placing the camera part 20 into the recess part 31 at the housing position S. Note that the recess part 31 may be shaped to match the shape of the lens hood 11; however, it is not preferable to shape the recess part 31 into a complex form.

**[0024]** FIG. 3 is a perspective view illustrating an example of an appearance of the camera head 21. The lens hood 11 covers an outer circumferential edge of the lens part at an end of a camera head housing 13.

**[0025]** The lens hood 11 includes a gradient part 14 inclined downward from an outer peripheral end on a subject side (outside) of the lens hood 11 to an opening peripheral end on the imaging element side of the lens hood 11. The lens hood 11 includes a stepwise gradient part 14, for example (see FIGS. 3 to 6). This may reduce the proportion of reflection light incident on the lens 12 inside the lens hood 11.

**[0026]** Note that the lens hood 11 may preferably be painted black to further reduce the reflection light.

**[0027]** As illustrated in FIG. 4, the lens hood 11 further includes three protruding objects 110 mutually arranged

at equal intervals on an outer periphery of an opening part K of the lens hood 11, which is fitted with the lens 12 to expose a surface of the lens 12 from the opening part K.

**[0028]** Note that when the lens hood 11 is not provided with the protruding objects 110, the lens 12 may be deflected toward the center of the lens hood 11, which may shield the light incident on the imaging element 17. Further, this configuration of the lens hood 11 and the lens 12 without having the protruding objects 110 in between may allow a gap between the lens hood 11 and the lens 12 to visually stand out conspicuously. Thus, arranging at least three protruding objects 110 mutually at equal intervals on the outer periphery of the opening part K of the lens hood 11 may position the lens 12 at the center of the lens hood 11 to sufficiently introduce the incident light into the imaging element 17 as well as making the gap between the lens hood 11 and the lens 12 to visually less stand out.

**[0029]** As illustrated in FIGS. 6, 7, and 8, four claw parts 15 serving as attaching units are mounted on a rear surface of the lens hood 11; two of the claw parts 15 being mounted at an upper part of the rear face and two of the image forming apparatus 13 being mounted at a lower part of the rear surface to face the claw parts 15 at the upper part. The claw parts 15 each include claws directed outward, and are configured to attach the lens hood 11 to the image forming apparatus 13. The lens hood 11 is attached to the image forming apparatus 13 by fitting the claw parts 15 into counterpart claw receivers 16 formed in the image forming apparatus 13 illustrated in FIG. 9.

**[0030]** Alternatively, an elastic member such as rubber or sponge may be included inside the lens hood 11 instead to serve as the above-described locators and filler for filling the gap between the lens hood 11 and the lens 12.

**[0031]** Further, the lens hood 11 may be formed of a resilient material such as a cushion material (buffer material). Further, a part of the recess part 31 of the housing 30 that faces the camera head 21 housed in the recess part 31 at the housing position S may be formed of a resilient material such as a cushion material. The application of the above-described configuration may improve an impact absorption effect of the camera head 21 or the lens 12.

**[0032]** Further, a middle part 113 of the lens hood 11 has an end face 111 projected toward a subject side of the lens hood 11 with respect to two opposing ends sandwiching the middle part 113 as illustrated in FIG. 8. For example, the middle part 113 of the end face 111 in a longitudinal direction of the lens hood 11 forms a gradual projection with respect to left and right ends of the end face 111 of the lens hood 11. Note that the end face 111 indicates a part of an end face on one side in an approximately rectangular shape of the end face 111.

**[0033]** More specifically, the middle part 113 may be projected from the opposing ends 112 such that a differ-

ence in height between a tangent Y to the middle part 113 and a line segment Z connecting between the opposing ends 112 is approximately 1.0 mm. This structural configuration may restrict a position of the lens hood 11 coming in contact with the recess part 31 to the middle part 113 when the camera part 20 is housed in the recess part 31 of the housing 30. Note that the reason for determining the difference in height to be approximately 1.0 mm is, as illustrated earlier, to form the recess part 31 having a shallow depth. This is because forming the recess part 31 having a greater depth leads to an undesired increase in the thickness of the housing 30. Note that a projecting part with respect to the opposing ends is not limited to the middle part 113, and any part of the end part may be projected with respect to other parts of the end part. Alternatively, the middle parts 113 of both an upper end face and a lower end face in the longitudinal direction of the lens hood 11 may be projected with respect to the opposing ends 112.

**[0034]** If the end face of the lens hood 11 is flat, the overall part of the lens hood 11 may acquire fine scratches due to the contact between the lens hood 11 and the housing 30 when the lens hood 11 is housed in the housing 30, thereby degrading the appearance of the lens hood 11. By contrast, the structural configuration of the lens hood 11 restricts a position to acquire such fine scratches due to the contact between the lens hood 11 and the housing 30 to a specific position of the lens hood 11, thereby allowing the scratch to be unnoticeable to improve a design property.

**[0035]** Note that it is not necessary to form a part of the above-described recess part 31 facing the camera head 21 with a resilient material.

**[0036]** The following illustrates a featured structure of the lens hood 11 according to the embodiment with reference to FIGS. 10 and 11. The TV conference apparatus 1 according to the embodiment preferably employ a wide angle camera to capture all the conference participants in an imaging visual field. The apparatus employing a wide angle camera generally needs to introduce rays of light into the imaging element 17 in a wider range of angles, which leads to a total length of the lens hood to be short; that is, a distance from the lens to the lens hood 11 is short.

**[0037]** Note that the lens hood is configured to block strong rays of light introduced from outside the imaging view angle, and hence prevent an adverse phenomenon such as lens flare. The lens hood may provide higher effect on preventing the adverse phenomenon as the lens hood blocks unnecessary light in a wider range. On the other hand, the lens hood may also need to introduce an amount of light necessary for imaging the subject into the imaging element 17 through the lens.

**[0038]** To reduce contradiction between the two opposing factors, the lens hood 11 may have a projection with a distance from the surface of the lens 12 to acquire light necessary for imaging the subject by the camera head 21 to be introduced from the lens 12 into the imaging

element 17 and to block unnecessary light to be introduced from the lens 12 into the imaging element 17.

**[0039]** Specifically, the lens hood 11 of the embodiment is designed as follows. Dimensions of the lens hood 11 are calculated based on an angle incident on the lens and an effective area of the imaging element 17. The imaging element 17 of the camera head 21 has a landscape-oriented rectangular shape having an aspect ratio of 16:9. Since the imaging element 17 of the embodiment has a landscape-oriented rectangular shape, the imaging element 17 has a rectangular shape having a short length in a vertical direction and a greater width in a horizontal direction. Further, the imaging element 17 of the camera head 21 has a maximum angle of view in a diagonal direction.

**[0040]** The TV conference apparatus 1 is configured to protect the lens 12 by the lens hood 11, where the lens hood 11 is desired to project from a top of the lens by approximately 1.0 mm. In order to allow a tolerance of  $\pm 0.5$  mm and an individual difference in a distance of approximately 0.5 mm from the lens 12 to the imaging element 17 for adjusting a focal distance at assembling, the TV conference apparatus 1 according to the embodiment may preferably have a structural configuration in which a top of the lens hood 11 is at a position 2.0 mm higher than the top of the lens 12. Specifically, a projecting distance R from a top of the surface of the lens 12 of the lens hood 11 is preferably  $1.0 \text{ mm} \leq R \leq 2.0 \text{ mm}$ .

**[0041]** Note that the top of the lens hood 11 may be at a higher position. However, this increases a thickness of the camera head housing 13 due to the configuration of the camera head 21 allowing to house the camera part 20 when the TV conference apparatus 1 is unused. The thickness of the camera head housing 13 to be set may preferably be less than 40 mm.

**[0042]** As illustrated in FIGS. 10 and 11, the TV conference apparatus 1 of the embodiment has the thickness of the camera head housing 13 excluding the lens hood 11 being 30 mm. To further consider the thickness of a receiver side of the housing 30 to receive the camera part 20, the upper limit of the height of the lens hood 11 may preferably be approximately 5.0 mm.

**[0043]** In order to increase the thickness of the lens hood 11 without preventing the light being introduced into the imaging element 17, a diameter of the lens hood 11 needs to be increased. In view of the portability, the TV conference apparatus 1 of the embodiment may desirably be compact. Thus, a preferable height of the lens hood 11 may be, for example, approximately 2.0 mm.

**[0044]** Next, a description is given, with reference to FIG. 10, of an incident path of light incident on the lens 12. The maximum incident angle is obtained in the diagonal direction, and is preferably  $147^\circ$ , the incident angle in the horizontal direction is preferably  $127^\circ$ , and the incident angle in the vertical direction is preferably  $72^\circ$ . Light is incident on the imaging element 17 within a diameter range of 30.32 mm at a position 2.0 mm higher than the top of the above-described lens 12. The lens

hood 11 preferably has dimensions to introduce incident light into the imaging element 17 without vignetting. The camera head 21 may preferably have a diagonal length of the lens hood 11 to be 32 mm.

**[0045]** Note that a lens holder 18 and a sensor substrate 19 are further mounted within the camera head housing 13.

**[0046]** Note that the lens hood 11 may have a round shape having a diameter of 32 mm. Note that in this example of having a round diameter, the angle of view in the horizontal direction and the angle of view in the vertical direction are smaller than the angle of view in the diagonal direction, and effective incident light is incident within a corresponding diameter range of 19.4 mm and 7.90 mm. Thus, the lens hood 11 having a diameter of 32 mm may lower a proportion of unnecessary light to be blocked by the lens hood 11.

**[0047]** The TV conference apparatus 1 of the embodiment may preferably employ a square lens hood. The square lens hood may have smaller dimensions in the horizontal and the vertical directions compared to the round lens hood. The TV conference apparatus 1 of the embodiment having the square lens hood may improve light shielding performance. Further, the TV conference apparatus 1 of the embodiment having the square lens hood may have a compact camera head because the dimensions of the lens hood in the vertical direction are reduced.

**[0048]** Next, an illustration is given of designing the dimensions of the lens hood 11 of the embodiment with reference to FIG. 11. As described above, the imaging element 17 of the camera head 21 has a landscape-oriented rectangular shape having an aspect ratio of 16:9. The lens hood 11 thus has a rectangular shape having a diagonal length of 32 mm and an aspect ratio of 16:9. This indicates that the lens hood 11 may preferably have a lateral length of 27.9 mm, and a vertical length of 15.7 mm, for example.

**[0049]** Further, the present invention is not limited to these embodiments and examples described above, but various variations and modifications may be made without departing from the scope of the present invention.

**[0050]** The present application is based on and claims the benefit of priority of Japanese Priority Application No. 2013-230385, filed on November 6, 2013, the entire contents of which are hereby incorporated by reference.

[Description of Reference Symbols]

**[0051]**

1	TV conference apparatus
11	lens hood
12	lens
13	camera head housing
14	gradient part
15	claw part
16	claw receiver

17	imaging element
20	camera part
21	camera head
22	camera arm
5 30	housing
31	recess part
110	protruding object
112	opposing ends
113	middle part

10

## Claims

1. An imaging device comprising:

15

an imaging unit having an imaging part configured to image a subject, and a holder configured to hold the imaging part at one end thereof; a housing including a recess part formed in a first surface thereof, and configured to house the imaging unit; and

20

a hinge device having a hinge member housed in the recess part pivotally coupled to the housing around an axle extending approximately in parallel with the first surface inside the recess part of the housing, wherein

25

the imaging unit pivots around the axle via the hinge device between a housing position at which the imaging unit is housed inside the recess part of the housing and a projecting position at which the imaging unit is projected from the recess part of the housing, wherein

30

the imaging part includes an imaging element having an approximately rectangular shape, a lens configured to introduce external light into the imaging element, and a lens hood mounted at an outer periphery of the lens, and wherein the lens hood projects from a surface of the lens by a distance to allow the imaging part to introduce light necessary for imaging a subject from the lens into the imaging element and to block unnecessary light introduced from the lens into the imaging element.

35

40

2. The imaging device according to claim 1, wherein when R represents the distance by which the lens hood projects from the surface of the lens, R is  $1.0 \text{ mm} \leq R \leq 2.0 \text{ mm}$ .

45

3. The imaging device according to claim 1 or 2, wherein the lens hood includes an opening part to expose the surface of the lens when the lens is fit into the lens hood, and at least three protruding objects are mounted mutually at equal internals on an outer periphery of the opening part.

55

4. The imaging device according to any one of claims 1 to 3, wherein the lens hood further includes a gradient part, and the gradient part is inclined from a periphery of a subject side end face of the lens hood to a periphery of the opening part of the lens hood toward an imaging element side. 5
5. The imaging device according to any one of claims 1 to 4, wherein the subject side end face of the lens hood includes a middle part and end parts that sandwich the middle part, and at least the middle part projects toward a subject side with respect to the end parts that sandwich the middle part. 10 15
6. The imaging device according to any one of claims 1 to 5, wherein the lens hood is formed of a resilient material. 20
7. The imaging device according to any one of claims 1 to 6, wherein the recess part includes a part facing the imaging part at a housing position at which the imaging unit is housed, and at least the part facing the imaging part is formed of a resilient material. 25

30

35

40

45

50

55

FIG.1

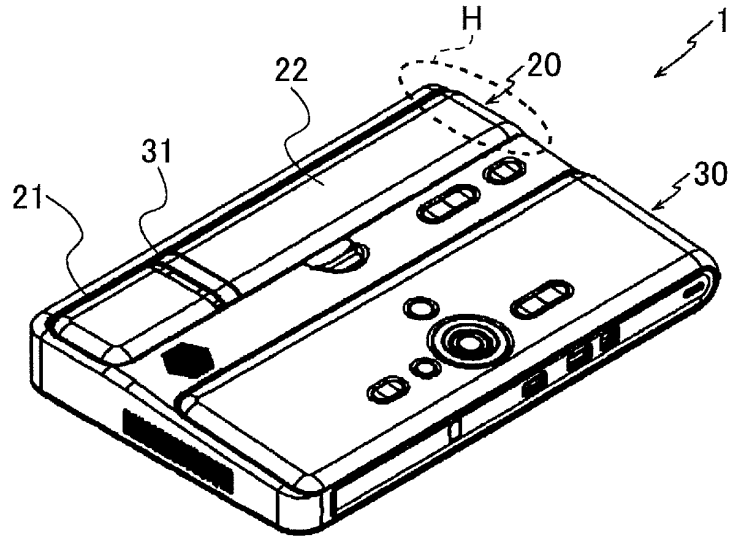

FIG.2

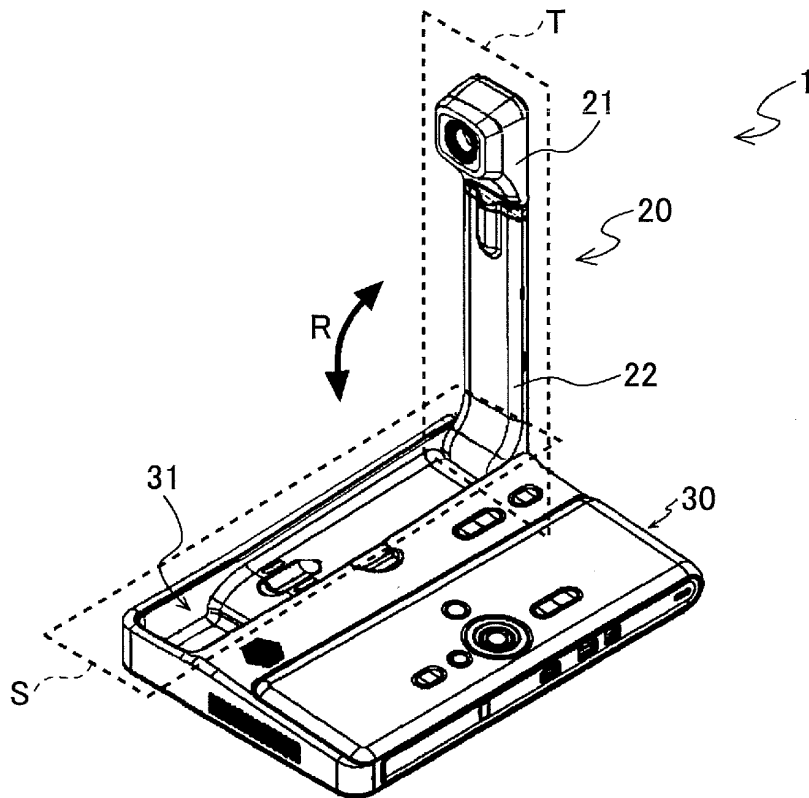

FIG.3

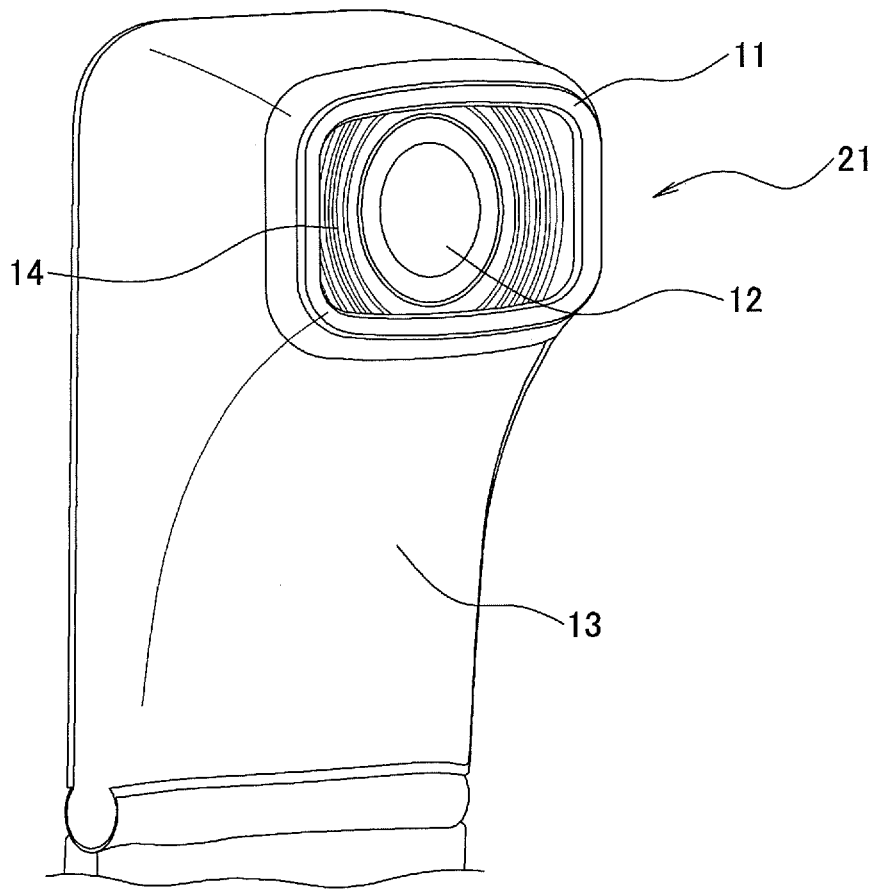

FIG.4

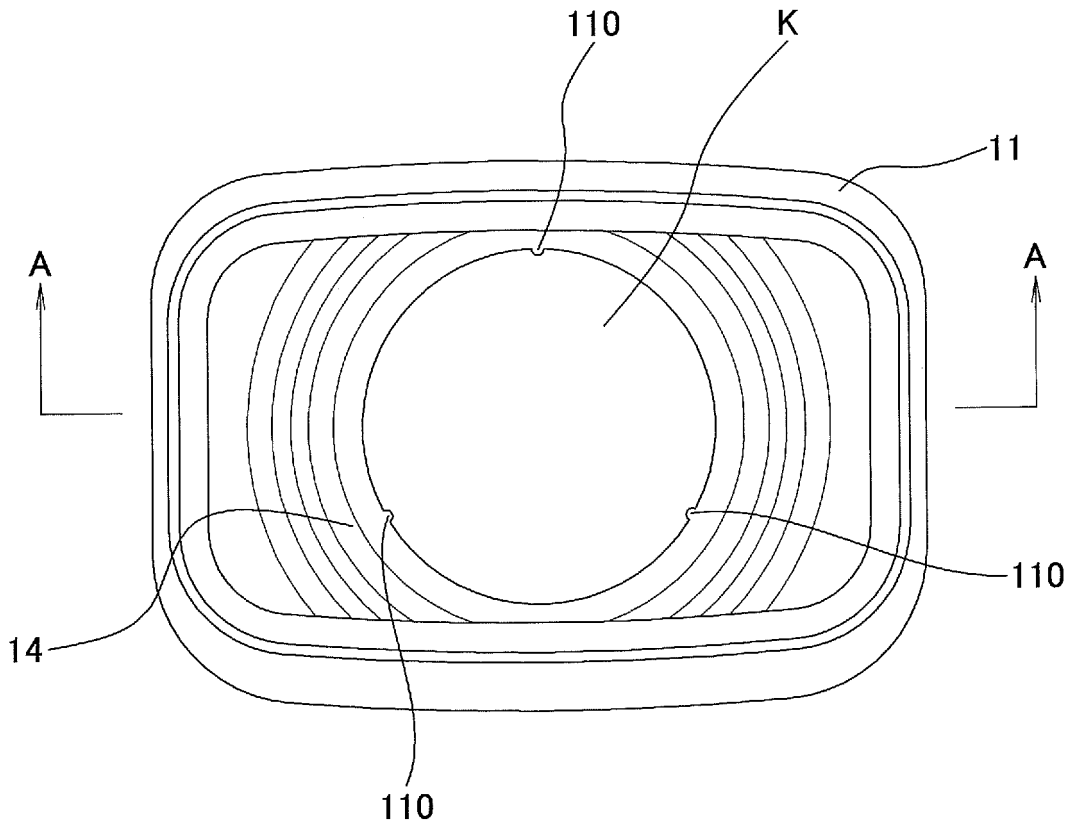

FIG.5

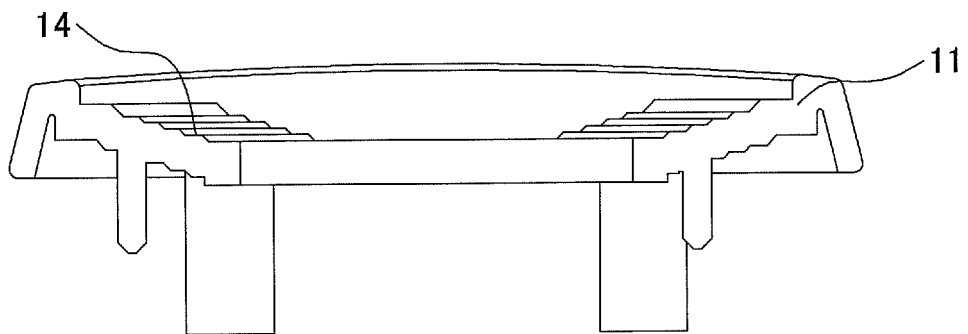

FIG.6

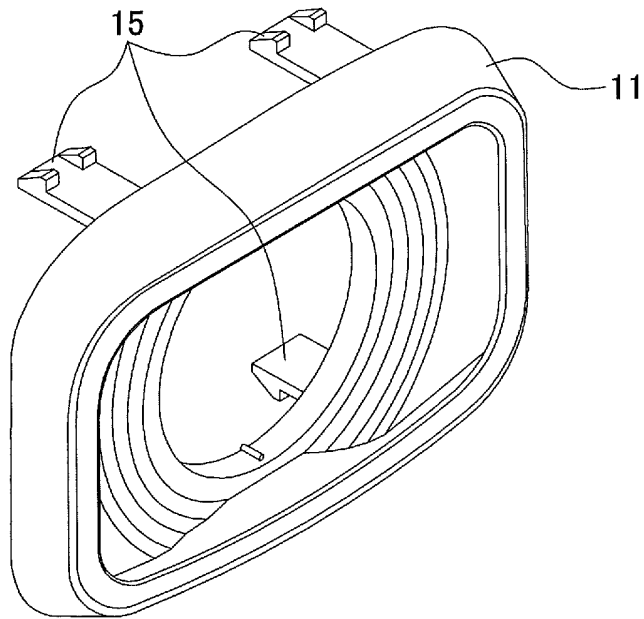

FIG.7

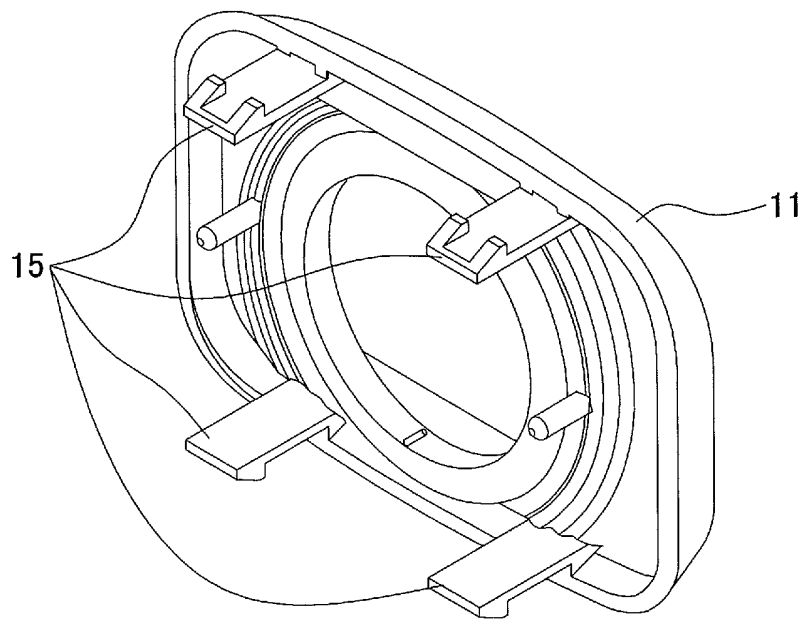

FIG.8

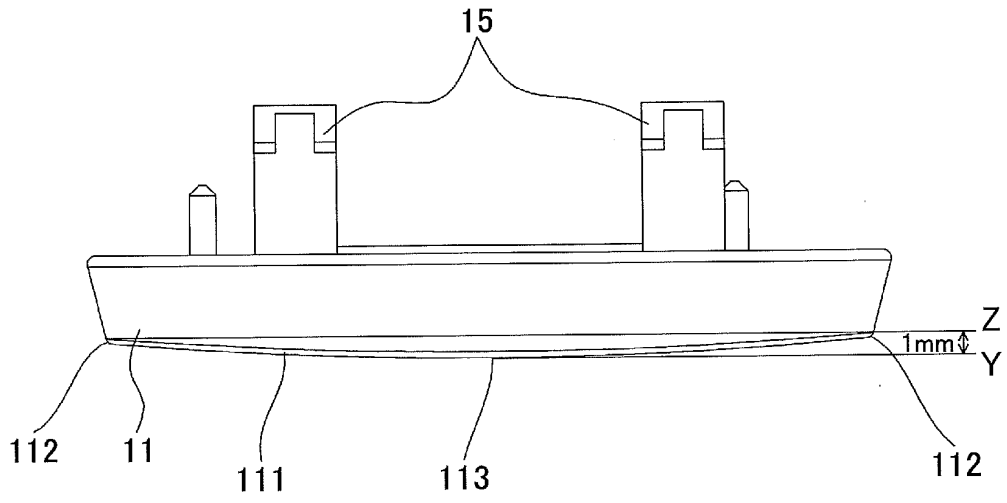

FIG.9

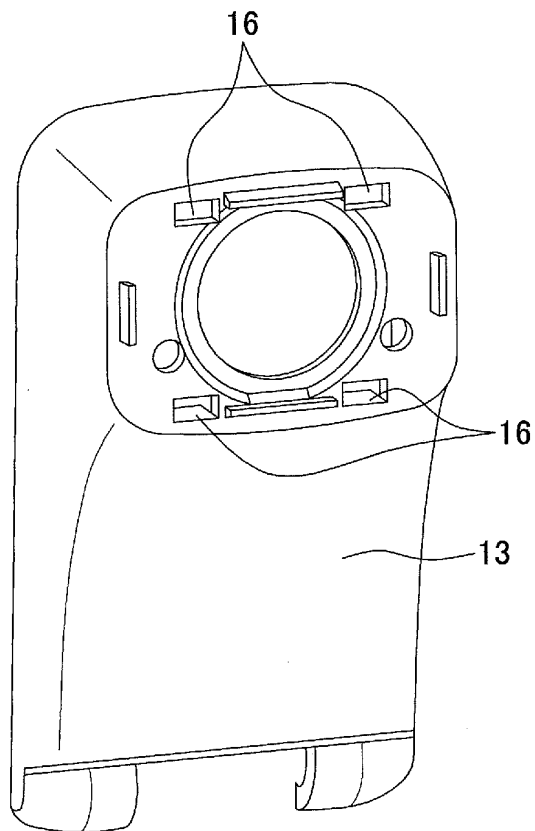

FIG.10

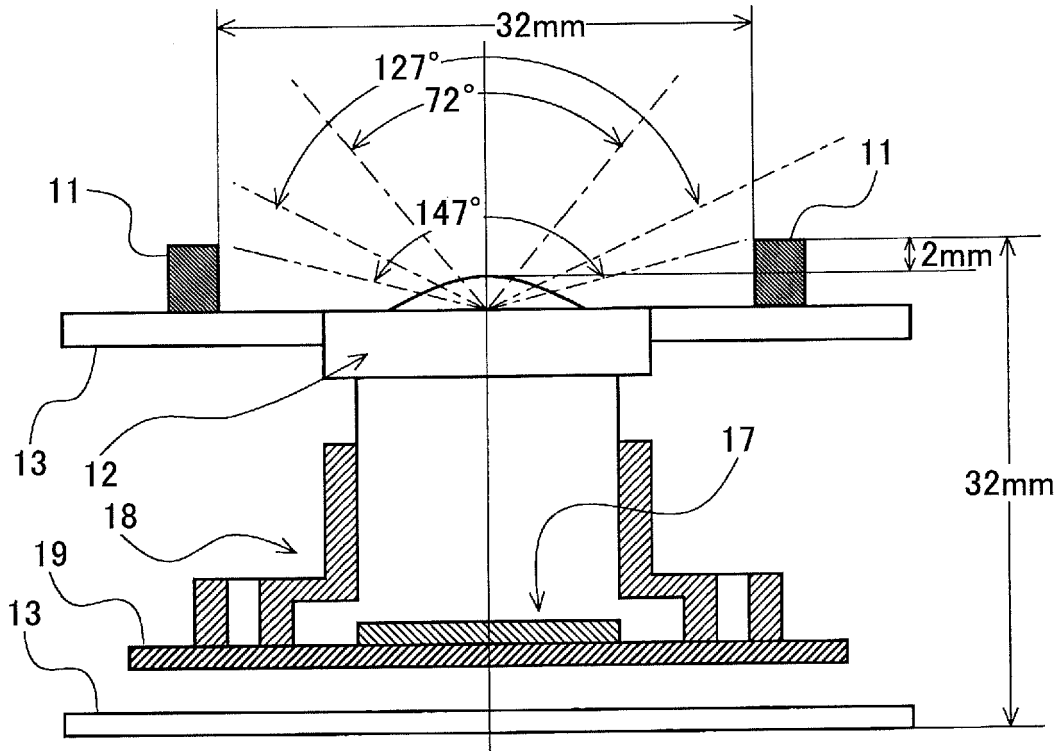
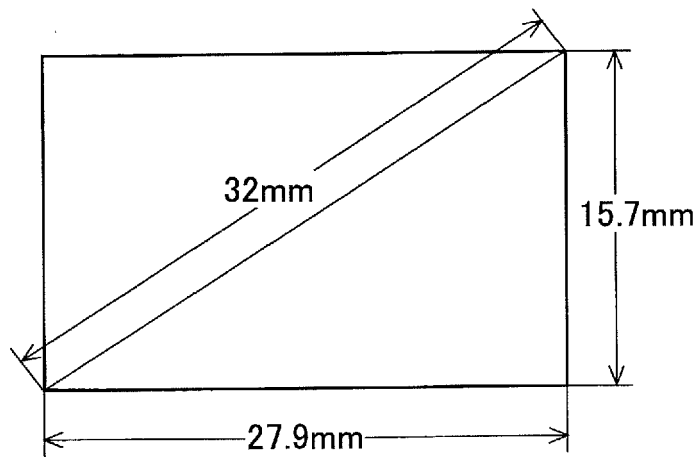

FIG.11



INTERNATIONAL SEARCH REPORT

International application No.  
PCT/JP2014/078321

A. CLASSIFICATION OF SUBJECT MATTER  
G03B11/04(2006.01)i, G03B17/02(2006.01)i, H04N5/225(2006.01)i, H04N7/15(2006.01)i

According to International Patent Classification (IPC) or to both national classification and IPC

B. FIELDS SEARCHED

Minimum documentation searched (classification system followed by classification symbols)  
G03B11/04, G03B17/02, H04N5/225, H04N7/15

Documentation searched other than minimum documentation to the extent that such documents are included in the fields searched  
Jitsuyo Shinan Koho 1922-1996 Jitsuyo Shinan Toroku Koho 1996-2015  
Kokai Jitsuyo Shinan Koho 1971-2015 Toroku Jitsuyo Shinan Koho 1994-2015

Electronic data base consulted during the international search (name of data base and, where practicable, search terms used)

C. DOCUMENTS CONSIDERED TO BE RELEVANT

Category*	Citation of document, with indication, where appropriate, of the relevant passages	Relevant to claim No.
Y A	US 6411332 B1 (EASTMAN KODAK CO.), 25 June 2002 (25.06.2002), column 2, line 44 to column 3, line 25; fig. 1 to 2, 4 (Family: none)	1-2, 4, 6 3, 5, 7
Y A	JP 10-010607 A (Asahi Optical Co., Ltd.), 16 January 1998 (16.01.1998), paragraph [0046]; fig. 7 (Family: none)	1-2, 4, 6 3, 5, 7
A	JP 2012-054814 A (Ricoh Co., Ltd.), 15 March 2012 (15.03.2012), entire text; all drawings (Family: none)	1-7

Further documents are listed in the continuation of Box C.  See patent family annex.

* Special categories of cited documents:	"T" later document published after the international filing date or priority date and not in conflict with the application but cited to understand the principle or theory underlying the invention
"A" document defining the general state of the art which is not considered to be of particular relevance	"X" document of particular relevance; the claimed invention cannot be considered novel or cannot be considered to involve an inventive step when the document is taken alone
"E" earlier application or patent but published on or after the international filing date	"Y" document of particular relevance; the claimed invention cannot be considered to involve an inventive step when the document is combined with one or more other such documents, such combination being obvious to a person skilled in the art
"L" document which may throw doubts on priority claim(s) or which is cited to establish the publication date of another citation or other special reason (as specified)	"&" document member of the same patent family
"O" document referring to an oral disclosure, use, exhibition or other means	
"P" document published prior to the international filing date but later than the priority date claimed	

Date of the actual completion of the international search 19 January 2015 (19.01.15)	Date of mailing of the international search report 27 January 2015 (27.01.15)
---	--

Name and mailing address of the ISA/ Japan Patent Office	Authorized officer
---	--------------------

Facsimile No.	Telephone No.
---------------	---------------

INTERNATIONAL SEARCH REPORT

International application No.  
PCT/JP2014/078321

C (Continuation). DOCUMENTS CONSIDERED TO BE RELEVANT

5  
10  
15  
20  
25  
30  
35  
40  
45  
50  
55

Category*	Citation of document, with indication, where appropriate, of the relevant passages	Relevant to claim No.
A	JP 2001-069391 A (Fujitsu Ltd.), 16 March 2001 (16.03.2001), entire text; all drawings & US 2873356 B1	1-7
A	JP 10-023321 A (Tamron Co., Ltd.), 23 January 1998 (23.01.1998), entire text; all drawings (Family: none)	1-7
A	GB 2471145 A (ASH TECHNOLOGIES RESEARCH LTD.), 22 December 2010 (22.12.2010), entire text; all drawings (Family: none)	1-7

**REFERENCES CITED IN THE DESCRIPTION**

*This list of references cited by the applicant is for the reader's convenience only. It does not form part of the European patent document. Even though great care has been taken in compiling the references, errors or omissions cannot be excluded and the EPO disclaims all liability in this regard.*

**Patent documents cited in the description**

- JP 2012151521 A [0004]
- JP 2013230385 A [0050]