



No. 866,520.

PATENTED SEPT. 17, 1907.

C. A. ROCKWELL.  
SWINGING GATE.

APPLICATION FILED APR. 25, 1907.

2 SHEETS—SHEET 2.

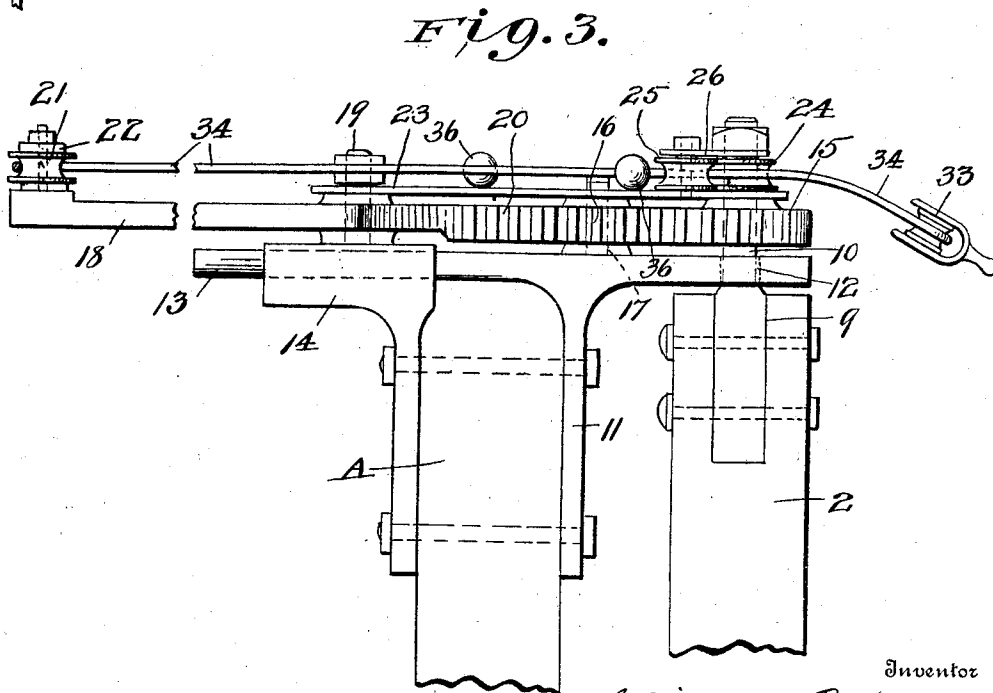
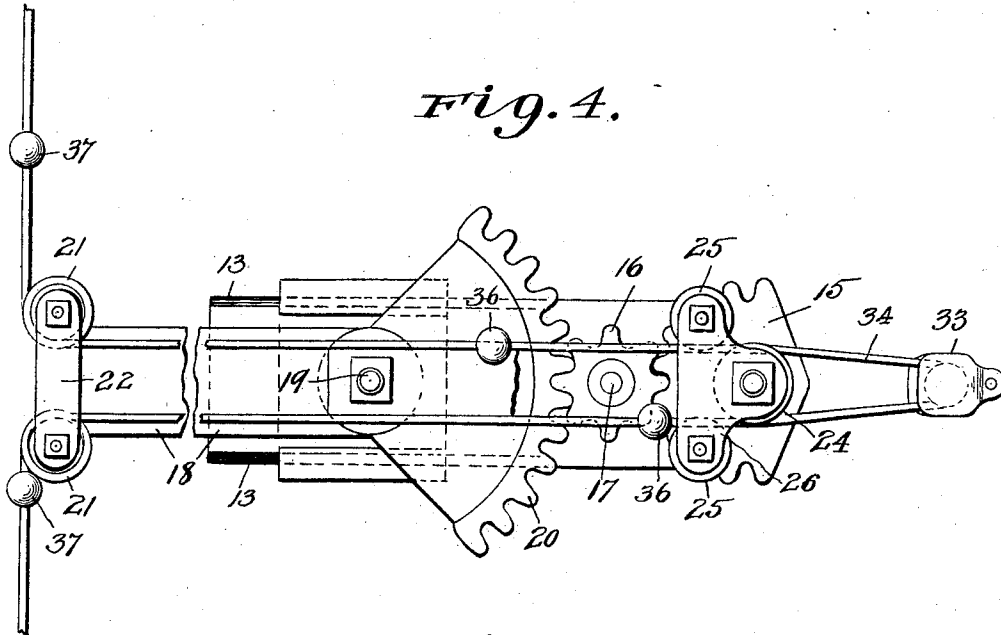

Witnesses

James H. Blackwood  
W. D. Brown

By

Inventor  
Clinton A. Rockwell

James H. Polk

Attorney

# UNITED STATES PATENT OFFICE.

CLINTON A. ROCKWELL, OF WELD COUNTY, COLORADO.

## SWINGING GATE.

No. 866,520.

Specification of Letters Patent.

Patented Sept. 17, 1907.

Application filed April 25, 1907. Serial No. 370,267.

*To all whom it may concern:*

Be it known that I, CLINTON A. ROCKWELL, a citizen of the United States, and a resident of the county of Weld and State of Colorado, have invented certain new and useful Improvements in Swinging Gates, of which  
5 the following is a specification.

My invention relates to swinging gates operated by means of ropes at a distance from the gate; and it has for its object the improvement of the working parts to  
10 the end that the gate is easily and quickly operated either in opening or closing, being latched in either an opened or closed position, so that a pull of the rope is necessary to open it when in a closed position and to close it from an opened position.

15 My invention will be described in detail hereinafter, and illustrated in the accompanying drawings, in which—

Figure 1 is a plan view of my gate and its connected parts; Fig. 2, a side view of the gate, its supporting post  
20 and the latch post for holding it shut; Fig. 3, a side view of the operating parts on an enlarged scale; Fig. 4, a plan view of the operating parts, and Fig. 5, a detail view of the means for supporting the lower end of the gate.

25 In the drawings similar reference characters indicate corresponding parts throughout the several views.

A indicates the hinge-post, B the latch-post for the gate when the gate is closed, C the posts for holding the gate latched in an opened position, and D posts with  
30 cross-pieces E, on which are supported the ends of the operating-rope, hereinafter referred to

The gate 1 has the lower end of its hinge-stile 2 seated in a socket 3, secured to the post A by means of a threaded shank 4 extended through a transverse hole  
35 in said post and having nuts 5 on each side of the post, so as to admit of adjusting the position of the socket 3 relative to the post to insure leveling the gate 1.

6 indicates a pin extending from the center of socket 3 and fitting in hole 7 in the lower end of the stile 2,  
40 and 8 anti-friction-bearings, on which the lower end of the stile rests. Secured to the upper end of stile 3 is a casting 9, having its upper end formed as a stud-shaft 10, journaled in the two-part casting 11, secured to the upper end of post A, one part of said casting 11 being  
45 T-shape, as shown, having one of its cross-arms provided with a hole 12 to receive shaft 10, and its other arm beveled, as shown at 13, to receive a beveled head 14 on the upper end of the other part of the casting. This construction of casting admits its being fitted to  
50 posts of different thicknesses.

15 indicates a segmental gear keyed or otherwise secured to stud-shaft 10, 16 a gear-pinion journaled on a stud-shaft 17, extending upwardly from casting 11 and meshing with segmental gear 15, and 18 a lever-arm

fulcrumed on another stud-shaft or pin 19 on said casting 11. One end of lever-arm 18 is formed with a segmental gear 20, meshing with gear-pinion 16, while the other end, being the outer end, of the arm has two pulleys 21 journaled thereon and held in place by means of a plate 22.  
60

23 indicates a plate secured over the gear elements 15 and 16 and lever-arm 18, 24 a pulley journaled on stud-shaft 10, and 25 other pulleys journaled on plate 23, while 26 indicates a plate secured over pulleys 24 and 25.  
65

27 indicates the latch consisting of a metal rod secured near the lower end of the stile 28 and formed with offsets 29 to seat in latch-sockets 30, secured to the post B, when the gate is in a closed position, or in latch-sockets 31 on the posts C when the gate is  
70 in an opened position. The upper end of the latch 27 extends through the stile 28 and has a rod 32 secured at one of its ends thereto, and 33 is a pulley secured to the other end of the said rod.

34 indicates the operating-rope or cable, extending  
75 from one of the cross-arms E, around one of the pulleys 21 between one of the pulleys 25 and pulley 24, then around pulley 33, back between the other of the pulleys 25 and pulley 24, around the remaining pulley 21 to the cross-arm E on post D at the other side of the  
80 gate.

36 indicates metal knobs secured to the rope or cable between pulleys 21 and 25, and 37 other knobs secured to the rope or cable between pulleys 21 and the ends of cross-arms E.  
85

In operating the gate from a closed position, either end of the rope or cable 34 is pulled. When the knobs 36 and 37 nearest the other end of the rope engage the pulleys 25 and 21, respectively, the pull on the rope serves to first withdraw the latch 27 from engagement  
90 with the latch-sockets 30 and then to swing the lever-arm 18 on stud-shaft 19 and through the gear elements 20, 16, and 15 to swing the gate open away from the operator, the latch-sockets on the post C on that side of the gate opening engaging the latch to hold it in an open position. The gate may be closed by pulling on the rope or cable nearest the post C to which the gate is latched. It will also be understood that the weight of rod 32 and pulley 33 serves to hold the knobs 36 in engagement with pulleys 25 when the gate is either  
100 opened or closed, so as to prevent the ends of the rope or cable 34 from dragging on the ground.

Having thus described my invention, what I claim is—

In combination with a swinging gate, a segmental gear  
105 secured thereto, a gear-pinion meshing with said segmental gear, a lever-arm suitably fulcrumed and having a segmental gear integral therewith and meshing with said

gear-pinion, pulleys journaled on said lever-arm, guide-pulleys suitably journaled, a latch, a rod secured to said latch, a pulley secured to said rod, an operating-rope engaging the pulleys aforesaid, the ends of said rope being  
5 supported at a distance on each side of the gate-opening, knobs secured to said rope between the pulleys on the lever arm, and the guide-pulleys, other knobs secured to the rope between the pulleys on the lever-arm and the ends of the rope, and latch-posts to engage the latch when the gate is

in an opened or closed position, substantially as shown and 10 described.

In witness whereof I have hereunto set my hand in presence of two subscribing witnesses.

CLINTON A. ROCKWELL.

In presence of—  
J. H. NEWELL,  
H. A. LOVEJOY.