

(19) World Intellectual Property  
Organization  
International Bureau



(43) International Publication Date  
10 February 2005 (10.02.2005)

PCT

(10) International Publication Number  
WO 2005/012180 A2

- (51) International Patent Classification<sup>7</sup>: C02F
- (21) International Application Number: PCT/SG2004/000232
- (22) International Filing Date: 2 August 2004 (02.08.2004)
- (25) Filing Language: English
- (26) Publication Language: English
- (30) Priority Data:  
200304231-4 2 August 2003 (02.08.2003) SG

AT, AU, AZ, BA, BB, BG, BR, BW, BY, BZ, CA, CH, CN, CO, CR, CU, CZ, DE, DK, DM, DZ, EC, EE, EG, ES, FI, GB, GD, GE, GH, GM, HR, HU, ID, IL, IN, IS, JP, KE, KG, KP, KR, KZ, LC, LK, LR, LS, LT, LU, LV, MA, MD, MG, MK, MN, MW, MX, MZ, NA, NI, NO, NZ, OM, PG, PH, PL, PT, RO, RU, SC, SD, SE, SG, SK, SL, SY, TJ, TM, TN, TR, TT, TZ, UA, UG, US, UZ, VC, VN, YU, ZA, ZM, ZW.

- (71) Applicant and
- (72) Inventor: GUEH, How Kiap [SG/SG]; Blk 347, Clementi Ave. 5, #05-66, Singapore 120347 (SG).

(84) Designated States (unless otherwise indicated, for every kind of regional protection available): ARIPO (BW, GH, GM, KE, LS, MW, MZ, NA, SD, SL, SZ, TZ, UG, ZM, ZW), Eurasian (AM, AZ, BY, KG, KZ, MD, RU, TJ, TM), European (AT, BE, BG, CH, CY, CZ, DE, DK, EE, ES, FI, FR, GB, GR, HU, IE, IT, LU, MC, NL, PL, PT, RO, SE, SI, SK, TR), OAPI (BF, BJ, CF, CG, CI, CM, GA, GN, GQ, GW, ML, MR, NE, SN, TD, TG).

- (74) Agent: CHONG, Y., F.; PSA Building, P.O. BOX 0399, Singapore 911144 (SG).

Published:  
— without international search report and to be republished upon receipt of that report

- (81) Designated States (unless otherwise indicated, for every kind of national protection available): AE, AG, AL, AM,

For two-letter codes and other abbreviations, refer to the "Guidance Notes on Codes and Abbreviations" appearing at the beginning of each regular issue of the PCT Gazette.

(54) Title: METHOD AND APPARATUS FOR HULL INTEGRATED SEAWATER REVERSE OSMOSIS SYSTEM

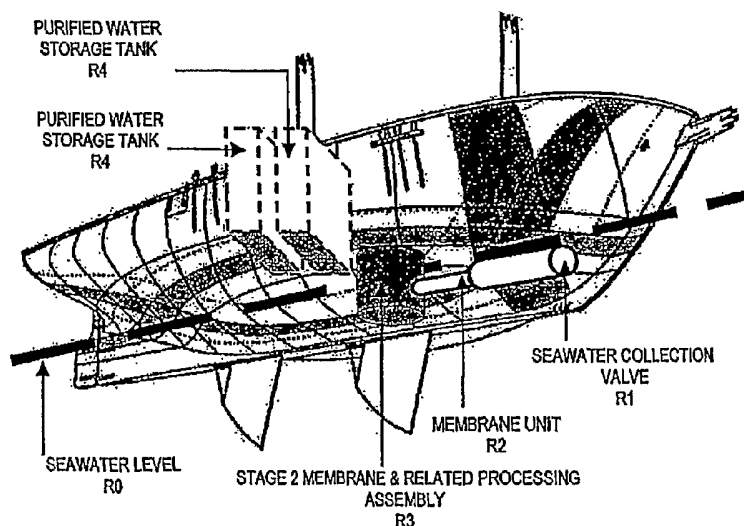


Figure 2 illustrates a perspective diagram of a sea vessel with a valve combined with additional filters and at least 1 membrane to filter seawater incoming via the said valve to yield seawater with a reduced amount of impurities, such as sodium chloride.

(57) Abstract: The present invention relates to a method and apparatus for having a integrated fluid media filtration and membrane unit within the hull of a sea-bound vessel. The vessel's propulsion will drive the flow of seawater into the media filtration and membrane unit. Multiple stages of the passing of seawater via the membrane and/or a series of progressive membranes can be implemented to reduce the level of sodium chloride present in seawater to desirable specifications.

WO 2005/012180 A2

**Method and apparatus for hull integrated seawater reverse osmosis system****FIELD OF THE INVENTION**

- 5 The present invention relates to a method and apparatus for having a integrated fluid media filtration and membrane unit within the hull of a sea-bound vessel. The vessel's propulsion will drive the flow of seawater into the media filtration and membrane unit. Multiple stages of the passing of seawater via the membrane and/or a series of progressive membranes can be implemented to reduce the level of sodium chloride present in seawater to desirable specifications.
- 10 There are a variety of methods and processes that are currently deployed to make use of seawater as a desalination source, thereby creating new avenues whereby drinking water can be processed and utilized.
- 15 One such method is reverse osmosis of seawater, whereby seawater is removed of sodium chloride, and with further processing, including the irradiation of ultraviolet rays to destroy any bacteria or micro-organisms present to yield highly purified water that is suitable for applications that go beyond drinking water.
- 20 It is commonly known that purified water (also called ultra pure water) increases the overall efficiency of turbines in a steam-powered powerplant, and due to the absence of a significant quantity of minerals (including sodium chloride), extends the operating life-span of the individual turbine blades.
- 25 There are already many geographical locations around the world today that are facing chronic shortages of drinkable water.
- Yet, the design, construction and operation of reverse osmosis plants are still expensive and therefore are generally out of the reach of many (in terms of cost of consumption versus the cost of conventional drinking water sources).
- 30 In the Republic of China for example, many regions near industrial zones are faced with the prospect of severe water shortages due to poor water distribution networks, imbalances in the consumption of water by water intensive industries such as semiconductor fabrication etc.
- 35 The quality of water distribution networks cannot be under-estimated, in many cases, the amount of water available to a population of consumers and industrial users are greatly impacted by the efficiency of such networks.
- 40 Leaky pipes, corroded gaskets and faulty pipe pumps reduce the absolute water supply that can be distributed at any one time.
- However, the repair and maintenance of these networks is not easy nor affordable.
- 45 From an economic stand-point, the decision to distribute water via water pipelines or having vessels storing the water into tanks (and having them transported to the location for consumption) may be determined by factors such as cost, operating capability, consumption range etc.
- 50 The use of oil pipelines and oil tankers is one such example.
- The price of drinkable water is indeed on par, if not more costly than crude oil in areas of the Middle East, making it economical to build desalination plants to make use of seawater for conversion into drinking water.
- 55 There is already a growing trend in many places around the world whereby the price point of water may match the cost of crude oil imports (comparison by absolute volume).

It is therefore possible for sea-going vessels to transport purified water from an oil importing region to an oil exporting region, and return oil, in exchange for water, to the oil importing region.

5

It is also foreseeable that sea-going vessels may make use of the seawater to convert into purified water for storage on-board these vessels, for export to far flung regions, while making the cost of such water within reach of many (this is due to the multiple consumption markets that is within reach of the sea-going vessel capable of desalinating sea-water into fresh water).

10

The ability for water desalination systems to be mobile reduces the overall cost of purified water, by maximizing the reach of potential consumers while at the same time, reducing the need for capital expenditure in individual regions where desalinated water is desirable.

## 15 SUMMARY OF THE INVENTION

It is object of the present invention to provide for a method and apparatus for having a integrated fluid media filtration and membrane unit within the hull of a sea-bound vessel. The vessel's propulsion will drive the flow of seawater into the media filtration and membrane unit. Multiple stages of the passing of seawater via the membrane and/or a series of progressive membranes can be implemented to reduce the level of sodium chloride present in seawater to desirable specifications.

20

The present invention consists of a sea-going vessel, or any device capable of propulsion or floatation in areas where seawater or naturally occurring water is available.

25

The said vessel will be constructed with suitable valves or openings capable of intake of seawater during the vessel's propulsion.

In addition, the said vessel constructed with the said valves will also be capable of intake of seawater in a stationary position, having the said valve to be located within the level of seawater surrounding the said vessel.

30

The main function of the valves incorporated into the sea vessel hull is primarily to accept seawater via pipes connected to the said valves for routing of the said seawater into a suitable seawater storage tank.

The valves will be operated by means of a suitable prime mover such as an electric motor, AC alternator, or powerplant to ensure that the valve can open or close the valve opening to control the rate of seawater intake.

35

The construction of the valve may be constructed to be flush with the surface of the sea vessel hull, and may, optionally, include hardware that can prevent solid objects or other form of large particles to be filtered away from the valve opening.

40

Alternatively, the valve may be constructed to be protruding from either the hull surface, or surface area perpendicular to and/or along the length of the sea vessel.

The present invention will also include the construction of filters within pipes connected to the said valves to remove any media (or particles) that may accompany the intake of seawater via the valve.

45

The said pipes may also be fitted with membranes that can suitably remove a specific amount of sodium chloride and/or other impurities from the seawater being brought into via the said valves incorporated into the hull of the sea vessel.

### BRIEF DESCRIPTION OF THE DRAWINGS

Illustrative embodiments of the present invention will now be described, by way of example, with reference to the accompanying drawings, in which:

5

Figure 1 illustrates a perspective diagram of a sea vessel with a valve fitted onto the surface of its hull.

10

Figure 2 illustrates a perspective diagram of a sea vessel with a valve combined with additional filters and at least 1 membrane to filter seawater incoming via the said valve to yield seawater with a reduced amount of impurities, such as sodium chloride.

15

Figure 3 illustrates filtered seawater incoming from the valve fitted onto the hull of the sea vessel, being routed onto a assembly of devices capable of performing reverse osmosis to further purify the filtered seawater.

20

Figure 4 illustrates a side view diagram of the major components and devices that are required for the processing and purification of seawater collected from valves constructed onto the hull surface of a sea vessel.

Figure 5 illustrates the forward direction induced from the mechanical work imposed by a suitable powerplant unit installed within the sea vessel, enabling seawater to be fed into the valves constructed to accept the intake of seawater.

25

Figure 6 illustrates how a suitable pump can be powered by auxiliary batteries charged by alternators connected to the sea vessel powerplant, enabling the said pump to continue feeding seawater into the pipes connected to the valves fitted onto the surface of the sea vessel hull, in the event whereby the sea vessel is stationary.

30

Figure 7 illustrates the construction of a valve assembly incorporated with a suitable reverse osmosis membrane for processing of seawater (stage 1) in a typical reverse osmosis process.

35

Figure 8 illustrates the construction of a valve assembly capable of routing seawater being treated by at least 1 reverse osmosis membrane, to a second valve and membrane assembly to further pass the said treated water to a second pass of another similar reverse osmosis membrane.

### DETAILED DESCRIPTION OF THE PREFERRED EMBODIMENTS

40

Figure 1 illustrates a perspective diagram of a sea vessel with a valve fitted onto the surface of its hull.

The vessel's hull 20 is partially submerged to the seawater level 10. Beneath the seawater level 10, a pre-treatment filter valve 30 is fitted to the vessel's hull 20.

45

As the vessel moves along the water, jets of seawater flows into the said valve and directed into the pass reverse osmosis unit 40 installed in the vessel's body.

50

Figure 2 illustrates a perspective diagram of a sea vessel with a valve combined with additional filters and at least 1 membrane to filter seawater incoming via the said valve to yield seawater with a reduced amount of impurities, such as sodium chloride.

55

An improved embodiment is to install additional filters after the seawater collection valve R1. The seawater is passed into a membrane unit R2 and to further filter the seawater a second stage of processing R3 is added to further desalinate the seawater.

After the seawater water is processed, the purified water is stored into storage tanks R4 for

storage and eventual consumption.

5 Figure 3 illustrates filtered seawater incoming from the valve fitted onto the hull of the sea vessel, being routed onto a assembly of devices capable of performing reverse osmosis to further purify the filtered seawater

10 In yet another improved embodiment, the untreated seawater is channelled through a pre-treatment filter valve G1, which segregates the unwanted solid matters from the seawater. The said solid matters may be organic matter like fish or inorganic matters like man-made rubbish floating in the seawater. The filtration also prevents the clogging to occur in the membrane unit G3.

15 Figure 4 illustrates a side view diagram of the major components and devices that are required for the processing and purification of seawater collected from valves constructed onto the hull surface of a sea vessel

20 The seawater is first collected by the valve A-1 located at the front hull of the vessel. The system pump C-3 is required to pump the seawater into respective chambers for treatment. Treatment of seawater takes place at the membrane to 03 and ultra-violet irradiation unit B-2.

The vessel and the treatment plant is powered by a power plant located in the vessel with auxiliary batteries to serve as backup D-4 as well as the kick-starting of the treatment process.

25 After treatment of seawater, the treated water is pumped into storage tanks E-5.

Figure 5 illustrates the forward direction induced from the mechanical work imposed by a suitable power plant unit installed within the sea vessel, enabling seawater to be fed into the valves constructed to accept the intake of seawater

30 The seawater flows into the valve as shown by the arrow 3000 whereby the vessel is partially submerged in the seawater. The vessel power is powered by the power plant 1000 in order to propel itself across the sea.

35 Figure 6 illustrates how a suitable pump can be powered by auxiliary batteries charged by alternators connected to the sea vessel powerplant, enabling the said pump to continue feeding seawater into the pipes connected to the valves fitted onto the surface of the sea vessel hull, in the event whereby the sea vessel is stationary

40 When the vessel is stationary, the auxiliary batteries s4 will kick-start the pump s5 and pumped the seawater into the valve to carry on the treatment process.

45 Figure 7 illustrates the construction of a valve assembly incorporated with a suitable reverse osmosis membrane for processing of seawater (stage 1) in a typical reverse osmosis process.

50 Figure 8 illustrates the construction of a valve assembly capable of routing seawater being treated by at least 1 reverse osmosis membrane, to a second valve and membrane assembly to further pass the said treated water to a second pass of another similar reverse osmosis membrane.

**Modifications within the spirit and scope of the invention may readily be effected by persons skilled in the art. It is to be understood, therefore, that this invention is not limited to the particular embodiments described by way of example hereinabove.**

**CLAIMS**

1. A system and method for a plurality of sea going vessels to capture seawater, process the said seawater into a desired condition, store the said processed seawater onboard such said vessels, and sending such vessels to a plurality of locations for the purposes of distributing the processed water
2. A system and method for a plurality of sea going vessels to be designed specifically for the purpose of capturing seawater, processing said seawater into a desired condition, and storing the processed water onboard via suitable storage devices
3. A system and method for a plurality of sea going vessels to be designed for the purposes of capturing seawater, processing said seawater into a desired condition, storing the processed water onboard, and distributing the said processed water to a plurality of geographical locations having suitable or appropriate facilities to allow the said distribution to take place
4. A system and method for a sea going vessel to have routing mechanisms within the vessel to capture seawater from either the vessel water intake valves, also called sea chests, or capturing seawater originally used for vessel engine cooling, about to be discharged, for the purposes of routing the captured seawater into a suitable water processing device to process the said captured seawater into a desired condition
5. A method and apparatus for a routing device to be fitted at a suitable location within any sea going vessel in order to capture seawater used for vessel engine cooling, to be discharged if said device is not fitted, for the purposes of capturing and routing said seawater to a water processing facility onboard the said vessel
6. A method and apparatus for a routing device to be fitted or be connected to a seawater engine cooling discharge outlet, for the purposes of capturing the said seawater discharge, processing the said discharge into a desired condition, and subsequently storing the processed water onboard via suitable storage devices

7. A system and method for a sea going main vessel to capture seawater, process the said seawater into a desired condition, store the said processed seawater onboard the said main vessel, allow a plurality of smaller vessels to further distribute the said processed seawater from the main vessel to a plurality of locations or a single destination
- 5
8. A system and method for a sea going vessel to be equipped with suitable seawater processing facility or plant, coupled with suitable storage tanks onboard, for the purposes of desalinating seawater into a desired condition, storing the processed water into the said tanks, and distributing the said processed water to a plurality of markets which may be in geographically separate locations
- 10
9. A system and method for a sea going vessel to be designed to capture seawater from either its existing seawater intake valves or sea chests, or from its vessel engine's seawater cooling discharge outlet, or a combination thereof, for the purposes of using the said captured seawater in a water processing device to process the said seawater into processed water of a desired condition, and storing the said processed water onto storage tanks onboard the said vessel, for eventual distribution to a plurality of markets
- 15
10. A method and apparatus for a seawater desalination system to be housed in standard cargo containers, for mounting of the said container onto a sea going vessel, for the purposes of making use of captured seawater from the said vessel to the said desalination system
- 20
11. A method and apparatus as claimed in claim 10, where additional cargo containers are adapted to store processed water that is output from the seawater desalination system
- 25
12. A method and apparatus as claimed in claims 10-11, where specially adapted cargo containers can receive processed water from a seawater desalination system, and be mounted onboard a sea going vessel, and be subsequently dismantled from the said vessel to an inland container loading/unloading facility
- 30
13. A method and apparatus as claimed in claim 12, where said cargo containers can be immediately be removed from the said vessel upon

receiving a designated amount of processed water from the said vessel mounted seawater desalination system

- 5 14. A system and method for capturing seawater from a sea-going vessel, allowing the said seawater to be routed to a seawater desalination unit that is constructed and housed within a standard 20 or 40 foot cargo container, allowing the said desalination unit to process the said seawater to a desired specification, sending the processed water to one or more 20 or 40 foot cargo container that is capable of storing the said liquid for loading and unloading to and from the said vessel to any  
10 inland cargo container loading and unloading facility
- 15 15. A system and method for a sea going vessel to be constructed and equipped with an auxiliary powerplant to specifically capture, route and process seawater into processed water of a desired condition, then storing the said processed water on-board via suitable storage facilities for the purpose of distributing the said processed water to a plurality of distribution points/locations
- 20 16. A system and method as claimed in claim 14, including allowing either the main powerplant of a sea going vessel, the auxiliary powerplant, or a combination thereof, to specifically capture, route, and process seawater into processed water of a desired condition, then storing the said processed water on-board via suitable storage facilities for the purpose of distributing the said processed water to a plurality of distribution points/locations
- 25 17. A system and method for a sea-going vessel to be constructed and equipped with a solar-panel assembly, auxiliary powerplant unit, water desalination system, and water storage units, for the purposes of capturing seawater for processing and subsequent distribution to the plurality of locations, comprising of the following steps;
- 30 Converting solar energy gathered by the solar panel assembly on-board the said vessel into electrical energy;
- Charging said electrical energy into the auxiliary powerplant unit;

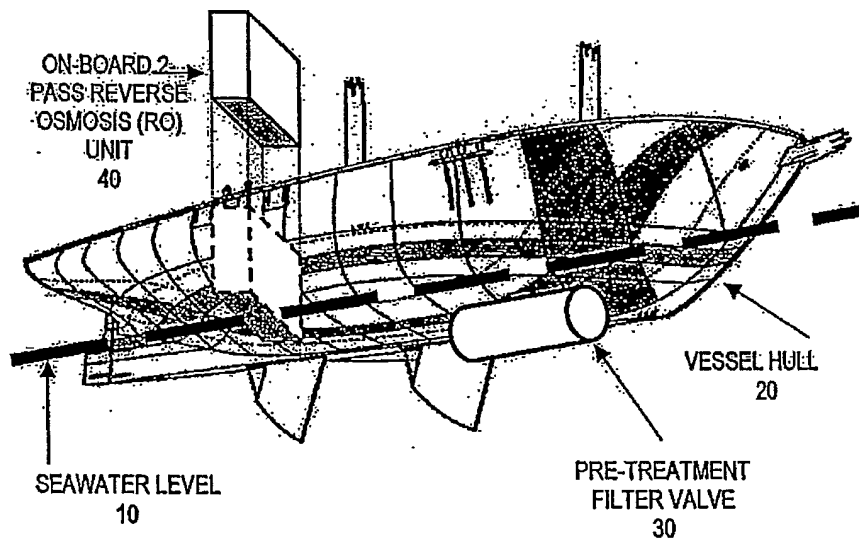
- Capturing seawater using the vessel's sea chests, or vessel's engine seawater cooling outlet, or a combination thereof;
- Sending the captured seawater to the vessel's desalination system;
- Driving the operation of the desalination system using the charged energy from the said powerplant unit;
- Storing the processed water from the said system to the vessel's water storage units;
- Distributing the said processed water to a plurality of inland facilities equipped to allow the said vessel's design purpose
- 10 18. A method and apparatus for a sea-going vessel to be utilized for the purposes of collecting seawater comprising of the following steps;
- Collecting seawater from the vessel's seawater intake valves, also called sea chests;
- Collecting seawater from the outlet of the seawater engine cooling unit of the said vessel;
- Collecting seawater from either the vessel's sea chest or the vessel's engine cooling unit seawater outlet, or a combination thereof;
- Sending the said seawater to a on-board seawater desalination and/or de-salting system;
- 20 Storing the processed water from the said desalination and/or de-salting system to a series of water storage tanks onboard the said vessel;
- Distributing the said stored water to a plurality of locations
- 25 19. A method and apparatus for a sea-going vessel to be constructed with additional sea chests for capturing seawater during the vessel's motion/propulsion, for the purposes of processing the said captured seawater comprising of the following steps;
- Capturing seawater during the vessel's motion/propulsion;

Sending said seawater to an on-board seawater desalination system or the like;

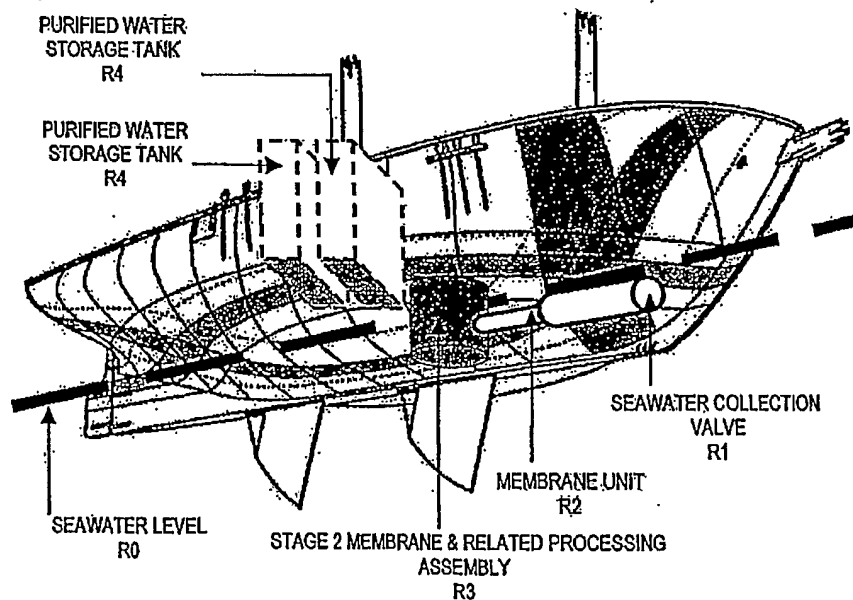
Processing said seawater by the said system to a desired specification;

Sending the processed water to on-board storage tanks;

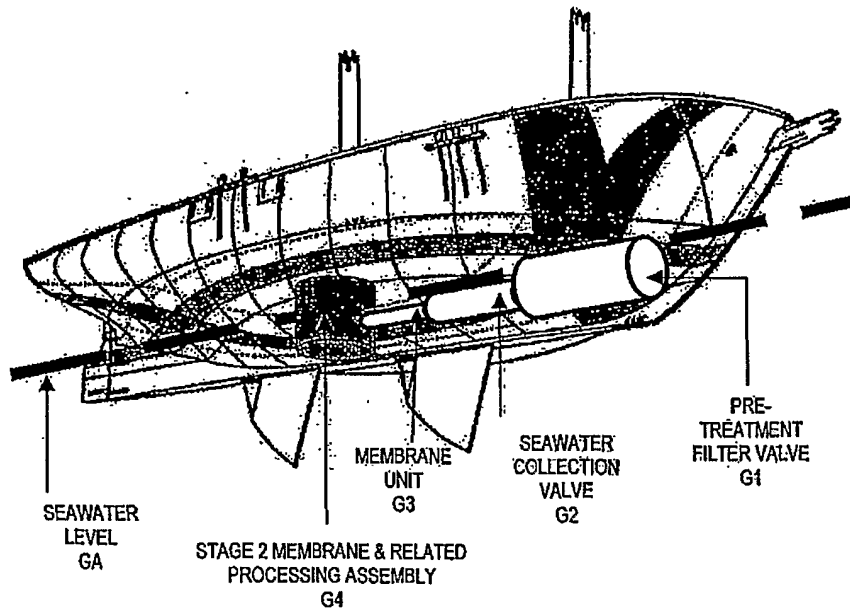
5       Distributing the said water to a plurality of locations by suitable means between the said vessel and an inland facility



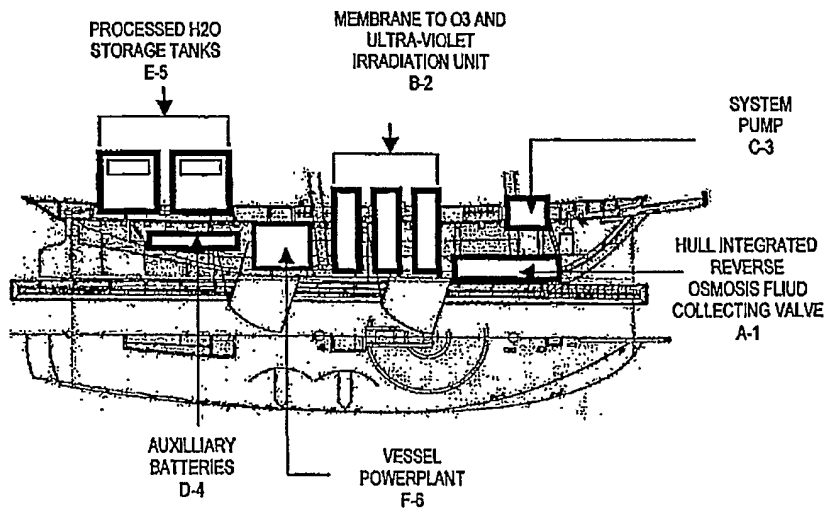
**Figure 1 illustrates a perspective diagram of a sea vessel with a valve fitted onto the surface of its hull.**



**Figure 2 illustrates a perspective diagram of a sea vessel with a valve combined with additional filters and at least 1 membrane to filter seawater incoming via the said valve to yield seawater with a reduced amount of impurities, such as sodium chloride.**

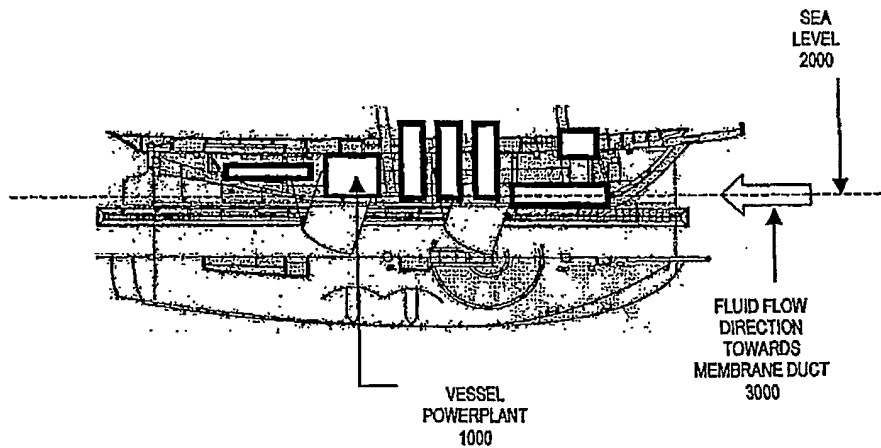


**Figure 3 illustrates filtered seawater incoming from the valve fitted onto the hull of the sea vessel, being routed onto a assembly of devlces capable of performing reverse osmosis to further purify the filtered seawater**

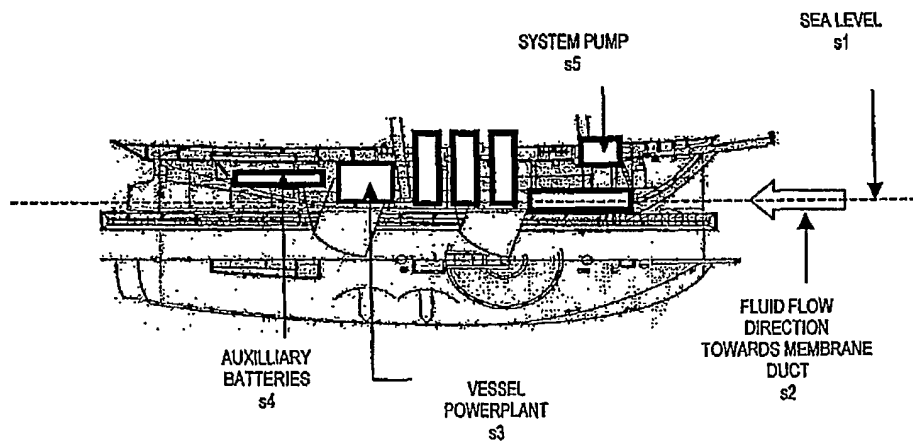


**Figure 4 illustrates a side view diagram of the major components and devices that are required for the processing and purification of seawater collected from valves constructed onto the hull surface of a sea vessel**

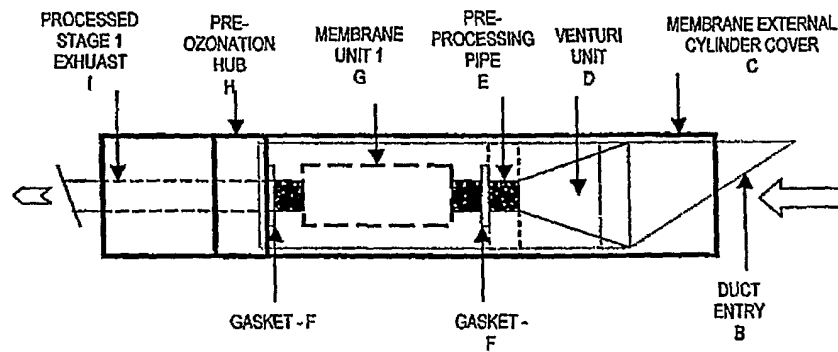
3 / 4



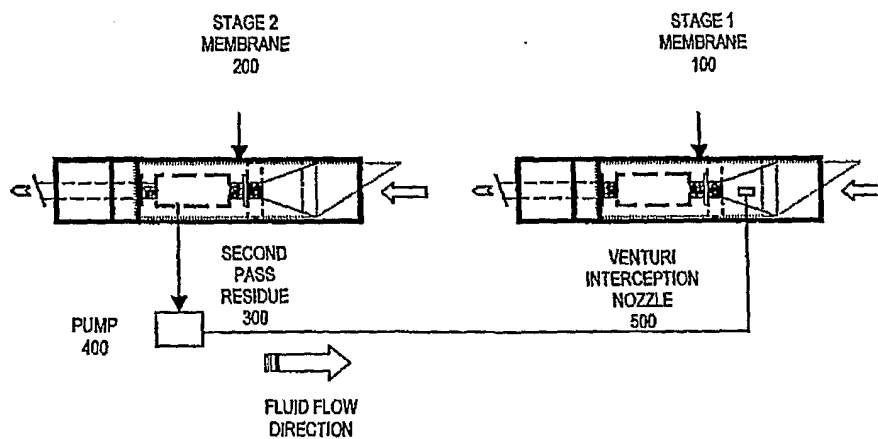
**Figure 5 illustrates the forward direction induced from the mechanical work imposed by a suitable powerplant unit installed within the sea vessel, enabling seawater to be fed into the valves constructed to accept the intake of seawater**



**Figure 6 illustrates how a suitable pump can be powered by auxiliary batteries charged by alternators connected to the sea vessel powerplant, enabling the said pump to continue feeding seawater into the pipes connected to the valves fitted onto the surface of the sea vessel hull, in the event whereby the sea vessel is stationary**



**Figure 7 illustrates the construction of a valve assembly incorporated with a suitable reverse osmosis membrane for processing of seawater (stage 1) in a typical reverse osmosis process**



**Figure 8 illustrates the construction of a valve assembly capable of routing seawater being treated by at least 1 reverse osmosis membrane, to a second valve and membrane assembly to further pass the said treated water to a second pass of another similar reverse osmosis membrane**