

L. J. CRECELIUS.
POSITIVE LOCK CLUTCH.
APPLICATION FILED JAN. 4, 1904.

2 SHEETS—SHEET 1.

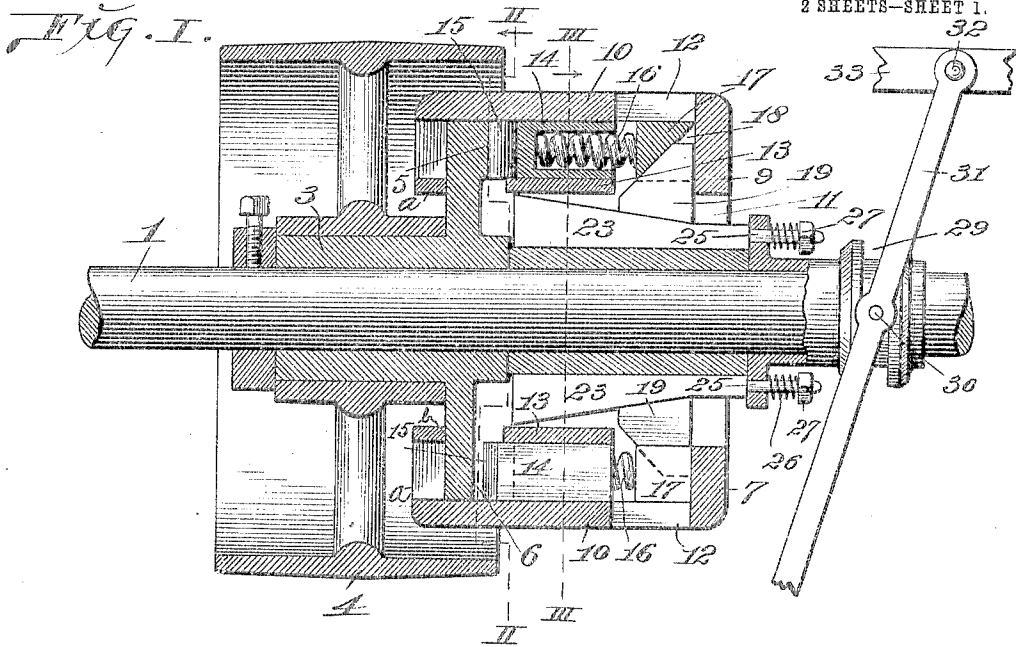

Fig. II.

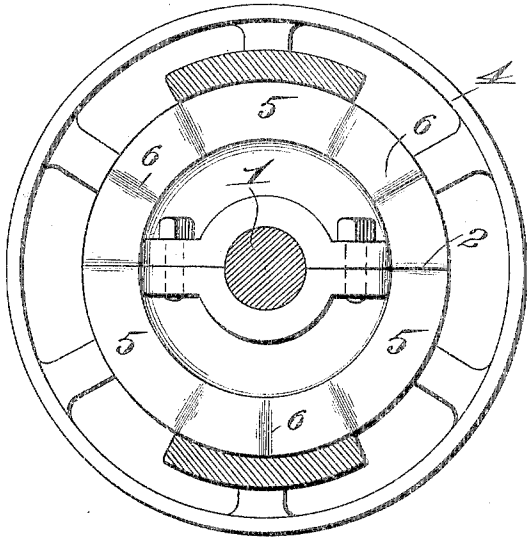
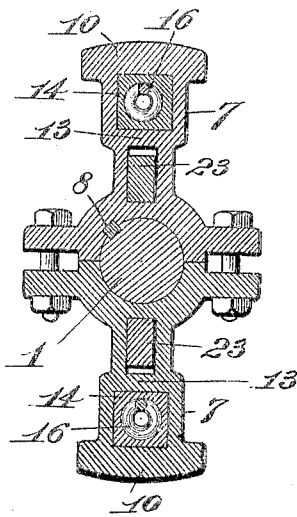

Fig. III.



attest:—
M. Smith,
 Blanche Hogan.

Inventor:—
 L. J. Crecelius:—
 By *Knigh Bros.*
 attys.

L. J. CRECELIUS.
POSITIVE LOCK CLUTCH.
APPLICATION FILED JAN. 4, 1904.

2 SHEETS—SHEET 2.

Fig. IV.

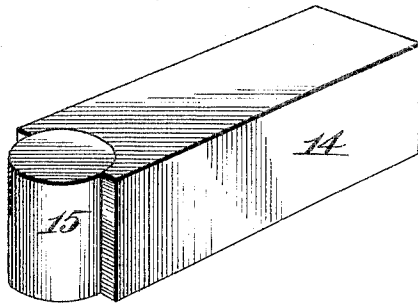

Fig. V.

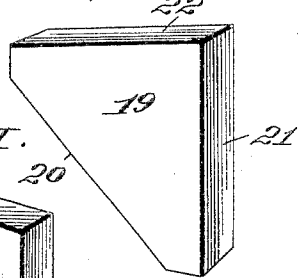

Fig. VI.

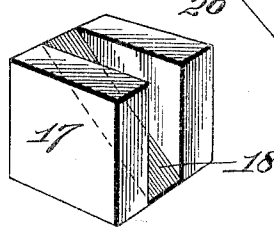

Fig. VII.

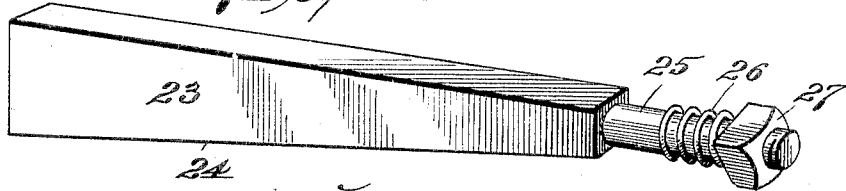

Fig. VIII.

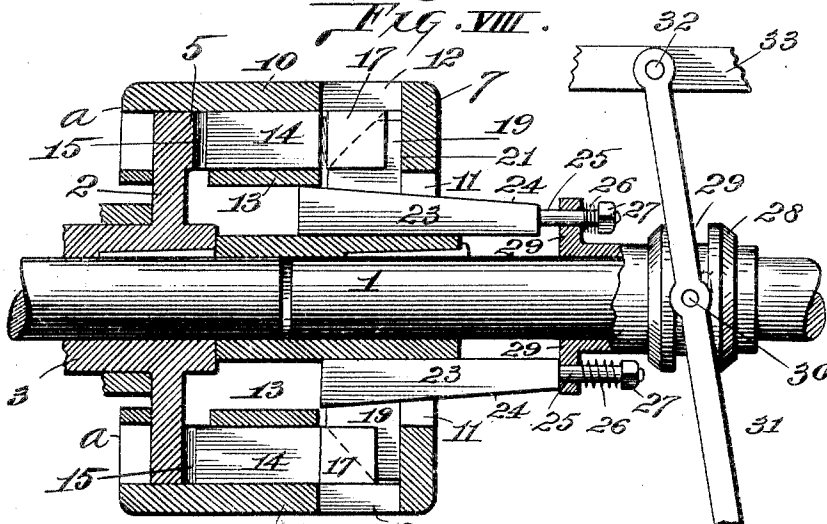
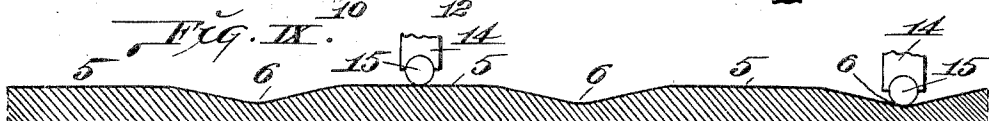

Fig. IX.



attest:—
M. Smith
Blanche Hogan.

Inventor:—
L. J. Crecelius:—
By *Arrigan & Co.* atty's.

UNITED STATES PATENT OFFICE.

LOUIS J. CRECELIUS, OF ST. LOUIS, MISSOURI, ASSIGNOR TO FREDERICK
J. FEINEMAN, OF ST. LOUIS, MISSOURI.

POSITIVE-LOCK CLUTCH.

SPECIFICATION forming part of Letters Patent No. 793,920, dated July 4, 1905.

Applicator filed January 4, 1904. Serial No. 187,711.

To all whom it may concern:

Be it known that I, LOUIS J. CRECELIUS, a citizen of the United States, residing in the city of St. Louis and State of Missouri, have
5 invented certain new and useful Improvements in Positive-Lock Clutches, of which the following is a full, clear, and exact description, reference being had to the accompanying drawings, forming part of this specification.

10 My invention relates to a positive-lock clutch which can be started at a gradual speed and will hold any load up to its breaking strain without readjustment.

This clutch can be made as a single unit or
15 split to permit of its being placed readily at any desired point on a shaft when used on power-transmitting devices, such as pulleys or driving-wheels. The clutch is also applicable to the meeting ends of two shafts to com-
20 municate motion from one to the other.

By my invention I dispense with the commonly-known toggle-levers and costly adjustment of parts, my object being, aside from the positive hold, also the cheapening of cost of
25 construction to enable general adoption.

My invention consists in features of novelty hereinafter fully described, and pointed out in the claims.

Figure I is a longitudinal section of my
30 clutch unlocked. Fig. II is a cross-section taken on line II II, Fig. I, with the parts shown in elevation looking in the direction of the arrow on said line. Fig. III is a cross-
35 section taken on line III III, Fig. I. Fig. IV is a perspective view of one of the oscillating lock-blocks arranged for engagement with the cam-wheel of the clutch. Fig. V is a perspective view of one of the regulating-wedges of the clutch. Fig. VI is a perspective view of
40 one of the lock-blocks. Fig. VII is a perspective view of one of the operating-wedges. Fig. VIII is a longitudinal section of the clutch, showing the parts in the position assumed when the clutch is locked. Fig. IX is
45 a diagrammatical view of a portion of the working face of the cam-wheel and the ends of the oscillating lock-blocks that operate in connection therewith.

1 designates a shaft on which my clutch is
50 shown mounted.

2 is a cam-wheel of split form, (see Fig. II,) having a hub 3 that is loosely mounted on the shaft 1 and which may carry a pulley 4, as shown in Figs. I and II, or other power-transmitting devices to travel with the cam-wheel
55 in its rotation. The pulley 4 is of split form, so that it may be readily applied to the hub of the cam-wheel after the sections of said wheel have been assembled on a shaft. The working face of the cam-wheel 2 is furnished
60 with a plurality of crowns or high points 5 and a plurality of dips or low points 6, located at intervals and alternating, as seen in Figs. I, II, VIII, and IX. The function of these crowns and dips will hereinafter appear.
65

7 designates a sectional clutch-frame, as seen in Figs. I, III, and VIII, which is held from rotation on the shaft 1 by any suitable means, such as a key 8. (Shown on Fig. III.) The frame is chambered interiorly, and it com-
70 prises an end 9 and side arms 10. In the end 9 of the frame are apertures 11, and in the arms 10 are apertures 12.

13 represents webs extending longitudinally and transversely within the frame 7 and
75 spaced apart from the arms 10, as seen in Figs. I, III, and VIII.

14 designates oscillating lock-blocks, preferably two in number, reciprocatingly positioned between the frame-arms 10 and webs
80 13. The forward ends of these oscillating blocks oppose the working face of the cam-wheel 2, and in said forward ends are seated antifriction-rollers 15. The oscillating lock-
85 blocks 14 are recessed, as seen in Figs. I and III, and seated therein are expansion-springs 16, that are preferably of considerable strength. 17 represents lock-blocks located at the rear of the oscillating lock-blocks 14 and between which and said oscillating lock-
90 blocks the springs 16 are seated. Each of these lock-blocks is provided with a diagonal groove 18. (See Figs. I and VI.)

19 represents regulating-wedges having inclined working faces 20, (see Figs. I and V,)
95 that operate within the grooves of the lock-blocks 17.

23 designates reciprocating operating-wedges provided with slightly-inclined working faces 24 and positioned between the hub of
100

the frame 7, on which they ride, and the regulating-wedges 19. The working faces 24 of these operating-wedges bear against the working edges 22 of the regulating-wedges 19. The operating-wedges extend through the apertures 11 in the frame end 9, and these wedges taper toward a point in an upward direction, as seen in Figs. I, VII, and VIII. Each operating-wedge is provided with a spring 26 at its small end 25. These springs 26 are of less resistance than the springs 16 located between the oscillating lock-blocks 14 and lock-blocks 17.

28 designates a shift-collar loosely positioned on the shaft 1. (See Figs. I and VIII.) This collar has a flange 29, that is apertured to receive the operating-wedge ends 25, which operate loosely therein. This flange serves as bearing for the springs 26, the opposite ends of which bear against the nuts 27. In the shift-collar 28 is an annular groove 29', that receives the pins 30 of a shift-lever 31, having one of its ends pivoted at 32 to a suitable support 33, that may be of any desirable form.

In the practical use of my clutch the operation is as follows: The clutch-frame 7 being fixed to the shaft rotates therewith when the shaft is in motion. When the clutch is to be thrown into operation, the shift-lever 31 is thrown outwardly in a direction away from the clutch-frame 7, and the shift-collar 28 is thereby moved in a direction corresponding to the movement of the shift-lever. As a consequence the operating-wedges 23 are reciprocated forwardly in bearing engagement with the regulating-wedges 19, thereby moving said regulating-wedges outwardly, during which movement the working faces 20 of the regulating-wedges travel with contact against the lock-blocks 17 to force them rearwardly in a direction toward the oscillating blocks 14. The result is that pressure is exerted against the springs 16 to carry the oscillating blocks 14 rearwardly toward the cam-wheel 2, against which the rollers 15 at the rear ends of the oscillating blocks bear. The rollers are therefore moved into engagement with the working face of the cam-wheel 2, so that they will ride on the crowns 5 and into the dips 6 of said cam-wheel working face. During the rotation of the clutch-frame 7 the antifriction-rollers 15 when moved inwardly travel in a circuit on the working face of the cam-wheel and alternately ride onto the crowns 5 and into the dips 6, thereby causing a reciprocation of the oscillating blocks 14, due to the inward and outward movement imparted to the antifriction-rollers by the cam working face and the springs at the front of the oscillating blocks. During this action one of the antifriction-rollers 15 is traveling on a crown of the cam working face, while the other antifriction-roller is traveling in a dip of said working face, as diagrammatically illustrated in Fig. IX, and this condition is maintained, due to the positions of the rollers on said working

face being changed from a crown to a dip in alternation. As the operating-wedges 23 are drawn forwardly resistance to the movement of one of them in alternation will be constantly maintained, due to the corresponding oscillating block antifriction-roller moving onto a crown of the cam-wheel working face, and therefore when the shift-collar 28 is drawn forwardly the spring 26 corresponding to said operating-wedge will be compressed, as seen at the upper side of Fig. VIII. At this time the other antifriction-roller associated with the second oscillating block 14 being positioned in a dip of the cam working face no resistance is offered to the forward movement of the corresponding operating-wedge 23, and said operating-wedge remains in a fixed position in so far as longitudinal movement thereof is concerned. Immediately upon the antifriction-roller of the oscillating block first referred to passing into a dip of the cam working face resistance to the movement of the first operating-wedge is eliminated, and the expansion-spring 26 corresponding to said operating-wedge acts to move the operating-wedge forwardly, thereby imparting outward movement to the regulating-wedge 19, by virtue of which the lock-block 17 is carried rearwardly. A further movement outwardly of the shift-collar 28, together with these movements of the parts, is occasioned in alternation with respect to the oscillating blocks 17 and the members by which they are actuated, with the result that the antifriction-rollers 15 are carried gradually into firmer contact with the working face of the cam-wheel 2 until such contact becomes sufficiently intense to lock the antifriction-rollers against the working face of the cam-wheel, thereby locking the clutch positively. The frame 7 on its opposite end has an angular inwardly-extending projection *a*, which answers as a grip to hold against the smooth face *b* of the cam-wheel, as shown in Figs. I and VIII, thus causing a perfect grip on the periphery of the cam-wheel by the locking device referred to. The operation of releasing the clutch is very simple, as it is only necessary to move the shift-collar 28 rearwardly, thereby throwing its flange into engagement with the forward ends of the operating-wedges 23, when said operating-wedges will be readily thrown inwardly in the frame 7 to relieve the pressure exerted thereby against the regulating-wedges 19. When this is done, pressure against the lock-blocks 17 is removed and the oscillating blocks 14 and springs interposed between said lock-blocks and oscillating blocks are freed from restraint, leaving a free path for the travel of the cam-wheel, as shown in Fig. I.

I have shown and described my clutch as having a pulley arranged in connection therewith in Fig. I; but it is obvious that the ends of two shafts may be operatively united by it for the transmission of power from one to the

other, where the cam-wheel 2 is located upon the end of one shaft and the clutch-frame 7 and the parts associated therewith are mounted upon the end of the other shafts, as shown in Fig. VIII.

I claim as my invention—

1. A clutch comprising a cam having a working face, locking means arranged to be gradually moved into contact with said cam working face, and wedge mechanism for holding said locking means positively to said cam working face after continued movement thereof, substantially as set forth.

2. A clutch comprising a cam having a wavy working face, locking means arranged to be gradually moved into contact with said cam working face, and wedge mechanism for holding said locking means positively to said cam working face after continued movement thereof, substantially as set forth.

3. A clutch comprising a cam having a wavy working face, a reciprocating member for gradual movement to said cam working face, and wedge mechanism for shifting said reciprocating member toward said cam working face and finally holding said member to said face, substantially as set forth.

4. A clutch comprising a cam having a working face provided with a plurality of crowns and dips intervening between said crowns, a reciprocating member for gradual movement into contact with said cam working-face crowns and into said dips, means for actuating said reciprocating member, and a spring associated with said last-named means arranged to permit play of a portion thereof during the act of reciprocating said member, substantially as set forth.

5. In a clutch, a locking device composed of a cam-wheel 2, oscillating blocks 14, lock-block 17, regulating-wedge 19, and operating-wedges 23, substantially as described.

6. In a clutch, the combination with a shaft, of a cam-wheel on said shaft having a working face provided with a plurality of crowns and dips intervening between said crowns, a pair of reciprocatory members for movement to said cam working-face crowns and dips, a member fixed to a shaft in which said reciprocatory members are positioned, and means whereby said reciprocatory members are moved independently and alternately toward the working face of said cam, substantially as set forth.

7. In a clutch, the combination with a shaft, of a cam-wheel on said shaft and having an undulatory working face, a plurality of reciprocatory members, means fixed to a shaft and carrying said reciprocatory members, means for moving said members toward the working face of said cam-wheel, and springs interposed in said reciprocatory moving means, substantially as set forth.

8. In a clutch, the combination with a shaft, of a cam-wheel on said shaft and having an

undulatory working face, a plurality of reciprocatory members, means fixed to a shaft and carrying said reciprocatory members, means for exerting pressure against said reciprocatory members, and an operating-wedge for actuating said pressure-exerting means, substantially as set forth.

9. In a clutch, the combination with a shaft, of a cam-wheel on said shaft, and having an undulatory working face, a plurality of reciprocatory members, means fixed to a shaft and carrying said reciprocatory members, means for exerting pressure against said reciprocatory members, an operating-wedge for actuating said pressure-exerting means, and means associated with said operating-wedge for yieldingly resisting movement thereof, substantially as set forth.

10. In a clutch, the combination with a shaft, of a cam-wheel on said shaft and having an undulatory working face, a plurality of reciprocatory members, means fixed to a shaft and carrying said reciprocatory members, an operating-wedge for actuating said pressure-exerting means, and a spring associated with said operating-wedge to be placed under tension during the movement of the operating-wedge, substantially as set forth.

11. In a clutch, the combination of a cam-wheel having an undulatory working face, a frame in proximity with said cam-wheel, an oscillating block in said frame for movement toward said cam working face, a lock-block adjacent to said oscillating block to actuate it, and means for moving said lock-block, substantially as set forth.

12. In a clutch, the combination of a cam-wheel having an undulatory working face, a frame in proximity with said cam-wheel, an oscillating block in said frame for movement toward said cam working face, a lock-block adjacent to said oscillating block to actuate it, a spring interposed between said oscillating block and lock-block, and means for moving said lock-block, substantially as set forth.

13. In a clutch, the combination of a cam-wheel having an undulatory working face, a frame in proximity to said cam-wheel, an oscillating block in said frame for movement toward said cam working face, a lock-block for imparting movement to said oscillating block, a regulating-wedge having engagement with said lock-block, and means for actuating said regulating-wedge, substantially as set forth.

14. In a clutch, the combination of a cam-wheel having an undulatory working face, a frame in proximity to said cam-wheel, an oscillating block in said frame for movement toward said cam working face, a lock-block for imparting movement to said oscillating block, a regulating-wedge having engagement with said lock-block, and an oscillating wedge for moving said regulating-wedge, substantially as set forth.

15. In a clutch, the combination of a cam-

- wheel having an undulatory working face, a frame in proximity to said cam-wheel, an oscillating block in said frame for movement toward said cam working face, a lock-block for imparting movement to said oscillating block, a regulating-wedge having engagement with said lock-block, and a spring-controlled operating-wedge for moving said regulating-wedge, substantially as set forth.
16. In a clutch, the combination of a cam-wheel, having an undulatory working face, a frame in proximity with said cam-wheel, an oscillating block in said frame for movement toward the working face of said cam, a lock-block for imparting movement to said oscillating block, a regulating-wedge engaging said lock-block, and an operating-wedge engaging said regulating-wedge, substantially as set forth.
17. In a clutch, the combination of a cam-wheel having an undulatory working face, a frame in proximity with said cam-wheel, an oscillating block in said frame for movement toward the working face of said cam, a lock-block for imparting movement to said oscillating block, a regulating-wedge engaging said lock-block, and a spring-controlled operating-wedge engaging said regulating-wedge, substantially as set forth.
18. In a clutch, the combination of a cam-wheel having an undulatory working face, a frame in proximity to said cam-wheel, an oscillating block in said frame, an antifriction-roller interposed between said oscillating block and cam working face, a spring bearing against said oscillating block, a lock-block bearing against said spring, a regulating-wedge engaging said lock-block, and an operating-wedge bearing against said regulating-wedge, a shift-collar for actuating said operating-wedge, and a spring mounted between the forward end of said operating-wedge and said shift-collar, substantially as and for the purpose set forth.

wedge engaging said lock-block, and an operating-wedge bearing against said regulating-wedge, substantially as set forth.

19. In a clutch, the combination of a cam-wheel having an undulatory working face, a frame in proximity to said cam-wheel, an oscillating block in said frame, an antifriction-roller interposed between said oscillating block and cam working face, a spring bearing against said oscillating block, a lock-block bearing against said spring, a regulating-wedge engaging said lock-block, an operating-wedge bearing against said regulating-wedge, and a spring associated with said operating-wedge to be compressed during the movement of said operating-wedge and to impart movement to the operating-wedge thereafter, substantially as set forth.

20. In a clutch, the combination of a cam having an undulatory working face, a frame in proximity to said cam-wheel, an oscillating block in said frame, an antifriction-roller interposed between said oscillating block and cam working face, a spring bearing against said oscillating block, a lock-block bearing against said spring, a regulating-wedge engaging said lock-block, an operating-wedge bearing against said regulating-wedge, a shift-collar for actuating said operating-wedge, and a spring mounted between the forward end of said operating-wedge and said shift-collar, substantially as and for the purpose set forth.

LOUIS J. CRECELIUS.

In presence of—

E. S. KNIGHT,

NELLIE V. ALEXANDER.