

(19) World Intellectual Property Organization
International Bureau



(43) International Publication Date
2 February 2006 (02.02.2006)

PCT

(10) International Publication Number
WO 2006/011936 A3

(51) International Patent Classification:
H01L 33/00 (2006.01)

(21) International Application Number:
PCT/US2005/010868

(22) International Filing Date: 30 March 2005 (30.03.2005)

(25) Filing Language: English

(26) Publication Language: English

(30) Priority Data:
10/881,814 30 June 2004 (30.06.2004) US

(71) Applicant (for all designated States except US): CREE, INC. [US/US]; 4600 Silicon Drive, Durham, NC 27703 (US).

(72) Inventors; and

(75) Inventors/Applicants (for US only): HABERERN, Kevin [US/US]; 105 Longbridge Drive, Cary, NC 27511 (US). BERGMANN, Michael, John [US/US]; 5700 Hideaway Drive, Chapel Hill, NC 27516 (US). MIECZKOWSKI, Van [US/US]; 4316 Glen Arbor Drive, Apex, North Carolina 27516 (US). EMERSON, David, Todd [US/US]; 15 Winthorp Court, Durham, NC 27707 (US).

(74) Agent: MYERS BIGEL SIBLEY & SAJOVEC, P.A.; P.O. Box 37428, Raleigh, NC 27627 (US).

(81) Designated States (unless otherwise indicated, for every kind of national protection available): AE, AG, AL, AM, AT, AU, AZ, BA, BB, BG, BR, BW, BY, BZ, CA, CH, CN, CO, CR, CU, CZ, DE, DK, DM, DZ, EC, EE, EG, ES, FI, GB, GD, GE, GH, GM, HR, HU, ID, IL, IN, IS, JP, KE, KG, KP, KR, KZ, LC, LK, LR, LS, LT, LU, LV, MA, MD, MG, MK, MN, MW, MX, MZ, NA, NI, NO, NZ, OM, PG, PH, PL, PT, RO, RU, SC, SD, SE, SG, SK, SL, SM, SY, TJ, TM, TN, TR, TT, TZ, UA, UG, US, UZ, VC, VN, YU, ZA, ZM, ZW.

(84) Designated States (unless otherwise indicated, for every kind of regional protection available): ARIPO (BW, GH, GM, KE, LS, MW, MZ, NA, SD, SL, SZ, TZ, UG, ZM, ZW), Eurasian (AM, AZ, BY, KG, KZ, MD, RU, TJ, TM), European (AT, BE, BG, CH, CY, CZ, DE, DK, EE, ES, FI, FR, GB, GR, HU, IE, IS, IT, LT, LU, MC, NL, PL, PT, RO, SE, SI, SK, TR), OAPI (BF, BJ, CF, CG, CI, CM, GA, GN, GQ, GW, ML, MR, NE, SN, TD, TG).

Published:
— with international search report

(88) Date of publication of the international search report:
7 December 2006

[Continued on next page]

(54) Title: LIGHT EMITTING DEVICES HAVING CURRENT BLOCKING STRUCTURES AND METHODS OF FABRICATING LIGHT EMITTING DEVICES HAVING CURRENT BLOCKING STRUCTURES

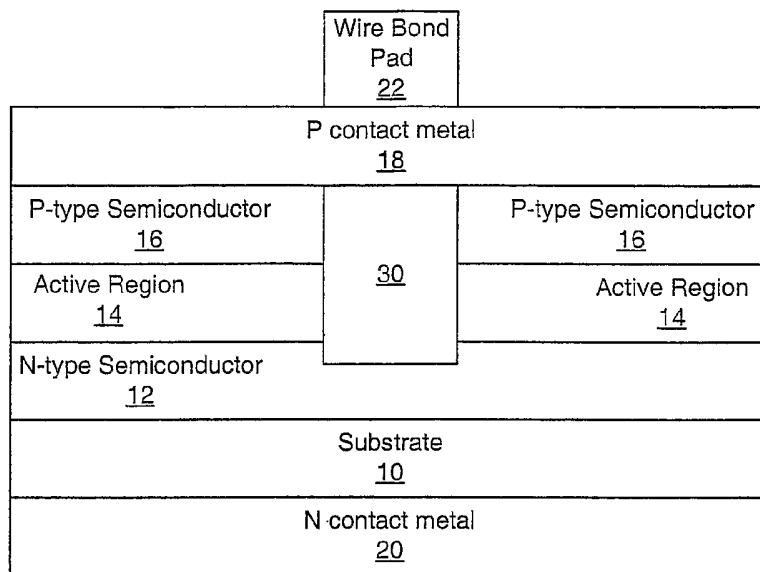

(57) Abstract: Light emitting devices and methods of fabricating light emitting devices having a current blocking mechanism below the wire bond pad (22) are provided. The current blocking mechanism may be a reduced conduction region (30) in an active region (14) of the device. The current blocking mechanism could be a damage region of a layer on which a contact (18) is formed. The current blocking mechanism could be a Schottky contact between an ohmic contact (18) and the active region (14) of the device. A semiconductor junction, such as a PN junction could also be provided between the ohmic contact (18) and the active region (14).

WO 2006/011936 A3



For two-letter codes and other abbreviations, refer to the "Guidance Notes on Codes and Abbreviations" appearing at the beginning of each regular issue of the PCT Gazette.

INTERNATIONAL SEARCH REPORT

International Application No
PCT/US2005/010868

A. CLASSIFICATION OF SUBJECT MATTER
INV. H01L33/00

According to International Patent Classification (IPC) or to both national classification and IPC

B. FIELDS SEARCHED

Minimum documentation searched (classification system followed by classification symbols)
H01L H01S

Documentation searched other than minimum documentation to the extent that such documents are included in the fields searched

Electronic data base consulted during the international search (name of data base and, where practical, search terms used)

EPO-Internal, WPI Data, PAJ, INSPEC, COMPENDEX

C. DOCUMENTS CONSIDERED TO BE RELEVANT

Category *	Citation of document, with indication, where appropriate, of the relevant passages	Relevant to claim No.
X	LEE Y H ET AL: "CHARACTERISTICS OF TOP-SURFACE-EMITTING GAAS QUANTUM-WELL LASERS" IEEE PHOTONICS TECHNOLOGY LETTERS, IEEE SERVICE CENTER, PISCATAWAY, NJ, US, vol. 2, no. 9, 1 September 1990 (1990-09-01), pages 686-688, XP000170554 ISSN: 1041-1135 page 686, left-hand column, paragraph 2 - page 686, right-hand column, paragraph 2 figure 2 ----- -/--	1-6, 8-12, 31-36, 38-41

Further documents are listed in the continuation of box C.

Patent family members are listed in annex.

* Special categories of cited documents:

- *A* document defining the general state of the art which is not considered to be of particular relevance
- *E* earlier document but published on or after the international filing date
- *L* document which may throw doubts on priority claim(s) or which is cited to establish the publication date of another citation or other special reason (as specified)
- *O* document referring to an oral disclosure, use, exhibition or other means
- *P* document published prior to the international filing date but later than the priority date claimed

- *T* later document published after the international filing date or priority date and not in conflict with the application but cited to understand the principle or theory underlying the invention
- *X* document of particular relevance; the claimed invention cannot be considered novel or cannot be considered to involve an inventive step when the document is taken alone
- *Y* document of particular relevance; the claimed invention cannot be considered to involve an inventive step when the document is combined with one or more other such documents, such combination being obvious to a person skilled in the art.
- *Z* document member of the same patent family

Date of the actual completion of the international search

Date of mailing of the international search report

3 August 2006

17/08/2006

Name and mailing address of the ISA
European Patent Office, P.B. 5818 Patentlaan 2
NL - 2280 HV Rijswijk
Tel. (+31-70) 340-2040, Tx. 31 651 epo nl,
Fax: (+31-70) 340-3016

Authorized officer

Sauerer, C

INTERNATIONAL SEARCH REPORT

International Application No
PCT/US2005/010868

C.(Continuation) DOCUMENTS CONSIDERED TO BE RELEVANT

Category *	Citation of document, with indication, where appropriate, of the relevant passages	Relevant to claim No.
X	WO 03/061021 A (REGENTS OF THE UNIVERSITY OF CALIFORNIA, THE OFFICE OF TECHNOLOGY TRAN) 24 July 2003 (2003-07-24) page 7, paragraph 35 - page 14, paragraph 72 figures 3,11A-11D	1-3,7,8, 10-12, 31-33, 37,38, 40,41
X	US 2004/066820 A1 (JOHNSON RALPH H ET AL) 8 April 2004 (2004-04-08) figure 1 page 3, paragraph 24 - page 4, paragraph 29	1-6, 10-12, 31-36,40
X	WO 03/058772 A (HONEYWELL INTERNATIONAL INC) 17 July 2003 (2003-07-17) page 6, line 25 - page 8, line 23 figure 2	1-6, 10-12, 31-36, 40,41
X	HOI-JUN YOO ET AL: "FABRICATION OF VERTICAL-CAVITY FRONT-SURFACE-EMITTING LASER DIODE (FSELD) USING A HETEROJUNCTION BIPOLAR TRANSISTOR PROCESS" JAPANESE JOURNAL OF APPLIED PHYSICS, JAPAN SOCIETY OF APPLIED PHYSICS, TOKYO, JP, vol. 30, no. 3B, 15 March 1991 (1991-03-15), pages L492-L494, XP000224873 ISSN: 0021-4922 paragraph [0002]; figures 1-3	1-6, 8-12, 31-36, 38-41
X	US 5 245 622 A (JEWELL ET AL) 14 September 1993 (1993-09-14) figures 1-3,9 column 4, line 60 - column 6, line 54 column 8, line 55 - column 9, line 24	1,5, 10-12, 31,35
X	PATENT ABSTRACTS OF JAPAN vol. 2003, no. 12, 5 December 2003 (2003-12-05) -& JP 2004 172189 A (SAKAI SHIRO; NITRIDE SEMICONDUCTOR CO LTD), 17 June 2004 (2004-06-17) abstract; figures 1,3,8	13,14, 16, 19-21, 42,43, 45,48
	-/--	

INTERNATIONAL SEARCH REPORT

 International Application No
 PCT/US2005/010868

C.(Continuation) DOCUMENTS CONSIDERED TO BE RELEVANT		
Category *	Citation of document, with indication, where appropriate, of the relevant passages	Relevant to claim No.
X	PATENT ABSTRACTS OF JAPAN vol. 2003, no. 05, 12 May 2003 (2003-05-12) -& JP 2003 017748 A (SEIWA ELECTRIC MFG CO LTD), 17 January 2003 (2003-01-17) abstract; figures 1,2	13, 19-22, 42,48
X	US 6 258 614 B1 (KANEKO YAWARA) 10 July 2001 (2001-07-10) figures 2A-6D column 1, line 45 - column 2, line 16 column 5, line 31 - column 8, line 14	13-22, 42-48
X	EP 0 929 109 A (PIONEER ELECTRONIC CORPORATION) 14 July 1999 (1999-07-14) column 1, line 42 - line 58 column 4, line 12 - column 5, line 30 figures 2a-3b	13,14, 17,42, 43,46
X	EP 0 911 887 A (MATSUSHITA ELECTRIC INDUSTRIAL CO., LTD) 28 April 1999 (1999-04-28) column 13, line 46 - column 14, line 51 figure 2	23-25, 49-51
X	DE 198 17 368 A1 (EPISTAR CORP., HSINCHU, TEI PAI, TW) 24 December 1998 (1998-12-24) column 2, line 54 - line 66 column 4, line 17 - column 6, line 4 figures 4-5B	23-25, 49-51
X	PATENT ABSTRACTS OF JAPAN vol. 2000, no. 20, 10 July 2001 (2001-07-10) -& JP 2001 077414 A (SHOWA DENKO KK), 23 March 2001 (2001-03-23) abstract; figure 1	26,27, 29,30, 52,53, 55,56
X	PATENT ABSTRACTS OF JAPAN vol. 1999, no. 12, 29 October 1999 (1999-10-29) -& JP 11 186607 A (SHOWA DENKO KK), 9 July 1999 (1999-07-09) abstract; figure 4	26, 28-30, 52,54-56

INTERNATIONAL SEARCH REPORT

International application No.
PCT/US2005/010868

Box II Observations where certain claims were found unsearchable (Continuation of item 2 of first sheet)

This International Search Report has not been established in respect of certain claims under Article 17(2)(a) for the following reasons:

1. Claims Nos.:
because they relate to subject matter not required to be searched by this Authority, namely:

2. Claims Nos.:
because they relate to parts of the International Application that do not comply with the prescribed requirements to such an extent that no meaningful International Search can be carried out, specifically:

3. Claims Nos.:
because they are dependent claims and are not drafted in accordance with the second and third sentences of Rule 6.4(a).

Box III Observations where unity of invention is lacking (Continuation of item 3 of first sheet)

This International Searching Authority found multiple inventions in this international application, as follows:

see additional sheet

1. As all required additional search fees were timely paid by the applicant, this International Search Report covers all searchable claims.

2. As all searchable claims could be searched without effort justifying an additional fee, this Authority did not invite payment of any additional fee.

3. As only some of the required additional search fees were timely paid by the applicant, this International Search Report covers only those claims for which fees were paid, specifically claims Nos.:

4. No required additional search fees were timely paid by the applicant. Consequently, this International Search Report is restricted to the invention first mentioned in the claims; it is covered by claims Nos.:

Remark on Protest

The additional search fees were accompanied by the applicant's protest.

No protest accompanied the payment of additional search fees.

FURTHER INFORMATION CONTINUED FROM PCT/ISA/ 210

This International Searching Authority found multiple (groups of) inventions in this international application, as follows:

1. claims: 1-22,31-48

A light emitting device, comprising:
an active region of semiconductor material;
a first contact on the active region, the first contact having a portion corresponding to a bond pad region of the first contact; a current confinement structure; and
a second contact electrically coupled to the active region; and a method of fabricating said light emitting device.

2. claims: 23-25,49-51

A light emitting device, comprising:
an active region of semiconductor material;
a Schottky contact on the active region;
a first ohmic contact on the active region and the Schottky contact, a portion of the first ohmic contact on the Schottky contact corresponding to a bond pad region of the first ohmic contact; and
a second ohmic contact electrically coupled to the active region; and
a method of fabricating said light emitting device.

3. claims: 26-30,52-56

A light emitting device, comprising:
an active region of semiconductor material;
a first ohmic contact on the active region, a portion of the first ohmic contact directly on a region of semiconductor material of a first conductivity type and a second portion of the first ohmic contact directly on a region of semiconductor material of a second conductivity type opposite the first conductivity type, the second portion corresponding to a bond pad region of the first ohmic contact; and
a second ohmic contact electrically coupled to the active region; and
a method of fabricating said light emitting device.

INTERNATIONAL SEARCH REPORT

Information on patent family members

International Application No

PCT/US2005/010868

Patent document cited in search report		Publication date	Patent family member(s)	Publication date
WO 03061021	A	24-07-2003	AU 2002359779 A1	30-07-2003
US 2004066820	A1	08-04-2004	CA 2430348 A1 EP 1354376 A2 JP 2004529487 T TW 512562 B WO 0245217 A2 US 2004066819 A1 US 6905900 B1 US 2004213311 A1	06-06-2002 22-10-2003 24-09-2004 01-12-2002 06-06-2002 08-04-2004 14-06-2005 28-10-2004
WO 03058772	A	17-07-2003	TW 236198 B US 2003123512 A1	11-07-2005 03-07-2003
US 5245622	A	14-09-1993	AU 4236993 A CA 2135182 A1 CN 1081541 A DE 69323433 D1 DE 69323433 T2 EP 0663112 A1 JP 7507183 T WO 9322813 A1	29-11-1993 11-11-1993 02-02-1994 18-03-1999 02-09-1999 19-07-1995 03-08-1995 11-11-1993
JP 2004172189	A	17-06-2004	NONE	
JP 2003017748	A	17-01-2003	NONE	
US 6258614	B1	10-07-2001	NONE	
EP 0929109	A	14-07-1999	DE 69922061 D1 DE 69922061 T2 JP 11204833 A US 6200827 B1	30-12-2004 24-11-2005 30-07-1999 13-03-2001
EP 0911887	A	28-04-1999	CN 1215931 A JP 11135834 A TW 419871 B US 6169296 B1	05-05-1999 21-05-1999 21-01-2001 02-01-2001
DE 19817368	A1	24-12-1998	JP 3084364 B2 JP 11017220 A US 6057562 A	04-09-2000 22-01-1999 02-05-2000
JP 2001077414	A	23-03-2001	NONE	
JP 11186607	A	09-07-1999	JP 3516434 B2	05-04-2004