



- (51) International Patent Classification:
A61B 5/00 (2006.01)
- (21) International Application Number:
PCT/US2015/016838
- (22) International Filing Date:
20 February 2015 (20.02.2015)
- (25) Filing Language: English
- (26) Publication Language: English
- (30) Priority Data:
61/943,684 24 February 2014 (24.02.2014) US
61/948,973 6 March 2014 (06.03.2014) US
- (71) Applicant: **MEDTRONIC MONITORING, INC.**
[US/US]; 2033 Gateway Place, Suite 100, San Jose, California 95110-9300 (US).
- (72) Inventors: **LAI, Arthur**; 6187 Sunny Road, Minnetonka, Minnesota 55345 (US). **ENGEL, Jonathan**; 221 Washburn Avenue North, Minneapolis, Minnesota 55405 (US). **SWAMINATHAN, Senthil**; 142 West Douglas Street, St. Paul, Minnesota 55075 (US). **PIAGET, Thomas**; 1915 Jefferson Avenue, St. Paul, Minnesota 55105 (US). **LANDRUM, Brett A.**; 5765 Oxford Street North, Shoreview, Minnesota 55126 (US). **WILLIAMS, Scott**; 3604 17th Avenue, Minneapolis, Minnesota 55407 (US).

CHAVAN, Abhi; 6491 Ranchview Lane, Maple Grove, Minnesota 55311 (US).

(74) Agents: **COLLINS, Michael A.** et al.; Billion & Armitage, 7401 Metro Blvd., Suite 425, Minneapolis, Minnesota 55439 (US).

(81) Designated States (unless otherwise indicated, for every kind of national protection available): AE, AG, AL, AM, AO, AT, AU, AZ, BA, BB, BG, BH, BN, BR, BW, BY, BZ, CA, CH, CL, CN, CO, CR, CU, CZ, DE, DK, DM, DO, DZ, EC, EE, EG, ES, FI, GB, GD, GE, GH, GM, GT, HN, HR, HU, ID, IL, IN, IR, IS, JP, KE, KG, KN, KP, KR, KZ, LA, LC, LK, LR, LS, LU, LY, MA, MD, ME, MG, MK, MN, MW, MX, MY, MZ, NA, NG, NI, NO, NZ, OM, PA, PE, PG, PH, PL, PT, QA, RO, RS, RU, RW, SA, SC, SD, SE, SG, SK, SL, SM, ST, SV, SY, TH, TJ, TM, TN, TR, TT, TZ, UA, UG, US, UZ, VC, VN, ZA, ZM, ZW.

(84) Designated States (unless otherwise indicated, for every kind of regional protection available): ARIPO (BW, GH, GM, KE, LR, LS, MW, MZ, NA, RW, SD, SL, ST, SZ, TZ, UG, ZM, ZW), Eurasian (AM, AZ, BY, KG, KZ, RU, TJ, TM), European (AL, AT, BE, BG, CH, CY, CZ, DE, DK, EE, ES, FI, FR, GB, GR, HR, HU, IE, IS, IT, LT, LU, LV, MC, MK, MT, NL, NO, PL, PT, RO, RS, SE, SI, SK, SM, TR), OAPI (BF, BJ, CF, CG, CI, CM, GA, GN, GQ, GW, KM, ML, MR, NE, SN, TD, TG).

[Continued on next page]

(54) Title: SEPARABLE MONITORING DEVICE AND METHOD

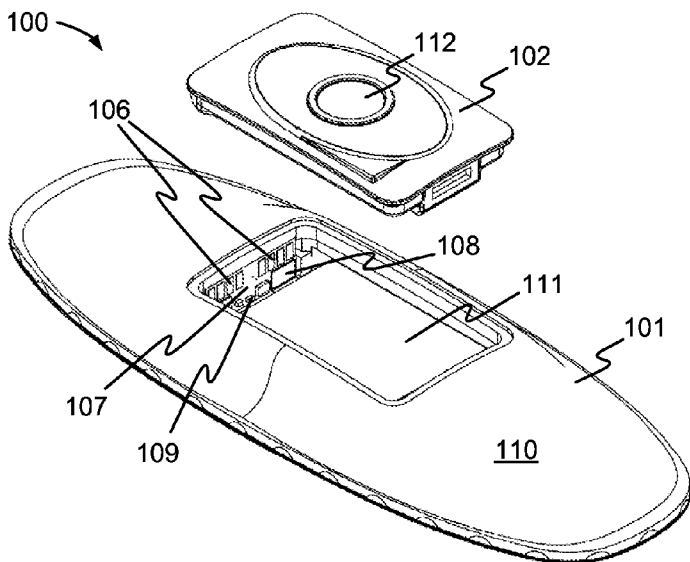

FIG. 1A

(57) Abstract: A patient monitoring device includes reusable and disposable portions. The disposable portion includes two or more electrodes for coupling to the skin of the patient, a battery, and a first set of electrical contacts. The reusable portion includes a processor, memory, a second set of electrical contacts, and sensing circuitry coupled to the at least two electrodes, wherein the reusable portion is mechanically coupleable to the disposable portion and wherein the reusable portion is electrically coupleable to the disposable portion through the first and second electrical contacts. The sensing circuitry and the processor are powered from the battery through the coupled first and second electrical contacts, and wherein when the reusable portion and the disposable portion are mechanically uncoupled after having been mechanically coupled, the disposable portion is rendered unusable by the process of mechanically uncoupling the reusable portion and the disposable portion.



Declarations under Rule 4.17:

— *as to the applicant's entitlement to claim the priority of the earlier application (Rule 4.17(iii))*

Published:

— *with international search report (Art. 21(3))*

SEPARABLE MONITORING DEVICE AND METHOD

CROSS-REFERENCE TO RELATED APPLICATIONS

[0001] The present invention claims priority to U.S. Provisional Patent Application No. 61/943,684, titled “Physiological Monitoring Device and Method”, filed February 24, 2014 and U.S. Provisional Patent Application No. 61/948,973, titled “Separable Monitoring Device and Method”, filed March 6, 2014, both of which are incorporated by reference in their entirety. A claim of priority is made.

BACKGROUND OF THE INVENTION

[0002] Various devices have been developed for monitoring physiological parameters of a patient, for the detection, diagnosis, or prediction of health problems. For example, U.S. Patent Application Publications 2009/0076344 and 2009/0076345 describe adherent patches that monitor patient parameters such as tissue impedance, electrocardiogram signals, and other parameters, and transmit information wirelessly to a central server.

[0003] It is desirable that the cost of monitoring devices and services be kept low.

BRIEF SUMMARY OF THE INVENTION

[0004] In one aspect, a monitoring device for monitoring one or more physiological parameters of a patient comprises a disposable portion comprising at least two electrodes for coupling to the skin of the patient, a battery, and a first set of electrical contacts. The monitoring device further comprises a reusable portion comprising a processor, memory, a second set of electrical contacts, and sensing circuitry coupled to the at least two electrodes. The reusable portion is mechanically coupleable to the disposable portion and the reusable portion is electrically coupleable to the disposable portion through the first and second electrical contacts. When the reusable portion and the disposable portion are electrically coupled through the first and second electrical contacts, signals from the at least two electrodes are passed to the sensing circuitry and processed by the processor. The sensing circuitry and the processor are powered from the battery through the coupled first and second electrical contacts, and when the reusable portion and the disposable portion are mechanically uncoupled after having been mechanically coupled, the disposable portion is rendered

unusable by the process of mechanically uncoupling the reusable portion and the disposable portion.

[0005] In another aspect, a monitoring device for monitoring one or more physiological parameters of a patient includes a disposable portion and a reusable portion. The disposable portion comprises at least two electrodes for coupling to the skin of the patient, a battery, and a first set of electrical contacts. The reusable portion comprises a processor, memory, a second set of electrical contacts, and sensing circuitry coupled to the at least two electrodes, wherein the reusable portion is mechanically coupleable to the disposable portion such that when the reusable portion and the disposable portion are mechanically coupled they form a water-resistant unit, and wherein the reusable portion is electrically coupleable to the disposable portion through the first and second electrical contacts. In addition, when the reusable portion and the disposable portion are electrically coupled through the first and second electrical contacts, signals from the at least two electrodes are passed to the sensing circuitry and processed by the processor, and wherein the sensing circuitry and the processor are powered from the battery through the coupled first and second electrical contacts. In addition, the reusable portion and the disposable portion are separable, and wherein the reusable portion can be used with a different disposable portion.

[0006] A monitoring device for monitoring an electrocardiogram of the patient includes a disposable portion and a reusable portion. The disposable portion includes a shell having a bay and a first surface for adhering to the skin of a patient. The disposable portion includes at least two skin electrodes on the first surface of the shell, a battery housed within the shell, and a first set of electrical contacts within the bay and in electrical communication with the battery and the skin electrodes. The reusable portion is releasably received and mechanically coupled within the bay of the disposable portion. The reusable portion comprises a monitoring circuit and a second set of electrical contacts in electrical communication with the monitoring circuit. The bay of the disposable portion and the reusable portion include interlocking features that releasably lock the reusable portion in the bay of the disposable portion with the second set of electrical contacts in electrical contact with the first set of electrical contacts such that the skin electrodes and battery of the disposable portion are in electrical communication with the monitoring circuit of the reusable portion. The bay includes first and second ends, the first set of electrical contacts being arranged along the first end, the interlocking features including a breakable feature arranged along the second end.

BRIEF DESCRIPTION OF THE DRAWINGS

[0007] FIG. 1A illustrates an exploded view of a monitoring device in accordance with embodiments of the invention.

[0008] FIG. 1B shows a reverse angle view of a disposable portion of the monitoring device of FIG. 1A.

[0009] FIGS. 2A and 2B illustrate the process of mechanically coupling a reusable portion and a disposable portion of the monitoring device of FIGS. 1A and 1B.

[0010] FIG. 3 illustrates a conceptual schematic view of an electronic architecture of the monitoring device of FIGS. 1A and 1B, in accordance with embodiments of the invention.

[0011] FIG. 4 illustrates the monitoring device of FIGS. 1A and 1B adhered to a patient.

[0012] FIG. 5 illustrates the construction of an embodiment of a disposable portion in more detail.

[0013] FIG. 6 illustrates an underside view of a foam cover, in accordance with embodiments.

[0014] FIG. 7 illustrates a technique for rendering the disposable portion of the device of FIGS. 1A and 1B unusable, according to embodiments.

[0015] FIGS. 8A and 8B show additional details of the technique of FIG. 7.

DETAILED DESCRIPTION OF THE INVENTION

[0016] **FIG. 1A** illustrates an exploded view of a monitoring device **100** in accordance with embodiments of the invention. Monitoring device **100** is capable of monitoring one or more physiological parameters of a patient. Device **100** includes a disposable portion **101** and a reusable portion **102**.

[0017] **FIG. 1B** shows a reverse angle view of disposable portion **101**. Disposable portion **101** includes a number of electrodes **103a-103d**. While four electrodes are shown in this example, different numbers of electrodes may be provided, depending on the physiological parameter or parameters a particular device is intended to monitor. Electrodes **103a-103d** are configured to couple to the skin of the patient. For example, device **100** may be adhered to the thorax of the patient using an adhesive layer on the bottom side of bottom layer **104**. Device **100** may be initially supplied with a release layer (not shown) that protects the adhesive and electrodes during shipping and storage, and that is removed before adhering the device to the patient. In some embodiments, electrodes **103a-103d** are overlaid by a gels held in pockets **105a-105d** formed between bottom layer **104** and another internal layer. The

gels may enhance electrical contact between electrodes **103a-103d** and the patient's skin. Additional details of possible arrangements of electrodes, gels, and structural layers usable in embodiments of the invention may be found in US Patent Application Publication 2011/0144470 published June 16, 2011 and titled "Body Adherent Patch with Electronics for Physiologic Monitoring", the entire disclosure of which is incorporated by reference herein for all purposes.

[0018] Each of electrodes **103a-103d** is electrically connected to one of a first set of electrical contacts **106**. For example, electrodes **103a-103d** may be formed on a flexible circuit that includes electrical traces that connect electrodes **103a-103d** to electrical contacts **106**. Electrical contacts **106** may be formed on a printed circuit board **107** that also includes a connector **108** for receiving a flex circuit or other connection to electrodes **103a-103d**. Some electronic components **109** may also be provided on printed circuit board **107**. Disposable portion **101** also includes a battery (not visible in Figs. 1A and 1B).

[0019] The outer portion of disposable portion **101** may be covered with a flexible, breathable material **110** that is waterproof or water resistant, and is sealed around the edges directly or indirectly to bottom layer **104**, so that device **100** can withstand being splashed with water without compromising the usability of the device. For example, material **110** may be a cloth including polyester, polyamide, nylon, and/or elastane (Spandex™). The breathable fabric may be coated or otherwise configured to make it water resistant or waterproof. In other embodiments, the outer portion of disposable portion **101** may be made of a non-breathable material, and moisture egress from the patient's skin may be provided by openings within the material.

[0020] Reusable portion **102** contains electronic components as described in more detail below. Reusable portion **102** includes a second set of electrical contacts (not visible in Figs. 1A and 1B) that are complementary to first electrical contacts **106**, so that signals from electrodes **103a-103d** are coupled to reusable portion **102** when the two sets of contacts are engaged. Power from the battery in disposable portion **101** is also transferred through electrical contacts **106**, to power reusable portion **102**.

[0021] In this example, reusable portion **102** snaps securely into a frame formed around pocket (or bay) **111**. Preferably, reusable portion **102** is a sealed module that can also withstand being splashed with water. Preferably, when disposable portion **101** and reusable portion **102** are mechanically coupled together, they form a water resistant unit. For example, reusable portion **102** may fit snugly enough into pocket **111** to substantially prevent

the ingress of splashed water into pocket **111**, or may be sealed using a gasket or the like. Preferably, the adhesive on bottom side **104** is also water resistant and has a high moisture vapor transmission rate, so that device **100** can be worn for extended periods while allowing the user to participate in normal daily activities, including showering. For example, in some embodiments, bottom layer **104** may be made of MED 5021 polyurethane film available from Avery Dennison Corporation of Pasadena, Calif., USA, or Tegaderm™ film available from the 3M Company of St. Paul Minn., USA, or a similar material. The material of bottom layer **104** may have a moisture vapor transmission rate of at least 100 g/m²/24hrs, at least 400 g/m²/24hrs, or another suitable value. In some embodiments, device **100** can be worn for up to 180 hours or more without being removed from the patient.

[0022] Button **112** may be actuated by the patient as is explained in more detail below.

[0023] FIGS. 2A and 2B illustrate the process of mechanically coupling reusable portion **102** with disposable portion **101**. In FIG. 2A, reusable portion **102** has been positioned to hook the far edge of reusable portion **102** (not visible in FIG. 2A) with the far edge of pocket **111**. A snap feature **201** is configured to engage with a complementary feature (not visible) on the near edge of pocket **111**. Reusable portion **102** is then rotated downward to engage snap feature **201**, so that device **100** is assembled into the configuration shown in FIG. 2B. Preferably, device **100** is not disassemblable by the user to separate reusable portion **102** from disposable portion **101**.

[0024] FIG. 3 illustrates a conceptual schematic view of an electronic architecture of monitoring device **100**, in accordance with embodiments of the invention. Disposable portion **101** includes electrodes **103a-103d**, and a primary battery **301**. Primary battery **301** preferably has sufficient energy storage capacity to power monitoring device **100**, including reusable portion **102**, for a complete monitoring period, for example up to 180 hours or more. Electrodes **103a-103d** and the terminals of battery **301** are connected through electrical contacts **302** to reusable portion **102**. Electrical contacts **302** include first electrical contacts **106** on disposable portion **101**, as well as second electrical contacts **316** on reusable portion **102**. Electrical contacts **302** are engaged when disposable portion **101** and reusable portion **102** are assembled to each other.

[0025] Disposable portion **101** also includes a disposable portion identifier **303**, which is also communicated to reusable portion **102** through electrical contacts **302**. The depiction of disposable portion identifier **303** and its connection to reusable portion **102** in FIG. 3 is conceptual, and this functionality may be implemented using any suitable technique or

combination of techniques. For example, disposable portion identifier may be stored in a memory addressable through electrical contacts **302**, may be configured using a set of switches or fusible links that can be sensed through electrical contacts **302**, may be repeatedly serially transmitted on a signal line, or may be implemented in some other way. The storage and transmission of disposable portion identifier **303** may be passive (not requiring any power) or may require electrical power, in which case power is supplied from primary battery **301**, from the signal lines of processor **307** described below, or from another source. Power distribution lines are not depicted in FIG. 3 so as not to obscure the operation of the device in unnecessary detail. Similarly, certain connections between components are simplified. For example, certain connections that involve multiple signal paths or a combination of power and signal paths may be shown using a single line. In other cases, amplification or buffering circuitry and the like may not be shown.

[0026] Reusable portion **102** comprises a secondary battery **304** and a real time clock **305** powered by secondary battery **304**. Secondary battery **304** may be, for example, a rechargeable lithium ion battery or another suitable kind of battery. Real time clock **305** enables reusable portion **102** to maintain an accurate time, even when reusable portion **102** is not connected to any disposable portion **101**, and does not receive power from primary battery **301**. Because secondary battery **304** need only power real time clock **305**, it may have a smaller energy storage capacity than primary battery **301**. Reusable portion **102** also comprises charging circuit **306**, for charging secondary battery **304** using energy from primary battery **301**, when available.

[0027] In other embodiments, a single battery may be used, residing in reusable portion **102**. The single battery may have enough capacity to power monitoring device **100** for up to 180 hours or more, and may be rechargeable through electrical contacts such as contacts **316** on reusable portion **102**. The single battery may also be able to power real time clock **305** for longer periods. Any necessary power for components in disposable portion **101** may be transferred through the contacts. The single battery may be recharged at any suitable time, for example before reusable portion **102** is installed in a new disposable portion **101**, or when data is read from reusable portion **102** at the end of a monitoring period as is described in more detail below. In other embodiments, the single battery may be replaceable, and may be replaced each time reusable portion **102** is assembled into a new disposable portion **101**. The replaced battery may preferably be rechargeable off line.

[0028] Referring again to FIG. 3, reusable portion **102** also includes a processor **307** for controlling the operation of monitoring device **100**, analyzing signals, and communicating with other devices. Processor **307** may be, for example, a microprocessor as depicted in FIG. 3, or may be a microcontroller, digital signal processor, programmed gate array, or another kind of circuitry that can perform the necessary functions.

[0029] Signals from electrodes **103a-103d** are coupled to processor **307** through contacts **302**. The coupling may be direct, or additional circuitry may be present between electrodes **103a-103d** and processor **307**, for example signal conditioning circuitry, drive circuitry, switching circuitry, and the like. In FIG. 3, such circuitry is depicted as conditioning/drive circuitry **308**. Conditioning/drive circuitry **308** may include, for example, signal conditioning amplifiers, noise filters, or the like.

[0030] In some embodiments, individual ones of electrodes **103a-103d** may perform different functions at different times. For example, at one time, processor **307** may configure monitoring device **100** to measure an electrocardiogram (ECG) of the patient using two or three of the electrodes, and at another time, processor **307** may configure monitoring device **100** to measure a tissue impedance of the patient by driving a known alternating current between electrodes **103b** and **103c**, and measuring the voltage impressed between electrodes **103a** and **103d**. In order that electrodes **103a-103d** can perform multiple functions, switching circuitry may be provided that switches electrodes between driving and sensing modes, for example. Additional details of such switching circuitry may be found in U.S. Patent Application Publication No. 2009/0076345 published March 19, 2009 and titled "Adherent Device with Multiple Physiological Sensors", the entire disclosure of which is incorporated by reference herein for all purposes.

[0031] Reusable portion **102** further includes memory **309** accessible by processor **307**. While only a single block is shown in FIG. 3, it will be understood that memory **309** may comprise one or more kinds of memory, including one or more of random access memory (RAM), read only memory (ROM), flash memory, electrically erasable programmable read only memory (EEPROM), or other kinds of memory. Memory **309** may hold instructions for processor **307**, such that the functions of monitoring device **100** are caused to be carried out when processor **307** executes the instructions. Memory **309** preferably also stores a unique reusable portion identifier. In addition, data monitored from electrodes **103a-103d** may be stored in memory **309**, as is described in more detail below.

[0032] Reusable portion **102** further includes wireless communication circuitry **310** and an antenna **311**, for wirelessly transmitting and receiving information to and from one or more external devices. For example, wireless communication circuitry **310** may implement a protocol such as Bluetooth[®], ZigBee[®], Wi-Fi[®], or another kind of standard or proprietary protocol.

[0033] Button **112** enables a user of monitoring device **100** to signal processor **307**. A connector **312** may be provided for communicating with an external device via a cable or other wired connection. Connector **312** may be, for example, part of a Universal Serial Bus (USB) interface, or another kind of standard or proprietary interface. In some embodiments, an accelerometer **313** enables measurement of the patient's orientation and activity level.

[0034] One or more light sources **314** may be provided for indicating the state of monitoring device **100** or for communicating other information. For example, light source **314** may be a light emitting diode that is under control of processor **307**. Light source **314** may produce light of a single color, or may be multi-colored. Information may be communicated using light source **314** by using a particular color, flashing pattern, or both. For example, normal operation may be indicated by a periodic flash of green light from light source **314**, and an error condition may be indicated by emitting steady red light. Many other techniques are possible for communicating information. In some embodiments, more than one light source **314** may be provided, and information may be communicated by either or both of the light sources **314**.

[0035] The brightness of light source **314** may also be controllable, for example by changing the duty cycle of a pulse width modulated (PWM) driving circuit. In some embodiments, monitoring device **100** includes an ambient light sensor **317**, and adjusts the brightness of light source **314**. For example, during the day in a brightly lit room, light source **314** may be illuminated brightly, for good visibility. However, at night, in a dimly lit bedroom or darkened hospital ward, the full brightness of light source **314** may be distracting, while even a dim light may be readily visible. In that case, the brightness of light source **314** may be reduced accordingly, to reduce the distraction caused by light source **314**.

[0036] In some embodiments, monitoring device **100** may include a sound generator **315**, for signaling the patient. Sound generator **315** may be activated to notify the user of a condition that may compromise the operation of monitoring device **100** or for other uses. For example, a signal may be activated to notify the patient that electrical conductivity to the patient's skin has been lost, that wireless connectivity to intermediate device **403** has been

lost, or that some other urgent condition exists. The nature of the condition may be indicated by one or more of the pitch, loudness, or beeping pattern of sound generator **315**, or by some other aspect of the generated sound.

[0037] Due to variations in hearing ability between patients, some patients may be able to hear frequencies that other patients may not, and vice versa. In order to improve the chance that a particular patient will be able to hear sound generator **315**, sound generator **315** may be controlled to produce sounds containing multiple or different frequencies. In one embodiment, sound generator **315** is driven at 850 Hz and then at 950 Hz. In other embodiments, multiple frequencies may be generated simultaneously.

[0038] In some embodiments, monitoring device **100** may include a humidity sensor **317**, configured to detect the ingress of water into reusable portion **102**. For example, humidity sensor **317** may be a resistive or capacitive humidity sensor. Humidity sensor **317** is preferably coupled to processor **307**, which can monitor the output of humidity sensor **317** to detect a threshold level of moisture or a change in moisture inside reusable portion **102** that might indicate ingress of moisture into reusable portion **102**. When moisture ingress is detected, processor may signal the user using light source **314** or sound generator **315**, may transmit an indication of the detection to a remote server using wireless communication circuitry **310**, or may take another action.

[0039] Preferably, before use of a particular monitoring device **100**, the unique identifiers of disposable portion **101** and reusable portion **102** are recorded and matched in a database, to indicate that the two portions are authorized for use together. This pairing may be done before shipment of the device to a particular patient. As is explained in more detail below, reusable portion **102** may be used serially with a number of disposable portions **101**. In this case, a pre-packaged set of one reusable portion **102** and a number of disposable portions **101** may be shipped together, and their unique identifiers may be recorded as a set in the database.

[0040] When disposable portion **101** and reusable portion **102** are assembled together, processor **307** may request the unique identifier of disposable portion **101**. If no unique identifier is received, it may be assumed that a malfunction has occurred, or that the disposable portion may be counterfeit and not trustworthy, or that some other circumstance has occurred that may prevent reliable monitoring. If no identifier is received from disposable portion **101**, processor **307** may simply refuse to proceed with monitoring.

[0041] In other embodiments, reusable portion **102** may be loaded at the time of shipment with the unique identifiers of all disposable portions **101** with which reusable portion **102** is

intended to be used. On power up, reusable portion **102** may read the unique identifier of the particular disposable portion **101** into which it has been assembled, and compare the identifier with its stored list of acceptable identifiers. If the identifier is not found, reusable portion **102** may simply not initiate monitoring. If the identifier is found in the list, then monitoring begins as normal.

[0042] In other embodiments, reusable portion **102** may retrieve unique identifier **303** of disposable portion **101** and report it, along with the unique identifier of reusable portion **102**, to remote server **402** for determination whether the two portions are intended to be used together. If records indicate that the two portions are not intended for use together, remote server **402** may alert monitoring personnel. Even when a mismatch is detected, monitoring device **100** may commence monitoring, including the storing of sampled data and the transmission of event reports, and remote server **402** may accept the transmitted data. However, the fact that an unexpected disposable portion **101** is detected may indicate the possibility of product misuse or unreliable monitoring, which can then be investigated

[0043] Assuming that monitoring is to proceed, monitoring device **100** is adhered to a patient **401**, for example as shown in **FIG. 4**. In some uses, disposable portion **101** may be adhered to patient **401** and then reusable portion **102** assembled into it, and in other uses, monitoring device **100** may be assembled before being adhered to patient **401**.

[0044] Under control of processor **307**, monitoring device **100** may monitor one or more different physiological parameters of patient **401**. For example, an electrocardiogram (ECG) of patient **401** may be recorded from signals sampled from two or more of electrodes **103a-103d**. In some embodiments, the ECG is taken by sampling the voltage between two of electrodes **103a-103d** with a frequency rapid enough to detect the subtle electrical signals produced by the heart of patient **401**. For example, the voltage may be sampled with a frequency of 50 – 1000 Hz. In one embodiment, the voltage is sampled with a frequency of 200 Hz (once every 5 milliseconds). The voltage may be sampled using an analog-to-digital converter (ADC), for example an ADC built into or connected to processor **307**.

[0045] The circuitry used to sense signals from electrodes **103a-103d** may be collectively referred to as sensing circuitry. For example, sensing circuitry may include signal conditioning circuitry **308** and processor **307**, as well as various amplifiers, ADCs, and the like. Many different arrangements are possible.

[0046] In some embodiments, the ECG data may be filtered to remove the effects of interference from common noise sources such as the mains power line. For example, a raw

ECG signal may be sampled at a higher frequency than its ultimate recorded sampling frequency, and digitally filtered. In one embodiment, the raw ECG sampling is done at 600 Hz, the raw data are digitally filtered to remove 50Hz or 60Hz power line noise, and the data are downsampled to 200 Hz for recording.

[0047] More information about the recording of an ECG may be found in U.S. Patent Application Publication No. 2013/0274584 published October 17, 2013 and titled “Heuristic Management of Physiological Data”, the entire disclosure of which is incorporated by reference herein for all purposes.

[0048] In some embodiments, the sampled data (e.g. the 200 Hz ECG voltage samples) are stored in a non-volatile portion of memory **309**. Depending on the resolution of the ADC, each sample may require 8-16 bits of storage, such that 180 hours of sampled data can be conveniently stored in available memory sizes. For the purposes of this disclosure, this stored information may be referred to as “complete” data.

[0049] All monitored information may be encrypted and stored in memory **309**, such that the data can be decrypted only using a key or keys. Encryption may be performed using an algorithm such as RSA, DSS, or another kind of algorithm. Thus, should reusable portion **102** be lost after monitoring the condition of a particular patient, it will not be possible for an unauthorized party to reconstruct sensitive medical information about the patient. In addition, any transmissions of data may also be encrypted.

[0050] Another example of a physiological parameter that may be monitored by monitoring device **100** is the patient’s tissue hydration level. Increased fluid retention in the tissues of the body is a symptom of acute cardiac decompensation heart failure, and may be reflected in the electrical impedance of the patient’s tissue. Tissue impedance may be measured, for example, by forcing a known electrical current through outer electrodes **103b** and **103c**, and measuring the voltage impressed between electrodes **103a** and **103d**. The current may be alternating current, at an excitation frequency selected to most effectively characterize the tissue hydration. More information about tissue hydration measurement may be found in U.S. Patent Application Publication No. 2009/0076345 previously incorporated by reference, and U.S. Patent Application Publication No. 2009/0076344 published March 19, 2009 and titled “Multi-Sensor Patient monitor to Detect Impending Cardiac Decompensation”, the entire disclosure of which is incorporated by reference herein for all purposes.

[0051] Because tissue impedance is a slowly-changing parameter, impedance data need not be sampled as often as ECG data. For example, tissue impedance data samples may be taken

and stored at a sampling frequency of 0.1 to 10 Hz (one sample every 0.1 to 10 seconds), or at another suitable frequency. Note that this sampling frequency is independent of the excitation frequency of the AC current used in taking the impedance measurements.

[0052] Still another example of a physiological parameter that may be monitored using monitoring device **100** is the patient's respiration. For example, the patient's breathing rate, breath volume, or other breathing characteristics may be monitored. Such breathing parameters may also be relevant in the diagnosis or prediction of acute decompensated heart failure. For example, a trend toward an increased breathing rate combined with reduced breath volume, so-called "shallow" breathing may be suggestive of impending heart failure.

[0053] The patient's breathing rate and volume may also be inferable from tissue impedance measurements, as the tissue impedance observed by monitoring device **100** may vary by a measurable amount as the patient inhales and exhales. (These variations are preferably filtered out when characterizing the impedance itself.) Impedance variations occurring in the frequency range of normal breathing may be analyzed to characterize the patient's breathing. More information about the relationship of impedance and respiration may be found in U.S. Patent Application Publication No. 2011/0245711, published October 6, 2011 and titled "Method and Apparatus for Personalized Physiologic Parameters", the entire disclosure of which is incorporated by reference herein for all purposes.

[0054] Impedance samples for characterizing respiration may be taken and stored with a sampling frequency of 2 to 10 Hz, or another suitable sampling frequency. In one embodiment, data samples for measuring respiration are taken and stored with a sampling frequency of 4 Hz.

[0055] Other examples of physiological parameters that may be monitored using monitoring device **100** are aspects of the patient's orientation, activity, or other parameters that may be measured using accelerometer **313**. For example, signals produced by accelerometer **313** may be used to determine if the patient is lying down or is upright. In addition, the signals may be used to determine the patient's activity level, for example whether the patient is sedentary, exercising, or the like. In some cases, the intensity or type of exercise may be ascertainable from the accelerometer signals. Certain abrupt accelerometer signals may indicate that the patient has fallen.

[0056] Accelerometer signals may be taken and stored with a sampling frequency of 0.1 to 10 Hz, or another suitable sampling frequency. In one embodiment, data samples from

accelerometer **313** are taken and stored with a sampling frequency of 0.25 Hz, or one sample every 4 seconds.

[0057] In addition to storing sampled data from the various sensors on monitoring device **100**, processor **307** may continually monitor and analyze the sampled data to detect physiological events of patient **401**. For example, the ECG samples may be compared with templates characterizing different possible arrhythmias, and the occurrence of an arrhythmia may be considered an event. In another example, ongoing impedance measurements may indicate that the patient's tissue hydration has elevated above a predetermined threshold value, as compared with a baseline value measured at the beginning of the monitoring period. Because of the significance of tissue hydration in acute decompensated heart failure, this rise in tissue hydration may be considered a significant physiological event. In another example, an accelerometer reading that indicates that the patient has fallen may be considered a physiological event.

[0058] Event recognitions may also be derived from combinations of sensor data. For example, a rise in tissue hydration combined with a reduction in breath volume as compared with baseline values may be considered a physiological event. In another example, an increase in heart rate as indicated by the ECG data that is not accompanied by a commensurate increase in physical activity as indicated by signals from accelerometer **313** may be considered a physiological event. Many other event definitions are possible.

[0059] Example monitoring device **100** can report some or all detected events as the events occur, via wireless communication circuitry **310**. When a particular arrhythmia is detected, monitoring device **100** may transmit a report of the physiological event via wireless communication circuitry **310** to an external device.

[0060] Referring again to FIG. 4, monitoring device **100** may report event indications to a remote server **402** via an intermediate device **403**. For the purposes of this disclosure, either remote server **402** or intermediate device **403** may be considered an "external device" with which monitoring device **100** communicates.

[0061] Intermediate device **403** may communicate with monitoring device **100** wirelessly via link **404**, which may be a short-range wireless link such as a Bluetooth[®], ZigBee[®], Wi-Fi[®] or other kind of standard or proprietary wireless link. In turn, intermediate device **403** communicates with remote server **402** using communication link **405**, which may be a wide-area wireless connection such as a cellular telephone connection, or may be a wired connection. This arrangement enables patient **401** to go about his or her daily activities while

monitoring is ongoing and events are reported. Remote server **402** may be, for example, at a monitoring facility, health care facility, or any other location worldwide where link **405** can be made. In other uses, remote server **402** may be adjacent patient. In some embodiments, no intermediate device may be necessary, and monitoring device **100** may communicate directly with a server that receives event reports.

[**0062**] In FIG. 4, intermediate device **403** is depicted as being connected to mains power outlet **406**. For example, patient **401** may plug in intermediate device **403** at the patient's home or office. In other embodiments, intermediate device may also or alternatively be battery powered, enabling further flexibility on the part of patient. For example, patient **401** may carry a battery powered intermediate device **403** while going about daily errands. So long as link **405** is maintained, for example so long as patient **401** remains in an area with cellular telephone coverage, event reports can be transmitted promptly to remote server **402**.

[**0063**] An event report may indicate that an event has been detected, may describe the event, and may also include a portion ("snippet") of the sampled data that prompted the event report. For example, if analysis of a portion of the sampled ECG determines that a particular arrhythmia has occurred, the event report may simply indicate that the arrhythmia was detected at a certain time. However, in some embodiments, report may also include sampled ECG data showing the arrhythmia occurring. A physician or other health care professional may use the transmitted data to verify that the event actually occurred, to evaluate the severity of the event, or for other purposes.

[**0064**] Even if events are not detected, monitoring device **100** may periodically report to remote server. For example, during ECG monitoring, monitoring device **100** may send an ECG data snippet after a predetermined time has elapsed without any event detections. The predetermined time may be any suitable interval, for example one hour, two hours, four hours, or another interval.

[**0065**] Patient **401** may also be able to trigger the sending of a data snippet using button **112**. Considered another way, a press of button **112** may be considered an event, to which monitoring device **100** reacts by transmitting a data snippet. For example, if patient **401** experiences a symptom that he or she suspects may be related to the condition for which he or she is being monitored, patient **401** can press button **112**, to cause monitoring device **100** to send data encompassing the time just before the button press to remote server **402** and preferably a period of time after the button press. For example, upon a press of button **112**, monitoring device **100** may record an additional 30 seconds of data, and then transmit to

server **402** 45 seconds of data, including the 15 seconds before and the 30 seconds after the press of button **112**. Of course, other intervals may be used, and the time period before the button press for which data is transmitted need not be the same as the time period after the button press for which data is transmitted. Examples of symptoms that may prompt a patient to press button **112** may include dizziness, syncope, chest pain, shortness of breath, or other symptoms.

[0066] Button **112** may activate a simple mechanical switch that makes or breaks electrical contacts as shown in FIG. 3, or may be another kind of input device. For example, button **112** may be implemented with a magnetic detector such as a Hall effect sensor coupled to processor **307**, and the user may signal monitoring device **100** to capture and send a snippet of data by placing a magnet near reusable portion **102**. In some embodiments, monitoring device **307** may preferably provide feedback to the user regarding the request to transmit a data snippet. For example, monitoring device may flash light source **314** or generate a sound using sound generator **315** to signal the user. Monitoring device **100** may signal the user of such events as that the button press or other request signal was received, that the data snippet was collected and sent, or other aspects of snippet collection and transmission.

[0067] In some embodiments, communication between remote server **402** and monitoring device **100** may be bidirectional. This capability may be used for a variety of purposes. For example, remote server **402** may download software updates to monitoring device **100**, for upgrading the capabilities of monitoring device **100**, for configuring monitoring device **100** to perform a different kind of monitoring than it has been performing, or for other purposes. In one example scenario, a data snippet transmitted as a result of a press of button **112** by patient **401** may prompt a reviewing physician to suspect a medical condition that had previously not been suspected for patient **401**. In that case, remote server may send commands to monitoring device **100** reconfiguring it to add monitoring additional physiological parameters.

[0068] In another use of bidirectional communication, remote server may request snippets of sampled data “on demand” by sending requests to monitoring device **100**. For example, a physician reviewing an event report sent by monitoring device **100** may wish to see more ECG data than was sent by monitoring device with the event report, or may wish to see data from a different kind of sensor present on monitoring device. In an example scenario, patient **401** may feel dizzy and press button **112**, prompting monitoring device **100** to send a snippet of ECG data to remote server **402**. If a review of the data snippet does not reveal any

abnormality that might explain the patient's symptoms, a reviewing physician may request that respiration and activity data from just before the time of the button press also be transmitted, in case the additional data might assist in determining the cause of the patient's symptoms.

[0069] In some embodiments, monitoring device **100** or remote server **402** may monitor the quality of the electrode contact with the patient's skin. For example, if monitoring device **100** or remote server **402** receives a tissue impedance reading that is higher than normal bounds for human tissue, the reading may be flagged as possibly indicating a loss of contact between the patient's skin and one or more of electrodes **103a-103d**. Any of various actions may be taken upon the suspected detection of a loss of electrode contact. For example, monitoring device **100** may use light source **314** or sound generator **315** to signal a potential problem to the patient, using a light pattern, light color, or sound that signals the user to contact a help line for instructions about responding to the problem. In another scenario, remote server **402** may flag the potential loss of contact, and a customer service representative may call the patient directly to ask what may have precipitated the suspect reading or readings. If electrode contact has been lost, the patient may be directed to visit a clinic or other medical facility for replacement of disposable portion **101**. In some embodiments, a single suspect impedance reading may not trigger intervention, but action may be taken if the elevated impedance persists for a predetermined period, for example a few minutes to a few hours.

[0070] In some embodiments, monitoring device **100** can be used for extended monitoring through the use of multiple disposable portions **101** with a single reusable portion **102**. For example, each disposable portion **101** may have a usable life shorter than the period for which monitoring is desired. In some embodiments, each disposable portion **101** can be used for over one week or more, for example 180 hours or more, without replacement. The useful life of disposable portion **101** may be limited by the capacity of battery **301**, the ability of the adhesive holding the device to the patient's skin to maintain good electrical contact between electrodes **103a-103d** and the patient's skin, and other factors.

[0071] When a disposable portion **101** has reached the end of its useful life, the patient preferably returns to a clinic or other medical facility for replacement of disposable portion **101**. Monitoring device **100** is removed from the patient's skin, and reusable portion **102** is separated from disposable portion **101**. In some embodiments, the separation of disposable and reusable portions **101** and **102** renders disposable portion **101** unusable. For example, the

act of removing reusable portion **102** may damage electrical traces within disposable portion **101**, may damage the mechanical features that hold the two portions together, or may cause other damage to disposable portion **101**. Rendering disposable portion **101** unusable discourages attempted reuse of disposable portion **101**, which could result in unreliable monitoring.

[0072] If a reused disposable portion **101** were to be assembled with a particular reusable portion **102**, the attempted reuse may be detected. For example, if the reused disposable portion **101** has not been paired with the particular reusable portion **102**, the reusable portion **102** may refuse to operate or may report the mismatch. Or data transfers from monitoring device **100** may include the unique identifiers of disposable portion **101** and reusable portion **102**, and remote server **402** may detect the reuse when data is received bearing a disposable portion identifier for which data already exists from a prior monitoring session.

[0073] During the replacement process, the sampled data stored in reusable portion **102** may be read through connector **312**. For example, a suitable cable may be attached between connector **312** and a computer system or other reader, and the data transferred to the reading device. In other embodiments, reusable portion **102** may be placed in a reading device configured to make contact with connector **312** on reusable portion **102**. The reading device may be connected to a computer system that ultimately receives the data. Preferably, the retrieved data is associated with any event reports and data snippets received during monitoring of patient **401**.

[0074] As will be appreciated, monitoring device **100** may thus make efficient use of resources, while communicating potentially urgent information in real time. The ongoing analysis of the sampled data and real time reporting of physiological events ensures that potentially urgent or significant events can be reviewed nearly as they occur. Thus, it may be unnecessary to transmit the entire set of sampled data wirelessly. In any event, transmitting the entire sampled data set wirelessly may be expensive or impracticable. However, the data may be useful for further analysis of the patient's condition, and it is therefore valuable for the data to be preserved and stored. Since urgent situations can be addressed with event reports and possible "on demand" retrieval of additional sampled data, it may not be urgent for the complete data to reach server **402** or another storage site. Transferring the complete data via cable or other wired connection during an office visit may complete the transfer quickly and at low cost.

[0075] Reusable portion **102** can then be assembled into a new disposable portion **101**, and the resulting monitoring device **100** can be re-adhered to the patient's skin. Upon each reassembly, reusable portion **102** retrieves the unique identifier **303** of the new disposable portion **101** and a check is made, for example by reusable portion **102** or remote server **402**. Monitoring can then continue for another period, up to the useful life of the new disposable portion **101**. Many changes of disposable portion **101** may be performed, so that a patient may be monitored for up to 90 days or more.

[0076] Once monitoring of a patient is completed, reusable portion **102** may be cleaned, for example disinfected, so that it can be reused with a different patient. The architecture of monitoring device **100** may enable reusable portion **102** to be sealed from the external environment, and therefore able to withstand many cleaning and disinfection cycles so that reusable portion **102** can have an extended useful life. For example, because secondary battery **304** inside reusable portion **102** is re-charged from primary **301** in disposable portion **101**, there is no need to open reusable portion **102** to change secondary battery **304**. Also, since reusable portion **102** communicates wirelessly, the number of penetrations of the shell of reusable portion **102** is minimized.

[0077] In addition, the materials of the shell of reusable portion **102** may be selected to be compatible with one or more disinfectant solutions. Similarly, any adhesives used in the assembly of reusable portion **102** may be selected to be compatible with the disinfectant of choice. In some embodiments, a disinfectant and disinfection process may be selected in cooperation with the materials of reusable portion **102**, to ensure compatibility.

[0078] **FIG. 5** illustrates an exploded view of the construction of an embodiment of disposable portion **101** in more detail. Bottom layer **104**, previously described, includes an adhesive on its underside (not visible in **FIG. 5**). Bottom layer **104** includes openings **501a-501d** over which gels **502a-502d** are positioned. Gels **502a-502d** may be made, for example, of hydrogel adhesive 9880 available from the 3M Company of St. Paul, Minn., USA, or another suitable material.

[0079] An overlayer **503** is laminated to the top side of bottom layer **104**, constraining gels **502a-502d** and a flex circuit **504** between overlayer **503** and bottom layer **104**. Overlayer **503** is also breathable, having a high moisture vapor transmission rate, for example at least $100 \text{ g/m}^2/24\text{hrs}$, at least $400 \text{ g/m}^2/24\text{hrs}$, or another suitable value. Flex circuit **504** includes electrodes **103a-103d**. Finally, foam cover **505** bonds to the upper surface of overlayer **503**, and defines an opening for pocket **111**. The interior of pocket **111** is preferably defined by a

molded part held by foam cover **505**. Openings **506** remain open to the interior space formed between overlayer **503** and foam cover **505**.

[0080] **FIG. 6** illustrates an underside view of foam cover **505**, in accordance with embodiments.

[0081] **FIG. 7** illustrates a technique for rendering disposable portion **101** unusable when reusable portion **102** is removed, according to embodiments. In particular, **FIG. 7** provides a magnified cutaway illustrating the removal of disposable portion **101** from reusable portion **102** using tool **704**. As illustrated in the magnified cutaway portion, disposable portion **101** is configured to receive and retain reusable portion **102**. In particular, disposable portion **101** includes recess **701**, a ledge portion (not visible in this view) that engages snap feature **201** of reusable portion **102**, and enclosure walls **702** that intersect with recess **701** at corners **703**.

[0082] In one embodiment shown in **FIG. 7**, wall **702** is weaker than the walls of recess **701** or include thin or otherwise weakened areas. As a result, insertion of tool **704** through foam cover **505** and into recess **701** and application of force in the direction indicated by the arrow (i.e., downward rotating about the end of tool **704**), results in recess **701** being pried away from wall **702** and eventual breaking of a portion of wall **702**. As a result of the dislocation of wall **702**, the ledge is similarly displaced, such that snap feature **201** (shown in **FIG. 2A**) is no longer held in place by the ledge. The dislocation of the ledge is illustrated in additional detail in both the unbroken and broken states. In the process, the ledge for engaging snap feature **201** is displaced and no longer in position to hold reusable portion **102** in disposable portion **101**.

[0083] **FIGS. 8A and 8B** show top views of recess **701** and the breakage of wall **702**, resulting in the displacement of ledge **801**. In particular, **FIG. 8A** illustrates wall **702** in an unbroken state. As a result, ledge **801** is positioned to engage with snap feature **201** (not shown in this view). Recess **701** is clearly shown, including a portion of recess **701** configured to receive tool **704**. **FIG. 8B** illustrates wall **702** in a broken state, as a result of tool **704** being placed into recess **701**, and rotated in a downward (in this view, to the right) direction until the applied force causes wall **702** to break. As a result of wall **702** breaking, ledge **801** is displaced at an angle downward and to the right, such that ledge **801** no longer engages snap feature **201**. As a result, reusable portion **102** can be removed from disposable portion **101**, and disposable portion **101** is discarded. A benefit of this embodiment is disposable portion **101** can no longer be used to retain reusable portion **101**, and therefore must be discarded as desired.

[0084] According to one embodiment of the present invention, a monitoring device for monitoring one or more physiological parameters of a patient includes a disposable portion and a reusable portion. The disposable portion comprises at least two electrodes for coupling to the skin of the patient, a primary battery, and a first set of electrical contacts. The reusable portion comprises a processor, memory, a second set of electrical contacts, and sensing circuitry coupled to the at least two electrodes, wherein the reusable portion is mechanically coupleable to the disposable portion and wherein the reusable portion is electrically coupleable to the disposable portion through the first and second electrical contacts. When the reusable portion and the disposable portion are electrically coupled through the first and second electrical contacts, signals from the at least two electrodes are passed to the sensing circuitry and processed by the processor, and wherein the sensing circuitry and the processor are powered from the primary battery through the coupled first and second electrical contacts. When the reusable portion and the disposable portion are mechanically uncoupled after having been mechanically coupled, the disposable portion is rendered unusable by the process of mechanically uncoupling the reusable portion and the disposable portion.

[0085] The monitoring device of the preceding paragraph may optionally include, additionally and/or alternatively, one or more of the following features, configurations and/or additional components.

[0086] The reusable portion and the disposable portion may be separable, wherein the reusable portion may be used with a different disposable portion.

[0087] In any of the preceding embodiments, the reusable portion may comprise a real time clock and a secondary battery that powers the real time clock, and wherein when the reusable portion and the disposable portion are coupled through the first and second electrical contacts, the secondary battery is charged from the primary battery through the first and second electrical contacts.

[0088] In any of the preceding embodiments, the monitoring device may further comprise wireless communication circuitry through which information can be transmitted to an external device.

[0089] In any of the preceding embodiments, the processor may be programmed to: analyze data sampled from the signals from the electrodes; based on the analysis of the signals from the electrodes, identify a physiological event of the patient; and transmit a report of the physiological event via the wireless communication circuitry to the external device.

[0090] In any of the preceding embodiments, the processor may be configured to continuously record data sampled from the signals from the electrodes in the memory during monitoring.

[0091] In any of the preceding embodiments, the monitoring device may store the data in an encrypted form.

[0092] In any of the preceding embodiments, the processor may be configured to continuously transmit recorded data to an external device.

[0093] In any of the preceding embodiments, the monitoring device may further comprise a data interface comprising a connector, and wherein the continuously recorded data may be transmitted to the external device via a wired connection through the connector.

[0094] In any of the preceding embodiments, the processor may be configured to, during monitoring: receive, from an external device via the wireless communication circuitry, a request to transmit a portion of the continuously recorded data to the external device; and transmit the requested portion of the continuously recorded data to the external device via the wireless communication circuitry.

[0095] In any of the preceding embodiments, the one or more physiological parameters monitored by the monitoring device may include an electrocardiogram of the patient.

[0096] In any of the preceding embodiments, the one or more physiological parameters monitored by the monitoring device may include a tissue impedance the patient.

[0097] In any of the preceding embodiments, the one or more physiological parameters monitored may include a tissue hydration of the patient, and wherein the tissue hydration is derived from the tissue impedance the patient.

[0098] In any of the preceding embodiments, the one or more physiological parameters monitored may include any two or more of the parameters selected from the group consisting of an electrocardiogram of the patient, a tissue impedance the patient, a tissue hydration of the patient, and an activity level of the patient.

[0099] In any of the preceding embodiments, the disposable portion may be rendered unusable by breaking a mechanical feature of the disposable portion.

[0100] In any of the preceding embodiments, the reusable portion may include a unique reusable portion identifier stored in the reusable portion and accessible to the processor; and the disposable portion includes a unique disposable portion identifier stored in the disposable portion and accessible to the processor

[0101] In any of the preceding embodiments, the reusable portion may be capable of withstanding multiple cleaning and disinfection cycles without compromising the usability of the device

[0102] In any of the preceding embodiments, when the reusable portion and the disposable portion are coupled together, the device may be capable of withstanding being splashed with water without compromising the usability of the device

[0103] In any of the preceding embodiments, the processor may be initially programmed such that the device is configured to monitor a particular set of one or more physiological parameters, and wherein the processor can be reprogrammed such that the device is configured to monitor a different set of one or more physiological parameters.

[0104] According to another embodiment of the present invention, a monitoring device for monitoring one or more physiological parameters of a patient includes a disposable portion and a reusable portion. The disposable portion includes at least two electrodes for coupling to the skin of the patient, and a first set of electrical contacts. The reusable portion includes a processor, memory, a second set of electrical contacts, and sensing circuitry coupled to the at least two electrodes, wherein the reusable portion is mechanically coupleable to the disposable portion and wherein the reusable portion is electrically coupleable to the disposable portion through the first and second electrical contacts. When the reusable portion and the disposable portion are electrically coupled through the first and second electrical contacts, signals from the at least two electrodes are passed to the sensing circuitry and processed by the processor. In addition, the reusable portion includes a unique reusable portion identifier stored in the reusable portion and accessible to the processor, and the disposable portion includes a unique disposable portion identifier stored in the disposable portion and accessible to the processor.

[0105] According to another embodiment of the present invention, a monitoring device for monitoring one or more physiological parameters of a patient includes a disposable portion and a reusable portion. The disposable portion includes at least two electrodes for coupling to the skin of the patient, and a first set of electrical contacts. The reusable portion includes a processor, memory, a second set of electrical contacts, sensing circuitry coupled to the at least two electrodes, wireless communication circuitry through which information can be transmitted to an external device, and a data interface comprising a connector for transmitting data via wired connection using the connector. The reusable portion is mechanically coupleable to the disposable portion and wherein the reusable portion is electrically

coupleable to the disposable portion through the first and second electrical contacts. When the reusable portion and the disposable portion are electrically coupled through the first and second electrical contacts, signals from the at least two electrodes are passed to the sensing circuitry and processed by the processor.

[0106] According to another embodiment of the present invention, a monitoring device for monitoring one or more physiological parameters of a patient includes a disposable portion and a reusable portion. The disposable portion includes at least two electrodes for coupling to the skin of the patient, a primary battery, and a first set of electrical contacts. The reusable portion comprising a processor, memory, a second set of electrical contacts, a secondary battery, a real time clock powered by the secondary battery, and sensing circuitry coupled to the at least two electrodes. The reusable portion is mechanically coupleable to the disposable portion and wherein the reusable portion is electrically coupleable to the disposable portion through the first and second electrical contacts. When the reusable portion and the disposable portion are electrically coupled through the first and second electrical contacts, signals from the at least two electrodes are passed to the sensing circuitry and processed by the processor. The sensing circuitry and the processor are powered from the primary battery through the coupled first and second electrical contacts. When the reusable portion and the disposable portion are coupled through the first and second electrical contacts, the secondary battery is charged from the primary battery through the first and second electrical contacts.

[0107] According to another embodiment of the present invention, a monitoring device for monitoring one or more physiological parameters of a patient includes a disposable portion and a reusable portion. The disposable portion includes at least two electrodes for coupling to the skin of the patient, a battery, and a first set of electrical contacts. The reusable portion includes a processor, memory, a second set of electrical contacts, and sensing circuitry coupled to the at least two electrodes. The reusable portion is mechanically coupleable to the disposable portion such that when the reusable portion and the disposable portion are mechanically coupled they form a water-resistant unit, and wherein the reusable portion is electrically coupleable to the disposable portion through the first and second electrical contacts. When the reusable portion and the disposable portion are electrically coupled through the first and second electrical contacts, signals from the at least two electrodes are passed to the sensing circuitry and processed by the processor. The sensing circuitry and the processor are powered from the battery through the coupled first and second electrical

contacts. The reusable portion and the disposable portion are separable, and wherein the reusable portion can be used with a different disposable portion.

[0108] The monitoring device of the preceding paragraph may optionally include, additionally and/or alternatively, one or more of the following features any of the preceding embodiments.

[0109] For example, the battery may be a primary battery.

[0110] In any of the preceding embodiments, the reusable portion may include a real time clock and a secondary battery that powers the real time clock, and wherein when the reusable portion and the disposable portion are coupled through the first and second electrical contacts, the secondary battery is charged from the primary battery through the first and second electrical contacts.

[0111] In any of the preceding embodiments, the reusable portion may further include wireless communication circuitry through which information can be transmitted to an external device.

[0112] In any of the preceding embodiments, the processor may be programmed to: analyze data sampled from the signals from the electrodes; based on the analysis of the signals from the electrodes, identify a physiological event of the patient; and transmit a report of the physiological event via the wireless communication circuitry to the external device.

[0113] In any of the preceding embodiments, the processor may be configured to cause data sampled from the signals from the electrodes to be continuously recorded in the memory during monitoring.

[0114] In any of the preceding embodiments, the data may be stored in an encrypted form.

[0115] In any of the preceding embodiments, the processor may be configured to transmit the continuously recorded data to an external device.

[0116] In any of the preceding embodiments, the monitoring device may further include a data interface that includes a connector, and wherein the continuously recorded data is transmitted to the external device via a wired connection through the connector.

[0117] In any of the preceding embodiments, the processor may be configured to, during monitoring: receive, from an external device via the wireless communication circuitry, a request to transmit a portion of the continuously recorded data to the external device; and transmit the requested portion of the continuously recorded data to the external device via the wireless communication circuitry.

[0118] In any of the preceding embodiments, the one or more physiological parameters monitored may include an electrocardiogram of the patient.

[0119] In any of the preceding embodiments, the one or more physiological parameters monitored may include a tissue impedance the patient.

[0120] In any of the preceding embodiments, the one or more physiological parameters monitored may include a tissue hydration of the patient, and wherein the tissue hydration is derived from the tissue impedance the patient.

[0121] In any of the preceding embodiments, the one or more physiological parameters monitored may include any two or more of the parameters selected from the group consisting of an electrocardiogram of the patient, a tissue impedance the patient, a tissue hydration of the patient, and an activity level of the patient.

[0122] In any of the preceding embodiments, the disposable portion may be rendered unusable by breaking a mechanical feature of the disposable portion.

[0123] In any of the preceding embodiments, the reusable portion may further include a unique reusable portion identifier stored in the reusable portion and accessible to the processor; and the disposable portion includes a unique disposable portion identifier stored in the disposable portion and accessible to the processor.

[0124] In any of the preceding embodiments, the reusable portion may be capable of withstanding multiple cleaning and disinfection cycles without compromising the usability of the device.

[0125] In any of the preceding embodiments, when the reusable portion and the disposable portion are coupled together, the device may be able to withstand being splashed with water without compromising the usability of the device.

[0126] In any of the preceding embodiments, the processor may be initially programmed such that the device is configured to monitor a particular set of one or more physiological parameters, and wherein the processor may be reprogrammed such that the device is configured to monitor a different set of one or more physiological parameters.

[0127] According to another embodiment of the present invention, A monitoring device for monitoring an electrocardiogram of the patient may include a disposable portion and a reusable portion. The disposable portion may include a shell having a bay and a first surface for adhering to the skin of a patient. The disposable portion may include at least two skin electrodes on the first surface of the shell, a battery housed within the shell, and a first set of electrical contacts within the bay and in electrical communication with the battery and the

skin electrodes. The reusable portion may be releasably received and mechanically coupled within the bay of the disposable portion, the reusable portion comprising a monitoring circuit and a second set of electrical contacts in electrical communication with the monitoring circuit; the bay of the disposable portion and the reusable portion including interlocking features that releasably lock the reusable portion in the bay of the disposable portion with the second set of electrical contacts in electrical contact with the first set of electrical contacts such that the skin electrodes and battery of the disposable portion are in electrical communication with the monitoring circuit of the reusable portion.

[0128] In any of the preceding embodiments, the shell of the disposable portion may have a second surface and a frame extending into the shell from the second surface to define the bay, the first and second surfaces being formed of one or more flexible, breathable materials, the frame and reusable portion being rigid relative to the first and second surfaces of the disposable portion such that the monitoring device is adapted to conform to the skin of a patient.

[0129] In any of the preceding embodiments, the bay may include first and second ends, the first set of electrical contacts being arranged along the first end, the interlocking features including a breakable feature arranged along the second end.

[0130] In any of the preceding embodiments, the first surface of the disposable portion may be formed of material having a high moisture vapor transmission rate.

[0131] In any of the preceding embodiments, the first surface of the disposable portion may be formed of material having a moisture vapor transmission rate of at least $100 \text{ g/m}^2/24\text{hrs}$.

[0132] In any of the preceding embodiments, the moisture vapor transmission rate may be at least $400 \text{ g/m}^2/24\text{hrs}$.

[0133] In any of the preceding embodiments, the first surface of the disposable portion may include skin adhesive material for adhering the first surface to the skin of patient.

[0134] In any of the preceding embodiments, the reusable portion may include a sealed housing, and the first and second surfaces of the disposable portion are breathable.

[0135] In one embodiment, a method of using the monitoring device described in a previous embodiment may include removing the reusable portion from the disposable portion after a use of the monitoring device and replacing the disposable portion.

[0136] The invention has now been described in detail for the purposes of clarity and understanding. However, those skilled in the art will appreciate that certain changes and modifications may be practiced within the scope of the appended claims.

WHAT IS CLAIMED IS:

1. A monitoring device for monitoring one or more physiological parameters of a patient, the monitoring device comprising:
 - a disposable portion comprising at least two electrodes for coupling to the skin of the patient, a battery, and a first set of electrical contacts; and
 - a reusable portion comprising a processor, memory, a second set of electrical contacts, and sensing circuitry coupled to the at least two electrodes, wherein the reusable portion is mechanically coupleable to the disposable portion and wherein the reusable portion is electrically coupleable to the disposable portion through the first and second electrical contacts;wherein when the reusable portion and the disposable portion are electrically coupled through the first and second electrical contacts, signals from the at least two electrodes are passed to the sensing circuitry and processed by the processor;
wherein the sensing circuitry and the processor are powered from the battery through the coupled first and second electrical contacts; and
wherein when the reusable portion and the disposable portion are mechanically uncoupled after having been mechanically coupled, the disposable portion is rendered unusable by the process of mechanically uncoupling the reusable portion and the disposable portion.
2. The monitoring device of claim 1, wherein the reusable portion and the disposable portion are separable, and wherein the reusable portion can be used with a different disposable portion.
3. The monitoring device of any of claims 1 and 2, wherein the battery is a primary battery.
4. The monitoring device of any of claims 3, wherein the reusable portion comprises a real time clock and a secondary battery that powers the real time clock, and wherein when the reusable portion and the disposable portion are coupled through the first and second electrical contacts, the secondary battery is charged from the primary battery through the first and second electrical contacts.

5. The monitoring device of any of claims 1-4, wherein the disposable portion is rendered unusable by breaking a mechanical feature of the disposable portion.
6. The monitoring device of any of claims 1-5, wherein:
the reusable portion includes a unique reusable portion identifier stored in the reusable portion and accessible to the processor; and
the disposable portion includes a unique disposable portion identifier stored in the disposable portion and accessible to the processor.
7. The monitoring device of any of claims 1-6, wherein the reusable portion can withstand multiple cleaning and disinfection cycles without compromising the usability of the device.
8. The monitoring device of any of claims 1-7, wherein when the reusable portion and the disposable portion are coupled together, the device can withstand being splashed with water without compromising the usability of the device.
9. The monitoring device of any of claims 1-8, wherein the reusable portion further includes wireless communication circuitry through which information can be transmitted to an external device, and a data interface comprising a connector for transmitting data via wired connection using the connector.
10. A monitoring device for monitoring one or more physiological parameters of a patient, the monitoring device comprising:
a disposable portion comprising at least two electrodes for coupling to the skin of the patient, a battery, and a first set of electrical contacts; and
a reusable portion comprising a processor, memory, a second set of electrical contacts, and sensing circuitry coupled to the at least two electrodes, wherein the reusable portion is mechanically coupleable to the disposable portion such that when the reusable portion and the disposable portion are mechanically coupled they form a water-resistant unit, and wherein the reusable portion is electrically coupleable to the disposable portion through the first and second electrical contacts;
wherein when the reusable portion and the disposable portion are electrically coupled through the first and second electrical contacts, signals from the at least two electrodes are passed to the sensing circuitry and processed by the processor;

wherein the sensing circuitry and the processor are powered from the battery through the coupled first and second electrical contacts; and

wherein the reusable portion and the disposable portion are separable, and wherein the reusable portion can be used with a different disposable portion.

11. The monitoring device of claim 10, wherein the battery is a primary battery.
12. The monitoring device of claim 11, wherein the reusable portion comprises a real time clock and a secondary battery that powers the real time clock, and wherein when the reusable portion and the disposable portion are coupled through the first and second electrical contacts, the secondary battery is charged from the primary battery through the first and second electrical contacts.
13. The monitoring device of any of claims 10-12, wherein the disposable portion is rendered unusable by breaking a mechanical feature of the disposable portion.
14. The monitoring device of any of claims 10-13, wherein:
the reusable portion includes a unique reusable portion identifier stored in the reusable portion and accessible to the processor; and
the disposable portion includes a unique disposable portion identifier stored in the disposable portion and accessible to the processor.
15. The monitoring device of any of claims 10-14, wherein the reusable portion can withstand multiple cleaning and disinfection cycles without compromising the usability of the device.
16. The monitoring device of any of claims 10-15, wherein when the reusable portion and the disposable portion are coupled together, the device can withstand being splashed with water without compromising the usability of the device.
17. The monitoring device of any of claims 10-16, wherein the processor is initially programmed such that the device is configured to monitor a particular set of one or more

physiological parameters, and wherein the processor can be reprogrammed such that the device is configured to monitor a different set of one or more physiological parameters.

18. A monitoring device for monitoring an electrocardiogram of the patient, the monitoring device comprising:

a disposable portion comprising a shell having a bay and a first surface for adhering to the skin of a patient, the disposable portion including at least two skin electrodes on the first surface of the shell, a battery housed within the shell, and a first set of electrical contacts within the bay and in electrical communication with the battery and the skin electrodes; and

a reusable portion releasably received and mechanically coupled within the bay of the disposable portion, the reusable portion comprising a monitoring circuit and a second set of electrical contacts in electrical communication with the monitoring circuit;

wherein the bay of the disposable portion and the reusable portion include interlocking features that releasably lock the reusable portion in the bay of the disposable portion with the second set of electrical contacts in electrical contact with the first set of electrical contacts such that the skin electrodes and battery of the disposable portion are in electrical communication with the monitoring circuit of the reusable portion, wherein the bay includes first and second ends, the first set of electrical contacts being arranged along the first end, the interlocking features including a breakable feature arranged along the second end.

19. The monitoring device of claim 18, wherein the shell of the disposable portion has a second surface and a frame extending into the shell from the second surface to define the bay, the first and second surfaces being formed of one or more flexible, breathable materials, the frame and reusable portion being rigid relative to the first and second surfaces of the disposable portion such that the monitoring device is adapted to conform to the skin of a patient.

20. The monitoring device of any of claims 18-19, wherein the first surface of the disposable portion is formed of material having a high moisture vapor transmission rate.

1/6

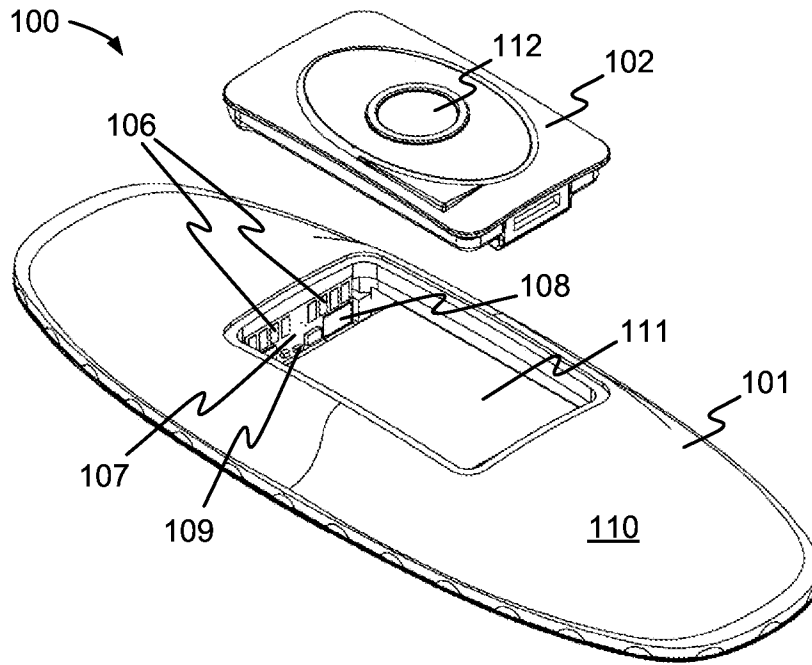

FIG. 1A

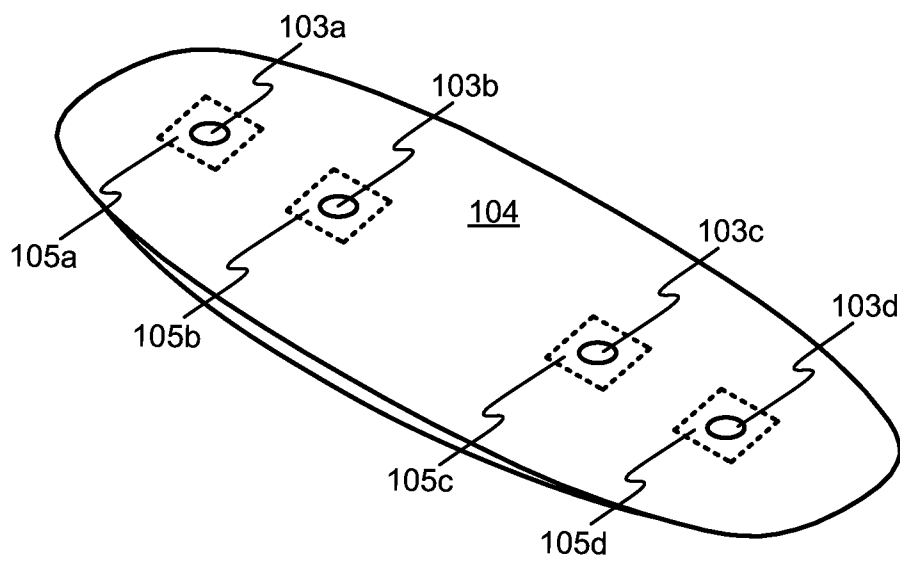

FIG. 1B

2/6

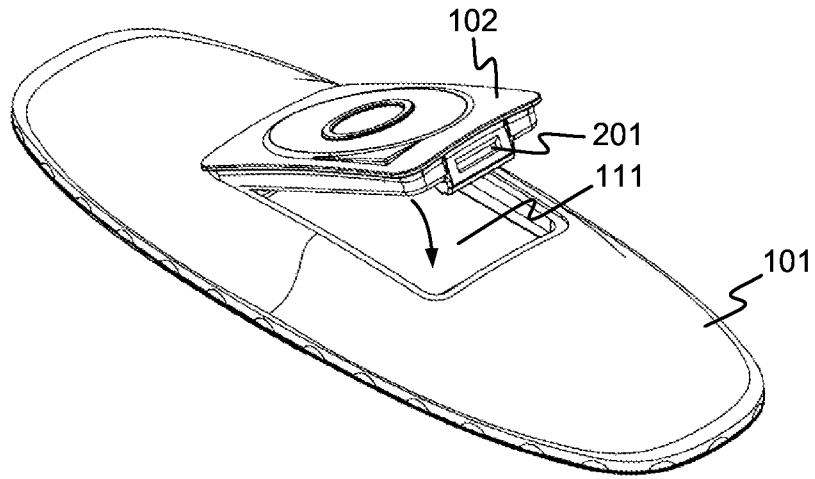

FIG. 2A

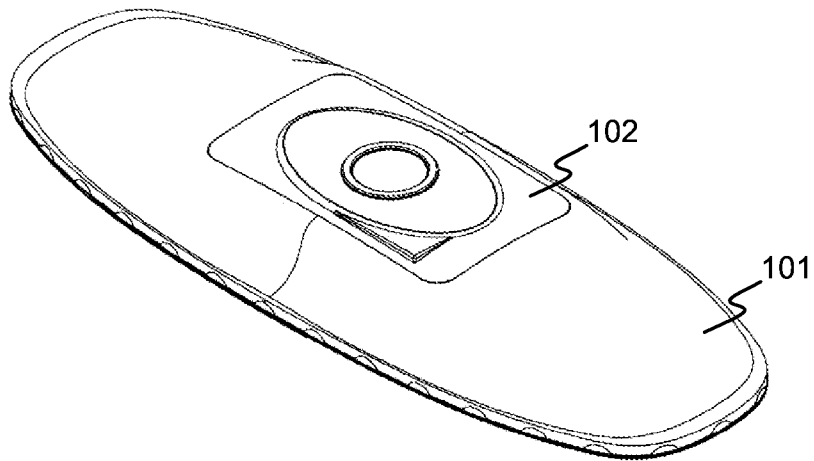

FIG. 2B

3/6

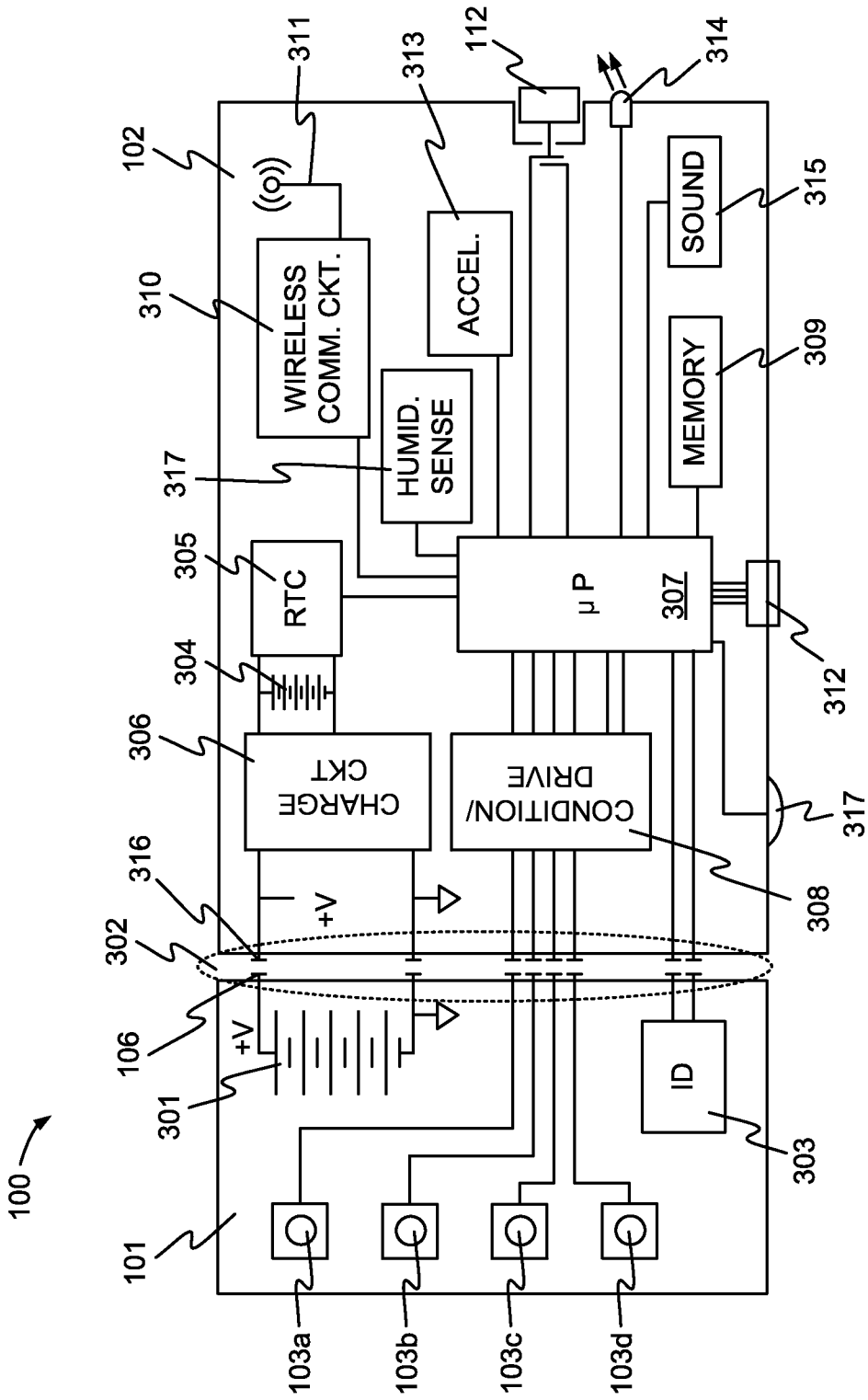

FIG. 3

4/6

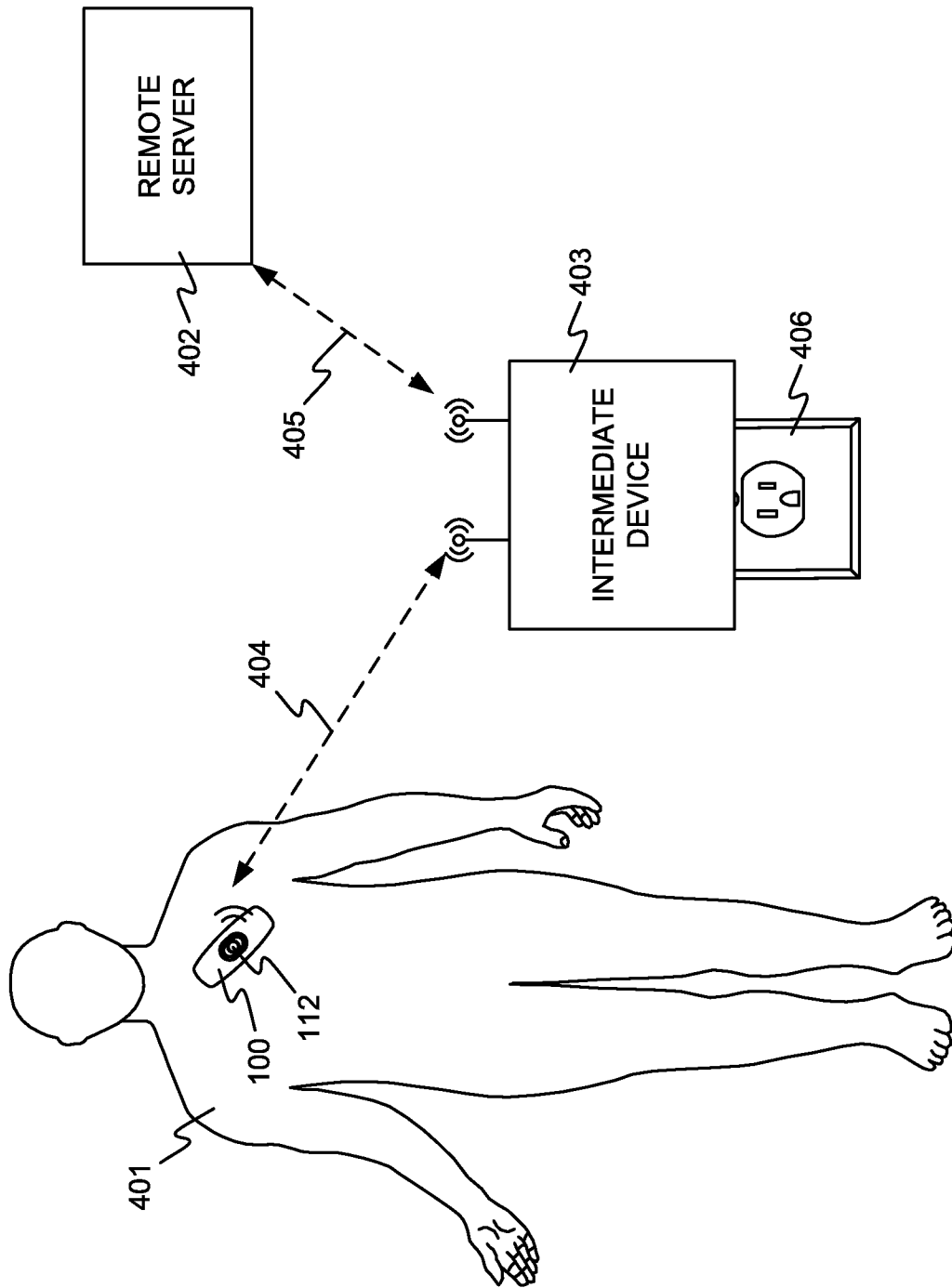

FIG. 4

5/6

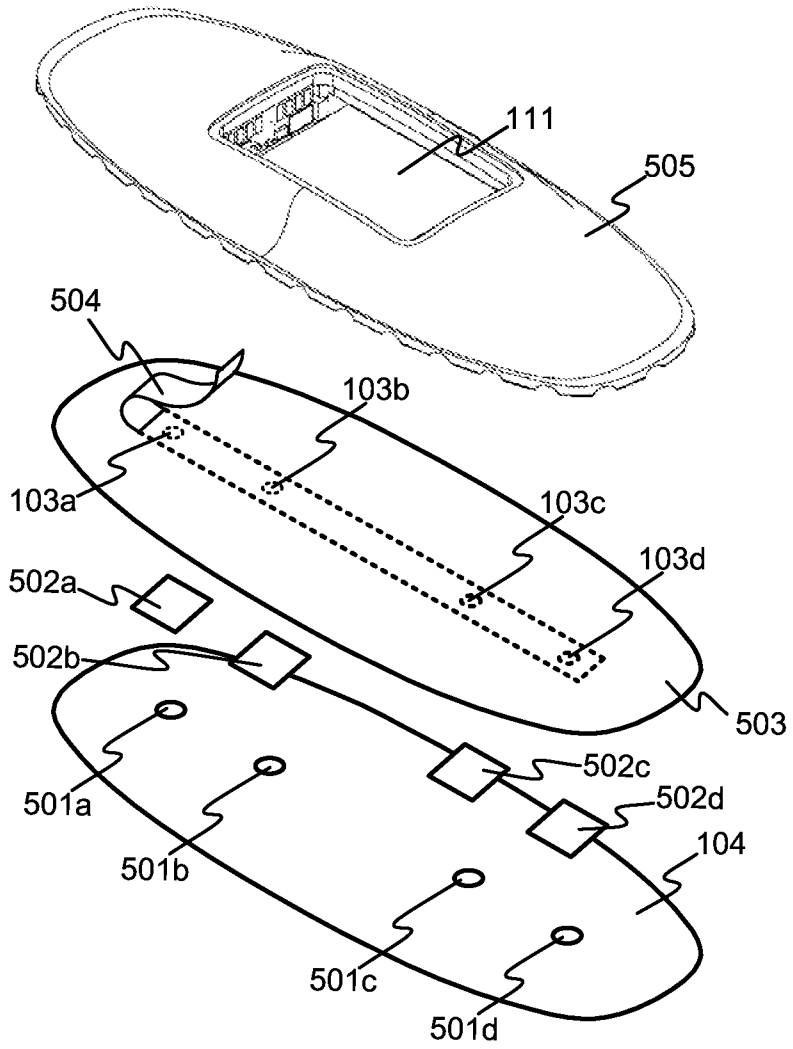

FIG. 5

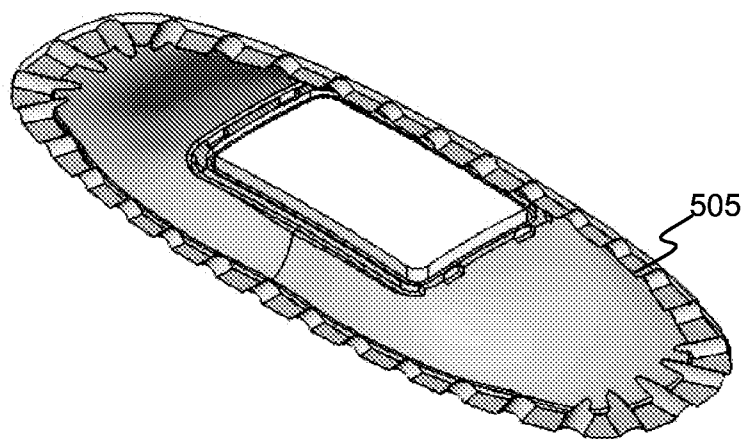

FIG. 6

6/6

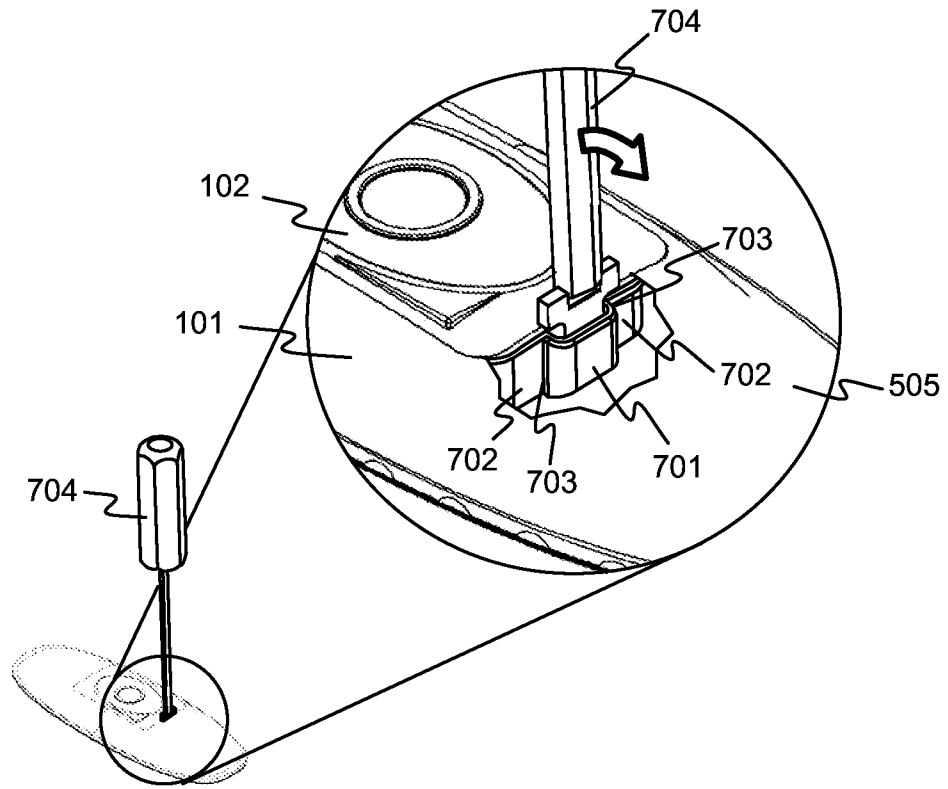
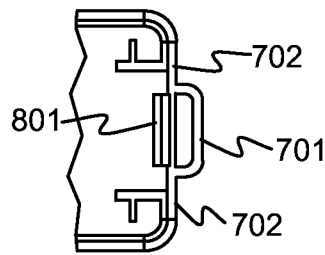
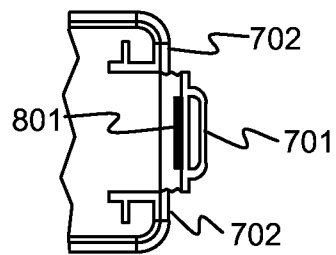

FIG. 7



UNBROKEN

FIG. 8A



BROKEN

FIG. 8B

A. CLASSIFICATION OF SUBJECT MATTER**A61B 5/00(2006.01)i**

According to International Patent Classification (IPC) or to both national classification and IPC

B. FIELDS SEARCHEDMinimum documentation searched (classification system followed by classification symbols)
A61B 5/00; A61B 5/04; A61B 5/0428; A61B 5/0452; A61B 5/0402; A61B 5/0408Documentation searched other than minimum documentation to the extent that such documents are included in the fields searched
Korean utility models and applications for utility models
Japanese utility models and applications for utility modelsElectronic data base consulted during the international search (name of data base and, where practicable, search terms used)
eKOMPASS(KIPO internal) & Keywords: electrode, disposable, reusable, battery**C. DOCUMENTS CONSIDERED TO BE RELEVANT**

Category*	Citation of document, with indication, where appropriate, of the relevant passages	Relevant to claim No.
Y	US 2008-0139953 A1 (STEVEN D. BAKER et al.) 12 June 2008 See abstract, paragraphs [0044]-[0071] and figures 1A-3,5.	1-3,10,11,13
A		4,12,18-20
Y	US 2009-0076340 A1 (IMAD LIBBUS et al.) 19 March 2009 See abstract, paragraph [0083] and figure 1I.	1-3,10,11,13
A	US 2013-0116533 A1 (JIE LIAN et al.) 09 May 2013 See abstract, paragraphs [0044]-[0047] and figures 1A-2B.	1-4,10-13,18-20
A	US 2010-0056896 A1 (IK RO PARK) 04 March 2010 See abstract, paragraphs [0023]-[0036] and figures 3-10.	1-4,10-13,18-20
A	US 2012-0101396 A1 (THOMAS SOLOSKO et al.) 26 April 2012 See abstract, paragraphs [0050]-[0060], claim 11 and figures 2-4.	1-4,10-13,18-20

 Further documents are listed in the continuation of Box C. See patent family annex.

* Special categories of cited documents:

"A" document defining the general state of the art which is not considered to be of particular relevance

"E" earlier application or patent but published on or after the international filing date

"L" document which may throw doubts on priority claim(s) or which is cited to establish the publication date of another citation or other special reason (as specified)

"O" document referring to an oral disclosure, use, exhibition or other means

"P" document published prior to the international filing date but later than the priority date claimed

"T" later document published after the international filing date or priority date and not in conflict with the application but cited to understand the principle or theory underlying the invention

"X" document of particular relevance; the claimed invention cannot be considered novel or cannot be considered to involve an inventive step when the document is taken alone

"Y" document of particular relevance; the claimed invention cannot be considered to involve an inventive step when the document is combined with one or more other such documents, such combination being obvious to a person skilled in the art

"&" document member of the same patent family

Date of the actual completion of the international search

04 June 2015 (04.06.2015)

Date of mailing of the international search report

10 June 2015 (10.06.2015)

Name and mailing address of the ISA/KR

International Application Division
Korean Intellectual Property Office
189 Cheongsu-ro, Seo-gu, Daejeon Metropolitan City, 302-701,
Republic of Korea

Facsimile No. +82-42-472-7140

Authorized officer

KIM, Tae Hoon

Telephone No. +82-42-481-8407

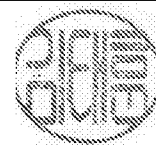

Box No. II Observations where certain claims were found unsearchable (Continuation of item 2 of first sheet)

This international search report has not been established in respect of certain claims under Article 17(2)(a) for the following reasons:

1. Claims Nos.:
because they relate to subject matter not required to be searched by this Authority, namely:

2. Claims Nos.:
because they relate to parts of the international application that do not comply with the prescribed requirements to such an extent that no meaningful international search can be carried out, specifically:

3. Claims Nos.: 5-9, 14-17
because they are dependent claims and are not drafted in accordance with the second and third sentences of Rule 6.4(a).

Box No. III Observations where unity of invention is lacking (Continuation of item 3 of first sheet)

This International Searching Authority found multiple inventions in this international application, as follows:

1. As all required additional search fees were timely paid by the applicant, this international search report covers all searchable claims.
2. As all searchable claims could be searched without effort justifying an additional fees, this Authority did not invite payment of any additional fees.
3. As only some of the required additional search fees were timely paid by the applicant, this international search report covers only those claims for which fees were paid, specifically claims Nos.:

4. No required additional search fees were timely paid by the applicant. Consequently, this international search report is restricted to the invention first mentioned in the claims; it is covered by claims Nos.:

Remark on Protest

- The additional search fees were accompanied by the applicant's protest and, where applicable, the payment of a protest fee.
- The additional search fees were accompanied by the applicant's protest but the applicable protest fee was not paid within the time limit specified in the invitation.
- No protest accompanied the payment of additional search fees.

INTERNATIONAL SEARCH REPORT

Information on patent family members

International application No.

PCT/US2015/016838

Patent document cited in search report	Publication date	Patent family member(s)	Publication date		
US 2008-0139953 A1	12/06/2008	CN 101534706 A	16/09/2009		
		CN 101534706 B	17/08/2011		
		EP 2081488 A2	29/07/2009		
		US 2012-0238890 A1	20/09/2012		
		US 2014-0100467 A1	10/04/2014		
		US 2014-0243694 A1	28/08/2014		
		US 8214007 B2	03/07/2012		
		US 8630699 B2	14/01/2014		
		US 8750974 B2	10/06/2014		
		US 8965492 B2	24/02/2015		
		WO 2008-057884 A2	15/05/2008		
		WO 2008-057884 A3	17/07/2008		
		US 2009-0076340 A1	19/03/2009	EP 2194856 A1	16/06/2010
				EP 2194856 A4	16/07/2014
US 2013-0338448 A1	19/12/2013				
US 8460189 B2	11/06/2013				
WO 2009-036306 A1	19/03/2009				
US 2013-0116533 A1	09/05/2013	EP 2589333 A1	08/05/2013		
US 2010-0056896 A1	04/03/2010	KR 10-1028584 B1	12/04/2011		
		KR 10-2010-0025321 A	09/03/2010		
		US 2012-0088396 A1	12/04/2012		
		US 8238998 B2	07/08/2012		
US 2012-0101396 A1	26/04/2012	CN 101984743 A	09/03/2011		
		CN 101984743 B	19/06/2013		
		EP 2262419 A2	22/12/2010		
		JP 2011-516110 A	26/05/2011		
		JP 5543380 B2	09/07/2014		
		WO 2009-112972 A2	17/09/2009		
		WO 2009-112972 A3	12/11/2009		