

(No Model.)

J. B. CLEVELAND.
WIRE STRETCHER.

No. 338,486.

Patented Mar. 23, 1886.

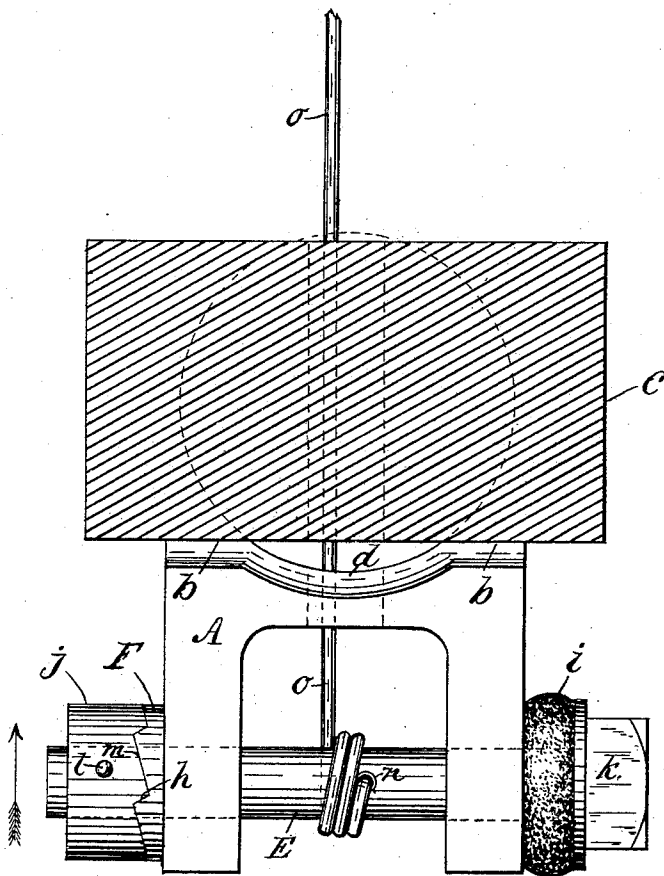

WITNESSES:

H. P. Hood,
Frank, A. Jacob,

INVENTOR:

John B. Cleveland

UNITED STATES PATENT OFFICE.

JOHN B. CLEAVELAND, OF INDIANAPOLIS, INDIANA.

WIRE-STRETCHER.

SPECIFICATION forming part of Letters Patent No. 338,486, dated March 23, 1886.

Application filed November 25, 1885. Serial No. 183,930. (No model.)

To all whom it may concern:

Be it known that I, JOHN B. CLEAVELAND, a citizen of the United States, residing at Indianapolis, in the county of Marion and State of Indiana, have invented a new and useful Improved Wire-Stretcher, of which the following is a specification.

My invention relates to that class of wire-stretchers which consist of a small windlass adapted to receive and hold the end of the fence-wire, and mounted upon the exterior of a fence-post, and arranged to stretch the fence-wire by drawing the end of the wire through the post and winding it about the windlass.

The object of my improvement is to construct the windlass so that it may be easily turned in a direction to wind the fence-wire upon it, and will retain the wire taut when so wound, but will yield to an extraordinary strain—as the contraction of the wire at a low temperature—and unwind sufficiently to prevent the breaking of the wire.

The accompanying drawing illustrates my invention.

The figure is a plan of the windlass and a section of a post.

A is a bracket, the base of which has plane surfaces *b b*, which adapt it to rest on the side of a rectangular fence-post, *c*, and a central curved surface, *d*, which adapt it to fit the curved side of a cylindrical post. (Indicated by dotted lines.)

E is a cylindrical spindle arranged to turn in bearings formed in bracket A.

F is a cylindrical boss formed on one side of bracket A, concentric with the spindle-bearing, and having in its outer face a series of ratchet-teeth, the retaining-face *h* of which is inclined backward at an obtuse angle, and the face *m* is inclined forward at an acute angle. Spindle E is provided at one end with a rectangular head, *k*, rigidly secured thereto or formed integral therewith, and an elastic washer, *i*, formed, preferably, of rubber, is placed upon the spindle between head *k* and bracket A. Upon the opposite end of the spindle is removably secured, by means of a pin, like *l*, a set-screw, or other suitable device, a collar, *j*, having upon one of its

sides ratchet-teeth corresponding to those of the boss F.

In putting the windlass together, washer *i* is compressed, so that when the collar *j* is secured the ratchet-teeth of said collar are drawn into close engagement with the ratchet-teeth on boss F by the recoil of the washer, and the washer is still further compressed when the spindle is turned in either direction by the riding of the ratchet-teeth of collar *j* over the corresponding ratchet-teeth of boss F. At about midway of the length of the spindle is a hole, *n*, passing diametrically through the spindle for the purpose of attaching the end of the fence-wire *o* to the spindle.

In operation, the fence-wire is passed through a suitable opening in the post, and also through the base of bracket A and into the hole in the spindle. A wrench is then applied to the head *k* of the spindle, and the spindle is turned in the direction indicated by the arrow, and the wire is wound upon the spindle until sufficiently taut, the acutely-inclined faces *m* of the ratchet-teeth in boss F and collar *j* easily overcoming the recoil of washer *i*. The faces *h* hold the spindle from turning backward under the ordinary strain of the wire, but, being slightly inclined backward, an extraordinary strain upon the wire will overcome the recoil of washer *i* and cause the spindle to turn backward a part of a revolution, thus unwinding the wire and relieving its tension.

I am aware that a cylindrical spindle having a fixed head, an elastic washer, and a removable head or collar having one side made concave to fit the exterior of a cylindrical tubular post, the spindle passing diametrically through the post and the fence-wire wound upon the spindle inside the post, have before been used, and form the subject-matter of another application for a patent by myself, No. 180,385, now pending, and I do not here claim anything therein shown; but

I claim as my invention—

The above-described portable wire-stretcher, consisting of the spindle having a fixed head and a removable collar, one side of which collar is provided with ratchet-teeth, means for securing said collar to the spin-

dle, the elastic washer, the supporting-bracket having bearings in which said spindle is arranged to revolve, and a ratchet-toothed boss thereon arranged to engage the ratchet-teeth
5 of said collar, said ratchet-teeth having backwardly-inclined retaining-faces, as shown and described, whereby the spindle is allowed to

turn backward, all combined and arranged to co-operate substantially as and for the purpose specified.

JOHN B. CLEVELAND.

Witnesses:

H. P. HOOD,
FRANK A. JACOB.