

(12) STANDARD PATENT
(19) AUSTRALIAN PATENT OFFICE

(11) Application No. **AU 2006201842 B8**

(54) Title
A two-step method of coating an article for security printing

(51) International Patent Classification(s)
B05D 3/14 (2006.01) **B42D 107/00** (2006.01)

(21) Application No: **2006201842** (22) Date of Filing: **2006.05.02**

(30) Priority Data

(31) Number (32) Date (33) Country
60/700,994 **2005.07.20** **US**

(43) Publication Date: **2007.02.08**

(43) Publication Journal Date: **2007.02.08**

(44) Accepted Journal Date: **2011.02.03**

(48) Corrigenda Journal Date: **2011.06.02**

(71) Applicant(s)
JDS Uniphase Corporation

(72) Inventor(s)
Coombs, Paul G.;Raksha, Vladimir P.;Argoitia, Alberto;Teitelbaum, Neil;Markantes, Charles T.

(74) Agent / Attorney
Fisher Adams Kelly, Level 29 12 Creek Street, Brisbane, QLD, 4000

(56) Related Art
US 3791864 A (STEINGROEVER) 12 February 1974
US 6759097 A (PHILLIPS ET AL.) 6 July 2004

Abstract of the Disclosure

5 A two-step method of making of a security printed image is disclosed and includes coating of the surface of a substrate with a predetermined image shape with an ink containing flaked magnetic pigment in a predetermined concentration, exposing a wet printed image to a magnetic field to align magnetic particles in a predetermined manner, allowing the ink to cure, and coating the substrate with a second printed image on the top of the first image. The second printed image with the same or different image shape is printed with another ink containing clear or dyed ink vehicle mixed with flaked magnetic pigment in a low concentration, exposed to the magnetic field of the same or different configuration as the first printed image and cured until the ink is dry.

15

Fig. 1

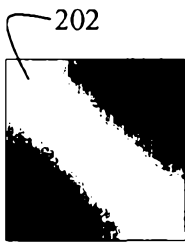

Fig. 2a

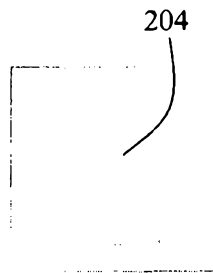

Fig. 2b

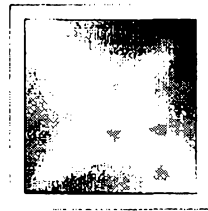

Fig. 2c

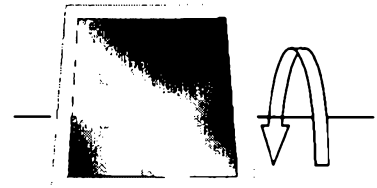

Fig. 2d

2006201842 02 May 2006

P/00/011
Regulation 3.2

AUSTRALIA

Patents Act 1990

**ORIGINAL
COMPLETE SPECIFICATION
STANDARD PATENT**

Invention Title: "A TWO-STEP METHOD OF COATING AN ARTICLE FOR SECURITY
PRINTING"

The following statement is a full description of this invention, including the best method
of performing it known to us:

TITLE

“A TWO-STEP METHOD OF COATING AN ARTICLE FOR SECURITY PRINTING”

CROSS-REFERENCE TO RELATED APPLICATIONS

5 This invention claims priority from US Provisional patent application No. 60/700,994 July 20, 2005, entitled “A Two-Step Method of Coating an Article for Security Printing”, which is incorporated herein by reference for all purposes.

FIELD OF THE INVENTION

10 This invention relates generally to a two-step method of making a security printed image and more particularly, to a method of forming the image by coating of the surface of the substrate with an ink containing alignable flaked material and exposing the coated surface to a magnetic or electric field so as to align at least some of the flaked material, and
15 subsequently re-coating the substrate with a second printed image over or under of the first image.

BACKGROUND OF THE INVENTION

 This invention relates to the coating of a substrate with an ink or paint or other similar medium to form an image exhibiting optically-illusive effects.
20 Many surfaces painted or printed with flat platelet-like particles show higher reflectance and brighter colors than surfaces coated with a paint or ink containing conventional pigments. Substrates painted or printed with color-shifting flaked pigments show change of color when viewed at different angles. Flaked pigments may contain a material that is magnetically
25 sensitive, so as to be alignable or orientable in an applied magnetic field. Such particles can be manufactured from a combination of magnetic and non-magnetic materials and mixed with a paint or ink vehicle in the production of magnetic paints or inks. A feature of these products is the ability of the flakes to become oriented along the lines of an applied field
30 inside of the layer of liquid paint or ink while substantially remaining in this position after drying or curing of the paint or ink vehicle. Relative orientation of the flake and its major dimension in respect to the coated surface

determines the level of reflectance or its direction and, or may determine the chroma of the paint or ink. Alternatively, dielectric material may be alignable in an electric field.

5 Alignment of magnetic particles along lines of applied magnetic field has been known for centuries and is described in basic physics textbooks. Such a description is found in a book by Halliday, Resnick, Walker, entitled, Fundamentals of physics. Sixth Edition, p. 662. It is also known to align dielectric particles in an electric field, and this form alignment is applicable to this invention.

10 The patents hereafter referred to are incorporated herein by reference for all purposes.

US Patent 3,853,676 in the name of Graves et al. describes painting of a substrate with a film comprising film-forming material and magnetically orientable pigment that is oriented in curved configurations and located in close proximity to the film, and that can be seen by the naked eye to provide awareness to the viewer of the location of the film.

15 US Patent 5,079,058 by Tomiyama discloses a patterned film forming a laminated sheet comprising a multi-layer construction prepared by successively laminating a release sheet layer, a pressure-sensitive adhesive layer, a base sheet layer, and a patterned film layer, or further laminating a pigmented print layer. The patterned film layer is prepared by a process which comprises coating a fluid coating composition containing a powdery magnetic material on one side of the base sheet layer to form a fluid film, and acting a magnetic force on the powdery magnetic material contained in the fluid film, in a fluid state, to form a pattern.

20 US Patent 5,364,689 in the name of Kashiwagi discloses a method and an apparatus for producing of a product having a magnetically formed pattern. The magnetically formed pattern becomes visible on the surface of the painted product as the light rays incident on the paint layer are reflected or absorbed differently by magnetic particles arranged in a shape corresponding to desired pattern. More particularly, Kashiwagi describes how

25

30

various patterns, caused by magnetic alignment of nickel flakes, can be formed on the surface of a wheel cover.

US Patent 6,808,806 by Phillips in the name of Flex Products Inc., discloses methods and devices for producing images on coated articles. The methods generally include applying a layer of magnetizable pigment coating
5 in liquid form on a substrate, with the magnetizable pigment coating containing a plurality of magnetic non-spherical particles or flakes. A magnetic field is subsequently applied to selected regions of the pigment coating while the coating is in liquid form, with the magnetic field altering the
10 orientation of selected magnetic particles or flakes. Finally, the pigment coating is solidified, affixing the reoriented particles or flakes in a non-parallel position to the surface of the pigment coating to produce an image such as a three dimensional-like image on the surface of the coating. The pigment coating can contain various interference or non-interference magnetic
15 particles or flakes, such as magnetic color shifting pigments.

US Patent 6,103,361 reveals patterned substrates useful in producing decorative cookware formed by coating a base with a mixture of fluoropolymer and magnetic flakes that magnetically induce an image in the polymer coating composition. The baked fluoropolymer release coating
20 contains magnetizable flakes. A portion of the flakes are oriented in the plane of the substrate and a portion of said flakes are magnetically reoriented to form a pattern in the coating which is observed in reflected light, the flakes having a longest dimension which is greater than the thickness of said coating. The patterned substrate is formed by applying magnetic force
25 through the edges of a magnetizable die positioned under a coated base to induce an imaging effect or pattern.

A common feature of the above-mentioned prior art references is a formation of different kinds of patterns in a painted or printed layer. Most of the patterns exist as indicia such as symbols, shapes, signs, or letters; and
30 these patterns replicate the shape of a magnet often located beneath the substrate and are formed by shadowing contour lines appearing in the layer of paint or ink resulting in particular alignments of magnetic flakes. The

desired pattern becomes visible on the surface of the painted product as the light rays incident on the paint layer are reflected or absorbed differently by the subgroup of magnetic non-spherical particles.

5 Although these prior art references provide some useful and interesting optical effects, there is a need for patterns which have a greater degree of optical illusivity, and which are more difficult to counterfeit. United States patent application number 20050106367, filed December 22, 2004 in the name of Raksha et al. entitled Method and Apparatus for Orienting Magnetic Flakes describes several interesting embodiments which provide
10 optical illusivity, such as a "rolling-bar" and a "flip-flop" which may serve as the basis of embodiments of this invention. Notwithstanding, there is need to provide different patterns on a single substrate wherein two coatings yield images that appear to move independently of one another as the direction of light changes or as the image is rotated or tilted.

15 It is an object of this invention to provide a more complex image having at least two distinct features wherein each feature is embodied in a separately applied coating.

It is an object of this invention to provide a more complex image having at least two distinct features wherein each feature is embodied in a
20 separate coating and wherein the at least two coatings provide the appearance of two images moving synergistically together yet appearing distinct from one another as the image is moved in one direction.

STATEMENT OF THE INVENTION

25 In accordance with an aspect of the invention there is provided, a method of coating an article comprising the steps of:

30 applying a first magnetic coating to a substrate using a magnetic field to orient flakes within the coating along magnetic field lines; and, after the first coating has cured, subsequently applying a second magnetic coating over the first coating and using a magnetic field to orient flakes within the second coating along magnetic field lines.

In accordance with an aspect of the invention there is further provided, a method of coating an article comprising the steps of:

applying a first magnetic coating to a substrate;

using a magnetic field to orient flakes within the coating in dependence upon the direction of the magnetic field lines; and,

5 after the first coating has cured, subsequently applying a second magnetic coating over the first coating and using a second magnetic field to orienting flakes within the second coating in dependence upon the second magnetic field; and allowing the second magnetic coating to cure.

10 In accordance with another aspect of the invention there is provided an image formed of magnetic particles aligned by a magnetic field, wherein two distinct features within the image appear to move simultaneously, and wherein the movement is relative movement, when the image is moved or when the light source upon the image is moved.

15 In accordance with another aspect of the invention there is provided an image formed of magnetic particles wherein two distinct features within the image appear to move, wherein one is stationary while the other moves, and vice versa, when the image is moved in two different directions or when the light source upon the image is moved in two different directions.

20 In a broad aspect of this invention, a method of providing an optically illusive image is provided comprising the steps of applying a pigment having magnetically alignable flakes therein over or under an already formed image, and magnetically aligning the magnetically alignable flakes within the pigment and allowing the flakes to cure.

25 It should be understood, from the above broad aspects of this invention that preferably magnetically alignable flakes are used, and a magnetic field is provided to align the magnetically alignable flakes; notwithstanding, other forces are fields that can align a plurality of flakes at a same time, in a predetermined orientation, are also within the scope of this application.

30 More broadly stated, this invention provides a method of forming an image by applying a first optical effect coating to a first side of the substrate and using a magnetic or electric field to orient flakes within the coating independence upon the field; and,

applying a second optical effect coating over the first coating or over the second side of the substrate, wherein effects of both coatings, or combined effects can be seen from at least one side of the substrate.

5 In an alternative embodiment of the invention first and second coatings include diffractive flakes, having a surface relief pattern formed therein or thereon, and flakes in the first coating are oriented along their surface relief pattern in a different orientation than diffractive flakes in the second coating.

BRIEF DESCRIPTION OF THE DRAWINGS

10 Exemplary embodiments of the invention will now be described in accordance with the drawings in which:

Fig. 1 is a drawing of a gemstone exhibiting austerism caused by small needles of rutile (titanium oxide) exhibiting six rays.

15 Figs. 2a through 2d depict the steps in the manufacture of an image having two crossed rolling bars that appear to move with a change of viewing angle.

Figs. 3a through 3d show a series of steps and images which form a final image in Fig. 3d wherein a globe having text therein provides a flip-flop optical effect.

20 Figs. 4a through 4d depict the steps in the manufacture of a flip-flop and a rolling bar created on a same substrate.

Figs. 5a through 5d illustrate the steps in several images of printing two rolling bars which appear to move closer together to form a single rolling bar and which upon tilting the image appear to separate into two rolling bars.

25 Figs 6a and 6b illustrate a container with the feature of the rolling bar of Fig. 5d.

Figs. 7a and 7b micrographs showing an area of an image obtained with a two steps printing process, wherein the two micrographs correspond to the same area of the image.

30 DETAILED DESCRIPTION

Orienting of magnetic flakes dispersed in a paint or an ink vehicle along lines of an applied magnetic field may produce a plurality of illusive

optical effects. Many of these effects, described in other patents and patent applications assigned to Flex Products Inc., have dynamic animation-like appearance similar to holographic kinograms or a tiger eye effect in gemstones. When a graphic image, printed on the surface of a substrate in the presence of a magnetic field, is tilted or bent with respect to the light source and to the viewer, the illusive optical effect moves toward or out of the viewer, or to the left or to the right.

However, in accordance with this invention it is possible to fabricate very different and more complex kinds of optical effects with two-stage printing or painting of an article with magnetic ink or paint containing magnetic particles, in the presence of different magnetic fields. In the first stage the clear or dyed ink or paint vehicle, mixed with reflecting or color-shifting or diffractive or any other platelet-like magnetic pigment of one concentration (preferably 15-50 weight %), is printed/painted on the surface of an article in any predetermined graphical pattern, exposed to the magnetic field to form a predetermined optical effect, and cured to fix magnetic flakes in the layer of solid ink/paint vehicle. In the second stage the ink or paint of lower concentration (preferably in the range of 0.1 -15wt.%) is printed on the top of the first printed image, exposed to the magnetic field, and cured. The ink or paint vehicle for the second layer is preferably clear, however may be dyed. Magnetic pigments for the second printed/painted layer can be the same as for the first layer or may be different. The pigment size for the second layer can be the same or different. The color of the pigment for the second layer can be the same as for the first layer or different. The shape and intensity of the field, applied to the second layer, can be the same or preferably may be different so that the viewer experiences two different effects. The graphical pattern for the second layer can be the same or different. Combination of inks or pigments colors may either enhance or depress a particular color in the final printed image.

Complex patterns of lines, points, arcs, and other shapes, enhanced with optically-illusive effects of current invention, can be utilized in printing

process to make visually encrypted documents difficult for counterfeiters to reproduce.

5 The substrate for the two-step printing in accordance with this invention can be transparent or opaque; this is generally determined by the graphics of the image and the desired optical effect. In the instance where an opaque substrate is utilized, the first and second applied coating layers are printed or painted on a same side of the opaque substrate with the more transparent image applied as the second coating over top of the first coating layer. For transparent substrates the application for the first and second 10 coatings can be as described for opaque substrates, or alternatively and preferably, the first coating layer can be printed with a concentrated ink on a first side of the substrate and the second coating layer can be printed with diluted ink on opposite side of the substrate. For some purposes, the first coating layer can be a printed layer with diluted ink and the layer with 15 concentrated ink can be printed second. Observation of a final image can be done through the substrate.

A first example of a printed article in accordance with an embodiment of this invention, with two crossing rolling bars produces an optical effect similar to asterism. United States patent application numbers 20 2004/0051297, and 2005/0106367 in the name of Raksha et al, describe a single rolling bar and a method for making a rolling bar, wherein the effect is formed by a cylindrical convex or concave reflection of light rays from magnetic particles dispersed in the ink or paint vehicle and aligned in the magnetic field.

25 Asterism in gemstones is caused by dense inclusions of tiny, parallel, slender fibers in the mineral which cause the light to reflect a billowy, star-like formation of concentrated light which moves around when the mineral is rotated. This is usually caused by small needles of rutile (titanium oxide) in the case of ruby and sapphire as exemplified in Fig. 1. The stars may exhibit 30 four, six, or more rays.

A flexographic printed image of a box with a four-ray star, or two rolling bars, is shown in Figs. 2c and 2d. The image in Fig. 2a of a single

rolling bar 202 is printed in a first step with ink containing 25wt. % of a green to gold color-shifting pigment on the surface of clear, translucent or opaque substrate and the convex rolling bar 202 is formed in applied magnetic field.

5 The second image shown in Fig. 2b is printed with an ink containing 10 wt. % of the same green to gold pigment dispersed in a clear ink vehicle (that makes it translucent) on the top of the first image 202 and the convex rolling bar 204 is formed in the field where its direction is at 90° to the direction of the rolling bar 202 in the first printed image of Fig. 2a. The resulting printed image of Fig. 2c shows four rays star. The star moves to the bottom of the printed image shown in Fig. 2d, when it is rotated or tilted horizontally with its upper edge away from the viewer, or up to the top of the image if it was tilted toward the viewer. By tilting the image back and forth in the direction shown in Fig. 2d, both rolling bars appear to simultaneously move toward and away from each other. By coating the substrate with two rolling bars in this manner, the functionality of each rolling bar of giving the perception of rolling across the sheet as it is rotated, is provided so that both bars appear to move synergistically, in apparently different directions by even a slight rotation in one direction. In this embodiment it is not necessary to move or tilt the sheet in two different directions to view both bars moving. A single movement in a single direction gives the perception of two bars moving differently.

25 Referring now to Fig. 3a, an image of a globe 301, shown was silk-screen printed with a thick 30 wt.% ink, containing magenta to gold color-shifting pigment with the particles averaged size of 22 microns, and exposed to magnetic field to form the V-shaped flip-flop optical effect. The flip-flop effect is described in United States patent applications 2004/0051297, and 2005/0106367, in the name of Raksha et al., incorporated herein by reference. In this effect the bottom half below the equator line of the globe has bright magenta color and the top side has dark gold color at normal angle of observation. Magnetic flakes in the bottom part of the image obtain such orientation in an applied magnetic field; these flakes send reflected light right into the eye of the observer, which makes them appear bright. In angle

contrast, the particles in the upper part of the globe send reflected light in the direction of observer's chest. The color of the flakes at this observation angle and this particular particles orientation is gold. When the globe, printed on the substrate, is tilted with its upper edge out of the observer the flakes in the bottom part reflect the light rays in the direction of the observer's hat that makes them dark gold. Simultaneously, the flakes in the upper part of the globe reflect the rays of incident light into the eye of the observer that visible as bright magenta. Tilt of the sample in the opposite direction swaps the colors of the image back.

The second image 302 "Test Text" shown in Fig. 3b is printed with diluted 10 wt. % ink on the top of the globe 301 and exposed to another magnetic field that produces a roof-shaped orientation of magnetic particles. An optical effect in the image, printed with these oriented particles, has a color "swap" opposite to the color changes of the first printed image. The pigment in the second ink is the same magenta to gold as in the first image but its size is close to 10 microns. The hue of this pigment has the same value as the larger 22 micron pigment but its chroma is lower than the chroma of larger pigment of the first layer that makes it slightly darker. At a normal angle of observation, the resulting image 303 in Fig. 3c shows translucent light magenta "Text" on a dark gold background and dark gold translucent "Test" on a bright magenta globe background. When the print 303 is tilted with its upper edge away from the observer, as shown in 304, two parts of the globe and the text interchange or "swap" their colors. The upper part of the globe becomes bright magenta with translucent dark gold TEXT and the bottom part of the globe becomes dark gold with bright magenta TEST.

The "Text Test" logo 401, shown in Fig.4a, was printed on the top of the image 402 containing a flip-flop feature described in the abovementioned patents. The image 402 was printed with a concentrated ink containing magnetic pigment Al/M/Al (where Al is aluminum. M is any magnetically alignable material). The flip flop can be formed with either V-shaped or roof-shaped alignment of magnetic flakes in the solid organic media. At normal

of observation and the V-shape alignment of the particles in the resin, the bottom part 403 of the image 402 is bright and the top part 404 is dark. A second image 405 was printed on the top of the image 402. In Fig. 4b the image 405 was printed with diluted ink, containing 5 wt.% of gold magnetic non-shifting pigment, and placed in the field to form a rolling bar optical feature. The rolling bar 406 is formed near top of the image. The ink was cured after completion of the particles alignment. The flip flop and the text are highly visible through the layer of the top coat in the double-printed image 407 at in Fig. 4d at normal angle of observation.

However, at the tilt of the printed image with its upper edge away from the observer, the rolling bar rolls down the printed image 407 and takes a place in the middle 408 of the box hiding the logo 401 and the flip flop as shown in Fig. 4a. An image 501, shown in Fig. 5a, was a flexo-printed on transparent substrate 500 with the ink containing 20 wt.% of magnetic pigment, placed in the field to form the convex rolling bar optical effect 502 and cured to fix aligned magnetic particles. Flexo printing or flexographic printing is a machine printing process that utilizes rollers or cylinders with a flexible rubber-like surface that prints with the raised area, much like surface printing, but with much less ink. In this process the ink dries quickly and allows the machine to run at high speed. The finished product has a very smooth finish with crisp detail and often resembles rotary screen printing.

In Fig. 5b another image 503 is printed with diluted ink, placed in the field to form the concave rolling bar 504 and cured to fix the particles in this position. The final print 505 shows at normal angle of observation an image with the single rolling bar effect 506. When the sample is tilted with its upper edge away from the observer the single rolling bar 506 splits in two rolling bars 507 and 508 moving in opposite direction. Reversed tilt of the image to the normal angle brings the rolling bars 507 and 508 together to make a single optical effect. Both printed images may have the same shape, as shown in Fig. 5d, or may have different shapes

Referring now to Figs. 6a and 6b a very attractive image for making of security labels on curved surfaces is shown. Pharmaceutical packaging

bottles, shown in Fig. 6a and 6b, are a good example of utilization of splitting rolling bars. The bottle 601 has a label 602 adhered to its surface. Security feature 603 with splitting rolling bar described in the previous example is printed on the top of the label 602. The feature 603 has a single rolling bar 604 at normal angle of observation. The bottle has a wide line 605 created by reflection of incident light from cylindrical surface of the bottle. However, the rolling bar 604, which also looks like a reflecting cylindrical surface, is at 90° to the line 605. Tilt of the bottle 601 with its top away from the observer causes a split of the rolling bar 604 in two rolling bars 606 and 607. When the bottle is tilted back, the rolling bars 606 and 607 collapse in the single rolling bar 604 again.

Turning now to Figs. 7a and 7b, micrograph 7a shows the groove orientation of the pigments of a first applied layer of diffractive particles in a carrier using a magnetic field oriented up-down (or vice versa). After the first printed layer was cured, a second print on top of the first was applied with a magnetic field oriented left to right (or vice versa). The camera used to capture the micrograph in Fig. 7b was focused to show the second groove orientation of the micro-structured particles. Notice that the loading of the second coating is lower than the loading of the first.

It should also be understood that in the subsequent figures and embodiments shown, groove oriented flakes can be used in place or along with the other types of flakes described heretofore.

Although the embodiments described heretofore, depict the two-step application of coatings to a same or different side of a substrate, less preferably, but still within the scope of this invention, is the use of a first alignable flake coating on a first substrate, laminated to a second substrate having a similar or different printed image or etched image thereon. For example in a first step a rolling bar can be printed on a first substrate, which can subsequently be laminated to a holographic image, wherein one of the substrates is substantially light transmissive.

In another less preferred embodiment of this invention two coatings are applied to different sides of a substrate, wherein a second of the coatings

5 has a viscosity which changes when energy such as light of a predetermined wavelength is applied and the coating become fluid; The first coating is a standard coating which can be magnetized and aligned after being applied. After the first coating cures and the flakes are permanently aligned, the second coating can be made fluid enough to align the flakes, and subsequently cured.

Of course numerous other embodiments of the invention may be envisaged, without departing from the spirit and scope of the invention.

What we claim is:

1. A method of coating an article comprising the steps of:
applying a first field orientable coating comprising flakes in an ink or
5 paint vehicle to a first side of a substrate and using a first magnetic or electric
field to orient the flakes within the first coating along field lines; after the
flakes within the first coating have been aligned, curing the first coating; and,
after the first coating has cured, subsequently applying a second magnetic
10 coating over the first coating or over a second side of the substrate under the
first coating and using a second magnetic or electric field to orient flakes
within the second coating along field lines, wherein configurations of the first
and second magnetic or electric fields are different from one another.
2. A method as defined in claim 1, wherein the magnetic field for
15 orienting the flakes within the first coating is a first magnetic field and wherein
the magnetic field used to orient flakes within the second coating is a second
magnetic field.
3. A method as defined in claim 1, wherein the magnetic or electric fields
20 are generated by different field generating systems.
4. A method as defined in claim 1 wherein a concentration of flakes in the
first coating is different from a concentration of flakes in the second coatings.
- 25 5. A method as defined in claim 4, wherein one of the first and second
coatings includes multilayer optically variable flakes and wherein the other of
the coatings includes diffractive flakes, wherein as at least some of the
diffractive flakes have a surface relief pattern formed therein.
- 30 6. A method as defined in claim 1, wherein the first and second coatings
include diffractive flakes, having a surface relief pattern formed therein or

thereon, and wherein flakes in the first coating are oriented along their surface relief pattern in a different orientation than diffractive flakes in the second coating.

- 5 7. A method as defined in claim 1, wherein the flakes within the second coating are oriented differently that the flakes of the first coating.
8. A method of creating an image comprising the steps of:
applying at a first coating over a first side of a substrate;
10 providing a first magnetic field to align particles within the first coating in a predetermined manner;
allowing the first coating to cure or dry; and,
applying a second coating over the first coating or over a second side of the substrate under the first coating and,
15 providing a second magnetic field before the second coating is cured or dried so as to align particles within the second coating, wherein configurations of the first and second magnetic or electric fields are different from one another.
- 20 9. A method of forming an image on a substrate comprising the steps of:
applying a first optical effect coating to a first side of the substrate and using a first magnetic or electric field to orient flakes within the coating in dependence upon the field; and,
applying a second optical effect coating over the first coating or over
25 the second side of the substrate under the first coating and using a second magnetic or electric field to orient flakes within the coating in dependence upon the field, wherein configurations of the first and second magnetic or electric fields are different from one another, and wherein effects of both coatings, or combined effects can be seen from at least one side of the
30 substrate.

Fig. 1

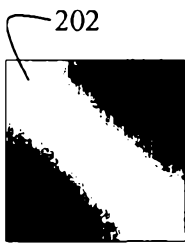

Fig. 2a

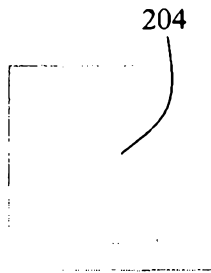

Fig. 2b

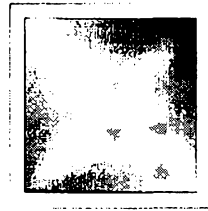

Fig. 2c

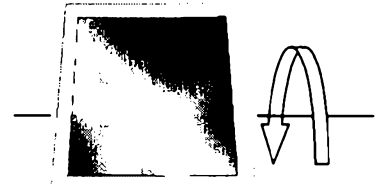

Fig. 2d

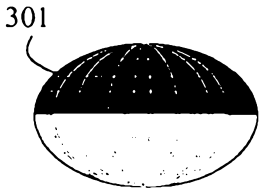

Fig. 3a



Fig. 3b

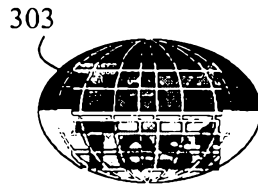

Fig. 3c



Fig. 3d

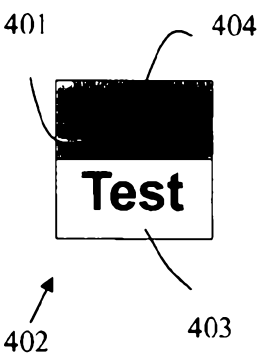

Fig. 4a



Fig. 4b

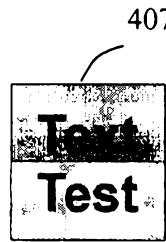

Fig. 4c

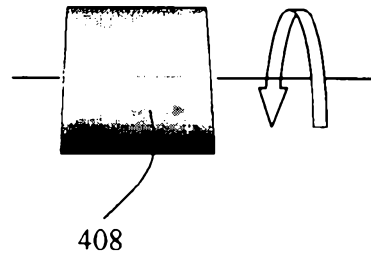

Fig. 4d

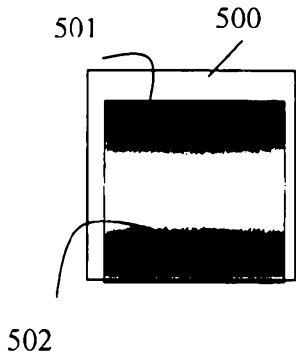

Fig. 5a

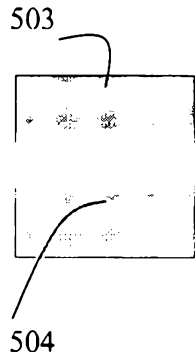

Fig. 5b



Fig. 5c

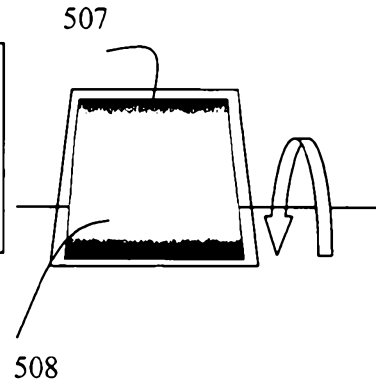

Fig. 5d

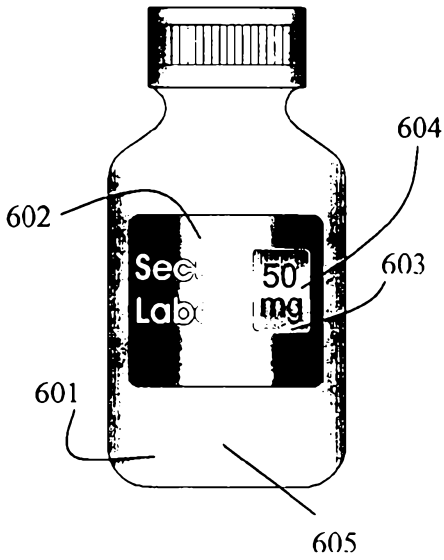

Fig. 6a

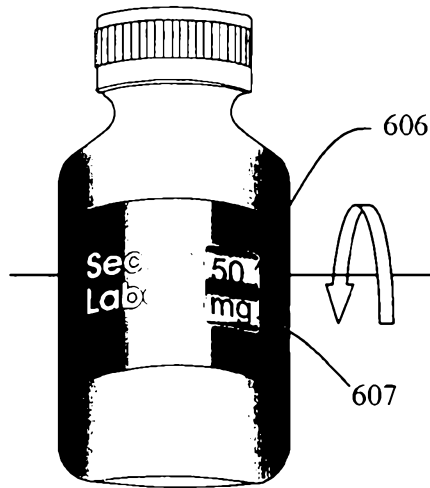

Fig. 6b

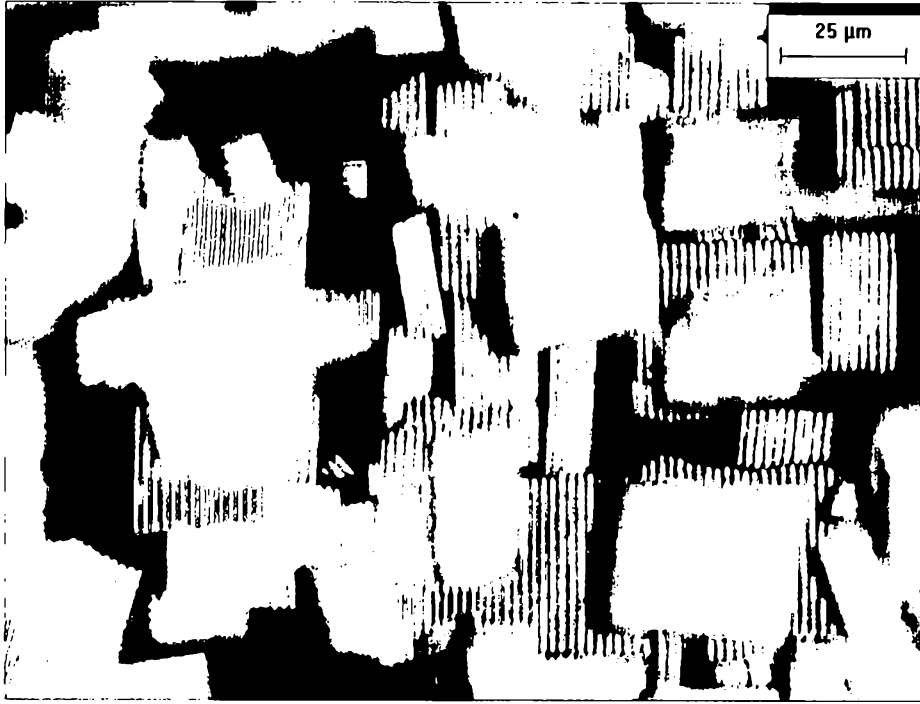

FIG. 7a

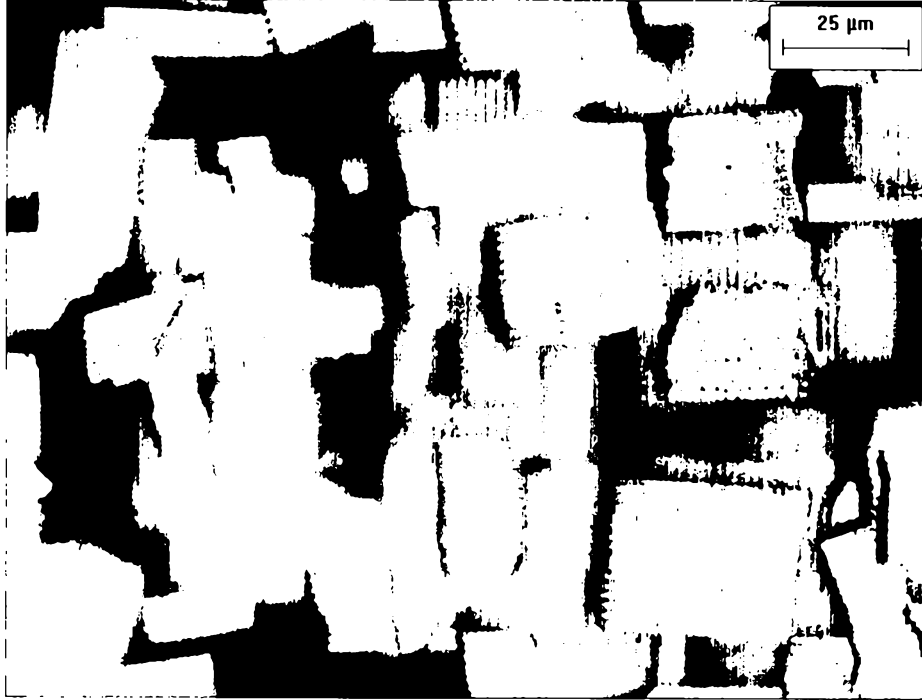

FIG. 7b