

(19) **DANMARK**

(10) **DK/EP 4354482 T3**



Patent- og
Varemærkestyrelsen

(12) **Oversættelse af
europæisk patentskrift**

-
- (51) Int.Cl.: **H 01 H 23/20 (2006.01)** **H 01 H 13/20 (2006.01)**
- (45) Oversættelsen bekendtgjort den: **2025-03-10**
- (80) Dato for Den Europæiske Patentmyndigheds bekendtgørelse om meddelelse af patentet: **2024-12-04**
- (86) Europæisk ansøgning nr.: **22382955.7**
- (86) Europæisk indleveringsdag: **2022-10-10**
- (87) Den europæiske ansøgnings publiceringsdag: **2024-04-17**
- (84) Designerede stater: **AL AT BE BG CH CY CZ DE DK EE ES FI FR GB GR HR HU IE IS IT LI LT LU LV MC ME MK MT NL NO PL PT RO RS SE SI SK SM TR**
- (73) Patenthaver: **Schneider Electric Espana, S.A., Bac de Roda, 52, Edificio A, 08019 Barcelona, Spanien**
- (72) Opfinder: **REBOLÉ OLLETA, José Antonio, , 31100 PUENTE LA REINA (NAVARRA), Spanien**
SANTESTEBAN INSAUSTI, Patxi, , 31100 Puente la Reina (Navarra), Spanien
GONZÁLEZ IRIBAS, Aitor, , 31100 Puente la Reina (Navarra), Spanien
- (74) Fuldmægtig i Danmark: **Patrade A/S, Ceresbyen 75, 6., 8000 Århus C, Danmark**
- (54) Benævnelse: **KONVERTIBEL ELEKTRISK KONTAKT**
- (56) Fremdragne publikationer:
EP-A1- 2 924 702
CZ-B6- 294 989
KR-B1- 101 511 322

DESCRIPTION

Description

Technical field

[0001] The present invention relates to electrical switches or commutators, and more specifically to those comprising an actuating rocker assembled on the base body of the switch which can be actuated between two stable connection and disconnection positions, being convertible into a push-button type switch with a single stable position by means of the action of a spring.

State of the art

[0002] Solutions consisting of an electrical switch or commutator with two stable positions which is convertible to a push-button with a single stable position by means of the action of a spring using various solutions are known. According to the current regulation for switches, a push-button is understood to be momentary switches, wherein electrical connection takes place while actuation is taking place and returns to the disconnection position when the actuation ends. Furthermore, said momentary switches can be normally open or normally closed.

[0003] European Patent document EP2924702 discloses a switch of this type, in which the rocker has a hollow head in which a force transmission element is fitted, such that when the transmission element is coupled, the spring is activated so that the rocker acts like a push-button, and when the transmission element is uncoupled, it works as an ON-OFF switch with two opposed stable positions.

[0004] However, this solution has a number of drawbacks such as the fact that the connection of the force transmission element is performed by pressure, for example, by clipping, such that it hinders activation by the user who must apply force to snap-fit the pressure element into the hollow head of the rocker, where correct coupling may not be established if insufficient force is applied, or the part making up the transmission element may break when force is applied with too much pressure. Furthermore, if it is configured so that the pressure to be exerted is very small, the force of the spring may cause the uncoupling of the clipping between the head of the rocker and the force transmission element.

[0005] Another problem arises at the time of uncoupling in order to bring the rocker from a

push-button function back to the two stable-position function. In this case, it is necessary to use a tool to eliminate the clipping force, but the access for disconnection makes the uncoupling manoeuvre difficult, where breakage of one of the coupleable elements may once again occur, rendering it unusable for the push-button function. Furthermore, in the inactive position, said part making up the transmission element must remain adhered to the rocker so that it is not misplaced, which means establishing a pivot point that is susceptible to breakage or failure. Another possible malfunction is that, with the sudden actuation of the switch, the fixing created as a clip which is activated and deactivated may become disengaged, losing the push-button effect and requiring reactivation by disassembling at least the aesthetic part of the switch.

[0006] In view of the described drawbacks or limitations of the solutions existing today, a simple and safe solution which allows the activation and deactivation of the spring establishing the conversion of a switch with two stable positions to a push-button with only one stable position is required.

Object of the invention

[0007] In order to achieve this objective and solve the technical problems described up until now, in addition to providing additional advantages that can be derived subsequently, the present invention provides a convertible electrical switch with an actuating rocker assembled on a base of a switch body such that it can swivel between two stable switch connection and disconnection positions, and with an actuating element connectable to the actuating rocker pushing the actuating rocker to a single stable position, when the activation element and the rocker are connected in an activation position, by means of the action of a spring coupled to the activation element, converting the switch into a push-button. Switch in which the activation element is arranged such that it is slidingly assembled in a guided manner through a window of the actuating rocker with a geometry in correspondence with the external geometry of the activation element such that in the inactive position the activation element goes through the window without pushing the rocker, whereas in the activation position the activation element is configured to push the rocker by means of at least one projection after establishing a rotation of said activation element, such that the projection contacts the rocker, being moved together with the activation element by means of the action of the spring without both elements being attached. The force of the spring pushes the activation element which, by means of a rectilinear movement in the actuation direction of the spring, in turn pushes the rocker along its curvilinear movement, with there being a relative movement between the rocker and the activation element throughout of the movement.

[0008] As a result of this configuration, the activation element remains freely assembled inside the switch without having to be coupled to any part of the switch, but is positioned inside the switch with a freedom of movement (in the actuation direction of the spring) established by the guidance provided by the window of the rocker, thus eliminating couplings or attachments that are susceptible to breakage or malfunction.

[0009] Additionally, the activation of the spring for converting the switch to a push-button is facilitated, given that simply by rotating the activation element, it is possible to connect the activation element with the rocker and push the rocker with the force of the spring, as a result of the contact of the protrusion of the activation element. In this case, it is not necessary to adjust the force of the spring for the coupling, since the rotation ensures contact between the rocker and the activation element without the risk of their attachment, resulting from the push of the spring, being disconnected. Likewise, transition to the inactive position is facilitated simply by rotating in the opposite direction to the initial inactive position in which the spring does not exert any force on the rocker.

[0010] Preferably, the geometry of the activation element will be cylindrical, this configuration being the optimal configuration for establishing activation by rotation.

[0011] According to a feature of the invention, the convertible electrical switch comprises a bowl-shaped opening which establishes an inner guidance with respect to a shaft projecting from the base by means of the sliding between respective surfaces. Therefore, the activation element, in addition to being guided externally by the window of the rocker, is internally guided by the shaft projecting from the base to be inserted into the activation element.

[0012] In this way, the activation element remains slidably assembled inside the switch, with the movement thereof being allowed only in the direction of the force of the spring, without the need to be fixed to any element of the switch, therefore avoiding a coupling that is susceptible to breakage, and providing more robustness in the assembly.

[0013] According to another feature of the invention, the spring sits in contact with the base shaft along same. This configuration retains the spring between the base and the activation element, preventing it from coming out of its seat, and ensuring that the force of the spring effort is applied in only one direction.

[0014] According to another feature of the invention, the activation element comprises in the opening an activation element shaft on which the spring sits in contact with said activation element shaft along same. This configuration more effectively secures the spring in its seat, preventing it from moving laterally, and ensuring that the force is applied only in one activation direction.

[0015] In order to more precisely ensure that the actuating element moves only in the actuation direction of the spring and to prevent possible buckling of its lower part (the part closest to the base of the switch), it is envisaged for the base to comprise a groove configured for guiding the activation element. This groove comprises a geometry in correspondence with the geometry of the activation element, preferably cylindrical, such that there is established an annular groove in which the lower part of the actuation element penetrates, being guided in the lower portion on its outer surface by the wall of said groove, and internally by the base shaft.

[0016] Preferably, the activation element comprises on its periphery at least one flange

complementary to at least one clipping tooth of the base configured for establishing a movement stop for stopping the movement of the activation element once the clipped assembly of the activation element in the base has been established.

[0017] In this way, the activation element, in addition to being retained by the established guide or guides, comprises a movement stop which prevents it from coming out of its housing.

[0018] Said flange can be a continuous perimeter rib such that said stop acts during the rotation of the activation element.

[0019] According to another aspect of the invention, the activation element comprises at least one stop rib which determines a rotation stop for the activation element up to the activation position upon contacting the clipping tooth of the base. In this way it is ensured that the active position has been reached, and the activation element correctly pushes the rocker.

[0020] This rib can also serve as an indicator so that the angular position of the activation element can be identified by viewing said rib.

[0021] As a system to ensure that the rotating element inadvertently returns to the inactive position, it is envisaged for the actuating rocker to comprise a retaining recess configured for the fitting of the projection of the activation element in the activation position. Simply by the force of the spring upon reaching the activation position, the projection of the activation element will move up until it fits into the recess in the rocker.

[0022] According to a final aspect of the invention, the activation element comprises an activation groove accessible through the window of the actuating rocker by means of a tool such as a screwdriver, which makes it easier to access the activation element and to establish the necessary rotation.

Description of the figures

[0023]

Figure 1 shows a schematic exploded perspective view of an embodiment of the switch object of the invention.

Figure 2 shows a cross-section view of the switch object of the invention assembled with the activation element in the inactive position.

Figure 3 shows a cross-section view of the switch object of the invention assembled with the activation element in the active position.

Figure 4 shows a top view of the switch object of the invention with the activation element in the inactive position.

Figure 5 shows a top view of the switch object of the invention with the activation element in the active position.

Figure 6 shows a longitudinal section view of the switch object of the invention in which the recess of the rocker and the protrusion of the activation element fitted in said recess can be seen.

Figure 7 shows a perspective view of the switch object of the invention assembled, and in the active position, in which a rib of the activation element can be seen abutting against a clipping tooth of the base.

Figure 8 shows a cross-section view of an alternative embodiment of the switch object of the invention.

Detailed description of the invention

[0024] In view of the mentioned figures and according to the numbering used, a preferred nonlimiting embodiment of the invention comprising the parts and elements indicated and described in detail below can be seen therein.

[0025] As can be seen in the practical embodiment of Figure 1, the switch comprises a body (5) with a base (2) on which the actuating rocker (1) is assembled such that it can swivel between two stable switch connection and disconnection positions, with a decorative plate (6) which facilitates activation by a user being assembled on said rocker (1).

[0026] Therefore, the object of the invention is to convert the switch with two stable positions into a switch with a push-button function which, by means of the action of a spring (4), urges the rocker (1) to a single momentary stable position as long as the actuation on the plate (6) is maintained.

[0027] To that end, the switch comprises an activation element (3) which is arranged such that it is slidingly assembled in a guided manner between the rocker (1) and the base (2), and serves as a seat for a spring (4) which performs a pushing function so as to convert the switch with two stable positions into a push-button.

[0028] As can be seen in the figures, the rocker (1) comprises a window (1.1) the geometry of which corresponds with the geometry of the activation element (3) which, in the inactive state, as can be seen in Figures 2 and 4, the activation element (3) is free without interfering with the rocker (1) when it is pressed, such that the activation element (3) remains stationary and goes through the window (1.1) of the rocker (1), with the spring (4) remaining in its extended position. Preferably, the activation element (3) is in the shape of a cylinder.

[0029] To convert the switch into a push-button, as can be seen in Figures 1 and 3, the activation element (3) preferably comprises two projections (3.1) arranged preferably in diametrically opposite positions, such that when a manual rotation of said activation element (3) is established by the user, as can be seen in Figure 3, the activation element (3), by means of the action of the spring (4), connects with the rocker (1) in an activation position. Therefore, the activation element (3) moves together with the rocker (1) without both elements being attached, pushing same with the projections (3.1) by means of the action of the spring (4), such that in said activation position the rocker (1) is always urged to a single stable position, being converted into a push-button. Figure 5 shows how the projections (3.1) no longer coincide with the geometry of the window (1.1) as they are in contact with the rocker (1).

[0030] In order for the movement to be performed accurately in the activation position, the base (2) comprises a base shaft (2.1) projecting from said base (2) such that it is inserted into an inner bowl-shaped opening (3.2) of the activation element (3). Like the opening (3.2) of the activation element (3), the shaft (2.1) preferably has a cylindrical configuration such that an inner sliding guidance is established between both elements which, together with the sliding guidance between the outer surface of the activation element (3) and the window (1.1) of the rocker, ensures the positioning of the activation element (3) such that it is slidingly assembled inside the switch. As can be seen in the practical embodiment of Figures 1 to 7, this inner guidance is established between the outer surface of the base shaft (2.1) and the inner surface of the opening (3.2) of the activation element.

[0031] This guidance limits the movement of the activation element (3) to the actuation direction of the spring (4) which, in the practical embodiment of Figures 1 to 7, has a first end (4.1) which is coupled to an activation element shaft (3.3) of the opening (3.2) of the activation element (3), with the spring being kept in contact at said first end (4.1) with the activation element shaft along same. With a second end (4.2) of the spring (4) that sits in contact with an inner channel (2.1.1) of the shaft (2.1) of the base (2). Preferably, the inner diameter of the inner channel (2.1.1) will be the same diameter as the spring (4), allowing a sliding adjustment which prevents it from coming out of its housing and acting only in one activation direction.

[0032] As can be seen in Figures 2 and 3, the spring (4) will only remain under compression in its activation position before bringing the rocker to the stable position, such that the service life of the switch is prolonged by not maintaining the spring (4) in its forced compression position.

[0033] To ensure a more accurate positioning of the activation element (3) in its sliding assembly, it is envisaged for the base (2) to comprise an annular groove (2.2) which, as seen in Figures 1 to 3, surrounds the shaft (2.1) of the base (2). This groove (2.2) allows the activation element (3) to be inserted therein and to not come out of its path in the actuation direction of the spring (4) when the activation element is in the activation position, being guided internally by the shaft (2.1) of the base (2) and externally by the walls of the groove (2.2), since in this position it does not have the guidance of the window (1.1) of the rocker (1).

[0034] According to another feature of the invention, as can be seen in Figures 1 to 3, the

activation element (3) comprises on its periphery at least one flange (3.4), preferably two flanges (3.4) facing one another (not shown), and even more preferably a flange (3.4) in the form of a continuous perimeter rib (Figure 7) which, in a manner complementary to at least one clipping tooth (2.3) of the base (2), and preferably two clipping teeth (2.3) facing one another in diametrically opposite positions, establishes a clipped assembly of the activation element (3) which defines a movement stop for stopping the movement of the activation element in the actuation direction of the spring. This configuration prevents it from coming out of its housing. Preferably, said clipping teeth (2.3) are formed by respective legs projecting from the base (2).

[0035] The activation element (3) transitions to its activation position once the projections (3.1) have rotated sufficiently so as to deviate from the geometry of the window (1.1), however, in order to establish a safe rotation stop in which the activation element (3) is prevented from coming out of its activation position, it is envisaged for said activation element (3) to comprise a stop rib (3.5). Said stop rib (3.5) is arranged on the outer surface of the activation element (3) such that it establishes rotation stop upon contacting the clipping tooth (2.3) of the base (2). This stop rib (3.5) can also serve as a guide for the user by way of an indicator so that the positioning of the activation element (3) can be determined.

[0036] Although a safety angular rotation is established, the case where said rotation is inadvertently reversed, with the push-button function being eliminated, may arise. To avoid this problem, it is envisaged for the rocker (1) to comprise at least one retaining recess (1.2) configured for the projection (3.1) of the activation element (3) to fit therein when the maximum safety rotation has been established, with the projection (3.1) of the activation element being inserted into the recess (1.2) by means of the action of the spring force (Figure 6).

[0037] Additionally, to facilitate the transition of the activation element (3) to its activation position, the activation element (3) comprises an activation groove (3.6) preferably in the form of a crossarm, such that it is accessible through the window (1.1) of the actuating rocker (1) so that the activation element (3) can be easily rotated by means of a tool such as a screwdriver. Furthermore, in the case of having the retaining recess (1.2), it will be necessary to apply an initial pressure so that the activation element (3) comes out of the retaining recess (1.2) and then apply rotation to move the activation element (3) to its inactive position, in order to transition from the push-button function to that of a switch with two stable positions.

[0038] According to the alternative embodiment of Figure 8, the inner guidance for guiding the activation element with respect to the base shaft (2.1) is established between the inner surface of the inner channel (2.1.1) of the base shaft (2.1) and the outer surface of the activation element shaft (3.3). In this case, the spring (4) has a first end (4.1) that sits in contact with the inner surface of the opening (3.2) of the activation element (3) along same, and a second end (4.2) of the spring (4) that sits in contact with the outer surface of the base shaft (2.1) along same.

[0039] A safe and reliable convertible switch with characteristics that guarantee a longer

service life than known solutions is thereby provided.

REFERENCES CITED IN THE DESCRIPTION

Cited references

This list of references cited by the applicant is for the reader's convenience only. It does not form part of the European patent document. Even though great care has been taken in compiling the references, errors or omissions cannot be excluded and the EPO disclaims all liability in this regard.

Patent documents cited in the description

- EP2924702A [0003]

Patentkrav

1. En konvertibel elektrisk kontakt med en aktiveringsvippe (1), der er monteret på en base (2) af en krop (5) af kontakten, således at den kan dreje mellem to stabile kontaktilslutnings- og frakoblingspositioner, og med et aktiveringselement (3), der kan forbindes med aktiveringsvippen (1), der skubber aktiveringsvippen (1) til en enkelt stabil position, når aktiveringselementet (3) og vippen (1) er forbundet i en aktiveringsposition ved hjælp af virkningen af en fjeder (4), der er koblet til aktiveringselementet (3), der omdanner kontakten til en trykknop, kendetegnet ved, at aktiveringselementet er anbragt således, at det glidende samles på en kontrolleret måde gennem et vindue (1.1) i aktiveringsvippen (1) med en geometri i overensstemmelse med den eksterne geometri af aktiveringselementet (3), således at aktiveringselementet (3) i den inaktive position går gennem vinduet uden at skubbe til vippen (1), mens aktiveringselementet (3) i aktiveringspositionen er konfigureret til at skubbe til vippen (1) ved hjælp af mindst et fremspring (3.1) efter at have etableret en rotation af nævnte aktiveringselement (3), således at fremspringet (3.1) kommer i kontakt med vippen (1) og bevæges sammen med aktiveringselementet (3) ved hjælp af fjederens (4) virkning.
2. Den konvertible elektriske kontakt ifølge det foregående krav, hvori aktiveringselementet (3) omfatter en skålformet åbning (3.2), der etablerer en indre styring i forhold til en basisaksel (2.1), der stikker ud fra basen (2) ved hjælp af glidningen mellem respektive overflader.
3. Den konvertible elektriske kontakt ifølge et hvilket som helst af de foregående krav, hvori fjederen (4) sidder i kontakt med basisakslen (2.1) langs samme.
4. Den konvertible elektriske kontakt ifølge et hvilket som helst af de foregående krav, hvori aktiveringselementet (3) i åbningen (3.2) omfatter en aktiveringselementaksel (3.3), hvorpå fjederen (4) sidder i kontakt med nævnte aktiveringselementaksel (3.3) langs samme.
5. Den konvertible elektriske kontakt ifølge et hvilket som helst af de foregående krav, hvori basen (2) omfatter en fordybning (2.2) med en geometri i overensstemmelse med geometrien af aktiveringselementet (3), der er konfigureret til at styre aktiveringselementet (3).

6. Den konvertible elektriske kontakt ifølge et hvilket som helst af de foregående krav, hvori aktiveringselementet (3) på sin periferi omfatter mindst en flange (3.4), der er komplementær til mindst en holdetap (2.3) på basen (2), der er konfigureret til at etablere et bevægelsesstop til at stoppe bevægelsen af aktiveringselementet (3), når den sammenhæftede samling er blevet etableret.
5
7. Den konvertible elektriske kontakt ifølge det foregående krav, hvori aktiveringselementet (3) omfatter mindst en stopribbe (3.5), der bestemmer et rotationsstop for aktiveringselementet (3) op til aktiveringspositionen ved kontakt med holdetappen (2.3) på basen (2).
10
8. Den konvertible elektriske kontakt ifølge et hvilket som helst af de foregående krav, hvori aktiveringsvippen (1) omfatter en fastholdelsesudsparring (1.2), der er konfigureret til montering af fremspringet (3.1) af aktiveringselementet (3) i aktiveringspositionen, hvilket forhindrer rotation af aktiveringselementet (3).
15
9. Den konvertible elektriske kontakt ifølge et hvilket som helst af de foregående krav, hvori aktiveringselementet (3) omfatter en aktiveringsfordybning (3.6), der er tilgængelig gennem vinduet (1.1) i aktiveringsvippen (1) ved hjælp af et værktøj såsom en skruetrækker.
20

DRAWINGS

Drawing

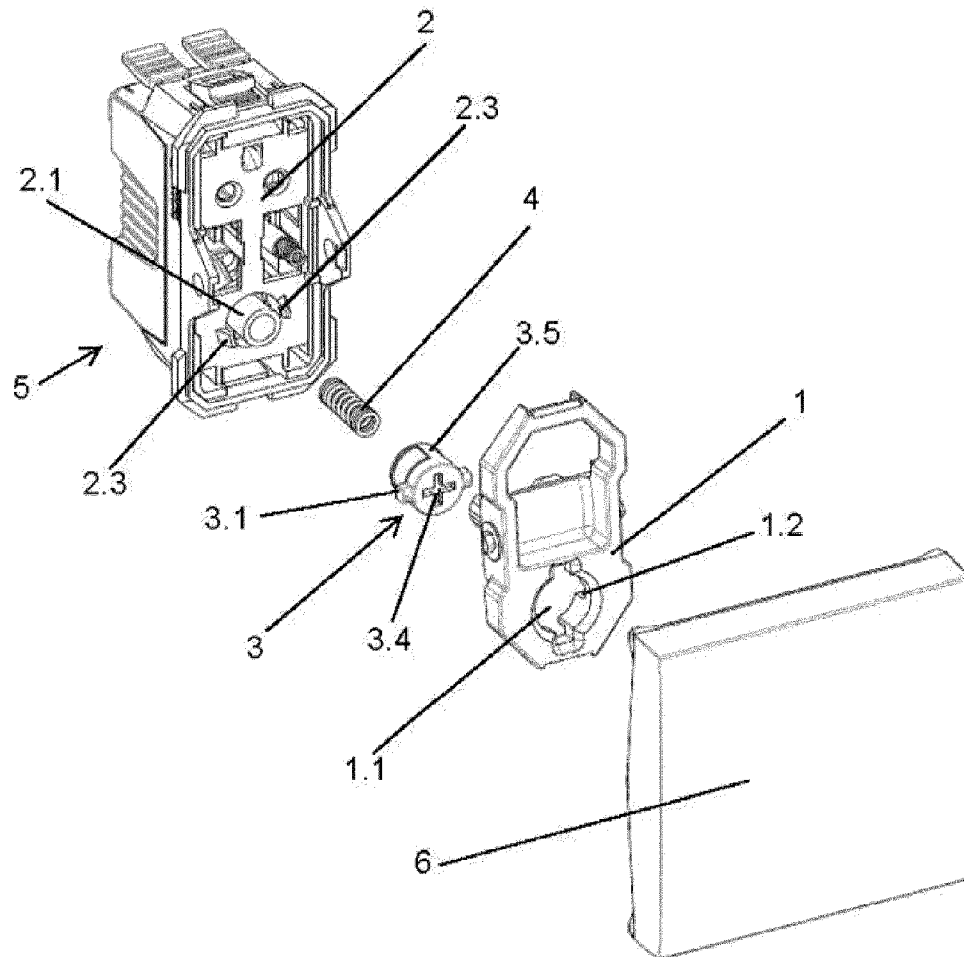

FIG. 1

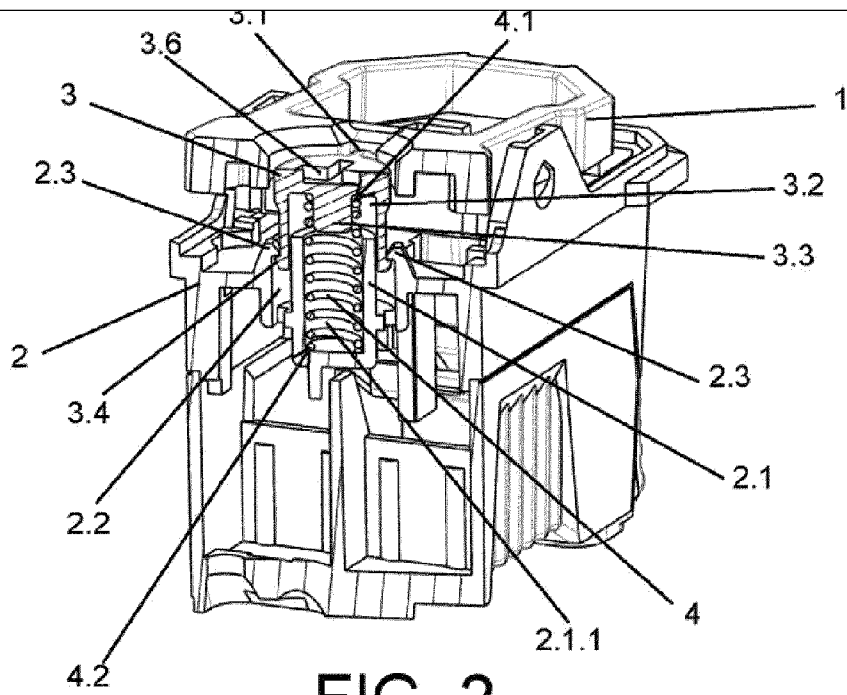

FIG. 2

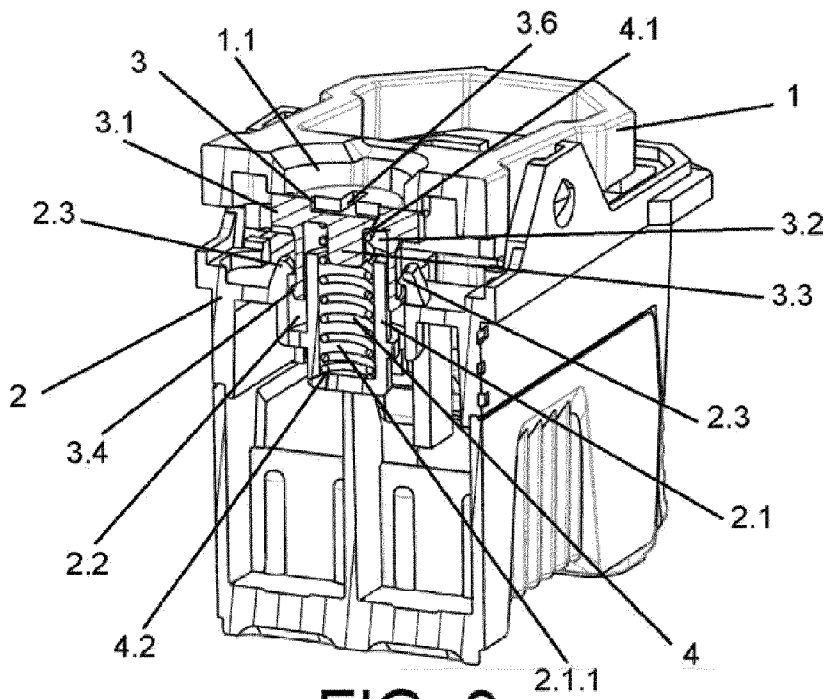

FIG. 3

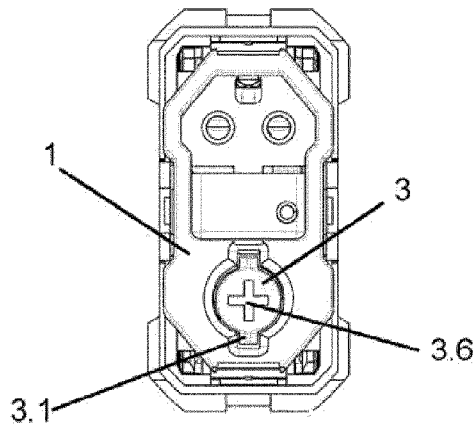

FIG. 4

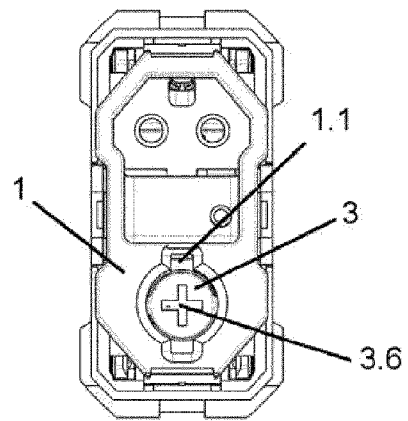

FIG. 5

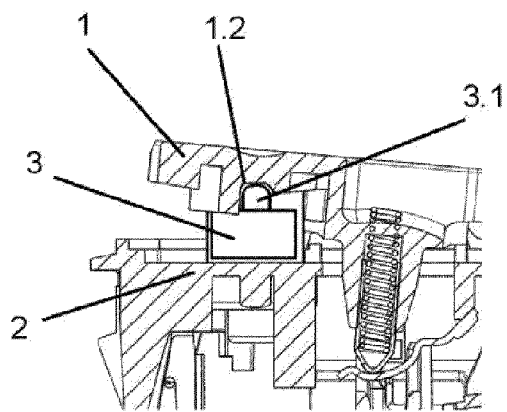

FIG. 6

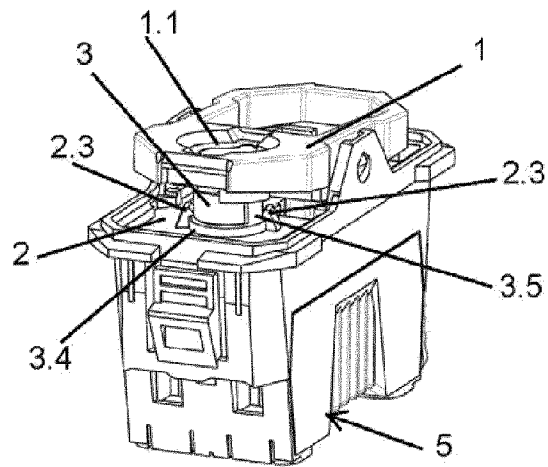

FIG. 7

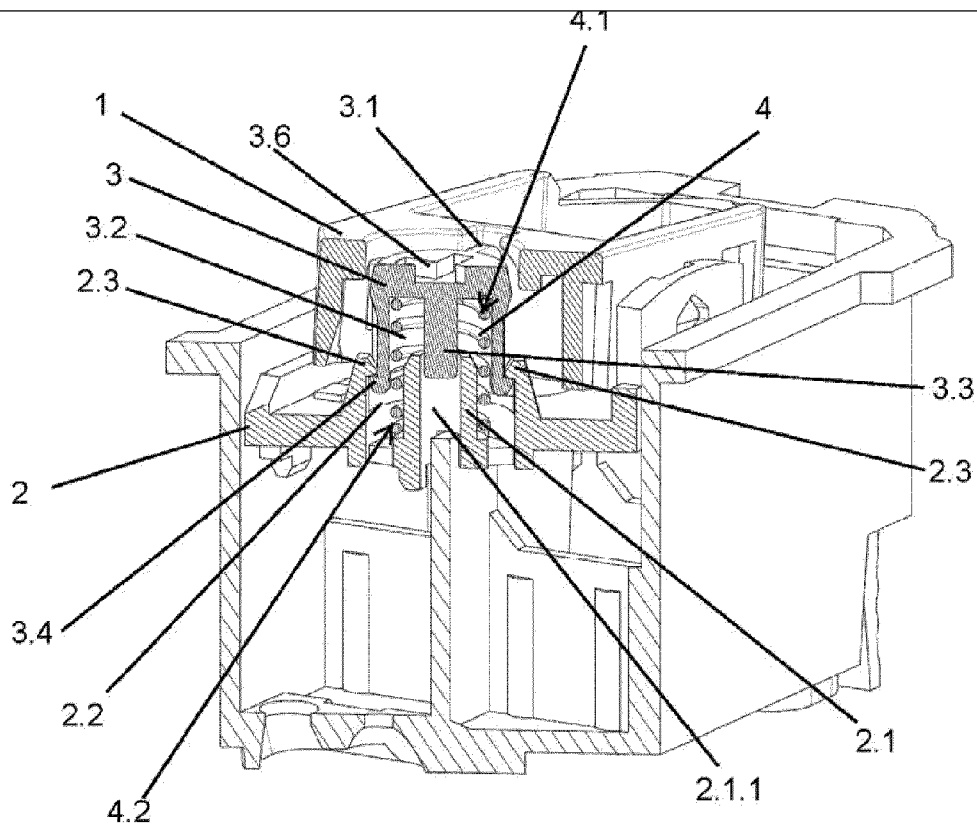

FIG. 8