



## INTERNATIONAL APPLICATION PUBLISHED UNDER THE PATENT COOPERATION TREATY (PCT)

(51) International Patent Classification <sup>6</sup> : <b>C05F 17/02</b>	<b>A1</b>	(11) International Publication Number: <b>WO 00/02832</b> (43) International Publication Date: 20 January 2000 (20.01.00)
<p>(21) International Application Number: PCT/SE99/01069</p> <p>(22) International Filing Date: 16 June 1999 (16.06.99)</p> <p>(30) Priority Data: 9802501-8      10 July 1998 (10.07.98)      SE</p> <p>(71) Applicant (for all designated States except US): INTERNATIONAL COMPOST DEVELOPMENT AB [SE/SE]; Forskningsbyn Ideon, S-223 70 Lund (SE).</p> <p>(72) Inventors; and (75) Inventors/Applicants (for US only): FRANZÉN, Bo [SE/FR]; 1, quai aux Fleurs, F-75004 Paris (FR). FRANSÉN, Claes, B. [SE/FR]; B.P. 11, F-78610 Saint Léger en Yvelines (FR). BLOMSTERGREN, Bertil [SE/SE]; Annebergsgatan 15A, S-214 66 Malmö (SE).</p> <p>(74) Agents: STRÖM, Tore et al.; Ström &amp; Gulliksson AB, P.O. Box 4188, S-203 13 Malmö (SE).</p>	<p>(81) Designated States: AL, AM, AT, AU, AZ, BA, BB, BG, BR, BY, CA, CH, CN, CU, CZ, DE, DK, EE, ES, FI, GB, GD, GE, GH, GM, HR, HU, ID, IL, IN, IS, JP, KE, KG, KP, KR, KZ, LC, LK, LR, LS, LT, LU, LV, MD, MG, MK, MN, MW, MX, NO, NZ, PL, PT, RO, RU, SD, SE, SG, SI, SK, SL, TJ, TM, TR, TT, UA, UG, US, UZ, VN, YU, ZW, ARIPO patent (GH, GM, KE, LS, MW, SD, SL, SZ, UG, ZW), Eurasian patent (AM, AZ, BY, KG, KZ, MD, RU, TJ, TM), European patent (AT, BE, CH, CY, DE, DK, ES, FI, FR, GB, GR, IE, IT, LU, MC, NL, PT, SE), OAPI patent (BF, BJ, CF, CG, CI, CM, GA, GN, GW, ML, MR, NE, SN, TD, TG).</p> <p><b>Published</b> <i>With international search report.</i> <i>Before the expiration of the time limit for amending the claims and to be republished in the event of the receipt of amendments.</i></p>	

(54) Title: METHOD AND MACHINE FOR DECOMPOSING ORGANIC WASTE

## (57) Abstract

Method and machine for decomposing compostable waste wherein the waste is shredded and the shredded waste is supplied to a space in a vessel (10) at the bottom (13) thereof. The waste is agitated and mixed by wings (22-27) on a rotating agitator (16, 22-27) in the vessel while being lifted to the top thereof. Air is supplied to the vessel through nozzles (30) provided on one or more wings (22) located in the lower region of the vessel while maintaining a negative pressure in the vessel. Decomposed waste is discharged from the vessel through a discharge pipe (68) at the top thereof.

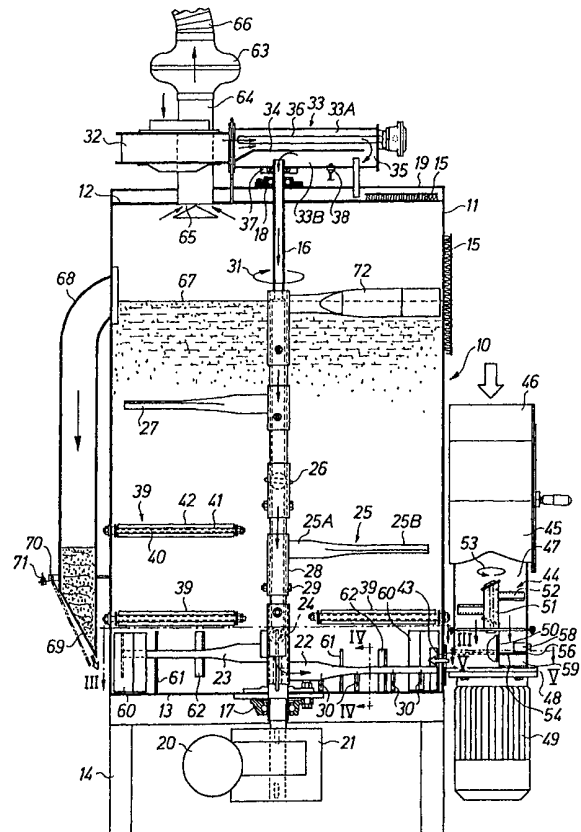

**FOR THE PURPOSES OF INFORMATION ONLY**

Codes used to identify States party to the PCT on the front pages of pamphlets publishing international applications under the PCT.

AL	Albania	ES	Spain	LS	Lesotho	SI	Slovenia
AM	Armenia	FI	Finland	LT	Lithuania	SK	Slovakia
AT	Austria	FR	France	LU	Luxembourg	SN	Senegal
AU	Australia	GA	Gabon	LV	Latvia	SZ	Swaziland
AZ	Azerbaijan	GB	United Kingdom	MC	Monaco	TD	Chad
BA	Bosnia and Herzegovina	GE	Georgia	MD	Republic of Moldova	TG	Togo
BB	Barbados	GH	Ghana	MG	Madagascar	TJ	Tajikistan
BE	Belgium	GN	Guinea	MK	The former Yugoslav Republic of Macedonia	TM	Turkmenistan
BF	Burkina Faso	GR	Greece			TR	Turkey
BG	Bulgaria	HU	Hungary	ML	Mali	TT	Trinidad and Tobago
BJ	Benin	IE	Ireland	MN	Mongolia	UA	Ukraine
BR	Brazil	IL	Israel	MR	Mauritania	UG	Uganda
BY	Belarus	IS	Iceland	MW	Malawi	US	United States of America
CA	Canada	IT	Italy	MX	Mexico	UZ	Uzbekistan
CF	Central African Republic	JP	Japan	NE	Niger	VN	Viet Nam
CG	Congo	KE	Kenya	NL	Netherlands	YU	Yugoslavia
CH	Switzerland	KG	Kyrgyzstan	NO	Norway	ZW	Zimbabwe
CI	Côte d'Ivoire	KP	Democratic People's Republic of Korea	NZ	New Zealand		
CM	Cameroon			PL	Poland		
CN	China	KR	Republic of Korea	PT	Portugal		
CU	Cuba	KZ	Kazakistan	RO	Romania		
CZ	Czech Republic	LC	Saint Lucia	RU	Russian Federation		
DE	Germany	LI	Liechtenstein	SD	Sudan		
DK	Denmark	LK	Sri Lanka	SE	Sweden		
EE	Estonia	LR	Liberia	SG	Singapore		

5 Title of the invention: **Method and machine for  
decomposing organic waste**

The invention relates to method and machine for  
decomposing organic waste of the kind disclosed in WO  
10 97/46499.

In the method the organic waste is shredded and the  
shredded waste is supplied to a space at the bottom  
thereof, the waste is agitated and mixed in said space  
while being lifted to the top thereof, air is passed  
15 through the waste in said space, and decomposed waste is  
discharged from said space at the top thereof.

The composting machine for working the method  
comprises a vessel, a waste inlet at the bottom of the  
vessel, means for shredding waste supplied to the inlet, an  
20 agitator in the vessel, comprising a rotatable vertical  
shaft in the centre of the vessel and wings projecting  
radially from the shaft to agitate and mix the waste  
supplied to the vessel through the inlet at least one of  
said blades being skewed or bevelled to lift the waste in  
25 the vessel and thus move the waste from the bottom of the  
vessel to the top thereof, an air intake allowing air flow  
into the vessel in the lower region thereof, a discharge  
pipe for decomposed waste at the top of the vessel, and  
means providing a flow of air from the air intake through  
30 the vessel and the waste therein to the surroundings  
through the air outlet.

The main object of the invention is to render the  
decay or decomposition of the composted organic waste more  
efficient by securing a thorough mixing and agitation of  
35 the waste as well as dewatering thereof while avoiding  
clodding of the waste in the vessel and accumulation of  
material adhering to the agitator, and by securing a

continuous supply of air to the waste in the vessel and distribution of the air throughout the waste in order to maintain and promote the biological decaying process therein the emission of annoying odours from the vessel at  
5 the same time being avoided or extensively reduced.

A further object of the invention is to provide an automatic intermittent discharge of composted material from the vessel through the discharge pipe.

These objects as well as other objects that will be  
10 apparent from the following description of an illustrative embodiment of the invention are achieved by method and machine of the kind referred to above with the characterizing features of claim 1 and claim 2, respectively.

15 In the drawings

**FIG 1** is a vertical cross sectional view of the composting machine in the presently preferred embodiment thereof,

**FIG 2** is a plan view of the composting machine,

20 **FIG 3** is a cross sectional view of the composting machine along line III-III in FIG 1,

**FIG 4** is an enlarged cross sectional view of an agitator wing along line IV-IV in FIG 1, and

25 **FIG 5** is an enlarged cross sectional view of the shredder along line V-V in FIG 1.

Referring to FIG 1 to 3 in the drawings the composting machine comprises a cylindrical vessel 10 having a circularly curved side wall 11, a top wall 12 and a bottom wall 13. The vessel is supported by a frame 14, and  
30 the side wall and top wall have an outside heat insulating layer partly indicated at 15. A hollow shaft 16 extending axially through the vessel centrally thereof is rotatably mounted in the vessel by a spherical ball bearing 17 mounted to the lower side of bottom wall 13, and a  
35 spherical ball bearing 18 mounted to the upper side of a

box girder 19 which is mounted to the vessel at the top thereof. Shaft 16 is connected to an electric drive motor 20 via a gear 21.

In the embodiment shown six wings 22, 23, 24, 25, 26, 5 and 27 are mounted to shaft 16 at different levels but any number of wings can be chosen. The wings are tubular, and each wing has a shorter cylindrical portion as shown at 25A for wing 25, and a longer portion 25B which has been flattened, and is mounted at portion 25A to a socket 28 10 which is passed onto shaft 16 and is connected therewith by a screw connection 29.

The interior of one of the lowermost wings, in the embodiment shown wing 22 which is located adjacent bottom wall 13, communicates with the interior of the hollow shaft 15 16. Said wing is closed at the outer end thereof and is provided with a number of nozzles 30, in the embodiment shown four nozzles, the hollow wing forming a manifold for the nozzles which are inclined towards the bottom wall 13 and have their outlet openings close to the bottom wall as 20 will be seen from FIG 4. The intended rotational direction of shaft 16 is indicated by an arrow 31, and in relation to this rotational direction nozzles 30 project from wing 22 at the "upstream" side thereof.

In a modified embodiment a hose on each nozzle forms 25 the outlet end portion thereof, said hose sliding on the bottom wall 13.

On deck 19 there is mounted an electric fan 32 which takes in air from the surroundings and delivers air under pressure to a chamber 33. This chamber is divided into two 30 compartments 33A and 33B by a partition 34, which communicate with each other at 35 compartment 33A being connected to the outlet of the fan. An electric heater 36 extends into compartment 33A. The tubular shaft 16 projects at the open upper end thereof into chamber 33B an air seal 35 37 being provided around the shaft where it enters

compartment 33B. A temperature sensor 38 (thermostat) is provided in chamber 33B and is operatively connected to heater 36 to control heating of air supplied by fan 32 in dependence of the temperature of the air as sensed by  
5 sensor 38. The air passing into the hollow shaft 16 is supplied to the interior of vessel 10 through nozzels 30 via wing 22 of the agitator and can be kept at a predetermined elevated temperature by the heating device described. The sites where the air is delivered to the  
10 waste body are continuously displaced in circular paths in the waste body by the rotation of the rotating agitator.

A number of stationary agitators 39, in the embodiment disclosed three agitators, are mounted to the side wall 11 of the vessel and project radially from the  
15 inside surface thereof into vessel 10. These agitators are each located above a rotating wing on shaft 16 and close to the associated wing. Each agitator comprises a rod 40 and a tubular element 41 with axial projecting fins 42, which is rotatably mounted on the rod. The rod is effective as an  
20 agitator also if no tubular element is provided on the rod, particularly if the rod is threaded, but the finned tubular element improves the efficiency.

Adjacent bottom wall 13 an inlet opening 43 is provided in side wall 11, and an inlet unit 44 for  
25 delivering shredded waste to vessel 10 is connected to the inlet opening. Unit 44 comprises an intake 45 provided with a lid 46 and communicating at the lower end thereof with a chamber 47 closed by an end wall 48 at the lower end thereof. An electric motor 49 is mounted to end wall 48 and  
30 the drive pin thereof is connected to a shaft 50 projecting from below into chamber 47. At the upper end a rotor 51 is mounted to shaft 50, which has four radial wings 52 spaced 90° and angled so as to exert on material supplied to the chamber a downward force when the shaft is rotated in the  
35 direction indicated by an arrow 53. A shedder, FIG. 5, is

located below the rotor and comprises a disc 54, mounted to shaft 50 and having four edge recesses 55 equally spaced. Two cutting blades 56 are mounted to the upper side of the disc and have the cutting edge 57 thereof located each in one of two diametrically opposite recesses 55. Two stationary counter blades, one being shown at 58, are mounted in chamber 47 diametrically opposite each other for cooperation with cutting blades 56. Four fins 59 are mounted to the lower side of disc 54 extending radially and equally spaced, and these fins are at the same level and have substantially the same height as inlet opening 43 to be in register therewith when passing the inlet opening during rotation of shaft 50.

Organic waste to be composted is supplied to intake 45 and is positively transported downwards through the intake by wings 52 on rotor 51 when the rotor is being rotated at high speed by motor 49. The waste is delivered to the shredder wherein the waste is comminuted by cutting blades 56 in cooperation with counter blades 58. The shredded waste falls down through recesses 55 and is captured by the rotating fins 59 which throw the shredded waste towards and through inlet opening 43 into vessel 10.

In the vessel the hollow shaft 16 is kept rotating at 2 to 6 rpm by motor 20 in the rotational direction indicated by arrow 31. When the lower wings 22 and 23 are passing inlet opening 43 the shredded waste is thrown towards said wings, which involves a risk that the waste which often has a high content of humidity and may be sticky will adhere to the wings and will accumulate there causing breakdown of the rotating agitator and/or overloading of motor 20 and possibly breakdown thereof. In order to eliminate said risk there is mounted to the outer end of each of wings 22 and 23 a baffle 60 which extends "upstream" from the wing in relation to the rotational direction indicated by arrow 31 and follows substantially

the curved shape of side wall 11 spaced therefrom about two or three cm. The "downstream" edge of the baffle forms a scraper positioned close to the inside surface of side wall 11. The baffle has such a length that it covers the inlet opening during rotation of the wing over about 30°. It has been found that waste thrown towards the baffle is effectively prevented from striking the associated wing. On the other hand, waste striking the baffle easily slides off the baffle without accumulating on the same.

The waste received by the vessel is continuously agitated and mixed by wings 22 to 27 of the rotating agitator and by the stationary agitators 39. The rotating and stationary agitators in co-operation prevent the formation of lumps and clods in the waste body. Lumps and clods could jeopardize an even distribution of the supplied air in the waste body. In order to enhance the agitation rods 61 and blades 62 can be provided projecting upwards and downwards from wings 22 and 23 as disclosed in FIG 1. As more and more waste is supplied to the vessel the level of waste will rise therein under continuous agitation of the material. Wings 25, 26 and 27 are angled so as to exert on the material a lifting action. The air delivered through nozzles 30 from fan 32 is supplied at the bottom of the waste body in the vessel and passes upwards through the waste body which is kept loose and porous by the agitation so that the air supplied will intimately contact the waste particles in order to maintain the microbiological process that shall take place in the vessel in order to decompose the waste material. Since the air is supplied at the bottom of the vessel from nozzles angled towards the bottom at the "upstream" side of wing 22 there is no risk of clogging of the nozzles. The temperature of the air supplied should be about 20 to 25°C, and if the air taken from the surroundings by fan 32 does not be at that temperature heating of the air is effected to the extent necessary in

order to increase the temperature of the air supplied to the desired level under the control av sensor 38. In order to start up the process in the vessel the air supplied may be heated to an even higher temperature, e. g. 30 to 35°C  
5 during an initial phase of the operation of the composting machine.

During the microbiological process humidity in the waste being processed in the vessel will evaporate and must be removed from the vessel. A suction fan 63 is connected  
10 to a conduit 64 opening through top wall 12 in the interior space of the vessel at 65 to evacuate humidity therefrom the humid air as well as odours developed by the process in the vessel being delivered by fan 63 to an exhaust conduit 66. Fans 32 and 63 should be adjusted to each other such  
15 that there is always maintained in the vessel a negative pressure (underpressure). Heat insulation 15 substantially reduces the formation of condensate on the inside surfaces of the vessel. Condensate accumulated on the inside surfaces of the vessel could return to the material mass  
20 and increase the humidity thereof. Therefore, the formation of condensate should be prevented as far as possible.

The material rising continuously through the vessel during the decomposing process eventually reaches an upper level indicated at 67 in FIG 1 where the waste has been  
25 converted to humus. A discharge pipe 68 is connected to vessel 10 at level 67 and extends downwards along the outside of side wall 11. At the lower end of the discharge pipe a flap 69 is pivotally mounted at 70 and is kept in a closed position shown in solid lines by the negative  
30 pressure maintained in the vessel, against the bias afforded by a counterweight 71. Material is transferred from the material body in the vessel at level 67 by means of a tubular paddle 72 which is mounted to the hollow shaft and rotating therewith and over the major length thereof  
35 has been flattened and has the flat surfaces thereof

extending substantially vertically. Fan 63 is stopped at intervals by means of a timer to break the negative pressure in the vessel so that flap 69 will be swung to an open position indicated by a dot and dash line under the  
5 bias of the counterweight 71 in order to discharge the material collected in discharge pipe into a suitable receiver.

It is estimated that a composting machine as described operating according to the method of the  
10 invention and having a capacity of handling a daily supply of 60 to 75 kg waste depending on the character and condition thereof will produce high quality composted material (humus) in about 4 weeks.

## CLAIMS

1. Composting machine for decomposition of compost-  
5 able waste, comprising a vessel (10), a waste inlet (43) at  
the bottom of the vessel, means (56, 58) for shredding  
waste supplied to the inlet, an agitator (16, 22-27) in the  
vessel, comprising a rotatable vertical tubular shaft (16),  
and wings (22-27) projecting radially from the shaft to  
10 agitate and mix the waste supplied to the vessel through  
the inlet, at least one of said wings being skewed or  
bevelled to lift the waste in the vessel and thus move the  
waste from the bottom of the vessel to the top thereof, air  
nozzles (30) for the supply of air to the vessel (10)  
15 located on the hollow shaft and communicating with the  
interior thereof to be displaced in a horizontal circular  
path through waste in the lower region of the vessel by the  
rotation of the hollow shaft, a discharge pipe (68) for  
decomposed waste at the top of the vessel, and means (32,  
20 63) providing a flow of air from the air nozzles through  
the vessel and the waste therein to the surroundings  
through an air outlet, **characterized** in that said nozzles  
(30) are located on the trailing edge of at least one  
tubular wing forming a manifold for the nozzles which are  
25 distributed along said edge and are directed obliquely  
towards the bottom of the vessel to open in the vessel  
close to the bottom, and that said means (32, 63) providing  
the flow of air is adjusted to maintain a negative pressure  
in the vessel.

30 2. Composting machine as in claim 1, **characterized** in  
that said means (32, 63) providing the flow of air  
comprises a pressure fan (32) for supplying air under  
pressure to said nozzles (30), and a suction fan (63) for  
evacuating air from the interior of said vessel (10).

3. Composting machine as in claim 1 or 2,  
**characterized** by means (36) for preheating the air supplied  
by said pressure fan (32).

4. Composting machine as in any of claims 1 to 4,  
5 **characterized** by a balanced flap (69) at the discharge  
opening of said discharge pipe (68) said flap being biased  
to an open position thereof to be maintained in a closed  
position thereof by the negative pressure in the vessel.

5. Composting machine as in any of claims 1 to 4,  
10 **characterized** by stationary agitators (39) extending into  
said vessel (10) radially of said shaft (16).

6. Composting machine as in claim 5, **characterized** in  
that said stationary agitators (39) comprise cylindrical  
rods (40).

15 7. Composting machine as in claim 6, **characterized** in  
that said cylindrical rods (40) are threaded.

8. Composting machine as in claim 6, **characterized** in  
that fins (42) are rotatably mounted on said cylindrical  
rods (40) said fins extending along the rods and projecting  
20 radially therefrom.

9. Composting machine as in any of claims 1 to 8,  
**characterized** in that on one or more wings (22, 23) on said  
shaft (16), located close to the bottom (13) of the vessel  
(10) there is provided at the outer end thereof a baffle  
25 60) having the leading end close to the inside surface of  
the side wall (11) of the vessel (10) and diverging from  
said inside surface towards the trailing end of the baffle  
said baffle covering the inlet (43) provided in the side  
kwall (11) of the vessel, when passing by at the rotation  
30 of the agitator (16, 22-27).

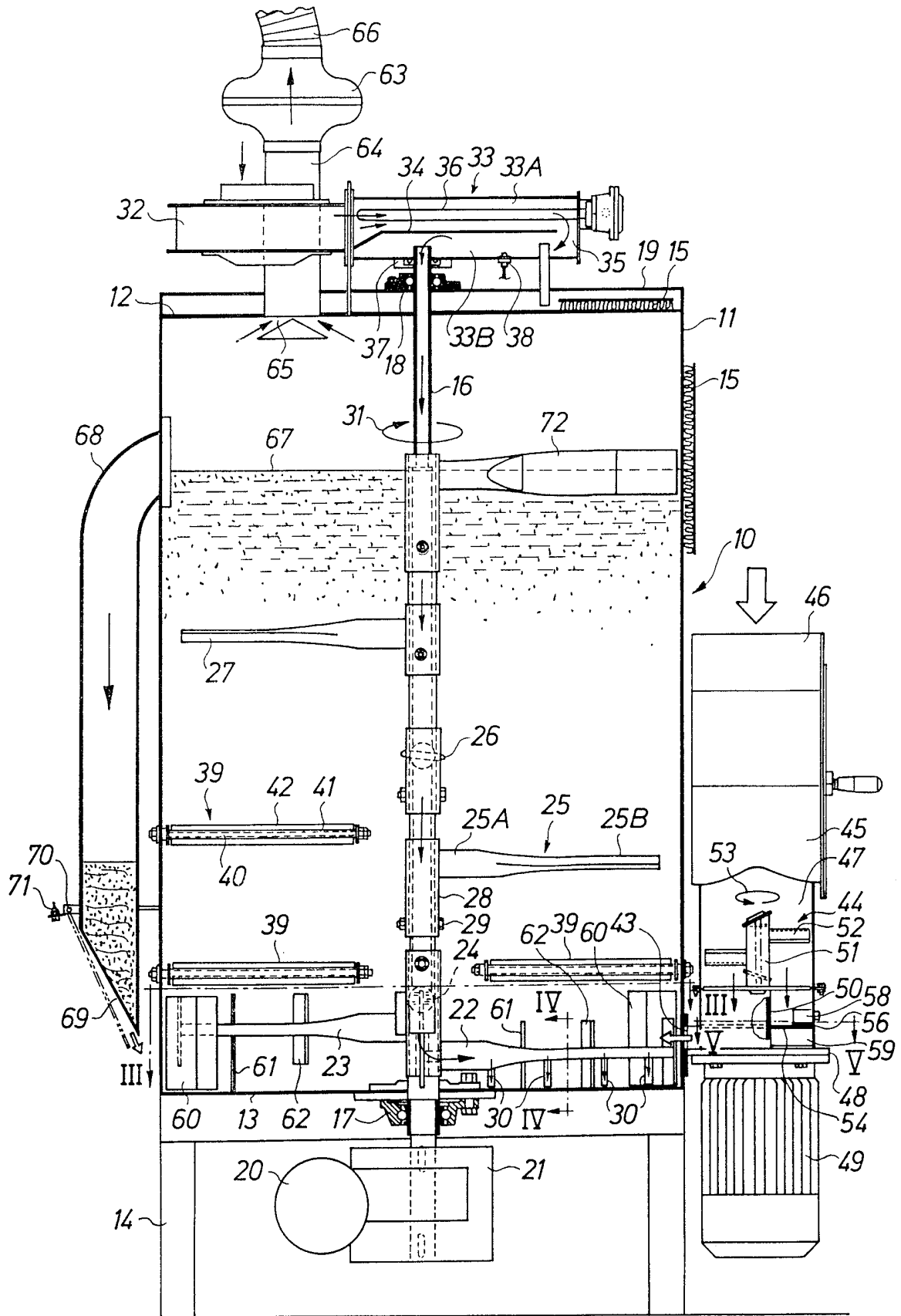

FIG. 1

SUBSTITUTE SHEET (RULE 26)

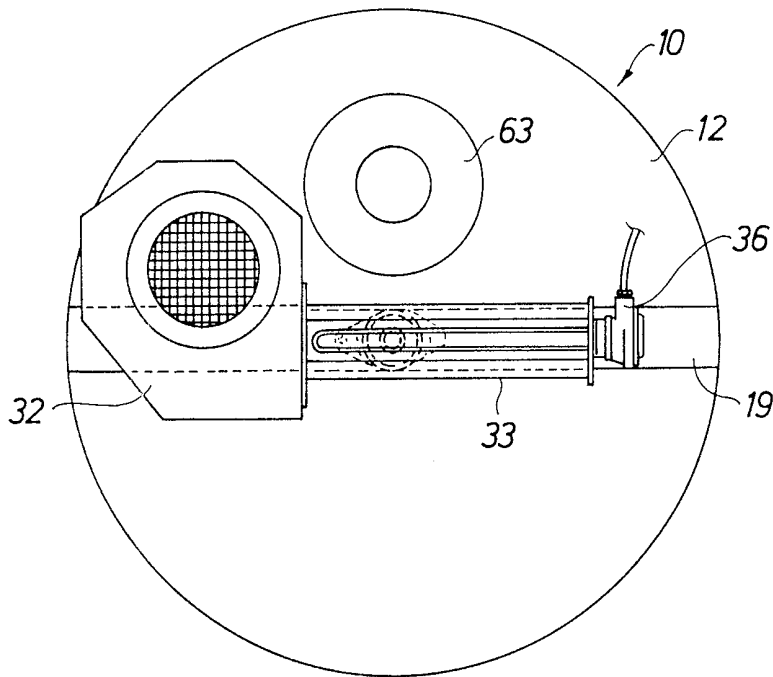

FIG. 2

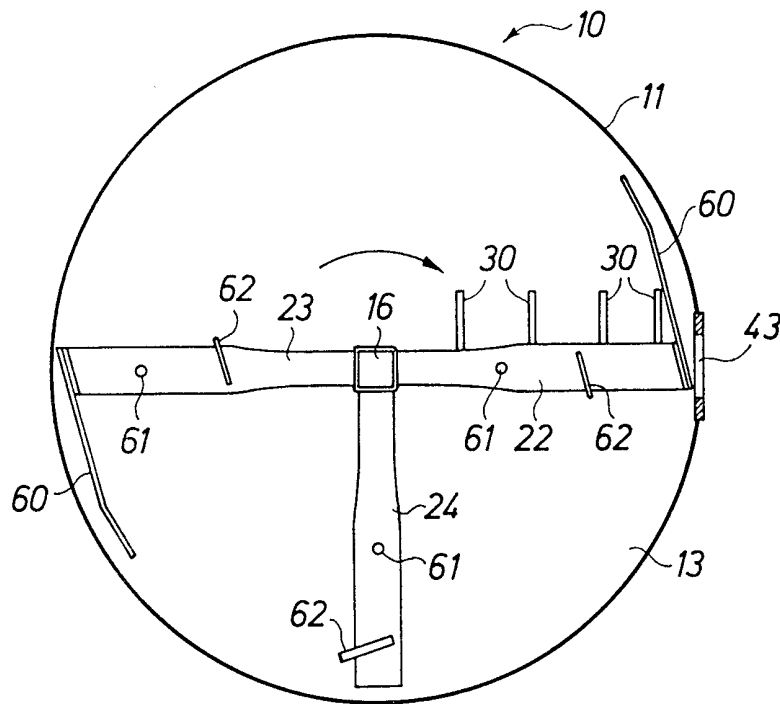

FIG. 3

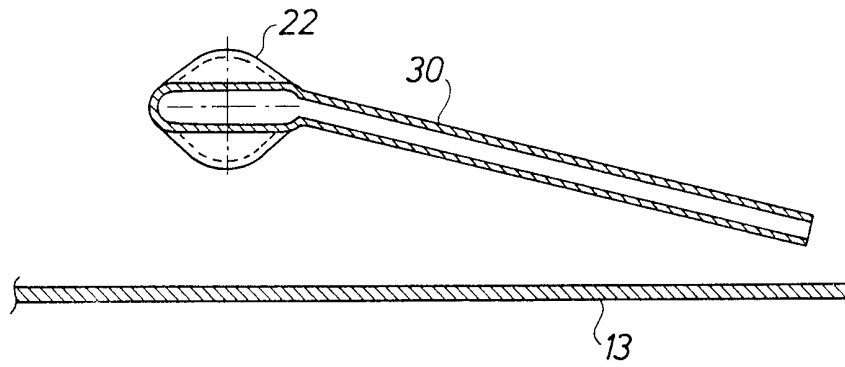

FIG. 4

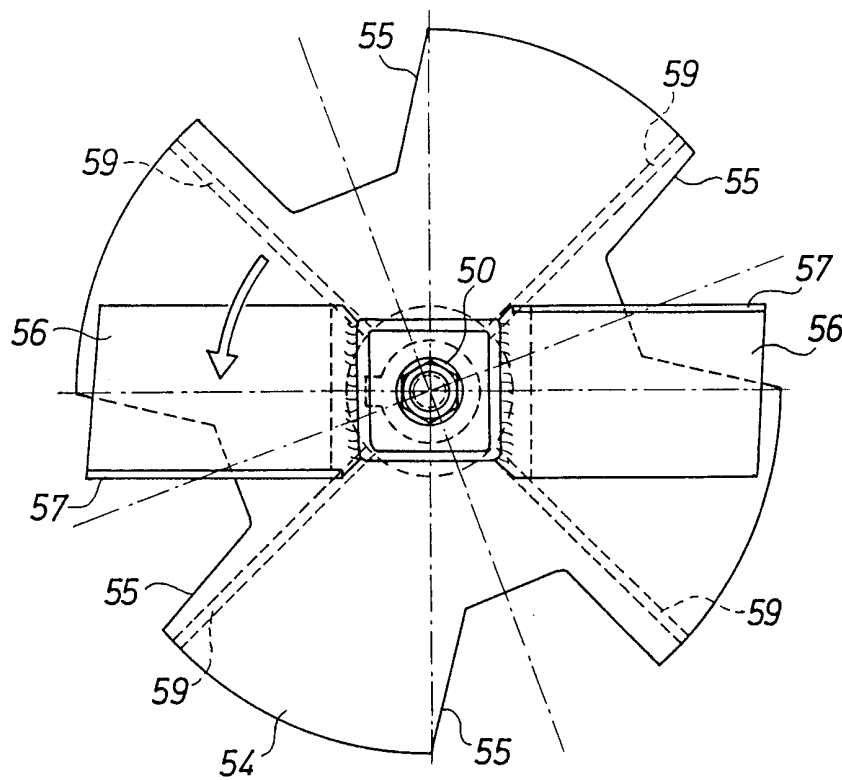

FIG. 5

## INTERNATIONAL SEARCH REPORT

International application No.

PCT/SE 99/01069

## A. CLASSIFICATION OF SUBJECT MATTER

IPC6: C05F 17/02

According to International Patent Classification (IPC) or to both national classification and IPC

## B. FIELDS SEARCHED

Minimum documentation searched (classification system followed by classification symbols)

IPC6: C05F

Documentation searched other than minimum documentation to the extent that such documents are included in the fields searched

SE,DK,FI,NO classes as above

Electronic data base consulted during the international search (name of data base and, where practicable, search terms used)

## C. DOCUMENTS CONSIDERED TO BE RELEVANT

Category*	Citation of document, with indication, where appropriate, of the relevant passages	Relevant to claim No.
Y	WO 9746499 A1 (FRANZEN, BO), 11 December 1997 (11.12.97), page 3, line 13 - page 6, line 25; page 7, line 21 - page 8, line 5, figures 1-9 --	1-9
Y	WO 9316017 A1 (NTP-YHTY-MÄ OY), 19 August 1993 (19.08.93), page 5, line 4 - page 6, line 17; page 9, line 25 - page 10, line 5, figures 1-7 --	1-9
Y	EP 0599661 A1 (SHIMIZU, HIROSHI), 1 June 1994 (01.06.94), column 16, line 18 - line 44, figure 15 --	1-9

 Further documents are listed in the continuation of Box C. See patent family annex.

\* Special categories of cited documents:

"A" document defining the general state of the art which is not considered to be of particular relevance

"E" earlier document but published on or after the international filing date

"L" document which may throw doubts on priority claim(s) or which is cited to establish the publication date of another citation or other special reason (as specified)

"O" document referring to an oral disclosure, use, exhibition or other means

"P" document published prior to the international filing date but later than the priority date claimed

"T" later document published after the international filing date or priority date and not in conflict with the application but cited to understand the principle or theory underlying the invention

"X" document of particular relevance: the claimed invention cannot be considered novel or cannot be considered to involve an inventive step when the document is taken alone

"Y" document of particular relevance: the claimed invention cannot be considered to involve an inventive step when the document is combined with one or more other such documents, such combination being obvious to a person skilled in the art

"&amp;" document member of the same patent family

Date of the actual completion of the international search

25 October 1999

Date of mailing of the international search report

17 -11- 1999

Name and mailing address of the ISA/

Swedish Patent Office

Box 5055, S-102 42 STOCKHOLM

Facsimile No. + 46 8 666 02 86

Authorized officer

Nils Engnell/MP

Telephone No. + 46 8 666 25 00

## INTERNATIONAL SEARCH REPORT

International application No.

PCT/SE 99/01069

C (Continuation). DOCUMENTS CONSIDERED TO BE RELEVANT		
Category*	Citation of document, with indication, where appropriate, of the relevant passages	Relevant to claim No.
Y	WO 9301149 A1 (HULTSTRÖM, BROR, IVAR ET AL), 21 January 1993 (21.01.93), page 3, line 37 - page 4, line 24; page 8, line 7 - page 9, line 17, figures 1,9  --	1,2-14
A	SE 502018 C2 (LISS-OLA LINDKVIST), 17 July 1995 (17.07.95)  -- -----	1,2-14

## INTERNATIONAL SEARCH REPORT

Information on patent family members

28/09/99

International application No.

PCT/SE 99/01069

Patent document cited in search report	Publication date	Patent family member(s)	Publication date
WO 9746499 A1	11/12/97	AU 3199397 A EP 0912464 A SE 9602258 D	05/01/98 06/05/99 00/00/00
WO 9316017 A1	19/08/93	AU 3454893 A FI 94859 B,C FI 920599 A,V	03/09/93 31/07/95 13/08/93
EP 0599661 A1	01/06/94	DE 69314286 D,T JP 7016559 A JP 7148479 A	05/03/98 20/01/95 13/06/95
WO 9301149 A1	21/01/93	CA 2112662 A EP 0592545 A SE 9102062 D	21/01/93 20/04/94 00/00/00
SE 502018 C2	17/07/95	SE 9401759 A SE 9501150 A	17/07/95 01/10/96