



(51) International Patent Classification:

F16L 55/10 (2006.01) F15B 21/06 (2006.01)
E21B 33/064 (2006.01) F16L 55/103 (2006.01)

(21) International Application Number:

PCT/US2014/055495

(22) International Filing Date:

12 September 2014 (12.09.2014)

(25) Filing Language:

English

(26) Publication Language:

English

(30) Priority Data:

61/877,888 13 September 2013 (13.09.2013) US

(71) Applicant: BIOFILM IP, LLC [US/US]; 990 Ironwood Drive, Minden, NV 89423 (US).

(72) Inventors: WRAY, Daniel, X.; P.o. Box 2649, Minden, NV 89423 (US). LIU, Reed, Nicholas; 10115 Hampton Park Dr., Reno, NV 89521 (US). CENICEROS, Ericson, C.; 990 Ironwood Drive, Minden, NV 89423 (US).

(74) Agents: SEIDMAN, Stephanie, L. et al.; Mckenna Long & Aldridge LLP, 4435 Eastgate Mall, Suite 400, San Diego, CA 92121 (US).

(81) Designated States (unless otherwise indicated, for every kind of national protection available): AE, AG, AL, AM, AO, AT, AU, AZ, BA, BB, BG, BH, BN, BR, BW, BY, BZ, CA, CH, CL, CN, CO, CR, CU, CZ, DE, DK, DM, DO, DZ, EC, EE, EG, ES, FI, GB, GD, GE, GH, GM, GT, HN, HR, HU, ID, IL, IN, IR, IS, JP, KE, KG, KN, KP, KR, KZ, LA, LC, LK, LR, LS, LU, LY, MA, MD, ME, MG, MK, MN, MW, MX, MY, MZ, NA, NG, NI, NO, NZ, OM, PA, PE, PG, PH, PL, PT, QA, RO, RS, RU, RW, SA, SC, SD, SE, SG, SK, SL, SM, ST, SV, SY, TH, TJ, TM, TN, TR, TT, TZ, UA, UG, US, UZ, VC, VN, ZA, ZM, ZW.

(84) Designated States (unless otherwise indicated, for every kind of regional protection available): ARIPO (BW, GH, GM, KE, LR, LS, MW, MZ, NA, RW, SD, SL, ST, SZ, TZ, UG, ZM, ZW), Eurasian (AM, AZ, BY, KG, KZ, RU, TJ, TM), European (AL, AT, BE, BG, CH, CY, CZ, DE, DK, EE, ES, FI, FR, GB, GR, HR, HU, IE, IS, IT, LT, LU,

[Continued on next page]

(54) Title: MAGNETO-CRYOGENIC VALVES, SYSTEMS AND METHODS FOR MODULATING FLOW IN A CONDUIT

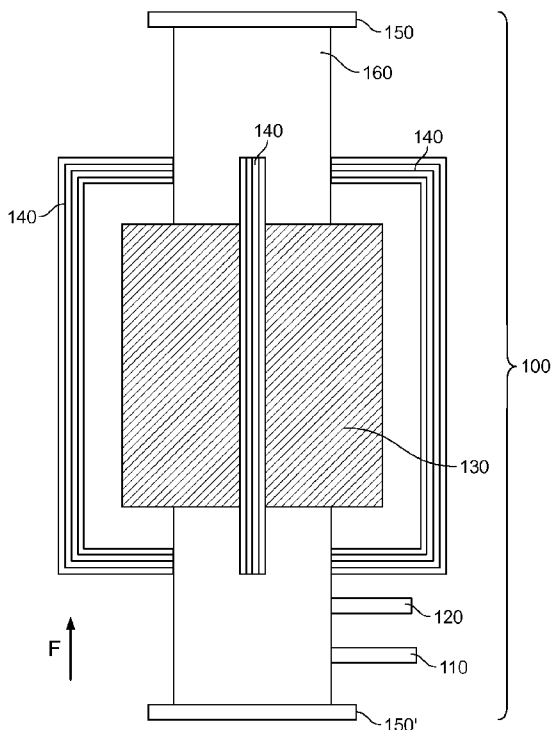

FIG. 1

(57) Abstract: A magneto-cryogenic valve (100), comprising: a connector (150) for connecting the magneto-cryogenic valve to a conduit through which a fluid flows; a heat transfer system (130); a first injector device (110) for injecting magnetically susceptible particles into the fluid; a valve chamber; and a magnetic field generating device (140), wherein: the valve chamber is connectable in fluid communication with the conduit so that the fluid of the conduit flows through the valve chamber; the magnetic field generating device produces a magnetic field comprising field lines and at least a portion of the field lines penetrate through the fluid in the valve chamber and interact with the injected magnetically susceptible particles; and the heat transfer system removes thermal energy from the valve chamber and the fluid therein.

WO 2015/038961 A1

LV, MC, MK, MT, NL, NO, PL, PT, RO, RS, SE, SI, SK, SM, TR), OAPI (BF, BJ, CF, CG, CI, CM, GA, GN, GQ, GW, KM, ML, MR, NE, SN, TD, TG).

Published:

Declarations under Rule 4.17:

- *as to applicant's entitlement to apply for and be granted a patent (Rule 4.17(ii))*
- *as to the applicant's entitlement to claim the priority of the earlier application (Rule 4.17(iii))*

- *with international search report (Art. 21(3))*
- *before the expiration of the time limit for amending the claims and to be republished in the event of receipt of amendments (Rule 48.2(h))*

- 1 -

MAGNETO-CRYOGENIC VALVES, SYSTEMS AND METHODS FOR MODULATING FLOW IN A CONDUIT

RELATED APPLICATIONS

Benefit of priority is claimed to U.S. Provisional Application No. 61/877,888 to
5 Daniel X. Wray, titled "MAGNETO-CRYOGENIC VALVES, SYSTEMS AND
METHODS FOR MODULATING FLOW IN A CONDUIT," filed September 13, 2013, the
subject matter of which is incorporated by reference herein in its entirety.

This application also is related to corresponding U.S. Patent Application No.
14/485,227, filed the same day herewith, titled "MAGNETO-CRYOGENIC VALVES,
10 SYSTEMS AND METHODS FOR MODULATING FLOW IN A CONDUIT," which also
claims priority to U.S. Provisional Application Serial No. 61/877,888. The subject matter
of U.S. Patent Application No. 14/485,227 is incorporated by reference herein in its
entirety.

FIELD

15 The present invention relates generally to controlling the flow of a fluid, *e.g.*,
petroleum and/or natural gas, through or from a conduit, *e.g.*, a pipeline or oil well.
Provided are magneto-cryogenic valves, systems incorporating the magneto-cryogenic
valves and methods for reversibly modulating flow of a fluid through a conduit.

BACKGROUND

20 Metal conduits, such as gas, water and oil pipelines, can fail due to age, fatigue,
corrosion, abuse, neglect and when used in the environment, natural forces that can fracture
or rupture the pipe, such as seismic activity. Failure can result in uncontrolled fluid flow. A
common device used to control such uncontrolled flow of fluid out of a conduit is a blow-
out preventer. One or more blow-out preventers can be attached directly to the wellhead and
25 operate to rapidly close an open well hole or the space between the casing and the drill pipe
to prevent the escape of pressurized oil or gas. These devices work essentially as plugs.
Ram type blow-out preventers are insertable laterally into the casing. Annular type blow-
out preventers expand radially to fill the casing. Blow-out preventers are known in the art
(see, *e.g.*, U.S. Pat. Nos. 5,507,465, 5,746,249, 5,875,841 and 6,024,172). U.S. Pat.
30 Application Pub. No. 2011/0297394 describes a magneto-rheological blow-out preventer
that uses magnets and a magnetic fluid. Although blow-out preventers are effective in

preventing blow-outs and any ensuing fires, if the wellhead is damaged or if conduit failure occurs before the blow-out preventers, blow-out preventers may become ineffective for stopping fluid flow.

Valves and other devices have been used in attempts to stop the flow of fluid through
5 breached conduits. Many of the apparatus described in the art install a plug in a flowing
high pressure pipeline, where the plug can, in some cases, serve as a fully operative valve.
Most of these methods include a means to cut a hole through the conduit or to cut a section
out of the flowing conduit, withstanding the pressure from the fluid within the conduit, and
then permanently placing a plug in position. For example, U.S. Pat. No. 3,699,996 describes
10 a device that includes a drilling and reaming tool that cuts a cylindrical hole through the
flowing pipeline using a powered rotational drive and an axial hydraulic ram. A valve seat
and a valve plug are positioned behind the drill and the seat automatically snaps into
position upon completion of the drilling and removal of the drill bit. This apparatus requires
complex sealing and locking components and requires that the drill bit be removed from the
15 seat/plug assembly before the valve is operable. Similar devices are described in U.S. Pat.
Nos. 3,532,113, 3,993,137 and 4,552,170. Some of these devices require a complex variety
of seals and packings to maintain a fluid tight valve. Therefore, devices and methods that
operate simply and effectively to reversibly seal a flowing high pressure conduit, such as
pipeline, with a minimum of complex components, are needed.

20 Accordingly, a need exists for compositions, methods and devices that allow for
reversibly plugging or stopping the flow of a fluid through a conduit.

SUMMARY

Among the objects herein, provided are devices, systems and methods for reversibly
plugging or stopping the flow of a fluid through a conduit.

25 Provided are devices, systems and methods to introduce an injection slurry
composition containing magnetically susceptible particles into a fluid within a conduit such
that the temperature of at least a portion of fluid is reduced to a temperature below which
the fluid becomes a solid, forming a frozen plug of solid adhered to the conduit or device
inner walls, thereby reversibly plugging the conduit. Also provided are methods of
30 reversibly preventing flow in a conduit. The devices, methods and systems result in the *in*
situ formation of a reversible plug that can stop the flow of fluid through a conduit. The
devices, systems and methods described herein include an efficient heat sink for effective
heat transfer from a flowing fluid in a conduit, resulting in rapid formation of a frozen plug

of fluid without requiring that the flow of fluid within the conduit be stopped in order to form a frozen plug.

5 Provided are magneto-cryogenic valves that include a heat transfer system, a first injector device, optionally a second injector device, a valve chamber and a magnetic field generating device. The magneto-cryogenic valves can be integrated into a conduit containing a fluid, or attached to such a conduit. The first injector and second injector are in fluid communication with the fluid within the conduit. The first injector can be used to inject an adhesion promoter composition into the fluid before the fluid reaches the heat transfer system of the magneto-cryogenic valve. The second injector can be used to inject
10 an injector slurry composition containing magnetically susceptible particles into the fluid before the fluid reaches the heat transfer system and magnetic field generating device(s) of the magneto-cryogenic valve.

The heat transfer system of the magneto-cryogenic valve can adapted to fit to a surface of at least a portion of a conduit with sufficient thermal intimacy that the two are in
15 thermal communication and thermal energy can by transferred between the conduit and the heat transfer system. The heat transfer system can be integrated into the magneto-cryogenic valve to remove thermal energy from fluid of the conduit. Any heat transfer system known in the art that can be used for transfer of thermal energy can be used. In some applications, the heat transfer system includes a refrigeration system. Exemplary refrigeration systems
20 include a vapor compression system, a heat exchange unit, a cryogenic cooling system, or an electric thermal transfer device or a combination thereof. In some applications, the heat transfer system of the magneto-cryogenic valve includes a cooling chamber suitable to contain a cryogen, and heat transfer is accomplished via cryogenic cooling. In these applications, the cooling can include evaporative cooling.

25 The heat transfer system of the magneto-cryogenic valve can include a detachable housing that includes at least two side portions for enclosing a section of a conduit and two end portions for engaging in sealing relation with opposite ends of the side portions, the side and end portions defining a cooling chamber when assembled around the conduit, the cooling chamber able to confine a volume of a cryogen, where at least a portion of the
30 cryogen is in its liquid phase and in thermal communication with the exterior surface of at least a portion of the section of conduit enclosed by the housing. In some application, the cooling chamber within the heat transfer device includes particles, filings, turnings, shavings, pellets, threads or beads or a combination thereof of a thermally conductive

material. The heat transfer system can include an inlet port for admitting a cryogen into the cooling chamber and an outlet port for discharging the spent cryogen out of the cooling chamber.

5 The heat transfer system of the magneto-cryogenic valve further can include a conductor surface, generally containing a thermally conductive material. The conductor surface can include aluminum, beryllium, brass, cadmium, carbon steel, chrome, chrome nickel steel, cobalt, copper, gold, iridium, iron, lead, magnesium, molybdenum, nickel, platinum, silver, stainless steel, tin or zinc, or any combination or alloy thereof. The heat exchange unit also can include baffles or fins in thermal communication with the conductor
10 surface or the surface of the heat transfer system in thermal communication with the conduit. The baffles can be positioned to direct cryogen flow through the heat transfer system. The fins can extend the thermal energy transfer surface of the heat transfer device to expedite thermal energy transfer to the cryogen and/or particles of thermally conductive material within the heat transfer system.

15 The magneto-cryogenic valve further can include a heating device adjacent to the heat exchange unit. Any heating device known in the art can be used. Exemplary heating devices include Curie temperature heaters, conductor-in-conduit heaters, heater strips, ceramic heaters, resistance wire heaters and resistance ribbon heaters. The heaters can be activated to donate thermal energy to the vicinity of the conduit attached to the heat transfer
20 system, thereby accelerating melting of the frozen plug in order to restore flow through the conduit. One or more heating devices can be used, and the positioning of the heating devices can be selected to achieve a desired result. In some applications, it is desirable to promote non-uniform melting of the frozen plug so that a channel is created in the vicinity of the heating units, restoring at least partial flow of fluid within the channel while the
25 frozen plug is still at least partially adhered to the inner wall of the conduit. This prevents launching of the frozen plug through the conduit.

The magneto-cryogenic valves include one or more magnetic field generating devices. In some applications, the magnetic field generating device includes one or more electromagnets. In some applications, the magnetic field generating device includes one or
30 more permanent magnets. In some applications, the magnetic field generating device includes one or more electromagnets and one or more permanent magnets. When the magnetic field generating device includes a permanent magnet, it may be made of any material known in the art for producing a permanent magnet. The permanent magnet can

include a ferrite material or a rare earth element. The permanent magnet can include a rare earth material. For example, the magnetic field generating device can include a permanent magnet that is a Nd-Fe-B type, Sm-Co type or Sm-N-Fe type rare earth permanent magnet, or any combination of these magnets. The magnets can be mounted on movable
5 tracks. The tracks can allow the positioning of the magnets in the magnetic field generating device and with respect to the conduit to which the magneto-cryogenic valve is attached of the chamber of the magneto-cryogenic valve through which the fluid of the conduit flows. Variable positioning of the magnets allows for modulating of the resulting effective magnetic fields produced by the magnet(s). The magnetic field generating device can
10 include a plurality of electromagnets in which oscillation of the B-field can be induced.

The first and second injectors of the magneto-cryogenic valves provided herein can include an isolation mechanism for controlling the flow of material through the injectors. For example, activatable flow modulating valves can be included to adjust the flow of material through the injector(s). The injectors also can include other components, such as
15 one or more or a combination of a flow rate meter, an emergency shut-off valve, an over-pressure valve, a diverter valve, a heating unit or a thermal monitoring device. The magneto-cryogenic valve can be a unit that is integrated into a conduit so that the fluid flowing through the conduit flows through a valve chamber of the magneto-cryogenic valve. Until activated, the magneto-cryogenic valve functions as any other tubular or portion of the
20 conduit and serves as a prophylactic safety device. The magneto-cryogenic valve also can be attached to a ruptured conduit to act as an emergency shut-off valve.

Also provided are systems for extracting thermal energy from a conduit containing a fluid. The systems include a magneto-cryogenic valve as described herein and an injector slurry supply module. The system can include a pressure regulator system connected to the
25 injector slurry supply module for modulating flow of an injector slurry composition to an injector. The injector slurry supply module is in fluid communication with an injector of the magneto-cryogenic valve and provides an injector slurry composition to the injector. In some applications, the system also includes an adhesion promoter composition supply module, which provides an adhesion promoter composition to an injector. The system can
30 include a pump in fluid communication with the adhesion promoter composition supply module to modulate flow of the adhesion promoter composition to the injector. When the magneto-cryogenic valve includes a heat transfer system that utilizes a cryogen, the systems provided herein also can include a cryogen supply module. The system also can include

one or more or a combination of flow control valves, diverter valves, pressure relief valves, pressure monitoring devices, temperature monitoring devices, or flow rate measuring devices. A computer control module also can be included in the system.

In the systems and methods provided herein, the injector slurry contains
5 magnetically susceptible particles. The magnetically susceptible particles can include particles that are paramagnetic or diamagnetic or ferromagnetic or any combination thereof. The particles can be made of any material that interacts with a magnetic field. The magnetically susceptible particles can include cobalt, Co-Zr alloys, Co-Nb alloys, dysprosium, Fe-Si alloys, gadolinium, iron, mu metal (nickel iron alloy), nickel, permalloys
10 (iron-nickel alloys), rare earth-transition metal alloys, spinel ferrites or supermalloy or any combination or alloy thereof. The magnetically susceptible particles can include a Gd-Co or Fe-Tb alloy. The magnetically susceptible particles can include cobalt, iron, nickel, magnetite (Fe_3O_4) or maghemite (Fe_2O_3) or combinations thereof.

In the systems and methods herein, the magnetically susceptible particles are
15 selected to have a thermal conductivity greater than the fluid within the conduit. The magnetically susceptible particles can be selected to have a thermal conductivity greater than $0.2 \text{ W}/(\text{m}\cdot\text{K})$, or greater than $0.5 \text{ W}/(\text{m}\cdot\text{K})$, or greater than $0.75 \text{ W}/(\text{m}\cdot\text{K})$, or greater than $1 \text{ W}/(\text{m}\cdot\text{K})$, or greater than $5 \text{ W}/(\text{m}\cdot\text{K})$, or greater than $10 \text{ W}/(\text{m}\cdot\text{K})$, or greater than $20 \text{ W}/(\text{m}\cdot\text{K})$, or greater than $30 \text{ W}/(\text{m}\cdot\text{K})$, or greater than $40 \text{ W}/(\text{m}\cdot\text{K})$, or greater than $50 \text{ W}/(\text{m}\cdot\text{K})$ or greater than $100 \text{ W}/(\text{m}\cdot\text{K})$. The magnetically susceptible particles can be of a
20 shape. Exemplary shapes include cubes, flakes, granules, cylinders, rings, rods, needles, prisms, disks, fibers, pyramids, spheres, spheroids, prolate spheroids, oblate spheroids, ellipsoids, ovoids, hexahedrons, hexagonal prisms, tetrahedrons, octahedrons, truncated octahedrons, dodecahedrons, triangular prisms or random non-geometric shapes or any
25 combinations of these shapes.

When used in the systems or methods provided herein, the magnetically susceptible particles can be solid, or they can be hollow, or a combination of solid and hollow particles can be used. The magnetically susceptible particles can include a partial or complete coating. The coating can include a thermally conductive material or an oxide or a
30 combination thereof. Examples of a thermally conductive material that can be included in the coating are beryllium, brass, cadmium, carbon steel, chrome nickel steel, cobalt, copper, gold, iridium, iron, lead, magnesium, molybdenum, nickel, platinum, silver, stainless steel, tin or zinc, or any combination or alloy thereof. Exemplary oxides that can be included in

the coating include an oxide of alumina, aluminum, barium, beryllium, bismuth, chromium, cobalt, copper, gadolinium iridium, iron, magnesium, manganese, molybdenum, nickel, niobium, silica, silicon, silver, tantalum, thorium, tin, titanium, tungsten, vanadium, yttrium, zinc, zirconia or zirconium or combinations thereof. The magnetically susceptible particles
5 can include a partial or complete coating that contains a corrosion-resistant material.

Exemplary corrosion-resistant materials are zinc, magnesium and cadmium or an alloy of any two or more of these. The magnetically susceptible particles can include a partial or complete coating that contains a ferromagnetic material. For example, the magnetically susceptible particles can include a partial or complete coating that contains iron, nickel,
10 cobalt or a rare earth metal or any combination or alloy thereof.

When used in the systems or methods provided herein, the magnetically susceptible particles can have any geometry. The particles can have a uniform surface geometry or a non-uniform surface geometry. The magnetically susceptible particles can have a very broad particle size distribution (*e.g.*, from nanometer sized particles to particles 20 cm in
15 diameter). The magnetically susceptible particles can have a particle size greater than 100 μm and less than 5 cm. In some applications, the magnetically susceptible particles have a particle size between about 1000 μm and about 1 cm. The magnetically susceptible particles can have an average particle size between about 1000 μm and about 10 cm. The magnetically susceptible particles can have an average particle size between about 1 nm and
20 100 μm . The particle size distribution can be unimodal, bimodal or polymodal. In the systems and methods provided herein, the amount of magnetically susceptible particles in the injection slurry composition is from about 0.01% to about 95% based on the weight of the injection slurry composition.

In the systems and methods provided herein, the injector slurry composition can
25 include a carrier. Any material compatible with the magnetically susceptible particles can be used. The carrier can be a cryogen or a solvent or a combination thereof. For example, the carrier can contain a cryogen, *e.g.*, liquid nitrogen, liquid oxygen, liquid helium, liquid neon, liquid methane, liquid natural gas, liquid argon, liquid nitrous oxide, or liquid carbon dioxide or combinations thereof. The amount of carrier, such as a cryogen or solvent, in the
30 injector slurry composition can vary, and can be from 1% to 99% based on the weight of the injector slurry composition. The carrier also can contain a solvent, such as benzene, ethyl acetate, propyl acetate, butyl acetate, cyclohexanol, ether, methylethyl ketone, petroleum ether, *n*-hexane, heptane, cyclohexane, naphtha, isopropyl biphenyl, terpene, toluene,

xylene, hexamethyl disiloxane, octamethyl cyclotetrasiloxane, diphenyl tetramethyl disiloxane or trimethylsiloxy end-blocked polydimethylsiloxane fluids or a combination thereof. In some applications, the solvent can include acetaldehyde, acetone, acetonitrile, acrolein, benzene, benzonitrile, bromo-benzene, butanol, butyl acetate, *n*-butyl amine, *t*-butyl amine, butyl bromide, carbitol acetate, carbon disulfide, carbon tetrachloride, chlorobenzene, chloroform, cyclohexane, cyclohexanone, cyclopentane, *m*-dichlorobenzene, *o*-dichloro-benzene, diethyl carbitol, diethyl ether, dioxane, ethanol, ethyl acetate, ethyl bromide, ethylene glycol, ethyl methyl ketone, glycerin, heptane, heptanone, hexane, hexanol, 1,5-hexadiene, isoamyl acetate, isooctane, isopentane, isopropanol, methanol, methyl cyclohexane, nitroethane, nitromethane, *n*-octane, octanol, *i*-pentane, *m*-pentane, propanol, propylene glycol, pyridine, toluene, thiophene, trichloroethylene, *m*-xylene or *p*-xylene or any combination thereof. The amount of solvent in the injector slurry composition, when present as a carrier, is from about 0.05% to 75% based on the weight of the injector slurry composition.

In the systems and methods provided herein, the adhesion promoter supply module can be in fluid communication with the first injector of the magneto-cryogenic valve and provides an adhesion promoter composition to the second injector. The adhesion promoter composition can include any material that promotes adhesion of the fluid to the conduit or valve chamber wall, particularly a material that promotes adhesion of frozen fluid to a conduit wall. The adhesion promoter composition can include a surface tension reducer. Any surface tension reducer known in the art can be included in the composition. For example, the surface tension reducer can include a surfactant, a sulfonic acid, an alkali metal salt of a sulfonic acid, an alcohol, an amine, an ester, a siloxane, or a mono and dialkylated oxazoline where the alkyl chain length is between about 2 to about 30 carbons or any combination thereof. In some applications, the surface tension reduced contains a surfactant. The surfactant can include an anionic surfactant, a cationic surfactant, a nonionic surfactant, a zwitterionic surfactant, a fluorosurfactant, a silicone surfactant or an amphoteric agent or any combination thereof.

When the surface tension reducer is an anionic surfactant, it can be selected from among alkali metal alkyl sulfates, alkyl or alkylaryl sulfonates, linear or branched alkyl ether sulfates and sulfonates, alcohol polypropoxylated and/or polyethoxylated sulfates, alkyl or alkylaryl disulfonates, alkyl disulfates, alkyl sulphosuccinates, alkyl ether sulfates, linear and branched ether sulfates and mixtures thereof. When the surface tension reducer is

a cationic surfactant, it can be selected from among arginine methyl esters, alkanolamines and alkylenediamides and mixtures thereof. When the surface tension reducer is an amphoteric agent, it can be selected from among betaines, sulphobetaines, imidazoline betaines and alkyl amido propyl betaines. When the surface tension reducer is a nonionic surfactant, it can be selected from among condensation products of ethylene oxide with aliphatic alcohols having from 8 to 22 carbon atoms in either straight or branched chain configuration, condensation products of ethylene oxide with nonyl phenol, phenol, butyl phenol, di-nonyl phenol, octyl phenol or other phenols, sorbitan esters and amine oxides, ethoxylated C₁₀-C₂₀ alcohols, fatty acids, fatty amines or glyceryl esters, alkyl polyglycosides, methyl glucoside esters, and blends of such nonionic surfactants. The surface tension reducer can include a polyol or a derivative of a polyol.

In the systems and methods provided herein, the adhesion promoter composition can include an amount of surface tension reducer from about 0.01% to about 50% based on the weight of the adhesion promoter composition. The adhesion promoter composition can include a solvent. Any solvent compatible with the surface tension reducer can be included in the adhesion promoter composition. Exemplary solvents include acetaldehyde, acetone, acetonitrile, acrolein, benzene, benzonitrile, bromo-benzene, butanol, butyl acetate, *n*-butyl amine, *t*-butyl amine, butyl bromide, carbitol acetate, carbon disulfide, carbon tetrachloride, chlorobenzene, chloroform, cyclohexane, cyclohexanone, cyclopentane, *m*-dichlorobenzene, *o*-dichloro-benzene, diethyl carbitol, diethyl ether, dioxane, ethanol, ethyl acetate, ethyl bromide, ethylene glycol, ethyl methyl ketone, glycerin, heptane, heptanone, hexane, hexanol, 1,5-hexadiene, isoamyl acetate, isooctane, isopentane, isopropanol, methanol, methyl cyclohexane, nitroethane, nitromethane, *n*-octane, octanol, *i*-pentane, *m*-pentane, propanol, propylene glycol, pyridine, toluene, thiophene, trichloroethylene, water, *m*-xylene or *p*-xylene or any combination thereof. If present in the adhesion promoter composition, the solvent can be present in an amount from about 0.05% to about 85% based on the weight of the adhesion promoter composition.

In the systems provided herein that include a cryogen supply module, the cryogen supply module is in fluid communication with the heat transfer system of the magneto-cryogenic valve and provides a cryogen to the heat transfer system. Any cryogen known in the art can be included in the system. For example, the cryogen can include liquid carbon dioxide, liquid ammonia, liquified chlorofluorohydrocarbons, liquid nitrogen, liquid oxygen, liquid neon, liquid argon, liquid nitrous oxide, hydrofluoroethane,

pentafluoropropane, trichloromonofluoromethane or dichlorodifluoromethane, or a mixture or any combination thereof. The cryogen supply module can include a non-thermally conducting surface in contact with the environment to thermally isolate the cryogen supply module from the environment. The cryogen supply module can include a thermal
5 monitoring device for monitoring the temperature of the cryogen or the pipes carrying the cryogen or a combination thereof. The cryogen supply module can include a flow rate meter for determining the flow rate of cryogen from the module. The system can include a pump in fluid communication with the cryogen supply module and the heat transfer system for pumping the cryogen to the heat transfer system. The cryogen supply module also can
10 include one or more of a flow rate meter, a flow-control metering valve, an isolation valve, an emergency shut-off valve, an over-pressure valve, a diverter valve, a heating unit, or a thermal monitoring device or any combination thereof.

The systems provided herein can include a computer module for partial or complete automation of the system. The computer module can include a computer in communication
15 with and/or in control of any part of the magneto-cryogenic valve or element of the system containing the magneto-cryogenic valve. The computer module can control or allow automation of the magnetic field generating device, or the cryogen supply module, or the injector slurry module, or the adhesion promoter composition supply module or any combination thereof. In the systems provided herein, the computer module can include a
20 non-transitory computer-readable storage medium having a computer-readable program embodied therein for directing operation of the magneto-cryogenic valve and/or any component of the system.

Also provided herein are methods for temporarily preventing the flow of fluid in a conduit. The methods include activating a magneto-cryogenic valve as provided herein
25 attached to the conduit, or activating a system provided herein that includes a magneto-cryogenic valve attached to the conduit. The heat transfer system of the magneto-cryogenic valve is in thermal contact with at least one portion of the conduit and each of the first injector and second injector of the magneto-cryogenic valve when activated introduces a material into the fluid in the conduit, where the activated magneto-cryogenic valve or system
30 removes sufficient thermal energy from the fluid to cause the fluid to freeze to form a reversible plug that prevents the fluid from flowing past the plug through the conduit. Activating the magneto-cryogenic valve can include charging the heat transfer system so that it is able to extract thermal energy. When a cryogen cooled heat transfer system is part of

the magneto-cryogenic valve, charging the heat transfer system includes activating a cryogen supply module to provide cryogen to the heat transfer system.

Activating the magneto-cryogenic valve can include activating a pump attached to the adhesion promoter composition supply module to cause adhesion promoter to be
5 injected into the fluid within the conduit via the first injector of the magneto-cryogenic valve. Activating the magneto-cryogenic valve can include activating the pressure regulator system attached to the injector slurry supply module to cause injector slurry composition to be injected into the fluid of the conduit via the second injector of the magneto-cryogenic
10 valve. Activating the magneto-cryogenic valve can include activating the magnetic field generating device to produce magnetic fields. The strength, size, shape and position of the magnetic field generating device(s) can be selected so that the magnetic field generated produces field lines at least a portion of which penetrate through to the fluid flowing through the valve chamber and interact with the magnetically susceptible particles injected into the fluid flowing through the valve.

15 The magnetic fields of the magnetic field generating device interact with the magnetically susceptible particles of the injection slurry so that the magnetically susceptible particles are directed to a desired location or region within the conduit or valve chamber, *e.g.*, at least a portion of the particles can be directed to the inner wall of the conduit in the vicinity of attachment of the heat transfer system. For example, positioning of the
20 magnetically susceptible particles near the inner wall of the conduit results in the freezing of at least some portion of the fluid of the conduit onto the wall of the conduit or valve chamber or onto previously frozen fluid or magnetically susceptible particles attached to the inner wall of the conduit or valve chamber.

The release of the cold magnetically susceptible particles into the fluid of the
25 conduit can result in the precipitation of at least some portion of the fluid within the conduit onto the wall of the conduit or valve chamber or onto previously frozen fluid attached to a wall of the conduit or valve chamber or onto the magnetically susceptible particles to form frozen fluid coated particles. The frozen fluid coated particles can interact with particles attached to the wall of the conduit or valve chamber or onto previously frozen fluid attached
30 to a wall of the conduit or valve chamber. Frozen fluid concentrically can accumulate along the inside of the conduit or valve chamber, accelerated by the magnetically susceptible particles.

In the methods provided herein, the first injector of the magneto-cryogenic valve can be positioned so that the injection of the adhesion promoter composition into the fluid of the conduit occurs before the second injector introduces the injection slurry composition into the fluid of the conduit. The heat transfer system or the second injector injecting the
5 injection slurry composition or both is/are activated for a sufficient amount of time to form a frozen plug of fluid attached to an inner wall of the conduit or valve chamber that prevents flow of the fluid through the conduit.

When fluid flow is to be resumed in the conduit, *e.g.*, after repairs have been made, the methods provided herein can include as a step increasing the temperature in the vicinity
10 of the attachment of the heat transfer system to donate thermal energy to the conduit or plug or both, thereby at least partially melting the frozen plug and restoring at least partial flow of the fluid through the conduit. The temperature can be increased by activating a heating device. Any heating device known in the art can be used. For example, the heating device can include Curie temperature heaters, conductor-in-conduit heaters, heater strips, ceramic
15 heaters, resistance wire heaters and resistance ribbon heaters.

The temperature in the vicinity of the attachment of the heat transfer system or plug also can be increased by inducing an alternating magnetic field using the magnetic field generating device to produce inductive heating of the magnetically susceptible particles in the frozen plug, thereby at least partially melting the frozen plug and restoring flow of the
20 fluid through the conduit. In methods that include magnetic induction heating to at least partially melt the frozen plug, the injection slurry composition can include at least some portion of magnetically susceptible particles that have a ferromagnetic coating. The coating can completely envelope the particle, but it is not necessary that the coating does so. In the methods provided herein, the injection slurry composition can include magnetically
25 susceptible particles that include a ferromagnetic coating, and these particles can be injected into the fluid within the conduit after at least a portion of the fluid has begun to form on the walls of the conduit, thereby positioning the ferromagnetic coated magnetically susceptible particles in the interior of the frozen plug of fluid. In some methods, the injection slurry composition can include magnetically susceptible particles that include a ferromagnetic
30 coating, and these particles can be initially injected into the fluid within the conduit, thereby positioning the ferromagnetic coated magnetically susceptible particles in the exterior portion of the frozen plug of fluid. In some methods, the magnetic fields of the magnetic field generating device are adjusted during deposition of the ferromagnetic coated

magnetically susceptible particles so that the particles accumulate along one side of the forming frozen plug. Introduction of alternating magnetic fields to produce magnetic induction heating in the particles, at least partially by virtue of the ferromagnetic coatings on the beads, can result in targeted melting of the frozen plug, producing a channel or path
5 through which the fluid can flow while at least a portion of the plug remains attached to the inner conduit wall.

In the methods provided herein, the fluid within the conduit can include a hydrocarbon gas or a hydrocarbon fluid or a combination thereof. In some instances, the fluid includes petroleum and the conduit is part of a pipeline or an oil well.

10 In the methods provided herein, the magnetically susceptible particles when injected into the fluid within the conduit can cause localized modulation in temperature and viscosity of the fluid within the conduit. The magnetically susceptible particles can be hollow or can be solid, or a combination of hollow and solid particles can be used. The magnetically susceptible particles can have a very broad particle size distribution (*e.g.*, from nanometer
15 sized particles to particles 20 cm in diameter). The magnetically susceptible particles of the methods can have a particle size from about 1 nm to about 100 μm . The magnetically susceptible particles of the methods can have a particle size greater than 100 μm and less than 5 cm. For example, the magnetically susceptible particles used in the methods can have a particle size between about 1000 μm and about 1 cm. The average particle size can
20 have a unimodal, bimodal or polymodal distribution.

The particles used in the methods can have any shape, such as cubes, flakes, granules, cylinders, rings, rods, needles, prisms, disks, fibers, pyramids, spheres, spheroids, prolate spheroids, oblate spheroids, ellipsoids, ovoids, hexahedrons, hexagonal prisms, tetrahedrons, octahedrons, truncated octahedrons, dodecahedrons, triangular prisms or
25 random non-geometric shapes or any combinations of these shapes.

In the methods provided herein, the heat transfer system can include a refrigeration system that contains a compressor, a condenser and a heat exchange unit. The compressor can include a reciprocating compressor, a rotary compressor, a screw compressor, a scroll compressor or a combination of any one of these compressors. The heat transfer system can
30 include a refrigeration system that contains a vapor compression refrigeration system, a heat exchange unit, a magnetic refrigeration unit or a cryogenic cooling system or a combination thereof.

The methods provided herein can be used for temporarily isolating an oil well. Also provided are methods for temporarily preventing the flow of a fluid in a pipeline. Also provided are methods for temporarily preventing flow of a fluid in a production tubing. All of the methods include activating a magneto-cryogenic valve as provided herein attached to the conduit, or activating a system provided herein that includes a magneto-cryogenic valve attached to the conduit.

Other objects, features and advantages of the compositions, systems and methods described herein will become apparent to those skilled in the art from the following detailed description. It is to be understood, however, that the detailed description, while indicating certain embodiments of the devices, systems and methods described herein, are given by way of illustration and not limitation. Many changes and modifications within the scope of the present invention may be made without departing from the spirit thereof.

DETAILED DESCRIPTION

BRIEF DESCRIPTION OF THE FIGURES

The drawings described herein are for illustrative purposes only of selected embodiments and not all possible implementations, and are not intended to limit the scope of the present disclosure.

FIG. 1 is a top view of magneto-cryogenic valve **100** that includes a first injector device **110**, a second injector device **120**, a heat transfer system **130** and a plurality of magnetic field generating devices **140** integrated into a support channel **160** that can be connected to a conduit via connectors **150** and **150'**. The direction of flow is indicated by **F** with an arrow indicating the flow direction.

FIG. 2 is a top view of a magneto-cryogenic valve **100** connected to a conduit, where the support channel **160** of the magneto-cryogenic valve **100** contains a portion that is of a larger diameter than the diameter of the conduit to which it is attached. A beveled or sloped configuration is depicted, which provides a uniform transition from the smaller inner diameter of the conduit to larger inner diameter of the magneto-cryogenic valve chamber. Non-laminar flow will occur at the edges of the valve with some turbulent flow through the valve chamber.

FIG. 3 is a top view of a magneto-cryogenic valve **100** connected to a conduit, where the support channel **160** of the magneto-cryogenic valve **100** is of the same diameter as the diameter of the conduit to which it is attached.

FIG. 4 is an exploded view of a magneto-cryogenic valve segmented into two parts so that it can be attached to a conduit **500** containing a breach **550**. The segments of the support channel **160a** and **160b** of the support channel interconnectedly join to form a contiguous channel that surrounds the breached channel, with end plates that seal the support channel to the breached channel so that no fluid from within the breached channel can escape the assembled portions of the support channel. The segments of the heat transfer unit **130a** and **130b** interconnectedly join to form a contiguous unit surrounding the conduit and in thermal communication with at least a portion thereof.

FIG. 5 is a cross-section view of a magneto-cryogenic valve **100** that includes a first injector device **110**, a second injector device **120**, a heat transfer system **130** and a plurality of magnetic field generating devices **140** integrated into a support channel **160** that can be connected to a conduit via connectors **150** and **150'**. The heat transfer system **130** includes an inlet port **131** connected to an inlet pressure regulator **132**, which is connected to a cryogen supply module via pipe **133**. The heat transfer system **130** also includes an outlet port **135** connected to an outlet pressure regulator **136**, which includes a pressure relief valve **137** and a vent **138**.

FIG. 6A is a cross-section view of a magneto-cryogenic valve illustrating the introduction of magnetically susceptible particles **170** into the valve chamber of the magneto-cryogenic valve **100**.

FIG. 6B is a cross-section view of a magneto-cryogenic valve illustrating the introduction of magnetically susceptible particles **170a**, **170b**, **170c**, **170d**, and **170e** of different sizes into the valve chamber of the magneto-cryogenic valve **100**.

FIG. 7 is a schematic of a system that includes a magneto-cryogenic valve, a cryogen supply module **400** to provide cryogen to a heat transfer system **130**, an adhesion promoter composition supply module **200** to provide an adhesion promoter composition to the first injector device **110**, an injection slurry composition supply module **300** to provide an injection slurry composition containing magnetically susceptible particles to a second injector device **120**, and a plurality of magnetic field generating devices **140** integrated into a support channel **160**.

FIG. 8 is a side view of a heat exchange unit depicting the interconnection of two segments of a heat exchange unit using a connector.

FIG. 9 shows a cross-section of a heat exchange unit of **FIG. 8** depicting the interconnection of two segments of a heat exchange unit using a connector and containing thermally conducting particles.

FIG. 10 is a side view of a magneto-cryogenic valve **100** that includes a first injector device **110**, a second injector device **120**, a heat transfer system that includes an inlet port **131**, cryogenic cooling coils **155** and outlet port **135**, and a plurality of magnetic field generating devices **140** that include an electromagnetic solenoid coil **640** and an electromagnetic core **650**. The valve **100** can be connected to a conduit via connectors **150** and **150'**. The inlet port **131** is shown connected to an inlet pressure regulator **132**, which is connected to a cryogen supply module via pipe **133**. The outlet port **135** is shown connected to an outlet pressure regulator **136**, and a pressure relief valve **137** and a vent **138**.

FIG. 11 is a side view of a magneto-cryogenic valve **100** that includes a plurality of protruding magnetic field generating devices **140** that include an electromagnetic solenoid coil **640** and an electromagnetic core **650**, which is shown attached via an electromagnetic core flange **656**. The valve **100** includes a valve chamber having optional instrument fittings **730**, the first valve chamber segment **620** being connected to an incoming chamber-connecting conduit **670**, which is attached to an incoming pipeline-connecting conduit **660**, which contains a first injector device **110**, a second injector device **120** and optionally instrument fitting **730**. The incoming pipeline-connecting conduit **660** is connected to flange connector **600**, which can be used to attach the valve **100** to a pipeline. The valve **100** includes a second valve chamber segment **621** having optional instrument fittings **730**, the second valve chamber segment being connected to an outgoing chamber-connecting conduit **671**, which is attached to an outgoing pipeline-connecting conduit **661**, which is attached to a flange connector **601**. The first valve chamber segment can be connected to the second valve chamber segment via a plurality of threaded rods **740** and nuts **741** to form a valve chamber.

FIG. 12 is a skewed side view of the magneto-cryogenic valve **100** of Figure 11. In this view the flange bolt holes **610** and the ports **705** to the cooling chambers are visible. The first chamber segment and second chamber segment of the valve chamber also are slightly separated to show the flange bolt holes **720** in the first chamber segment flange **715** and the second chamber segment flange **717** of the valve.

FIG. 13 is a side view of a magneto-cryogenic valve **100** showing the flange bolt holes **610** via which the flange connecter **600** and flange connecter **601** can be connected to a pipeline or adjacent systems.

FIG. 14 is a cross section of a magneto-cryogenic valve **100** showing the first valve chamber segment **620** connected to a second valve chamber segment **621** to form a valve chamber. The figure shows a flange gasket **716** between the first chamber segment flange **715** and the second chamber segment flange **717**. Also shown are the magnetic field generator ends **685**. In the configuration shown, the magnetic field generator ends **685** do not intrude into the valve chamber. Flange bolt holes **610** allow the magneto-cryogenic valve **100** to be connected to adjacent systems.

FIG. 15 is a cross section of a magneto-cryogenic valve **100** showing the first cooling chamber segments **700** adjacent to the first valve chamber segment **620**, and the second cooling chamber segments **701** adjacent to the second valve chamber segment **621**. When the first and second segments are joined, a plurality of cooling chambers in proximity to the valve chamber are formed. Cryogen enters each cooling chamber via a port **705** and exits via a port **706**, (although this could be reversed so that the cryogen enters each cooling chamber via a port **706** and exits via a port **705**).

FIG. 16 is a top view of a magneto-cryogenic valve **100** showing flange bolt holes **720** in the first chamber segment flange **715**, the flange bolt holes **610**, the entry to chamber **800**, the electromagnetic solenoid coils **640** and the electromagnetic cores **650**.

FIG. 17 is a top view of a cross section of a magneto-cryogenic valve **100** having three folds in the valve chamber wall to form a tri-lobed valve chamber configuration. The figure shows the first cooling chamber segments **700** in proximity to the folds **625** in the valve chamber wall, facilitating thermal transfer from the valve chamber to the cryogen flowing through the cooling chambers. Also shown are magnetic field generator ports **680**, the electromagnetic solenoid coils **640**, the electromagnetic cores **650**, and valve chamber exit **801**.

FIG. 18 is a top view of a cross section of a magneto-cryogenic valve **100** having no folds in the valve chamber wall, forming an essentially cylindrical valve chamber. Also shown are magnetic field generator ports **680**, valve chamber bolt holes **710**, and valve chamber exit **801**.

FIG. 19A is a top view of a cross section of a magneto-cryogenic valve **100** having two folds in the valve chamber wall to form a bi-lobed valve chamber configuration. The

figure shows the cooling chamber segments **700** in proximity to the folds **625** in the valve chamber wall, facilitating thermal transfer from the valve chamber to the cryogen flowing through the cooling chambers. Also shown are magnetic field generator ports **680**, and valve chamber exit **801**.

5 **FIG. 19B** is a skewed top view of a cross section of the magneto-cryogenic valve **100** of Fig. 19A.

FIG. 20 is a cross section of a magneto-cryogenic valve **100** having two folds in the valve chamber wall to form a bi-lobed valve chamber configuration, containing two cooling chambers.

10 **FIG. 21A** is a top view of a cross section of a magneto-cryogenic valve **100** having five folds in the valve chamber wall to form a penta-lobed valve chamber configuration. The figure shows the cooling chamber segments **700** in proximity to the folds **625** in the valve chamber wall, facilitating thermal transfer from the valve chamber to the cryogen flowing through the cooling chambers.

15 **FIG. 21B** is a skewed top view of a cross section of the magneto-cryogenic valve **100** of Fig. 21A.

FIG. 22 is a cross section of a magneto-cryogenic valve **100** having five folds in the valve chamber wall to form a penta-lobed valve chamber configuration, containing five cooling chambers and ten magnetic field generating devices. For sake of clarity, only six of the magnetic field generating ports **680** are shown. For sake of clarity, only one of the cooling chambers is shown.

20 **FIG. 23** is a side view of a magneto-cryogenic valve **100** that includes a plurality of protruding magnetic field generating devices **140** that include an electromagnetic solenoid coil **640** and an electromagnetic core **650**, the devices **140** shown attached via an electromagnetic core flange **656**. The magneto-cryogenic valve **100** includes a valve chamber formed by connecting a first valve chamber segment and a second valve chamber segment. The first valve chamber segment is shown connected to an incoming chamber-connecting conduit **670**, which is attached to an incoming pipeline-connecting conduit **660**, which contains a first injector device **110** and a second injector device **120**. The incoming pipeline-connecting conduit **660** is connected to flange connector **600** containing flange bolts holes **610**, which can be used to attach the valve **100** to a pipeline. The second valve chamber segment can be connected to an outgoing chamber-connecting conduit **671**, which is attached to an outgoing pipeline-connecting conduit **661**, which is attached to a flange

25

30

connector **601** containing flange bolts holes **610**, which can be used to attach the valve **100** to a pipeline.

FIG. 24 is a cross section of a magneto-cryogenic valve **100** showing the first valve chamber segment **620** connected to a second valve chamber segment **621** to form a valve chamber. The figure shows a flange gasket **716** between the first valve chamber segment flange **715** and the second valve chamber segment flange **717**. Also shown are the electromagnetic core ends **655**. In the configuration shown, the electromagnetic core ends **655** are within the valve chamber.

FIG. 25 is a cross section of a magneto-cryogenic valve **100** showing a valve chamber that does not have symmetrical end walls. The valve chamber shown has no folds and is essentially cylindrical. In the configuration shown, the first valve chamber segment **620** has a flat chamber wall **805** while the second valve chamber segment **621** has a sloped chamber wall **810**. Four independent magnetic field generating devices **140** are shown, as is one magnetic field generator end **685**.

FIG. 26 is a side view of a magneto-cryogenic valve **100** containing a penta-lobed valve chamber and twenty separate magnetic field generator devices **140** (only twelve of which are shown in the figure).

FIG. 27 is a cross section of a magneto-cryogenic valve **100** showing the first valve chamber segment **620** connected to a second valve chamber segment **621** to form a valve chamber. The figure shows a flange gasket **716** between the first valve chamber segment flange **715** and the second valve chamber segment flange **717**. Also shown are the magnetic field generator ends **685**. In the configuration shown, the magnetic field generator ends **685** are within the valve chamber. For sake of clarity, only one of the cooling chambers is shown, formed by the connection of the first cooling chamber segment **700** to the second cooling chamber segment **701**.

FIG. 28 is a cross section of a magneto-cryogenic valve **100** showing a valve chamber that has symmetrical end walls. The valve chamber shown has no folds and is essentially cylindrical. In the configuration shown, each of the first valve chamber segment **620** and the second valve chamber segment **621** has a sloped chamber wall **810**. Eight independent magnetic field generating devices **140** are shown.

FIG. 29 is a cross section of a magneto-cryogenic valve **100** showing a valve chamber that has symmetrical end walls. The valve chamber shown has no folds and is essentially cylindrical. In the configuration shown, each of the first valve chamber segment

620 and the second valve chamber segment 621 has a flat chamber wall 805. Four independent magnetic field generating devices 140 are shown.

Corresponding reference numerals indicate corresponding parts throughout the several views of the drawings. For parts which are similar but not the same as parts
5 originally specified with a given number, a prime (') of the original number(s) is used.

The drawings in the present application and their accompanying detailed description are directed to merely exemplary implementations. The drawings are generally not to scale, some of the dimensions are for the clarity of presentation and are shown exaggerated in the drawings, and are not intended to correspond to actual relative dimensions. Certain
10 elements in some of the figures may be omitted, or illustrated not to scale, for illustrative clarity. The cross-sectional views may be in the form of “slices”, or “near-sighted” cross-sectional views, omitting certain background lines which would otherwise be visible in a “true” cross-sectional view, for illustrative clarity. Further, only those elements which are useful to the understanding of the present invention have been shown and described.
15 Although the views in the drawings for ease of description generally show similar orientations, this depiction in the drawings is arbitrary for the most part and the device could be illustrated and operated in any orientation.

A. Definitions

Unless defined otherwise, all technical and scientific terms used herein have the same
20 meaning as is commonly understood by one of skill in the art to which the inventions belong.

All patents, patent applications, published applications and publications, websites and other published materials referred to throughout the entire disclosure herein, unless noted otherwise, are incorporated by reference in their entirety. In the event that there are a plurality of definitions for terms herein, those in this section prevail. Where reference is made to a
25 URL or other such identifier or address, it is understood that such identifiers can change and particular information on the internet can come and go, but equivalent information can be found by searching the internet. Reference thereto evidences the availability and public dissemination of such information.

As used here, the singular forms “a,” “an” and “the” include plural referents unless
30 the context clearly dictates otherwise.

As used herein, ranges and amounts can be expressed as “about” a particular value or range. “About” also includes the exact amount. Hence “about 5 percent” means “about

5 percent” and also “5 percent.” “About” means within typical experimental error for the application or purpose intended.

As used herein, “optional” or “optionally” means that the subsequently described element, event or circumstance does or does not occur, and that the description includes
5 instances where the element, event or circumstance occurs and instances where it does not. For example, an optional component in a system means that the component may be present or may not be present in the system.

In the examples, and throughout this disclosure, all parts and percentages are by weight (wt%) and all temperatures are in °C, unless otherwise indicated.

10 As used herein, the phrase “based on the weight of the composition” with reference to % refers to wt% (mass% or (w/w)%).

As used herein, “particle” refers to a small mass that can be composed of any material, such as a metal, *e.g.*, thermally conductive metals, and can be of any shape, including cubes, flakes, granules, cylinders, rings, rods, needles, prisms, disks, fibers,
15 pyramids, spheres, spheroids, prolate spheroids, oblate spheroids, ellipsoids, ovoids, hexahedrons, hexagonal prisms, tetrahedrons, octahedrons, truncated octahedrons, dodecahedrons, triangular prisms or random non-geometric shapes or any combinations of these shapes. The particles can be isotropic or anisotropic.

As used herein, “diameter” refers to the length of a straight line through the center of
20 an object, and such as the measurement of width or length of an anisotropic particle. As used throughout the specification, diameter refers to D90 diameter, which means that 90% of the particles have a diameter of this value or less.

As used herein, “specific surface area” is defined as the ratio of the total particle surface area versus the total particle volume.

25 As used herein, a “conduit” is a channel, tube, duct or pipe for conveying fluids.

As used herein, “fluid” refers to gases, liquids, supercritical fluids and materials that flow, optionally containing dissolved species, solvated species and/or particulate matter. Fluids also refer to multiple fluids of different types present together. In this context, fluid refers to any form of liquid or pumpable material such as gas, petroleum, drill fluid, cement,
30 concrete or resin coated sand.

As used herein, “thermal energy” refers to power that produces heat.

As used herein, “thermal communication” refers to heat transfer between bodies that are in contact or that are integrally connected by a medium that transmits thermal energy.

Such communication generally involves radiation, conduction, convection or a combination thereof. Thermal communication may involve fluid communication (*e.g.*, convection or conduction) or may not involve fluid communication (*e.g.*, radiation).

As used herein, “thermal contact” refers to an arrangement that provides good thermal communication from one surface to another and does not necessarily denote the absence of an intermediate layer between the two surfaces. The terms “thermal contact” includes any coupling between one component and another component that enables relatively efficient transfer of heat between the components. The components can be directly thermally contacted with each other, or they may be indirectly contacted (such as through a thermally conductive layer, block or conduit).

As used herein, “thermal transfer” refers to conveying thermal energy by one object to another.

As used herein, “fluid communication” refers to communication that involves the transfer of a fluid.

As used herein, “cooling rate” refers to how fast thermal energy is removed from an object. A value for cooling rate can be obtained by dividing the difference between the temperature at which cooling is started and the final cooling temperature by the time for reaching the final cooling temperature from the start of cooling. Generally, cooling rate refers to the decrease in temperature of an object over time. The cooling rate can be adjusted by control of the rate at which thermal energy is removed from the object. The details of heat exchange are well known to those in the art.

As used herein, “cryogen” refers to any substance having a boiling point below -40°C . Exemplary cryogens include liquid nitrogen, liquid nitrous oxide, liquid methane, liquid natural gas, or liquid or solid carbon dioxide, chlorodifluoro-methane, or Freon[®], or any number of other refrigerants or fluids with a high thermal energy transfer capacity and low boiling point, as are commonly known to those skilled in the art. Cryogens can readily induce a temperature differential when applied to an object.

As used herein, “cryogen liquid” refers to a cryogenic fluid in liquid phase. In some instances, cryogenic liquids are liquefied gases that have a normal boiling point below -238°F (-150°C). For example, liquid argon has a boiling point of -302.6°F (-185.9°C) and liquid nitrogen has a boiling point of -321°F (-196°C).

As used herein, the term “cryogenic” refers to cooling media that are used at a temperature of -40°C or colder.

As used herein, “thermally conductive” refers to the property of a material to transfer or pass thermal energy or heat to another material or through itself. Thus, a thermally conductive material readily transfers thermal energy, either by conduction, convection or radiation, to another material or through itself.

5 As used herein, “thermally non-conductive” refers to the inability of a material to transfer or pass thermal energy or heat to another material or through itself and thus is a thermally insulating material.

As used herein, “thermal conductivity,” λ_1 , is defined as the quantity of heat transmitted, due to a temperature gradient, in unit time under steady conditions in a direction
10 normal to a surface of unit area. Devices for measuring thermal conductivity are well known in the art (*e.g.*, U.S. Pat. No. 4,283,935).

As used herein, “refrigeration” refers to the removal of heat from an object or fluid.

As used herein, “refrigerant” refers to any heat transfer medium, particularly a fluid medium, that is suitable for cooling applications. A refrigerant can be a cryogenic fluid in
15 liquid phase, such as liquid argon or liquid nitrogen.

As used herein, “crude oil” or “petroleum” refers to oil recovered from below the earth’s surface and that remains untreated or unrefined. Crude oil generally contains a mixture mainly of pentanes and heavier hydrocarbons that may be contaminated with sulphur compounds, is recovered or recoverable at a well from an underground reservoir,
20 and generally is liquid at the conditions under which its volume is measured or estimated. Crude oil is referred to as “heavy” if its density is 900 kg/m^3 or greater, and is referred to as “light” or “conventional” if it has a density of less than 900 kg/m^3 .

As used herein, “surface active agent” refers to a chemical, particularly an organic chemical, that when added to a liquid changes the properties of that liquid at a surface. The
25 liquid can be any fluid.

As used herein, “surfactant” refers to surface active agent molecules that absorb at the air/water, oil/water and/or oil/water interfaces, substantially reducing their surface energy. The term “detergent” is often used interchangeably with the term “surfactant.”
30 Surfactants generally are classified depending on the charge of the surface active moiety, and can be categorized as cationic, anionic, nonionic and amphoteric surfactants.

As used herein, “silicone surfactant” refers to a surface active agent that includes at least one Si atom.

As used herein, “magnet” refers to a material or an article that may spontaneously or actively generate magnetic fields, where the strength of the magnetic fields can be measured by a conventional gaussmeter. A magnet can be a permanent magnet or an electromagnet.

As used herein, “magnetic” refers to a property of a material that may be able to
5 spontaneously or actively generate magnetic fields.

As used herein, “permanent magnet” refers to any object that is magnetized and creates its own persistent magnetic field. Suitable ferromagnetic materials for a permanent magnet include iron, nickel, cobalt, rare earth metals and their alloys. The term “permanent” does not mean such a magnet could not lose its magnetism, for example,
10 through exposure to heat, physical shock, or an opposing magnetic field.

As used herein, “electromagnet” refers to any device that is capable of creating a magnetic field through the application of electrical energy. Electromagnets can include a core and a coil or other element for carrying current to generate magnetic fields.

As used herein, “diamagnetic” refers to a material with a magnetic susceptibility less
15 than 0 and particles of the material cause a weakening of magnetic induction relative to an applied magnetic field.

As used herein, “paramagnetic” refers to a material with a magnetic susceptibility greater than 0 and particles of the material cause a strengthening of magnetic induction relative to an applied magnetic field.

Neither a “paramagnetic” nor “diamagnetic” material may spontaneously or actively
20 generate a magnetic field and thus are referred to as “non-magnetic” material.

As used herein, “ferromagnetic” refers to a material with a magnetic permeability very much greater than 1 and that exhibits non-linear, hysteretic behavior between magnetic induction and an applied magnetic field. Ferromagnetic materials often have their atoms
25 arranged in a lattice with their magnetic moments aligned parallel to each other. Examples of ferromagnetic material include cobalt, iron and nickel.

As used herein, “ferrite” refers to a material that exhibits ferromagnetism. Ferromagnetism is a property exhibited by certain metals, alloys, and compounds of the transition (iron group) rare earth and actinide elements, in which the internal magnetic
30 moments spontaneously organize in a common direction; ferromagnetism gives rise to a permeability considerably greater than that of vacuum and to magnetic hysteresis. *See, e.g.*, page 706 of Sybil B. Parker’s “McGraw-Hill Dictionary of Scientific and Technical Terms,” (4th ed., McGraw-Hill Book Company, New York, N.Y., 1989).

As used herein, “magnetic permeability” refers to a property of a substance of retaining magnetic field lines and has a dimension of Tesla meter/ampere or Newton/ampere². The terms “relative magnetic permeability” and “relative permeability” refer to a ratio of the “magnetic permeability” of a substance of interest to that of air and, therefore, are dimensionless properties.

As used herein, “magnetic susceptibility” refers to a difference between the “relative permeability” and 1. The “magnetic susceptibilities” of the ferromagnetic materials are far greater than 0, while those of the paramagnetic and diamagnetic materials may only be slightly greater and less than 0, respectively.

As used herein, “magnetically susceptible particles” refers to particles that interact with a magnetic field. In some instances, the magnetically susceptible particles are attracted to a magnetic field.

As used herein, “in the vicinity of” refers to any location adjacent to or within the proximity of the stated location.

As used herein, “cryogenic cooling coils” refers to tubing or piping suitable for use with cryogens configured in a coil about a central structure, whereby when a cryogen is flowed through the coils, thermal energy is extracted from the central structure and transferred to the cooling coils, reducing the thermal energy of the central structure.

B. MAGNETO-CRYOGENIC VALVES

Provided herein are magneto-cryogenic valves for reversibly modulating flow of a fluid through a conduit. The magneto-cryogenic valves include a heat transfer system that is in thermal communication with at least a portion of the conduit, one or more injectors for injecting a material into the fluid from the conduit, and a magnetic field generating device that emits magnetic fields that can interact with magnetically susceptible particles injected into the fluid through one or more of the injectors. In some applications, the magneto-cryogenic valves include at least one injector device for injecting into the fluid from the conduit an injection slurry containing magnetically susceptible particles, and at least one injector device for injecting an adhesion promoter composition into the fluid from the conduit.

The magneto-cryogenic valve can include a chamber into which the fluid from the conduit flows and into which the magnetic fields of the magnetic field generating device(s) can be directed, positioning the magnetically susceptible particles within the chamber. The number and configuration of the magnetic field generating devices can be varied in order to

produce a magnetic field in the center of the chamber, or away from the center of the chamber, or to create a plurality of magnetic field zones within the chamber. The chamber can be located in close proximity to the heat exchange unit in order to enhance transfer of thermal energy out of the chamber.

5 The width of the chamber can be varied and be proportional in scale to the inlet pipe size, *e.g.*, the inner diameter of the conduit to which the magneto-cryogenic valve is connected. In some instances, the width of the chamber will be at least 1×, at least 1.5×, at least 2×, at least 2.5×, at least 3×, at least 3.5×, at least 4×, at least 4.5×, at least 5×, at least 5.5×, at least 6×, at least 6.5×, at least 7×, at least 7.5×, at least 8×, at least 8.5×, at least 9×,
10 at least 9.5× or at least 10× the inlet pipe inner diameter. For example, a chamber for use with an inlet pipe having a 2 inch inner diameter can be about 6 inches in diameter, which would be about 3× the inner diameter of the inlet pipe. The width of chamber generally will not be less than 1× the inner diameter of the inlet pipe, so that the chamber would not interfere with the ability of equipment such as pipeline cleaning pigs, monitors or other
15 movable inline inspection devices to traverse the chamber unimpeded.

 The length of the chamber can be varied and be proportional in scale to the inlet pipe size, *e.g.*, the inner diameter of the conduit to which the magneto-cryogenic valve is connected. Generally, a pipe with a larger diameter would be expected to perform better with a chamber of a longer length. In some instances, the length of the chamber will be at
20 least 1.5×, at least 2×, at least 2.5×, at least 3×, at least 3.5×, at least 4×, at least 4.5×, at least 5×, at least 5.5×, at least 6×, at least 6.5×, at least 7×, at least 7.5×, at least 8×, at least 8.5×, at least 9×, at least 9.5× or at least 10× the inlet pipe inner diameter. For example, a chamber for use with an inlet pipe having a 2 inch inner diameter can be about 8 inches in length, which would be about 4× the inner diameter of the inlet pipe.

25 The chamber can be configured to have any desired inner geometry. The chamber can be symmetric or asymmetric. In some instances, the chamber has a smooth, essentially circular chamber diameter resulting in a cylindrical sidewall geometry, as is shown in **FIGS. 4, 5, 6A, 6B, and 18**. As can be seen in **FIG. 18**, the zero-fold design of the chamber contains only a single symmetrical compartment. Ports **680** for the magnetic field generator
30 are shown located opposite each other.

 The chamber also can include one or more folds to modify the surface area of the chamber. The folds can be inward (the chamber wall being pulled toward the center of the

chamber) or outward (the chamber wall being away from the center of the chamber) or a combination thereof. For example, the chamber can include one inward fold, resulting in a chamber having a kidney shape. The chamber can include 2 or more folds. For example, a chamber containing two folds is shown in **FIGS. 19A and 19B**. A chamber containing three folds is shown in **FIG. 17**. When the first valve chamber segment, shown in **FIG. 16**, is attached to the second valve chamber segment, shown in **FIG. 17**, such as by bolts through bolt holes **720**, a tri-lobed chamber is formed, with cooling chambers between two folds **625**. A magneto-cryogenic valve containing a three-lobed chamber is shown in **FIG. 23**. As can be seen in the figure, the magneto-cryogenic valve includes three electromagnets as magnetic field generating devices **140**, each having an electromagnetic solenoid coil **640** and an electromagnetic core **650**. Ports **706** from each cooling chamber can be seen. Each cooling chamber is located within two lobes of the valve chamber, and each electromagnet is located at the apex of each lobe of the chamber.

A chamber containing five folds is shown in **FIGS. 21A, 21B and 22**. The folds in the chamber enhance the transfer of thermal energy out of the material in the chamber to the heat exchange unit(s). The folds in the chamber also enhance the particle loading characteristics of the plug formed within the chamber. Any number of folds can be included in the chamber, *e.g.*, at least 2, 3, 4, 5, 6, 7, 8, 9, 10, 11, 12, 13, 14, 15, 16, 17, 18, 19 or 20 folds. The side walls of the chamber can be of any geometry. In some instances, the walls are smooth. In some instances, the side walls can include etching, projections or indentations or combinations thereof. These can be configured to promote granular loading in the chamber during formation of the plug.

FIG. 22 is a cross section of a magneto-cryogenic valve **100** having five folds in the valve chamber wall to form a penta-lobed valve chamber configuration. The magneto-cryogenic valve contains five cooling chambers, each of which is located between the lobes of the chamber. The magneto-cryogenic valve as shown has ten magnetic field generating devices, which are located near the apex of each lobe of the chamber in the configuration shown. For sake of clarity, only six of the magnetic field generating ports **680** are shown. For sake of clarity, only one of the cooling chambers is shown.

Folded or lobed chambers can be configured so that one or more magnetic field generating devices are located at or near each fold of the chamber. The folded chambers also can be configured to include a heat exchange device between each fold of the chamber. For example, as shown in **FIGS. 19A and 19B**, for a two-fold or bi-lobed chamber, magnetic

field generator ports **680** are located at the apex of each lobe, and cooling chambers **700** are located between each fold. As shown in **FIG. 17**, for a three-fold or tri-lobed chamber, magnetic field generator ports **680** are located at the apex of each lobe, and cooling chambers **700** are located between each fold. As shown in **FIGS. 21A** and **21B**, for a five-fold or penta-lobed chamber, magnetic field generator ports **680** are located at the apex of each lobe, and cooling chambers **700** are located between each fold.

The end walls of the chamber (the entry and exit walls of the chamber) can be of any geometry and can be the same or different. A chamber having two 90° (flat) end walls is shown in **FIG. 29**. A chamber having two 45° (sloped) end walls is shown in **FIG. 28**. A chamber having one 90° (flat) end wall and one 45° (sloped) end wall is shown in **FIG. 25**. Although the figures illustrate sloped end walls having approximately a 45° angle, the size and the angle of the end walls can be adjusted and can be of any angle including negative angles. The end walls also can be of a compound geometry, such as sloping for a distance away from the inlet or outlet pipe, then having a drop-off to the inner wall of the chamber. In some applications, the end walls can have a stepped configuration from the inlet or outlet pipe to the inner wall of the chamber. The size, shape and configuration of the end walls can modulate the flow within the chamber, and can be adjusted to promote granular bed formation:

The chamber of the magneto-cryogenic valve can be one piece, such as a pipeline fitted to the inlet pipeline and outlet pipeline with the appropriate fittings for example, see **FIG. 3**. The chamber of the magneto-cryogenic valve can include several interconnecting pieces to form the chamber. For example, the chamber can include two segments connected together. For example, **FIG. 12** shows a magneto-cryogenic valve that includes two chamber segments, where the first chamber segment has a flange **715** and the second chamber segment has a flange **717**, and the two chamber segments can be joined together using bolts and nuts via flange bolts holes **720**. The chamber segments can be joined together using any technique known in the art. For example, the chamber segments can be joined together using nuts and bolts, welding, screws, rivet bolts, a bayonet fitting, interlocking tabs or any combination thereof. When using nuts and bolts to join the chamber together, the number of bolts used to join the flanges can be determined based on the design of the chamber and the internal valve pressures expected to be experienced by the valve.

The valve chamber can have smooth walls. The valve chamber can include at least one wall that is ridged, fluted, grooved, furrowed, crinkled, puckered, creased or wrinkled or

any combination thereof. The valve chamber walls can include etching, projections or indentations or combinations thereof.

The magneto-cryogenic valve modulates the flow of a fluid through a conduit by forming a reversible plug by removing thermal energy from the fluid within the conduit, resulting in the formation of a frozen plug of fluid that adheres to the inner wall of the conduit or valve chamber, thereby stopping flow of fluid through the conduit. The adhesion of the frozen plug to the inner conduit wall or valve chamber can be increased by introducing an adhesion promoter composition into the fluid via one or more of the injectors. The frozen plug adheres to the inner surface of the conduit with sufficient adherence to withstand the hydraulic pressure of the fluid, stopping the flow of the fluid within the conduit. In some applications, the magnetic field can be configured so that the magnetically susceptible particles are entrapped within the magnetic field in any desired region within the valve chamber, or in multiple regions within the valve chamber. In some applications, the magnetic fields can be positioned so that the magnetically susceptible particles are directed to the center of the valve chamber, or to one end of the valve chamber, or to the walls of the valve chamber, or any combination thereof. The frozen plug that forms adheres to the inner wall of the conduit or valve chamber. The plug containing a packed granular bed of magnetically susceptible particles transfer the upstream pressure load from the fluid in the conduit to the walls of the valve chamber in the magneto-cryogenic valve, which stops the flow of fluid through the magneto-cryogenic valve and helps to maintain plug integrity.

An exemplary magneto-cryogenic valve is depicted in **FIG. 1**. **FIG. 1** is a top view of magneto-cryogenic valve **100** that includes a first injector device **110**, a second injector device **120**, a heat transfer system **130** and a plurality of magnetic field generating devices **140** integrated into a support channel **160** that can be connected to a conduit via connectors **150** and **150'**. The direction of flow is indicated by **F** with an arrow indicating the flow direction. The configuration of the magnetic field generating devices is in a quadropole configuration, but other configurations can be used. With the quadropole configuration of the magnetic field generating devices, the magnetic field in the center is very low and can be zero, and the magnetic field increases as one moves away from the center. This configuration can be used to direct the magnetically susceptible particles in the fluid toward the walls of the conduit, since the magnetic field would be much greater toward the inner surface of the conduit than in the center of the conduit. Other configurations can be used so

- 30 -

that the magnetic fields direct the magnetically susceptible particles to the center of the valve chamber, or to one end of the valve chamber, or to the walls of the valve chamber, or any combination thereof. The first injector device **110** can be used to inject an adhesion promoter composition into the fluid of the conduit. As shown in **FIG. 1**, the first injector device **110** can be positioned some distance from the second injector device **120** to allow the adhesion promoter composition to be mixed with the fluid flowing through the conduit or valve chamber.

The heat transfer system of the magneto-cryogenic valve can be adapted to fit to the surface of at least a portion of a conduit with sufficient thermal intimacy that thermal energy can be transferred between the conduit and the heat transfer system. Any device that can transfer thermal energy between two surfaces can be used as a heat transfer system. In the magneto-cryogenic valves provided herein, a heat sink for transfer of thermal energy away from the conduit and the fluid therein can be used. Hence, the heat transfer system can include a refrigeration system to provide a differential in temperature so that thermal energy moves out of the fluid of the conduit and into the heat transfer system. Examples of refrigeration systems that can be used to reduce the temperature of, or impart negative thermal energy to, the heat transfer system include vapor compression refrigeration systems, especially with a single stage or rotary compressor, heat exchange units, electric thermal transfer devices and cryogenic cooling and absorption systems.

The heat transfer system can be attached to the conduit in a permanent or a detachable configuration. The heat transfer system can include an annular chamber affixed around the conduit to form a cooling zone through which thermal energy is extracted from the conduit and the fluid therein. An exemplary heat transfer system is shown in **FIG. 8**. The heat transfer system is a cryogen cooled system. It can be a single continuous apparatus that encircles or envelops the conduit or can comprise 2, 3, 4 or more interconnecting segments, such as arcs, that when assembled and interconnected, substantially or completely encircle or envelop the outer diameter of the conduit (two interconnecting segments are shown **FIG. 8**). When the conduit is a pipe with a circular shape, the heat exchange unit can be a single complete circular apparatus, two interconnection semi-circular segments or include several arc segments that when connected or interconnected encircle the pipe. The heat transfer system can include an inlet port **131** for accepting cryogen into the heat transfer system and an outlet port **135** for discharging cryogen from the heat transfer system. In some applications, the heat transfer system can

include a thermal conductor surface containing a thermally conducting material and positioned at the interface between the heat transfer system and the conduit.

As shown in **FIG. 8**, the outlet port **135** of one segment of the heat transfer system is configured to be directly connected to the inlet port **131** of another segment of the heat transfer system. As shown, outlet port **135** of one segment of the heat transfer system can be configured to be connected to the inlet port **131** of another segment of the heat transfer system via a connector **134**, such as tubing or piping. In some embodiments, a quick-connect connection can be included on each of inlet port **131** and outlet port **135** to allow for quick set up or replacement of segments of the heat transfer system or one or more heat transfer systems. Quick connect mechanisms are well known in the art (*e.g.*, see U.S. Pat. No. 4,597,699). In the devices, systems and methods provided herein, the length of the heat exchange unit can vary and can be designed by one skilled in the art to be of any length. Because of the injection of the magnetically susceptible particles and, *e.g.*, their concentration near the inner wall of the conduit in the vicinity of the heat transfer device, the length of the heat exchange unit can be dramatically reduced, thereby reducing the amount of cryogen necessary to initiate and maintain a frozen plug of fluid within the conduit or valve chamber.

FIG. 9 shows a cross-section of an exemplary cryogen cooled heat transfer system. The heat transfer system includes a space **139** to accommodate the conduit to which it is to be attached and to be in thermal communication therewith. Segments of pipe are assembled to form an outer casing and to envelop at least a portion of the conduit from which thermal energy is to be extracted. The outer wall of the conduit can serve as the inner wall of the heat transfer system, defining a cooling chamber within the heat transfer system when assembled around the conduit. Steel plates having an opening through which the conduit can pass are welded at each end of the outer casing and around conduit. With the steel plates welded in place, a sealed tube with a cavity between the conduit and the outer casing is formed, with the conduit protruding from each end. The cavity formed can be filled (partially or completely) with particles of a thermally conductive metal **145** and the heat transfer system can be coated with an insulator **146** to thermally isolate the heat transfer system from the environment. As shown, outlet port **135** of one segment of the heat transfer system can be configured to be connected to the inlet port **131** of another segment of the heat transfer system via a connector **134**, such as tubing or piping.

Alternative heat transfer systems can be used. For example, **FIG. 10** shows a magneto-cryogenic valve **100** that includes, as a heat transfer system, cryogenic cooling coils **155**. The cryogenic cooling coils **155** include an inlet port **131**, that can be connected to an inlet pressure regulator **132**, which is connected to a cryogen supply module via pipe **133**. The cryogenic cooling coils **155** also include an outlet port **135** connected to an outlet pressure regulator **136**, and a pressure relief valve **137** and a vent **138**. The cryogenic cooling coils can be wrapped around the valve chamber of the magneto-cryogenic valve to extract thermal energy.

As another example, **FIG. 15** shows a magneto-cryogenic valve **100** that includes, as a heat transfer system, a plurality of cooling chambers positioned near the wall(s) of the valve chamber. The cooling chambers can be engineered to be integrated into the valve. The cooling chambers can be formed by joining two or more cooling chamber segments. A cryogen can flow through the cooling chamber in order to remove thermal energy from the valve chamber. **FIG. 20** shows a magneto-cryogenic valve **100** that includes two cooling chambers, made up of a first cooling chamber segment **700** and a second cooling chamber segment **701**. A heat transfer system can include one or a plurality of cooling chambers, alone or in combination with additional heat transfer systems, such as cryogenic cooling coils.

The cooling chamber can have smooth walls. The cooling chamber can have at least one wall that can be ridged, fluted, grooved, furrowed, crinkled, puckered, creased or wrinkled, such as to increase the surface area of the cooling chamber, such as is shown in **FIG. 27**. The cooling chamber can contain or be filled with particles, filings, turnings, shavings, pellets, threads or beads of a thermally conductive material. The cooling chamber can contain baffles or fins.

When more than one cooling chamber is present, the cooling chambers can be interconnected, or each cooling chamber can be connected to its own source of cryogen. The cryogen can be a liquid that boils at a temperature colder than -40°C , or colder than -100°C , or colder than -110°C , or colder than -120°C , or colder than -130°C , or colder than -140°C , or colder than -150°C , or colder than -160°C . Exemplary cryogens include liquid nitrogen, liquid oxygen, liquid helium, liquid neon, liquid methane, liquid natural gas, liquid argon, liquid nitrous oxide, liquid carbon dioxide, liquid Freon[®] or combinations thereof.

The heat transfer system can be attached directly or indirectly to at least a portion of the conduit from which thermal energy is to be extracted, so long as it is in thermal

communication with at least a portion of the conduit. In some embodiments, the heat exchange unit includes a thermal conducting surface at the interface between the heat transfer system and the conduit, and can enhance thermal energy transfer between the conduit and the heat transfer system. In some embodiments, the heat transfer system is
5 integrated adjacent to or in proximity to the valve chamber.

The magneto-cryogenic valves provided herein increase the rate of transfer of thermal energy from the fluid of the conduit to the wall of the conduit or valve chamber to which a heat transfer system of the magneto-cryogenic valve is attached and thus to the heat transfer system. This is accomplished, at least in part, by use of magnetic fields generated
10 by the magnetic field generating device of the valve to attract and hold magnetically susceptible particles in an injection slurry injected into the fluid within the conduit via an injector of the valve in close proximity to the inner wall of the conduit. The heat transfer system removes the thermal energy from at least a portion of the conduit or valve chamber and the fluid therein, particularly at the area of attachment of the heat transfer system.

The magnetically susceptible particles of the slurry can be selected to have a higher
15 thermal conductivity than the thermal conductivity of the fluid. The magnetically susceptible particles of the slurry are cooled to a temperature below the freezing temperature of the fluid of the conduit. When the injection slurry containing the cooled magnetically susceptible particles is injected into the fluid of the conduit via an injector of
20 the magneto-cryogenic valve, the slurry imparts negative thermal energy into the fluid, reducing the temperature of the fluid. The magnetic field generating device of the magneto-cryovalve can be activated, and the magnetic fields interact with the magnetically susceptible particles of the slurry. By modulating the magnetic flux of the magnetic field generating device, the magnetically susceptible particles of the slurry can be positioned
25 within the conduit or valve chamber, such as to the inner surface of the conduit so that they are in thermal communication with at least a portion of the conduit or valve chamber. In some applications, the magnetic field generating device is positioned on one or both sides of the heat transfer system that is in thermal communication with at least a portion of the conduit, and the magnetically susceptible particles facilitate thermal energy transfer from
30 the fluid within the conduit to the heat transfer system for removal.

By manipulating the magnetic field generating device, a uniform magnetic flux density can be created through the freeze zone to maintain the distributed magnetically susceptible particles at a location to promote local thermal energy extraction, resulting in

formation of at least a layer of frozen fluid on a portion of one or more magnetically susceptible particles. In some instances, a non-uniform magnetic flux density can be created through the freeze zone to promote directional deposition of the magnetically susceptible particles of the slurry. By manipulating the deposition of the magnetically susceptible particles of the slurry, the magneto-cryogenic valve effectively increases thermal conductance at the inner wall of the conduit or valve chamber when the magnetic field generating device is activated and the injection slurry is introduced into the fluid of the conduit. The thermal conductance is increased because the insulating effect of frozen fluid, having a low thermal conductance, is overcome by the introduction of magnetically susceptible particles having a higher thermal conductance than the frozen fluid, resulting in concentric freezing in a much shorter amount of time than could be accomplished by use of only a heat transfer device.

One of the benefits achieved by effectively increasing the thermal conductance at the inner wall of the conduit or valve chamber is rapid thermal energy transfer out of the fluid of the conduit to the heat transfer system. A result that can be achieved is the reduction in the length of the heat transfer system required for thermal energy transfer. Thus, the overall length of the device can be reduced while still removing sufficient thermal energy from the fluid to produce a frozen plug of fluid attached to the inner wall of the conduit or valve chamber, the plug having sufficient strength to withstand the hydraulic pressure of the flowing fluid within the conduit to stop the flow of fluid. Thus, the magneto-cryogenic valves, systems and methods provided herein result in fast and efficient plug formation, overcoming problems described in the art. For example, U.S. Pat. No. 5,125,427 teaches that forming a plug in a pipeline by freezing requires an excessive amount of cooling to form the plug, stating that many hours or even days are required to form a plug of water in large diameter lines. These prior art techniques lacked an effective heat sink for efficient heat transfer from the flowing fluid to the heat sink. The magneto-cryogenic valves, systems and methods described herein include an efficient heat sink for effective heat transfer from a flowing fluid in a conduit, resulting in rapid formation of a frozen plug of fluid.

The magneto-cryogenic valves as described herein can be a permanent attachment on a conduit or can be an attachable device that can be affixed to a conduit, such as to serve as an emergency flow prevention device. The magneto-cryogenic valves provided herein can be integrated in a well line, such as an oil well or gas line, for reversible plugging of the

line. The magneto-cryogenic valves can be attached directly or indirectly to any part of the casing or well head of the well. In normal fluid recovery processes from a well, the magneto-cryogenic valve is not active and is not removing thermal energy from the fluid or the conduit nor is it injecting material into a fluid within the conduit and the magneto-cryogenic valve serves as a conduit for the fluid flow. When it is desirable to stop the flow of the material through the conduit, the magneto-cryogenic valve can be activated to freeze at least a portion of the material flowing inside the conduit or valve chamber, forming a reversible frozen plug of material that can stop the flow of material through the conduit. Activation includes charging the heat transfer system to serve as a heat sink, activating the magnetic field generating device to produce a magnetic field, and injection of slurry containing magnetically susceptible particles, where the magnetic flux of the magnetic field generating device at least in part attracts the magnetically susceptible particles and directs the magnetically susceptible particles to a desired location within the conduit or valve chamber, *e.g.*, to an inner wall of the conduit or valve chamber.

The magneto-cryogenic valves provided herein addresses limitations of cryogenic freeze pressure isolation technologies known in the art. For example, the magneto-cryogenic valves can be installed in a conduit, having no effect on flow until activated, and once activated, rapidly control the flow of fluid in the conduit. The magneto-cryogenic valves do not require precision machining or other high cost manufacturing techniques. The installed costs of magneto-cryogenic valves are expected to be slightly greater than the surrounding sections of tubular, but insignificant relative to the cost of additional large diameter ball valves or blow-out preventers conventionally used. The magneto-cryogenic valves require very low maintenance, exhibit lower cost than conventional valves, and are capable of being installed above or below-ground or sea applications including deep water applications. Importantly, the magneto-cryogenic valves provided herein are capable of undergoing multiple freeze-thaw cycles and thus can be utilized repeatedly, avoiding the need to replace the valve after activation. The devices and systems provided herein can include features that allow remote activation in under-water, below ground, or sealed-in concrete applications. The devices and systems can be incorporated into well casing and cemented in place at relatively low incremental cost.

The magneto-cryogenic valves provided herein generally are designed so that their injectors do not protrude into the flow channel. Such a design allows installation of the magneto-cryogenic valve without interfering with the equipment often used to transit the

pipelines and conduits internally to monitor and perform maintenance of the interior surface of the pipeline. It is to be understood that the magneto-cryogenic valves can include element that can be positioned into the fluid flow when necessary for monitoring conditions, such as temperature or flow rate. Such elements can be designed so that they can be
5 retracted out of the flow channel when not taking a measurement.

The magneto-cryogenic valves, systems and methods described herein can produce a plug in flowing fluid and do not require additional devices or mechanisms to divert or arrest the flow of fluid in the conduit prior to use of the magneto-cryogenic valves, systems and methods provided herein. Thus, the magneto-cryogenic valves, systems and methods
10 provided herein obviate the need to isolate, divert or stop the flow of fluid within the conduit or flow tubular to form a plug, as required by prior art methods (*e.g.*, see U.S. Pat. No. 4,370,862, which teaches that a plug of ice can be formed in a pipeline if water in the pipeline is maintained in a static condition).

Another advantage of the magneto-cryogenic valves provided herein is the provision
15 of a heat sink and a mechanism for introducing a large amount of negative thermal energy rapidly into the fluid of a conduit. By injecting a slurry containing magnetically susceptible particles at a temperature below the freezing point of the fluid of the conduit and using magnetic fields to position the magnetically susceptible particles within the conduit or valve chamber, *e.g.*, in proximity to the inner wall of the conduit or valve chamber so that they are
20 in thermal communication with at least a portion of the conduit or valve chamber, thermal energy transfer from the fluid to the heat transfer system is improved, significantly reducing the amount of time required to form a frozen plug of fluid. This is significantly different from prior art cryogen methods. For example, U.S. Pat. No. 3,857,255 describes a device for freezing fluid within a pipe by surrounding the pipe with a cryogen. Spraying a cryogen
25 on a warm pipe does not produce an efficient extraction of thermal energy from the pipe. In contrast, the magnetically susceptible particles of a thermally conductive material serve as a very efficient heat sink for the transfer of thermal energy out of the fluid, allowing for formation of a frozen plug of fluid without the need for diverting or arresting the flow of fluid through the conduit.

30 Because of the efficiency of the heat transfer from the fluid in the conduit using the magneto-cryogenic valves provided herein, the size of the heat transfer system can be reduced compared to heat transfer systems described in the art. In instances where a cryogenically cooled heat transfer system is used, this reduction in size can result in a lower

amount of cryogen necessary to cool the heat transfer system. For example, cryogenic liquid could be maintained on-site utilizing pressurized tanks. Cryogenic refrigeration systems also could be used to obviate the need to maintain inventories of liquefied gases.

5 The magneto-cryogenic valves, systems and methods described herein can be positioned to form a plug anywhere within a conduit and are not limited to the well head. For example, a magneto-cryogenic valve can be positioned so that upon activation, a frozen plug is formed within a production tubing string. The magneto-cryogenic valve can be positioned above or even below the oil producing zone, forming a frozen plug that prevents flow of fluid within the conduit.

10 All components of the magneto-cryogenic valves can be fabricated from material that is suitable for use with cryogens. In general, such is relatively unaffected by cold temperatures. Piping, valves, vessels and other components can be designed for the expected pressures and temperatures, such as to industry standards, *e.g.*, specifications promulgated by the American Society of Mechanical Engineers (ASME). The components
15 also can be designed to accommodate the expected pressures of the fluid within the conduit and the expected pressure of the environment at deployment, such as the high pressures present at deep sea locations. For example, the components can be designed to be of a thickness and/or configuration such that they are resistant to deformation, failure or crushing by the pressure of the fluid moving through the conduit or, *e.g.*, the water pressure
20 at sea depths of deep sea drilling. Exemplary materials include steel, high carbon steel, steel containing Cr, Ni or Si, stainless steel, aluminum, copper, or cryogenically compatible polymers, such as fiber-reinforced epoxy composites and ultra-high molecular weight polyethylene, fiberglass, graphite, plastics, carbon fibers and combinations thereof. Additional materials include alloys having a ductile fracture mode higher than steel and a
25 brittle fracture mode lower than steel are known in the art. Exemplary of such alloys include those described in U.S. Pat. Nos. 5,352,304; 6,183,573; 6,212,891; 7,235,212; 7,648,597 and 7,727,463.

When the magneto-cryogenic valves provided herein are attached to a conduit, the heat transfer system is in thermal communication with the conduit that is to be plugged
30 when the system is valve is activated, and the injector device can be positioned so that it can be in communication with the fluid within the conduit when activated. The heat transfer system can be in close proximity to the injector device. The heat transfer system can be separated from the injector device by some distance. One or more magnetic field generating

device(s) can be positioned anywhere with respect to the conduit or chamber as long as the magnetic field generated produces field lines at least a portion of which penetrate through to the fluid flowing through the conduit or valve chamber and interact with the magnetically susceptible particles injected into the fluid. For example, the magnetic field generating
5 device can be positioned so that a north pole of at least one of its magnets is positioned on one side of the heat transfer system and a south pole of at least one of its magnets is positioned on the other side of the heat transfer system. The magnetic field generating device can be positioned so that it is on the side of the heat transfer system that fluid enters the heat transfer system. A plurality of magnetic field generating devices can be used. For
10 example, one magnetic field generating device can be positioned on each side of the heat transfer system.

In some applications, the magneto-cryogenic valve is provided as an attachable device that can be affixed to a conduit. For example, in such a configuration the magneto-cryogenic valve can be positioned and act as an emergency flow prevention device. The
15 magneto-cryogenic valve can be provided in number of interlocking pieces that when assembled envelop the conduit and attach to the conduit. The interlocking pieces can be interconnected and connected to the conduit using any appropriate connecting means known in the art. In some instances, flanges can be used to connect the interlocking pieces to each other, and flanges on the conduit can be used to connect the magneto-cryogenic valve to the
20 conduit. The flange can include any of a protruding rim, edge, rib, or collar, or combination thereof, and means for attachment for attaching the flange on one component to a flange on another component. In some instances, the interlocking pieces can be joined by welding the flange of one piece to the flange of another unit to join the pieces together. In some embodiments, the flange of one piece is joined to a flange of another piece or to the conduit
25 using a connecting means, such as a screw connection, a bolt and nut connection, rivet bolts, a bayonet fitting, interlocking tabs or any combination thereof.

In some applications, an integrated or assembled magneto-cryogenic valve can include an external thread portion that screws into a corresponding inside thread portion of a conduit, such that the valve can be joined to the conduit by screwing the two together.
30 Thread portions can be included on both sides of the magneto-cryogenic valve so that it can be positioned at any point along the conduit, serving as a portion of the conduit through which fluid flows when not activated. In some instances, seals, such as O-rings, can be included to provide a watertight and/or airtight seal. The seals can be made of any material

known in the art that is compatible with the expected temperatures and pressures of operation of the magneto-cryogenic valve.

In instances where the magneto-cryogenic valve is to be an integrated component with the conduit, it can be of any diameter or length. The selection of the diameter and length can be predicated on the dimensions of the conduit to which the valve is to be
5 integrated and the rate of flow of fluid through the conduit. In some instances, the inner diameter of the magneto-cryogenic valve is the same as the inner diameter of the conduit to which it is to be integrated. In such a configuration, fluid should flow through the valve exhibiting no change in fluid dynamics.

10 In some instances, the inner diameter of at least a portion of the magneto-cryogenic valve is larger than the inner diameter of the conduit to which it is to be integrated. In some instances, a beveled or sloped configuration is used to provide a uniform transition from the smaller inner diameter of the conduit to larger inner diameter of the magneto-cryogenic valve. The heat transfer system is in thermal communication with the portion of the
15 magneto-cryogenic valve that is larger than the inner diameter of the conduit to which it is to be integrated. An exemplary resulting configuration is shown in **FIG. 2**.

FIG. 2 illustrates a top view of a magneto-cryogenic valve attached to a conduit. As shown, the support channel **160** of the magneto-cryogenic valve **100** contains a portion that is of a larger diameter than the diameter of the conduit to which it is attached. In such a
20 configuration, fluid dynamics within the magneto-cryogenic valve is not the same as within the rest of the conduit. A beveled or sloped configuration is depicted, which means that an angled connection connects the smaller diameter of support channel **160** to the larger diameter portion of support channel **160**. Such a connection provides a uniform transition from the smaller inner diameter of the conduit to larger inner diameter of the magneto-
25 cryogenic valve. Non-laminar flow will occur at the edges of the valve with some turbulent flow through the valve. Alternatively, an abrupt change in diameter can be constructed using a connection perpendicular to the pipes that make up the support channel **160**. This arrangement would exhibit a much different flow profile than the beveled configuration depicted in **FIG. 2**. Turbulent flow and eddy formation would be expected due to the change
30 in pipe diameters.

Non-laminar flow will occur at the edges of the valve and increased turbulent flow through the valve would be expected. Because of the larger diameter of the valve, the rate of flow of fluid will decrease, at least in some portions of the valve. The extra volume

- 40 -

produced by the larger inner diameter of the magneto-cryogenic valve initially can accommodate the magnetically susceptible particles injected into the fluid stream by the injector device, and the magnetic field generating device can be positioned so that at least a portion of its magnetic flux interacts with the magnetically-susceptible particles and attracts them or directs them within valve chamber, e.g., to the inner wall of the magneto-cryogenic valve near the heat transfer system. Individual magnetically susceptible particles each is in thermal communication with at least a portion of the conduit or valve chamber or with another magnetically susceptible particle that is in thermal communication with at least a portion of the conduit or valve chamber, increasing the heat sink area within the magneto-cryogenic valve in thermal communication with the heat transfer system. The higher thermal conductivity of the particles in thermal communication with the heat transfer system allows for increased transfer of thermal energy out of the fluid to the heat transfer system, away from the conduit.

FIG. 2 shows the magneto-cryogenic valve integrated into the conduit and attached to the conduit via connector **150**, using flanges in combination with interlocking nuts and bolts. The magneto-cryogenic valve can be connected to the conduit using any appropriate connecting means known in the art, just as a screw connection, a bolt and nut connection, rivet bolts, a bayonet fitting, interlocking tabs or any combination thereof. In some instances, flanges can be used to connect the magneto-cryogenic valve to the conduit. The flange can include any of a protruding rim, edge, rib, or collar, or combination thereof, and means for attachment for attaching the flange on one component to a flange on another component. In some instances, a flange of one component can be welded to a flange of another unit to join the pieces together, or attached to each other using a screw connection, a bolt and nut connection, rivet bolts, a bayonet fitting, interlocking tabs or any combination thereof.

An alternate configuration of the magneto-cryogenic valve is shown in **FIG. 3**. **FIG. 3** illustrates a top view of a magneto-cryogenic valve attached to a conduit, where the support channel **160** of the magneto-cryogenic valve is the same diameter as the diameter of the conduit to which it is attached. In such a configuration, fluid dynamics within the magneto-cryogenic valve is the same as within the rest of the conduit. Laminar flow is expected and the rate of flow through the system would be expected to be uniform until the magneto-cryogenic valve is activated. Once activated and the injector slurry composition containing magnetically susceptible particles is injected via the second injector device **120**,

the magnetic fields produced by the magnetic field generating devices **140** would direct the magnetically susceptible particles to a desired location or area within the conduit or valve chamber, *e.g.*, the inner walls of the conduit or valve chamber, particularly in the vicinity of the heat transfer system. Individual magnetically susceptible particles each is in thermal communication with at least a portion of the conduit or valve chamber or with another magnetically susceptible particle that is in thermal communication with at least a portion of the conduit or valve chamber, increasing the heat sink area within the magneto-cryogenic valve in thermal communication with the heat transfer system. The higher thermal conductivity of the particles in thermal communication with the heat transfer system allows for increased transfer of thermal energy out of the fluid to the heat transfer system, away from the conduit.

In some applications, the magneto-cryogenic valve is designed to be used as an emergency shut-off valve for ruptured conduits. In some instances, an existing conduit has ruptured, and the magneto-cryogenic valve is of a design that can encase the ruptured conduit. An example is depicted in **FIG. 4**. The magneto-cryogenic valve is separated into two segments that can be interconnected together on site to encircle the ruptured conduit **500**. The segments of the support channel **160a** and **160b** can be joined together using any method known in the art for joining two segments of pipe to form a continuous conduit. For example, the segments can be joined via welding, bolts, screws, seals, epoxy or any combination thereof. In some instances, a flange of one segment can be welded to a flange of another segment to join the segments together, or attached to each other using a screw connection, a bolt and nut connection, rivet bolts, a bayonet fitting, interlocking tabs or any combination thereof. The segments are aligned so that the injector devices **110** and **120** are positioned at the site of the rupture so that the injector devices are in fluid communication with the fluid within the ruptured conduit. If this is not possible, then the support channel can be installed on the ruptured conduit and appropriate equipment, such as high pressure drilling equipment appropriate for use with the pressure of the fluid within the conduit, can be used to drill openings into the ruptured conduit so that the injector devices **110** and **120** are in fluid communication with the contents of the ruptured conduit. Individual heat transfer devices can be present on each segment of the support channel of the magneto-cryogenic valve, or interconnecting segments of a single heat transfer system can be present that when connected form a contiguous heat transfer system in thermal communication with the ruptured conduit.

1. Heat Transfer System

The magneto-cryogenic valves for reversibly modulating flow of a fluid through a conduit include one or a combination of more than one heat transfer system. The heat transfer system is in thermal communication with at least a portion of the conduit from which thermal energy is to be extracted. The heat transfer system can be attached directly or indirectly to at least a portion of the conduit from which thermal energy is to be extracted, so long as it is in thermal communication with at least a portion of the conduit. The heat transfer system can be attached to the conduit in a permanent or a detachable configuration. The heat transfer system can include an annular chamber affixed around the conduit to form a cooling zone through which thermal energy is extracted from the conduit and the fluid therein.

Any refrigeration system known in the art can be used to generate negative thermal energy for the heat transfer system (*e.g.*, to cool the heat transfer system so that thermal energy flows from the fluid to the heat transfer system). Examples of refrigeration systems that can be used to reduce the temperature of, or impart negative thermal energy to, the heat transfer system include vapor compression refrigeration systems, especially with a single stage or rotary compressor, heat exchange units, cryogenic cooling and absorption systems. Heat exchange units are well known in the art (*e.g.*, see U.S. Pat. Nos. 7,441,412; 7,407,600; 7,378,065; 7,272,951; 7,263,852; 7,069,981; 7,028,768; 7,013,668; 6,185,953; 5,787,722 and 5,582,239). Electric thermal transfer devices, such as a Peltier device (*e.g.*, see U.S. Pat. No. 7,218,523) also can be used as a heat transfer system. Cryogenic cooling systems also are known in the art and can be used as a heat transfer system (*e.g.*, see U.S. Pat. No. 7,921,657; 7,415,830; 7,273,479; 7,185,501 and 6,658,864).

Any heat transfer system can be adapted for use with the magneto-cryogenic valve provided herein. For example, any of the heat transfer system described in U.S. Pat. Nos. 3,498,071; 3,623,337; 3,695,301; 3,742,723; 4,112,706; 4,220,012; 4,267,699; 4,370,862; 4,441,328; 5,836,167; 6,658,864; 7,185,501; 7,273,479; 7,415,830; or 7,921,657 or combinations thereof could be configured to be in thermal communication with at least a portion of the conduit from which thermal energy is to be extracted to serve as a heat transfer system of the magneto-cryogenic valves provided herein.

A particular heat transfer system that can serve as a heat transfer system of the magneto-cryogenic valves provided herein is described in commonly owned U.S. Pat. Appl.

13/161,411, published as U.S. Pat. Appln. Pub. No. 20110308259 (the entire disclosure of which is incorporated by reference herein).

A heat transfer system can include a detachable housing having side portions for enclosing a section of the conduit and end portions for engaging in sealing relation with
5 opposite ends of the conduit section, the side and end portions defining a cooling chamber when assembled around the conduit, the cooling chamber being operable when filled by discharging cryogen from a cryogen supply module into the chamber, which confines a volume of the cryogen at least a portion of which is in its liquid phase in intimate contact with the exterior surface of the section of conduit enclosed by the housing, the detachable
10 housing including an inlet port for admitting the cryogen from the cryogen supply module into the cooling chamber and an outlet port for discharging the spent cryogen out of the cooling chamber. The side portions of the detachable housing can include a first cylindrical half shell and a second cylindrical half shell, the first and second shells each including longitudinally extending flange portions which cooperate to permit mating engagement of
15 the shells to each other to form a closed structure, the end portions of the housing comprising radially extending flange portions for mating engagement with opposite ends of the conduit section enclosed by the housing. In this configuration, the area of the conduit encircled by the heat transfer system is the valve chamber of the magneto-cryogenic valve.

An exemplary heat transfer system integrated into a magneto-cryogenic valve is
20 depicted in **FIG. 5**. **FIG. 5** shows a cross-sectional view of a magneto-cryogenic valve. The heat transfer system **130** is attached to and in thermal conduit with the wall of the support channel **160**, which when engaged with the conduit containing fluid serves as a conduit through which the fluid flows. The support channel **160** includes connectors **150** and **150'** for connecting the magneto-cryogenic valve to the conduit in which fluid flow is to
25 be modulated. The magneto-cryogenic valve includes a first injector device **110** in fluid communication with the fluid within the conduit. The first injector device **110** as depicted is for injecting an adhesion promoter composition into the fluid prior to the fluid entering the heat transfer device. As shown, the adhesion promoter composition also would be injected into the fluid prior to the introduction of magnetically susceptible particle into the
30 fluid via the second injector device **120**. The interval between the first injector device **110** and second injector device **120** and the interval between the second injector device **120** and the heat transfer device allows the adhesion promoter composition and the magnetically susceptible particles to mix with the fluid within the conduit prior to reaching the heat

transfer device. Mixing dynamics within the fluid can be modulated by adjusting the flow rate at which either the adhesion promoter composition or the injector slurry composition or both are injected into the fluid within the conduit.

The heat transfer system **130** shown in **FIG. 5** is a cryogen cooled cavity in thermal communication with the conduit. The heat transfer system includes an inlet port **131** for introducing cryogen into the cavity of the heat transfer system. An inlet pressure regulator **132** regulates the pressure of the cryogen entering the cavity of the heat exchange device. The heat transfer system also includes an outlet port **135** for discharging warmed cryogen (gas or liquid or both). The heat transfer system includes an outlet pressure regulator for modulating the pressure of the cryogen within the cavity of the heat exchange device. By adjusting either of the pressure regulators or both regulators, the flow of cryogen through the heat transfer system can be modulated.

The pressure regulators also can be used to manipulate the temperature of the cavity within the heat transfer system. For example, the cryogen in the heat transfer system cools by an evaporative heat transfer system, in which a liquid cryogen is converted into a gas. The phase change from liquid cryogen into gas is effective for thermal energy transfer, but the resulting gas can serve as an insulating layer, thereby reducing the effectiveness of thermal energy transfer. By adjusting the pressure of the cryogen supply to the heat transfer system, the resulting gas from the warmed cryogen can be removed from the heat transfer system by the force of the incoming cryogen, removing the insulating layer of gas, thereby increasing the rate of thermal energy removal from the system.

The pressure regulator **136** at the outlet port **135** of the heat transfer system can be used to modulate the pressure of the cryogen within the cavity of the heat transfer system. To decrease the rate of cooling, the pressure control manifold can be adjusted to increase the pressure within the heat transfer system. As the pressure inside the heat transfer system increases, evaporative cooling that normally can be achieved by the conversion of liquid cryogen into a gas at atmospheric pressures is slowed or prevented, depending on the pressure within the heat transfer system. When the pressure is high, the liquid cryogen cannot be converted into a gas or converts at a slower rate than at ambient pressure, and thus thermal transfer from the fluid in the conduit to the liquid cryogen is not as high as can be achieved under lower pressure conditions. Modulating the pressure so that it is increased at a controlled rate can result in a controlled modulation of the temperature within the heat transfer system. A pressure relief valve **137** is included to relieve any excess pressure.

A heat transfer system can include segments of pipe, such as stainless steel pipe, particularly 304 stainless steel pipe, that when assembled form an outer casing and envelop at least a portion of the conduit from which thermal energy is to be extracted. The outer wall of the conduit can serve as the inner wall of the heat transfer system, defining a cooling chamber within the heat transfer system when assembled around the conduit. Alternatively, a finned pipe having a diameter slightly larger than the conduit can be fitted over the conduit prior to engagement of the segments of 304 stainless steel pipe to each other to form the enclosed cooling chamber. The finned pipe is fitted to be in thermal communication with the conduit. Steel plates having an opening through which the conduit can pass can be welded at each end of the outer casing and around conduit. With the steel plates welded in place, a sealed tube with a cavity between the conduit and the outer casing is formed, with the conduit protruding from each end.

The heat exchange system can include a conductor surface that is in thermal communication with the conduit and that includes a thermally conducting material. Any thermally conductive material known to those skilled in the art can be used as a conductor surface, when present. Examples of such materials include, but are not limited to, aluminum, beryllium, brass, cadmium, carbon steel, chrome, chrome nickel steel, cobalt, copper, gold, iridium, iron, lead, magnesium, molybdenum, nickel, platinum, silver, stainless steel, tin, zinc, and any combination or alloy thereof.

The heat transfer system can include a chamber through which a refrigerant flows. The refrigerant can include a cryogen. The cavity of the heat transfer system can contain or be filled, partially or completely, with particles, filings, turnings, shavings, pellets, threads or beads of a thermally conductive material. Including the filings, turnings, shavings, pellets, threads or beads of a thermally conductive material reduces or eliminates the Leidenfrost effect. The filings, turnings, shavings, pellets or beads of a thermally conductive material within the heat exchange unit increase surface area and can channel fluid flow or induce turbulence, which can increase the efficiency of thermal energy transfer from the conduit to the heat transfer system. Screens can be used to keep the particles, filings, turnings, shavings, pellets, threads or beads of a thermally conductive material within the cavity and to prevent their expulsion by the cryogen when the heat transfer system is charged with cryogen.

The outer casing of the heat transfer system can be fitted with cryogen compatible plumbing fittings to form one or more than one inlet port into heat transfer system for

delivery of cryogen from a cryogen supply unit into the heat transfer system. The outer casing also can be fitted with cryogen compatible plumbing fittings to form an outlet port for venting of cryogen from the heat transfer system. The outlet port can be vented to the environment or can be connected to a recapture system for recovery and reuse of the spent cryogen.

The heat exchange unit can include baffles or fins or a combination thereof that can be configured to direct or modulate the flow of cryogen or refrigerant within the heat transfer system. The baffles or fins can be perpendicular to the conduit or positioned at any angle relative to the conduit. The baffles or fins can be used to direct the flow of refrigerant or cryogen to minimize any dead zones (areas devoid of refrigerant or cryogen) within the heat transfer system. The baffles or fins can include thermally conducting material for transfer of thermal energy. The thermally conducting baffles or fins can be positioned at any location near to or in thermal contact with the conduit to increase the heat conducting area of the thermal transfer, thereby allowing the thermal energy of the conduit and its contents to more rapidly transfer to the heat exchange unit, including to the cryogen or refrigerant and/or the cooled filings, turnings, shavings, pellets or beads of a thermally conductive metal within the heat transfer system. The thermal conducting baffles and/or fins can be configured to be in thermal communication with the conduit and facilitate energy transfer from conduit to the cryogen or refrigerant and the cooled filings, turnings, shavings, pellets, threads or beads of a thermally conductive metal within the heat transfer system. The filings, turnings, shavings, pellets, threads or beads of a thermally conductive metal within the heat transfer system increase the surface area and can modulate fluid flow and/or induce turbulence, each of which can increase the efficiency of thermal transfer from the fluid within the chamber to the refrigerant or cryogen within the heat transfer system and thus out of and away from the conduit, reducing the temperature of the fluid with the conduit so that at least a portion of the fluid freezes to form a plug, which adheres to the inner wall of the conduit, preventing flow of the fluid in the conduit past the plug.

The heat transfer system also can include a heating device to melt at least a portion of the frozen plug within the conduit. The heating device can locally increase the temperature above the freezing point of the fluid, thereby melting at least a portion of the plug, thereby restoring fluid through the conduit. The heating device can locally increase the temperature using any method known in the art. For example, the heating device can introduce a fluid, such as a gas or liquid, of a temperature greater than the frozen plug, to

impart thermal energy to the frozen plug and thereby melt at least a portion of the plug. The heating device can provide heat unilaterally or directionally to the plug of frozen flow formed within the conduit. This directed application of thermal energy to the conduit in proximity to the frozen plug therein allows for directed melting of the plug, such as to form
5 a channel through the plug through which liquid fluid can flow. This can prevent launching the frozen plug through the conduit, and permits the controlled restoration of flow through the conduit.

The heating device can be selected from among any known in the art. Examples include Curie temperature heaters, conductor-in-conduit heat sources, heater strips, ceramic
10 heaters, resistance wire and resistance ribbon heating devices (*e.g.*, see U.S. Pat. Nos. 3,793,716; 3,814,574; 4,238,640; 7,066,730; 7,461,691; and U.S. Pat. Pub. Nos. 2004-0020642 and 2005-0092483). Commercial embodiments of resistance wire or resistance ribbon heating devices are available (Calrod™ heaters), which could be configured to conform to the size and shape of the heating channel. The heating unit can be contained
15 within a channel and can be configured so that it is in thermal communication with the conduit but thermally isolated from the heat transfer system. For example, the portion of the heating channel directed toward the heat exchange unit can be separated therefrom by using a thermally non-conducting material. Any thermally non-conducting material known to those of skill in the art can be used.

Alternative heat transfer systems can be used. **FIG. 10** shows a magneto-cryogenic
20 valve **100** that includes, as a heat transfer system, cryogenic cooling coils **155**. The cryogenic cooling coils **155** include an inlet port **131**, that can be connected to an inlet pressure regulator **132**, which is connected to a cryogen supply module via pipe **133**. The cryogenic cooling coils **155** also include an outlet port **135** connected to an outlet pressure
25 regulator **136**, and a pressure relief valve **137** and a vent **138**. A plurality of separate cryogenic cooling coils can be used, or a continuous tubing forming the cryogenic cooling coils can be used. The cryogenic cooling coils can be placed in or around the magneto-cryogenic valve, or the chamber of the magneto-cryogenic valve, in any configuration, such as a spiral wrap or parallel wrap.

Heat transfer systems also can include cooling chambers adjacent to the valve
30 chamber of the magneto-cryogenic valve. The cooling chambers allow transfer of thermal energy from the valve chamber to the cryogen in the cooling chambers and ultimately out of the magneto-cryogenic valve. The cooling chambers can be integrated into the valve

chamber segments of the valve. For example, see **FIG. 15**. This cross section of a magneto-cryogenic valve **100** shows the first cooling chamber segments **700** adjacent to the first valve chamber segment **620**, and the second cooling chamber segments **701** adjacent to the second valve chamber segment **621**. Joining the first and second segments results in a plurality of cooling chambers in proximity to the valve chamber. Cryogen enters each cooling chamber via a port **705** and exits via a port **706**, (although this could be reversed so that the cryogen enters each cryogen circulation compartment via a port **706** and exits via a port **705**).

The cooling chamber can have smooth walls, or the walls of the cooling chamber can be ridged, fluted, grooved, furrowed, crinkled, puckered, creased or wrinkled, such as to increase the surface area of the cooling chamber, such as shown in **FIG. 27**. The cooling chamber can contain or be filled with particles, filings, turnings, shavings, pellets, threads or beads of a thermally conductive material. The cooling chamber can contain baffles or fins.

Activation of the heat transfer system can include providing a refrigerant or a cryogen to the device, or providing power to or otherwise turning on a Peltier device or other electrical cooling device. The temperature of the heat transfer system and the temperature along and/or within the conduit can be monitored with thermal monitoring devices or other temperature sensors such as thermocouples. The thermal monitoring devices can be coupled to and provide input(s) to a computer module. For example, the heat transfer system can include thermal monitoring devices that can be attached to one or more points of the conduit or valve chamber to monitor a thermal gradient and can be included at the interface between the heat transfer system and the conduit to monitor the temperature at the interface. A computer that controls or is in communication with the heat transfer system and the thermal monitoring devices can monitor the thermal gradient and/or rate of thermal exchange and control either or both in order to minimize or eliminate thermal stress on the conduit. Remote control of the heat transfer system could include, *e.g.*, start up and shut down of the refrigeration unit, and valve actuation to regulate or modulate the flow of refrigerant or cryogen to the heat transfer system. The heat transfer system also can include pressure monitoring devices, which can be monitored or accessed remotely via a computer, to assess the pressure, *e.g.* of a vapor, in the heat transfer system. The heat transfer system also can include pressure relief valves, which can be monitored or accessed remotely via a computer, to modulate the pressure, *e.g.* of a vapor, in the heat transfer system.

The source of negative thermal energy, or cooling power, such as a refrigeration unit or refrigerant or cryogen supply module, for the heat transfer system of the magneto-cryogenic valve can be positioned so that it is in any location with reference to the magneto-cryogenic valve. In some instances, the source of negative thermal energy is positioned in a vicinity close to the conduit from which thermal energy is to be extracted. By positioning, *e.g.*, a refrigeration unit or refrigerant or cryogen supply module in close proximity to the conduit, the length of hoses or pipes from the source of negative thermal energy to the heat transfer system of the magneto-cryogenic valve can be minimized. For sub-surface ocean environments, a submersible housing can be used to enclose the source of negative thermal energy to protect it from its submerged environment.

In some instances, the source of negative thermal energy, or cooling power, can be located a remote distance from the conduit to which the magneto-cryogenic valve is to be attached. For example, the conduit from which thermal energy is to be extracted can be located on the seabed, and the source of negative thermal energy can be located on a ship or platform on the surface, connected to the cooling unit via hoses or pipes, which can be difficult to maintain during periods of rough seas. Instead, the source of negative thermal energy, or cooling power, such as a refrigeration unit or refrigerant supply module, can be positioned so that it is in close vicinity to the conduit from which thermal energy is to be extracted.

2. Injector device

The magneto-cryogenic valve provided herein includes at least one injector device for introducing a material into the fluid within the conduit. One of the materials injected into the fluid is a slurry containing magnetically susceptible particles. In addition, an adhesion promoting composition also can be injected into the fluid within the conduit. In some applications, the magneto-cryogenic valve includes at least one injector device for introducing an injection slurry containing material that interacts with a magnetic field into the fluid within the conduit. In some applications, the magneto-cryogenic valve includes one or more injector devices for introducing an injection slurry containing material that interacts with a magnetic field into the fluid within the conduit and one or more than one injector devices for introducing an adhesion promoting composition into the fluid within the conduit.

The injector device can be configured to include a port or opening in the conduit through which a material can be introduced into the conduit so that the material comes into

contact with the fluid within the conduit. The injector device can include an isolation mechanism for controlling the introduction of the material into the fluid in the conduit. Any isolation mechanism known in the art can be used. For example, a mechanical valve that can be opened and closed can be used as an isolation mechanism, preventing fluid from the conduit to flow into the injector device and material from the injector device to flow into the conduit. The mechanical valve can be controlled manually or remotely, such as by including a computer operated or electrically activatable valve. When activated, the mechanical valve opens to introduce the material into the fluid within the conduit. When deactivated, the mechanical valve closes to stop flow of material into the conduit.

10 In some embodiments, a check valve can be included in the injector device. The check valve can be used as an isolation mechanism and/or can be used to prevent the back flow of fluid in the conduit, such as oil in the flow tubular, into the injector device. Any check valve that is operative at reduced temperatures, particularly cryogenic temperatures, can be used. Not all applications require a check valve; according, a check valve may not be present in the injector device for some applications. For example, in applications where the injection slurry is delivered at a greater pressure than the expected internal pressure of the conduit or tubular, once the flow of injection slurry is stopped, a check valve would not be required. The injector device can be isolated from the conduit by a manually or remotely operated valve suitable to contain the type and pressure of fluid in the conduit.

20 The injector device can include one or more activatable flow modulating valves that can adjust the flow of material to and/or through the injector. The activatable flow modulating valves can be activated manually or remotely, *e.g.*, by use of a computer. For example, the injector device can include remotely activatable solenoid flow modulating valves between the source of the material to be injected into the fluid and the injector valve. For example, a flow modulating valve can be used to regulate the flow of the injection slurry from a supply module to and through the injector device(s).

25 Passages in a well casing can be provided for the injector device to be positioned to direct the introduction of material into the fluid in a conduit, *e.g.*, a producing tubular, when the injector device is activated. Tubes, pipes or conduits to the injector device that can be used to deliver material to be injected into the fluid can be fabricated into each layer of casing and the casings then can be aligned to produce the passageways to deliver the material to the injector device(s). The tubing or pipes to convey the material to be injected also can be incorporated into an annular space formed between two concentric pipes.

The injector device and its components can be made of any material appropriate for the conditions under which they are to be used. For example, the tubing or piping used for construction can be engineered to resist not only the expected pressures of the fluid within the conduit, but also the high water pressures that exist at depths of deep sea drilling, including depths of about 7,000 feet under water. Those skilled in the art can select the proper material and thickness or design of the piping or tubing for such applications. The piping or tubing can include radial or lateral reinforcements to withstand collapse under the pressure of the water pressures that exist at deep sea drilling depths. The piping or tubing can be manufactured to be of a thickness such that the piping or tubing is resistant to deformation or crushing by the water pressure at sea depths of deep sea drilling. Exemplary materials include stainless steel, aluminum, copper, or cryogenically compatible polymers, such as fiber-reinforced epoxy composites and ultra-high molecular weight polyethylene. The injectors, tubing or pipes also can be of an alloy having a ductile fracture mode higher than steel and a brittle fracture mode lower than steel. Exemplary alloys include those described in U.S. Pat. Nos. 5,352,304; 6,183,573; 6,212,891; 7,235,212; 7,648,597 and 7,727,463.

The tubing or piping of the injector device can be insulated to minimize thermal contamination from the surrounding environment. Any technique known to those of skill in the art for insulating piping can be used. The tubing or piping can be encircled or enveloped in a non-thermally conductive material or a material having a low thermal conductivity.

The injector device of the magneto-cryogenic valve can include a flow rate meter. The flow rate meters can be in communication with a computer module. Data from the flow rate meters can be used to determine the flow of material through the injector device(s), and can be used to modulate the rate of flow of material into the fluid within the conduit, either manually or automatically by computer control. Flow rate meters can be included throughout the path of fluid communication from the material supply module to the exit point of the material from the injector device into the fluid for determination of rate of flow of material through the system. Any flow meter known in the art can be used in the system. The flow meter can include a paddle wheel flow meter, a turbine flow meter, a magnetic flow meter, optical sensors, electromagnetic velocity sensors, coriolis force flow meters, thermal flow meters, ultrasonic flow meters or any other type of flow meter known in the art. Examples of flow meters known in the art include U.S. Pat. Nos. 7,730,777; 7,707,898;

4,934,196; 4,422,338 and RE 31,450, and U.S. Pat. Appl. Pubs. 2009-0281671, 2005-0288873 and 2004-0244498.

The injector device can include other components, such as an emergency shut-off valve, an over-pressure valve, a diverter valve, heating units, and thermal monitoring devices.

5 A computer module can be used for automation of the injector device or any of its attached components. For example, the computer module can be in communication with and/or in control of heating units, valves, flow rate meters and thermal monitoring devices and can monitor and/or control the flow of material, *e.g.*, the injection slurry, through the injector device into the fluid within the conduit.

10 **3. Magnetic Field Generating Device**

The magneto-cryogenic valve provided herein includes a magnetic field generating device. The magnetic field generating device can include one or more magnets. The magnets can be electromagnets or permanent magnets or a combination thereof. In some applications, electromagnets are preferred. The magnetic field generating device can be
15 positioned and oriented in any direction, *e.g.*, the magnetic field generated by the device can be directed parallel or perpendicular to the conduit. **FIG. 11** and **FIG. 13** show an exemplary magneto-cryogenic valve that includes electromagnets as the magnetic field generating devices **140**. The electromagnets include an electromagnetic core **650** and an electromagnetic solenoid coil **640**. The cores **650** can be attached via an electromagnetic core end **655** using an electromagnetic core flange **656**. **FIGS. 19A** and **19B** show ports **680** where a magnetic field generating device, such as a permanent magnet or an electromagnet, can be inserted. The poles of the magnetic field generating device can be flush with the wall of the valve chamber or can penetrate into the valve chamber.

In some applications, the magnetic field generating device employs electromagnets.
25 The electromagnets can include windings of an electrical wire (typically made of aluminum, copper or alloys thereof) around a core, which typically, but not necessarily, includes a ferrous material. Passing an electrical current from a power supply through the electrical wire creates a magnetic field. The strength of the magnetic field can vary with the amount of current passed through the electrical wire, the number of windings that the electrical wire is
30 wrapped around the core, the type(s) of material(s) that makes up the core, and the size and shape of the core. There is a direct correlation between the number of times electrical wire is wound around a core and the strength of the magnetic field that is generated from an electromagnet. The flux density that is generated is directly related to the number of

windings of the electrical wire in that the greater number of windings, the stronger the magnetic field.

A plurality of electromagnets can be used to generate the magnetic field within the chamber. Any configuration of electromagnets can be used. For example, two

5 electromagnets can be positioned 180° from each other in a circular orientation around the chamber of the magneto-cryogenic valve. Three electromagnets can be positioned 120° from each other in a circular orientation around the chamber of the magneto-cryogenic valve (e.g., see **FIG. 12**). Four electromagnets can be positioned 90° from each other in a circular orientation around the chamber of the magneto-cryogenic valve (e.g., see **FIG. 1**). The
10 electromagnets can be modular and attached or removed from the magneto-cryogenic valve, such as by use of flanges (e.g., see **FIG. 12**, electromagnetic core flange **656**).

Although the solenoid coils **640** of the electromagnets shown in **FIG. 12** encompass essentially the whole length of the valve chamber, in some applications the solenoid coils can extend the entire length of the core **650**. The electromagnetic core **650** can be the entire
15 length of the magneto-cryogenic valve **100**. Although the electromagnets shown in **FIG. 12** are shown encompassing essentially the whole length of the valve chamber, one set of electromagnets can be used for the first segment of the valve chamber and a separate set of electromagnets can be used for the second segment of the valve chamber. Also, although the electromagnets shown in **FIG. 12** are oriented in line with the flow of fluid through the
20 magneto-cryogenic valve, the configuration of the electromagnets can be changed so that their orientation is perpendicular to the direction of flow, and separate sets of electromagnets can be used for the first and second segments of the valve chamber.

In some configurations, when electromagnets are used as the magnetic field generating devices, the electromagnetic cores do not penetrate into the valve chamber. An
25 exemplary configuration is shown in **FIG. 14**. In the figure, two of the electromagnets containing electromagnetic solenoid coils **640** and electromagnetic cores **650** are shown. The magnetic field generator ends **685** do not penetrate the valve chamber.

In some configurations, when electromagnets are used as the magnetic field generating devices, the electromagnetic cores do penetrate into the valve chamber. An
30 exemplary configuration is shown in **FIG. 24**. In the figure, two of the electromagnets containing electromagnetic solenoid coils **640** and electromagnetic cores **650** are shown. The electromagnetic core ends **655** penetrate the valve chamber and are within the valve chamber.

The electromagnets in any configuration can be activated and deactivated in any order and at any time in order to modulate particle collection or plug integrity or both. The electromagnets can be activated sequentially around the perimeter of the chamber, or can be activated in groups, such as in pairs or triples. The electromagnets can be activated and
5 deactivated in a manner that results in an oscillating magnetic field within the chamber. An oscillating magnetic field can be used to optimize granular bed formation or to induce heating in the plug to melt the plug or to partially or completely dislodge the plug from the inner wall of the chamber. The electromagnets can be deactivated to induce or accelerate plug failure, such as when flow through the pipeline is to be restored.

10 The cores of the electromagnets can be connected to the magneto-cryogenic valve using any appropriate attachment techniques, such as using screws or nuts and bolts in combination with flanges or by welding. The core ends can be flush against the walls of the valve chamber or can penetrate into the valve chamber. When the core ends are configured to enter the valve chamber, the configuration is selected so that the core ends do not inhibit
15 or in any way interfere with the ability of any movable inline inspection or cleaning devices to traverse the valve chamber. The bodies of the magnets or the cores of the electromagnets can directly touch the external wall of the magneto-cryogenic valve, or the device can be configured so that the magnets or electromagnets are connected so that they do not touch the external wall of the magneto-cryogenic valve.

20 When electromagnets are used to produce the magnetic field, the magnetic field can be modulated by controlling the amount of current flowing through the electrical wire. Moreover, the magnetic field can be eliminated by turning off the current. This avoids any damage that could be caused by a constant magnetic field applied to a conduit, such as any abrasive deterioration that could be caused to the inner wall of the conduit by attraction of
25 magnetic materials in the fluid during normal operation of the conduit. Conversely, during an emergency or in expectation of a potential emergency, the magnetic field generating device of the magneto-cryovalve quickly can be activated by providing current to the electrical wire windings around the core to generate a powerful magnetic field.

In some applications, the magnetic field generating device employs permanent
30 magnets. Permanent magnets are objects made from material that is magnetized to create a persistent magnetic field that cannot be turned off like the magnetic field of an electromagnet. The permanent magnets can be ceramic, ferrite, or include any other appropriate magnetic material. In some instances, the permanent magnets include rare earth

elements. For example, the permanent magnets can be rare earth permanent magnets selected from among Nd-Fe-B type, Sm-Co type and Sm-N-Fe type rare earth permanent magnets. The permanent magnets can be mounted on movable tracks so that the proximity of the magnets to the conduit can be modulated. For example, the magnets can be

5 positioned closer to the conduit or moved away from the conduit in order to adjust the strength of the magnetic field experienced by magnetically susceptible particles within the conduit or valve chamber. In some applications, the magnetic field generating device includes permanent magnet assemblies combined with electromagnets. The permanent magnets or electromagnets can be configured in pairs, or in cross-shaped configurations, or

10 in a multi-pole configuration to generate magnetic fields of different shapes or magnetic fields oriented in a particular direction. **FIG. 6A** is illustrative of a magneto-cryogenic valve that includes two electromagnets positioned axially about the chamber of the magneto-cryogenic valve. **FIG. 6B** is illustrative of a magneto-cryogenic valve that includes four magnetic field generating devices, such as permanent magnets, positioned at

15 the corners of the valve chamber of the magneto-cryogenic valve. **FIG. 12** is illustrative of a magneto-cryogenic valve that includes three electromagnets positioned axially about the chamber of the magneto-cryogenic valve. **FIG. 26** is illustrative of a magneto-cryogenic valve that includes twenty separate electromagnets (12 shown in the figure) positioned axially about the end walls and the side walls of the valve chamber of the magneto-

20 cryogenic valve.

Individual magnetic field generating devices, whether electromagnets or permanent magnets, can be used alone or in combination at many different locations with respect to the valve chamber. The number and location of the magnetic field generating devices can be selected to optimize plug formation. Exemplary placement locations for the magnetic field

25 generating devices include inside the valve chamber, outside the valve chamber and embedded in the valve chamber wall, and any combination of these locations. The polarization and strength of each magnetic field generating device can be varied individually. Each of the magnetic field generating devices can be individually oscillated.

Any type of magnetic field generating devices can be used. In some applications, a

30 permanent magnet, an electromagnet or a combination thereof is used. Types of magnets that can be used include alnico, ceramic, alnico, and rare earth magnets, such as neodymium iron boron magnets. Magnets of the same or differing magnetic flux densities can be selected. In some applications, the magnetic field generating device is selected to produce a

magnetic flux density of at least 0.25 Tesla. In some applications, a magnetic field generating device has a magnetic flux density of at least 0.5 Tesla, or at least 1 Tesla, or at least 1.5 Tesla, or at least 2 Tesla, or at least 2.5 Tesla, or at least 3 Tesla, or at least 3.5 Tesla, or at least 4 Tesla, or at least 4.5 Tesla, or at least 5 Tesla, or at least 5.5 Tesla, or at least 6 Tesla, or at least 6.5 Tesla, or at least 7 Tesla, or at least 7.5 Tesla, or at least 8 Tesla, or at least 8.5 Tesla, or at least 9 Tesla, or at least 9.5 Tesla, or at least 10 Tesla. In some applications, a magnetic field generating device has a magnetic flux density of about 0.1 Tesla to about 15 Tesla. In devices using a plurality of magnetic field generating devices, at least two of the magnetic field generating devices are positioned in a manner to cause the field lines of at least one magnet to penetrate through to the fluid flowing through the chamber of the magneto-cryogenic valve and make contact or interact with the like field of another magnetic field generating device. In some applications, the magnetic field generating devices are configured to provide a flux density of from about 0.5 Tesla to about 5 Tesla within the valve chamber, such as at the center of the valve chamber, or at any other desired location within the valve chamber. The strength, size, shape and position of the magnetic field generating device(s) can be selected so that the magnetic field generated produces field lines at least a portion of which penetrate through to the fluid flowing through the valve chamber and interact with the magnetically susceptible particles injected into the fluid flowing through the valve. The magnetic fields can be used to direct the deposition of the magnetically susceptible particles. In some applications, the magnetic field concentrates the magnetically susceptible particles near or at the center of the valve chamber. In some applications, the magnetic field concentrates the magnetically susceptible particles near or at an end of the valve chamber. In some applications, the magnetic field concentrates the magnetically susceptible particles near or at a wall of the valve chamber. In some applications, the magnetic fields of a plurality of magnets can be used to concentrate the magnetically susceptible particles near or at more than one location within the valve chamber. In some applications, the magnetic fields can be used to concentrate the magnetically susceptible particles near the center of the valve chamber and near a wall of the valve chamber.

In some applications, the magnetic field generating device of the magneto-cryovalve includes a plurality of electromagnets in which oscillation of the B-field can be induced. By inducing an alternating magnetic field, inductive heating can be produced. For example, some of the magnetically susceptible particles in the slurry can include a ferromagnetic

coating. An alternating magnetic field can excite domains in the ferromagnetic coating. As the domains of the coatings realign with each oscillation, hysteresis losses in the coating can cause inductive heating. The inductive heating can be proportional to flux density within the magnetically permeable coating. This increased thermal energy produced by inductive heating can be used to melt the plug of frozen fluid in the conduit, restoring fluid flow. Thus, an alternating magnetic field to produce inductive heating can obviate the need for providing separate thermal energy devices, such as heating devices, to restore flow of the fluid in the conduit. In some instances, heaters are included in the magneto-cryogenic valve and can be used alone or in conjunction with the magnetically produced inductive heating to provide thermal energy to melt the plug within the conduit or valve chamber.

The magnetic field generating device can be positioned so that its magnets are in any configuration about the conduit. In some applications, the magnets can be positioned circumferentially about the conduit. In some applications, the magnets can be positioned uniaxially or biaxially parallel to the flow direction. In some applications, one magnet can be positioned opposite of another magnet. Each of the magnets generates a magnetic field at least a portion of which permeates the wall of the conduit and interacts with the magnetically susceptible particles introduced into the fluid of the conduit. The positioning of the poles of the magnets of the magnetic field generating device also can be modulated to direct the magnetically susceptible particles within the fluid in the conduit or valve chamber. For example, a standard quadrupole magnet configuration can be used to create a magnetic field whose magnitude grows rapidly with the radial distance from its longitudinal axis. In a standard quadrupole configuration, with four magnets in a cross-shaped configuration, two are positioned to have opposing north poles and two are positioned to have opposing south poles. In such a configuration, the magnetic field in the center is very low and can be zero, and the magnetic field increases as one moves away from the center. This could be used to attract the magnetically susceptible particles in the fluid toward the walls of the conduit, as the magnetic field would be much greater toward the inner surface of the conduit than in the center of the conduit.

This is illustrated in **FIGS. 6A** and **6B**. **FIGS. 6A** and **6B** show the accumulation of magnetically susceptible particles at the inner wall of the conduit in the vicinity of the heat transfer system. Magnetically susceptible particles **170** are injected into the fluid within the conduit via injector device **120**. The Magnetically susceptible particles can contain any material that interacts with a magnetic field. The material can be attracted to or repulsed by the

magnetic field. The particles can contain cobalt, Co-Zr alloys, Co-Nb alloys, dysprosium, Fe-Si alloys, gadolinium, iron, mu metal (nickel iron alloy), nickel, permalloys (iron-nickel alloys), rare earth-transition metal alloys (*e.g.*, Gd-Co, Fe-Tb), spinel ferrites (MFe_2O_4 where M is Mn^{2+} , Fe^{2+} , Co^{2+} , Ni^{2+} , Cu^{2+} and Zn^{2+}) and supermalloy. In particular, the magnetically susceptible particles can contain cobalt, iron, nickel, magnetite (Fe_3O_4) or maghemite (Fe_2O_3) or combinations thereof.

Once injected into the fluid within the conduit, the magnetically susceptible particles **170** interact with the magnetic fields produced by the magnetic field generating devices **140**. The interaction results in the magnetically susceptible particles **170** moving toward and accumulating on the walls of the conduit, in the center of the valve chamber, at an end of the valve chamber, or any combination thereof. Some of the particles are in direct thermal communication with the conduit wall that is in thermal communication with the heat transfer system **130**. Other magnetically susceptible particles are in thermal communication with the particles thermal communication with the conduit wall that is in thermal communication with the heat transfer system **130**. Because the thermal conductivity of the magnetically susceptible particles **170** is greater than the thermal conductivity of the fluid within the conduit, thermal energy is transferred from the fluid to the magnetically susceptible particles **170** and subsequently to the conduit in thermal communication with the heat transfer system **130** and away from the conduit, thereby removing thermal energy from the fluid and ultimately resulting in formation of a frozen plug of fluid.

The magneto-cryogenic valves, systems and methods provided herein can be used in any environment, including with surface pipelines and sub-sea and deep sea applications. The magneto-cryogenic valves can be operated manually or can be configured to be remotely controlled, such as by a computer programmed with appropriate software. When the method is used underwater, such as on the ocean floor, a fully submersible refrigeration unit or cryogen supply module can be used. Control of the submerged refrigerator system or cryogen supply module can be provided from the surface, *e.g.* from a vessel or platform, such as by attached wires or cables that can provide power, communication and monitoring between the heat transfer system of the magneto-cryogenic valve and the surface. The refrigeration unit or cryogen supply module can be enclosed in a pressure vessel or housing to minimize exposure to water and to allow regulation of the pressure within the vessel or

housing. The refrigeration unit and its compressor drive motor can be powered by a supply from a surface vessel or platform or via batteries or a submerged generating system.

C. SYSTEMS

The magneto-cryogenic valve provided herein can be part of a system that extracts
5 thermal energy from a conduit in order to freeze at least a portion of the fluid contents
therein. An exemplary system includes the magneto-cryogenic valve attached to at least a
portion of the conduit and in thermal communication therewith, a slurry module for
providing injection unit for injecting a slurry containing magnetically susceptible particles
into the fluid within the conduit, optionally an injector for injecting an adhesion promoting
10 composition into the fluid within the conduit, and optionally a control system for computer
and/or remote control of the magneto-cryogenic valve and the injector(s). The system can
include, and in exemplary embodiments does include, other components, such as valves,
e.g., flow control valves, diverter valves and pressure relief valves, pumps, tubing or piping,
one or more injection slurry supply modules, adhesion promoter composition supply
15 modules, cryogen supply modules, pressure and/or temperature monitoring devices, flow
measuring devices and a computer control module.

An exemplary system is shown in **FIG. 7**. **FIG. 7** illustrates a horizontally oriented
conduit system, although vertically oriented conduit systems also are envisioned. The
system includes a magneto-cryogenic valve that includes a first injector device **110** and a
20 second injector device **120** attached to a support channel **160**, a heat transfer system **130**
surrounding at least a portion of the support channel **160**, and magnetic field generating
devices **140** shown in a quadropole arrangement (the fourth magnetic field generating
device **140** is not visible in the illustration). The positioning of the magnetic field
generating devices **140** can be modified to generate different magnetic fields due to the
25 interaction of the magnetic field generating devices **140**. The support channel **160** of the
magneto-cryogenic valve can be connected at one end to a conduit **500** containing a fluid
via connector **150** and at the other end to conduit **500'** via connector **150'**. As illustrated,
the fluid fluids through the conduit from conduit **500** to conduit **500'**.

The first injector device **110** is connected via piping **111** to a pump **112** that is
30 connected via piping **113** to an adhesion promoter composition supply module **200**. The
second injector device **120** is connected via piping **121** to an injection slurry supply module
300 that is connected via piping **125** to a pressure regulating system **350**.

The heat transfer system **130** is attached to and in thermal communication with support channel **160**. The heat transfer system **130** includes an inlet port **131** that can include an inlet pressure regulator **132**. The inlet port **131** can be attached directly to a pipe **133** or to the inlet pressure regulator **132** connected to the pipe **133** to a cryogen supply
5 module **400**. The heat transfer system **130** also includes an outlet port **135** that can include an outlet pressure regulator **136**. The outlet port **135** includes a pressure relief valve **137** and a vent **138**, connected directly to the outlet port **135** or to the outlet pressure regulator **136** that is connected to the outlet port **135**.

The system can include thermal monitoring devices that can be attached to one or
10 more points of the conduit to monitor a thermal gradient and can be included at the interface between the heat transfer system and the conduit to monitor the temperature at the interface. The system can include a computer that controls or is in communication with the magneto-cryogenic valve and the thermal monitoring devices.

1. Injection Slurry Supply Module

15 Systems including the magneto-cryogenic valve provided herein can include an injection slurry supply module. The injection slurry supply module provides the injection slurry to the injector. The injection slurry contains magnetically susceptible particles in a fluid, such as a cryogen or a solvent or a combination thereof. The slurry can be prepared using any method known in the art. For example, an injection slurry supply module can
20 include a mixing system that includes a venturi pump, such as a fluid jet eductor. In such systems, flowing fluids can be passed through piping configurations that cause a pressure differential sufficient to draw in particles, such as the magnetically susceptible particles, to be mixed with the flowing fluid, such as a cryogen or a solvent or a combination thereof. Jet eductor systems are well known in the art (*e.g.*, see U.S. Pat. Nos. 4,165,571; 5,522,419;
25 5,743,637; 5,993,167; and 6,450,775) and can be used with the injection slurry described herein. An exemplary eductor can be configured to include a nozzle, which can direct a fluid, such as cryogen, to form a jet; a venturi structure, and an air gap between the nozzle and the venturi structure. In use the fluid jet passes across the air gap and enters the venturi structure. The venturi structure includes an inlet, a side passage for delivering the
30 magnetically susceptible particles into the fluid jet and a mixing chamber where the magnetically susceptible particles are entrained and mixed with the fluid by the flow of the fluid.

The magnetically susceptible particles alone or in combination with other particles, can be supplied to the venturi structure via a tube, pipe or chute having a discharge end located near the inlet of the venturi structure, where a vacuum (negative pressure) created by the high velocity fluid flow therein acts to draw the particles from the tube, pipe or chute into the venturi structure. One method of controlling the amount of magnetically susceptible particles or other particles added to fluid within the conduit is to include a metering device, such as auger barrel, to regulate the amount of magnetically susceptible particles or other particles flowing through the auger and into the venturi mixing chamber by means of a variable speed motor driving the auger. Any metering device or flow regulation devices known in the art can be used to meter the amount of particles that are added to the flowing fluid and thereby to regulate the amount of particles, *e.g.*, magnetically susceptible particles, added to the cryogen or other fluid flowing through the eductor.

The flow of the injection slurry composition into the injector can be modulated by any method known in the art. For example, a pressure regulator system can be attached to the injection slurry module to force the slurry from the supply module into and out of the injector into the fluid within the conduit. Increasing or decreasing the pressure exerted on the injector slurry in the supply module by using the pressure regulating system can result in increased or decreased flow, respectively, out of the injector into the fluid.

a. Injection Slurry Composition

i. Magnetically Susceptible Particles

The injection slurry composition contains magnetically susceptible particles. The magnetically susceptible particles can be of or contain a material that interacts with a magnetic field. The particles can be paramagnetic, diamagnetic, ferromagnetic or any combination thereof. Examples of paramagnetic materials include aluminum and titanium. Examples of diamagnetic materials include bismuth, copper and gold. Examples of ferromagnetic materials include cobalt, Co-Zr alloys, Co-Nb alloys, dysprosium, Fe-Si alloys, gadolinium, iron, mu metal (nickel iron alloy), nickel, permalloys (iron-nickel alloys), rare earth-transition metal alloys (*e.g.*, Gd-Co, Fe-Tb), spinel ferrites (MFe_2O_4 where M is Mn^{2+} , Fe^{2+} , Co^{2+} , Ni^{2+} , Cu^{2+} and Zn^{2+}) and supermalloy. The magnetically susceptible particles can contain cobalt, iron, nickel, magnetite (Fe_3O_4) or maghemite (Fe_2O_3) or combinations thereof.

The magnetically susceptible particles generally can be selected so that they have a thermal conductivity value much greater than the thermal conductivity of the fluid within

the conduit. For example, the thermal conductivity of crude oil is in the range of from 0.120 to 0.130 W/(m·K). The thermal conductivity of exemplary materials, at 68°F, include 31 W/(m·K) for carbon steel, 40 W/(m·K) for cobalt, 223 W/(m·K) for copper, 42 W/(m·K) for pure iron, 52 W/(m·K) for nickel, 30 W/(m·K) for niobium, 235 W/(m·K) for silver, and 116 W/(m·K) for zinc. Thus, the magnetically susceptible particles can be selected to have a thermal conductivity greater than 0.2 W/(m·K), or greater than 0.5 W/(m·K), or greater than 0.75 W/(m·K), or greater than 1 W/(m·K), or greater than 5 W/(m·K), or greater than 10 W/(m·K), or greater than 20 W/(m·K), or greater than 30 W/(m·K), or greater than 40 W/(m·K), or greater than 50 W/(m·K) or greater than 100 W/(m·K).

Commonly owned U.S. Pat. Appl. 13/161,411, published as U.S. Pat. Appln. Pub. No. 20110308259 (the entire disclosure of which is incorporated by reference herein) describes methods, devices and systems for extraction of thermal energy from a heat conducting metal conduit. In some embodiments described in U.S. Pat. Appl. 13/161,411, a cryogen is injected into a fluid within a conduit to increase the rate of thermal energy dissipation from the fluid within the conduit. The injection slurry composition that is injected into the fluid within the conduit using the magneto-cryogenic valve includes magnetically susceptible particles in a fluid. The fluid can be a refrigerant or cryogen or a combination thereof.

Introducing the injection slurry into the fluid within the conduit can increase the rate of thermal energy transfer from the fluid within the conduit than that observed with injection of cryogen or refrigerant alone. An advantage over previous devices and methods is that, by modulating the magnetic flux of the magnetic field generating device, the magnetically susceptible particles of the slurry can be attracted to or directed to the inner surface of the conduit so that they are in thermal communication with at least a portion of the conduit, particularly in the vicinity of the heat transfer system to remove thermal energy from the conduit. For example, the magnetic field generating device can be positioned so that its magnetic fields direct the magnetically susceptible particles of the injection slurry composition to the inner wall of the conduit close to the heat transfer system that is in thermal communication with at least a portion of the conduit, and the magnetically susceptible particles facilitate thermal energy transfer from the fluid within the conduit to the heat transfer system for removal.

Deposition of the magnetically susceptible particles of the slurry on the inner wall of the conduit effectively increases thermal conductance at the inner wall of the conduit when

the magnetic field generating device is activated and the injection slurry is introduced into the fluid within the conduit. The thermal conductance of the conduit is increased because the deposited magnetically susceptible particles of the slurry are in thermal communication with at least a portion of the conduit or valve chamber, or with one or more magnetically susceptible particles in thermal communication with the conduit or valve chamber, or form a chain of magnetically susceptible particles at least one of which is in thermal communication with the conduit or valve chamber. Because the thermal conductivity of the magnetically susceptible particles is greater than the thermal conductivity of the fluid within the conduit or valve chamber, thermal energy is transferred to the particles and subsequently to the conduit or valve chamber in thermal communication with the heat transfer system and away from the conduit, thereby removing thermal energy from the fluid and ultimately resulting in formation of a frozen plug of fluid .

The insulating effect of frozen fluid, having a low thermal conductance, is overcome by the introduction of magnetically susceptible particles having a higher thermal conductance than the frozen fluid, providing a thermal communication pathway through the frozen fluid to the heat transfer device. This results in rapid concentric freezing of the fluid within the conduit or valve chamber in a much shorter amount of time than could be accomplished by use of only a heat transfer device attached to the conduit or valve chamber.

The magnetically susceptible particles, which can be cooled to a temperature below the freezing point of the fluid within the conduit, accelerate the removal of thermal energy from the fluid and its solidification and freezing and/or formation of a frozen plug. The magnetically susceptible particles can serve as nucleation sites upon which or due to which the fluid within the conduit in contact with the particle loses thermal energy and can solidify. The increase in the number of nucleation sites in the fluid as the thermal energy of the fluid is decreased can accelerate the formation of multiple portions of at least partially solidified solid fluid within the conduit or valve chamber. The multiple portions of at least partially solidified solid fluid can interact with the magnetic field of the magnetic field generating device and be directed to any desired location within the conduit or valve chamber, such as to the center of the valve chamber, to one end of the valve chamber, or to a wall of the valve chamber in the vicinity of the heat transfer system, where they adhere due to a combination of the magnetic field as well as freezing to the pre-cooled conduit by action of the heat transfer system. The multiple portions of at least partially solidified fluid within the conduit also can collide with each other to form larger aggregates, which can be

directed to the wall of the conduit in the vicinity of the heat transfer system by interacting with the magnetic field of the magnetic field generating device. The proliferation of collisions of aggregates and their directed deposition by virtue of the interaction with the magnetic field of the magnetic field generating device can be sufficient to cause formation
5 of a frozen plug in the conduit in significantly less time than when a cryogen alone is injected into the fluid in a conduit.

The combination of the heat transfer system removing thermal energy from the conduit or valve chamber and its contents from the outside-in, and the introduction of negative thermal energy into the fluid within the conduit or valve chamber by injecting the
10 injection slurry containing magnetically susceptible particles having a thermal conductivity value much greater than the thermal conductivity of the fluid results in the rapid removal of thermal energy from the fluid and formation and building of frozen fluid on the walls of the conduit or valve chamber, resulting in the formation of a frozen plug. The frozen plug plug contains a packed granular bed of magnetically susceptible particles. The plug transfers the
15 upstream pressure load to the walls of the conduit or chamber in the magneto-cryogenic valve, which stops the flow of fluid through the magneto-cryogenic valve and helps to maintain plug integrity.

The magnetically susceptible particles of the injection slurry composition thus can promote the transfer of thermal energy from a flowing fluid of a conduit to the conduit or
20 valve chamber, particularly to a cooled conduit or valve chamber, such as can be achieved by the activation of the heat transfer system of the magneto-cryogenic valve. The magnetically susceptible particles can be positioned by virtue of the magnetic field generating device, particularly to the vicinity of the conduit cooled by the heat transfer system, which promotes adhesion of the frozen fluid plug to the walls of the conduit or
25 valve chamber as well as increasing the rate of deposition of frozen fluid within the conduit or valve chamber onto the wall of the conduit or valve chamber and subsequently onto layers of frozen fluid.

The magnetically susceptible particles of the injection slurry can be selected to have any desired size and/or shape. For example, the particles can be cubes, flakes, granules,
30 cylinders, rings, rods, needles, prisms, disks, fibers, pyramids, spheres, spheroids, prolate spheroids, oblate spheroids, ellipsoids, ovoids, hexahedrons, hexagonal prisms, tetrahedrons, octahedrons, truncated octahedrons, dodecahedrons, triangular prisms or random non-geometric shapes or any combinations of these shapes. The particles also can

be solid or hollow. Hollow rods and spheres are known in the art (*e.g.*, see U.S. Pat. Nos. 5,693,269; 5,322,652; 4,775,598; and 4,565,571). Hollow balls made of a number of different alloys, including stainless steels, and of a wide range of sizes are available from United States Ball Corp. (La Mirada, CA).

5 The magnetically susceptible particles can be or include a partial or complete coating containing a thermally conductive material, such as beryllium, brass, cadmium, carbon steel, chrome nickel steel, cobalt, copper, gold, iridium, iron, lead, magnesium, molybdenum, nickel, platinum, silver, stainless steel, tin or zinc, or any combination or alloy thereof. The magnetically susceptible particles can include a partial or complete
10 coating containing an oxide. The oxide can include an oxide of alumina, aluminum, barium, beryllium, bismuth, chromium, cobalt, copper, gadolinium iridium, iron, magnesium, manganese, molybdenum, nickel, niobium, silica, silicon, silver, tantalum, thorium, tin, titanium, tungsten, vanadium, yttrium, zinc, zirconia or zirconium or combinations thereof.

15 The magnetically susceptible particles can include a partial or complete coating containing corrosion-resistant material. Any corrosion-resistant material known in the art can be used to at least partially coat the magnetically susceptible particles. For example, the magnetically susceptible particles can include a coating containing a corrosion-resistant material, such as zinc, magnesium or cadmium or an alloy of any two or more of these, *e.g.*,
20 a Zn/Mg alloy or a Mg/Cd alloy (*e.g.*, see U.S. Pat. No. 6,399,146).

 The size and/or shape of the particles can be selected to select a surface area of the particle, *e.g.*, to minimize surface area or maximize surface areas, or otherwise facilitate nucleation or formation of frozen fluid within the conduit. Larger particles with lower surface area tend to have higher capacity for containing negative thermal energy. For
25 example, one way to decrease the specific surface area is to select particles that have a more uniform surface geometry. The larger magnetically susceptible particles can be directed to or attracted to an area within the valve chamber, such as the center, to one end, or an inner wall of conduit by means of the magnetic field generating device and effectively increase the surface area of the inner wall of the conduit, promoting transfer of thermal energy out of
30 the fluid within the conduit, to the particles and to the heat transfer unit attached to at least a portion of the conduit.

 Another way to decrease the specific surface area is to increase the particle size. The size of the magnetically susceptible particles, as measured by its characteristic length

(*e.g.*, diameter) and is limited only by the size of the opening of the injector device. The size of the magnetically susceptible particles can be less than 10% the size of the opening of the injector. In some applications, the particle size can be as large as 90% the size of the opening of the injector. The magnetically susceptible particles can have a very broad
5 particle size distribution (*e.g.*, from nanometer sized particles to particles 20 cm in diameter). The magnetically susceptible particles can have a particle size from about 1 nm to about 100 μm . The magnetically susceptible particles can have a particle size greater than 100 μm and less than 5 cm, such as between 1000 μm and 1 cm. The magnetically susceptible particles can have a particle size between 500 μm and 2.5 cm, or between 1500
10 μm and 0.5 cm, or between 0.01 mm and 750 mm, or between 0.1 mm and 500 mm, or between 1 mm and 100 mm, or between 0.5 mm and 50 mm. In some applications, the particles can be microparticles having a diameter less than 100 μm , such as having a diameter between 1 nm and 99 μm . In some applications, the particles can be 1 μm to about 100 μm and can be a part of a magneto-rheological fluid (*e.g.*, see U.S. Pat. Nos. 8,631,917
15 (Piech *et al.*, 2014) and 7,306,083 (Ulicny *et al.*, 2007)). In some applications, the particles can be less than 1 μm , such as from about 1 nm to about 900 nm and can be a part of a ferrofluid (*e.g.*, see U.S. Pat. Nos. 7,063,802 (Tsuda *et al.*, 2006) and 4,356,098 (Chagnon, 1982)).

The injection slurry can include an amount of magnetically susceptible particles in
20 the range of 0.01% to 95% based on the weight of the injection slurry. In some applications, only magnetically susceptible particles are injected, or the amount of magnetically susceptible particles is greater than 95% in the slurry, or the amount of slurry carrier is 1% or less in the slurry. The amount of particles that can be included in the injection composition can depend on the geometry of the particles and their packing in the
25 fluid. The uniformity of the size distribution of the particles also can influence particle packing and thus the amount of particles that can be incorporated, particularly at higher concentrations (*e.g.*, above 75% by weight of the injection slurry).

Single, bimodal and polymodal particle size distributions are acceptable. For
30 example, a combination of particles resulting in a non-uniform particle size distribution can be used. The magnetically susceptible particles can have a very broad particle size distribution (*e.g.*, from nanometer sized particles to particles 20 cm in diameter). In some applications, magnetically susceptible particles having different particle sizes can be selected and injected sequentially into the magneto-cryogenic valve. Particles of different

sizes can be injected at different times. Larger particles could be injected first, followed by progressively smaller particles until the flow through the magneto-cryogenic valve is stopped. In addition to particle size, the shape of the particles also can be changed to create a plug containing a packed granular bed of particles. As an example, magnetically susceptible particles having the following diameters can be selected: a first particle having diameter of about 50% of the diameter of the inlet; a second particle having diameter of about 50% of the diameter of the first particle; a third particle having diameter of about 50% of the diameter of the second particle; a fourth particle having diameter in the range of from 1 to 100 μm ; and a fifth particle having diameter smaller than 1 μm . In an exemplary method, the first particles are injected, followed by the second particles, third particles, fourth particles and fifth particles.

A representation is shown in **Fig. 6B**, where **170a**, **170b**, **170c**, **170d**, and **170e** represent the magnetically susceptible particles of differing particle size. The larger particles **170a** are ensnared in the magnetic fields produced by electromagnetic field generating devices **140** and begin to form a packed granular bed near an end of the valve chamber. The smaller particles **170b** and **170c** subsequently injected also get ensnared by the magnetic fields in the valve chamber and pile up behind the larger particles **170a**. The even smaller particles **170d** and **170e** can percolate through any interstitial spaces between the earlier injected particles and be stopped by the larger particles, although the smaller particles also can be stopped by the magnetic fields. This results in a plug containing a packed granular bed of particles that transfer the upstream pressure load to the walls of the chamber in the magneto-cryogenic valve, which stops the flow of fluid through the magneto-cryogenic valve and helps to maintain plug integrity.

Although sequential injection of smaller and smaller particles is illustrated, particles having different diameters can be injected in any order, and some particles can be injected more than once. For example, referring again to **FIG. 6B**, the injection method could include injection of a mixture of particles **170a** and **170b**, followed by an injection of particles **170d**, followed by an injection of particles **170b**, followed by an injection of particles **170e**. Any combination of particle size and sequence of injection of the particles can be used to form the plug of packed particles. The volume fraction of particles in the valve chamber may increase with time. In the case of nanoparticle injection, the volume fraction of magnetically susceptible particles can be 70% or greater, or 80% or greater, or 90% or greater.

The magnetically susceptible particles of the injector slurry can have a bimodal particle size distribution. In some applications, one mode of the distribution has an average particle size between about 1000 μm and about 17 μm and the other mode of the distribution has an average particle size between about 1 nm and 100 μm .

5 Injecting the magnetically susceptible particles can increase the thermal transfer rate of the plug by more than 50%, or more than 60%, or more than 70%. As described in Example 4, the rate of thermal transfer for a frozen plug of pure oil is less than that of a frozen plug of oil containing magnetically susceptible particles. The results obtained in Example 4 indicate that the magnetically susceptible particles used increased the thermal
10 transfer rate by approximately 70%.

 Selection of a combination of magnetically susceptible particles of differing particle size can allow formation of a plug containing a packed granular bed of particles without the use of any cooling, or without the use of any cryogen. Alternatively, cooling or a cryogen can be used. In some applications, the magnetically susceptible particles can be cooled to
15 cryogenic temperatures prior to injecting the particles. In some applications, the magnetically susceptible particles are in a cryogenic injection composition that includes a cryogen as a carrier and the cryogenic injection composition is injected into the chamber of the magneto-cryogenic valve.

 The cryogenic injection composition can include an amount of magnetically
20 susceptible particles where the total weight of the particle is in the range of 0.05% to at or about 90%, or 0.1% to 85%, or 1% to 80%, or 5% to 75%, or 10% to 70%, or 15% to 65%, or 20% to 60%, or 25% to 50%, or 5% to 25% or 10% to 30%, or 25% to 75%, or 30% to 60%, based on the weight of the injection slurry. The injection slurry can include an amount of magnetically susceptible particles that is 1%, 2%, 3%, 4%, 5%, 6%, 7%, 8%, 9%,
25 10%, 11%, 12%, 13%, 14%, 15%, 16%, 17%, 18%, 19%, 20%, 21%, 22%, 23%, 24%, 25%, 26%, 27%, 28%, 29%, 30%, 31%, 32%, 33%, 34%, 35%, 36%, 37%, 38%, 39%, 40%, 41%, 42%, 43%, 44%, 45%, 46%, 47%, 48%, 49%, 50%, 51%, 52%, 53%, 54%, 55%, 56%, 57%, 58%, 59%, 60%, 61%, 62%, 63%, 64%, 65%, 66%, 67%, 68%, 69%, 70%, 71%, 72%, 73%, 74%, 75%, 76%, 77%, 78%, 79%, 80%, 81%, 82%, 83%, 84%, 85%,
30 86%, 87%, 88%, 89%, 90%, 91%, 92%, 93%, 94% or 95% based on the weight of the inject slurry composition, or the amount of magnetically susceptible particles in the slurry can be in a range of at or about **a** to at or about **b**, where **a** is any one of the preceding percentages of magnetically susceptible particles and **b** is any one of the preceding percentages of

magnetically susceptible particles > **a**, such as from 85% to 95%, or 71% to 91%, or 43% to 93%, etc.

ii. Slurry Carrier

The injection slurry includes a carrier. The carrier can be any fluid compatible with the magnetically susceptible particles. In some instances, the carrier is a cryogen. The cryogen can be a liquid that boils at a temperature colder than -40°C, or colder than -100°C, or colder than -110°C, or colder than -120°C, or colder than -130°C, or colder than -140°C, or colder than -150°C, or colder than -160°C. For example, liquid argon has a boiling point of about -186°C. The cryogen can be liquid nitrogen, liquid oxygen, liquid helium, liquid neon, liquid methane, liquid natural gas, liquid argon, liquid nitrous oxide, liquid carbon dioxide, liquid Freon[®] or combinations thereof. In particular, the cryogen can be liquid argon or liquid nitrogen or a combination thereof.

The injection slurry can include an amount of cryogen in the range of 1% to 99%, or 2% to 95%, or 3% to 90%, or 4% to 85%, or 5% to 75%, or 10% to 70%, or 15% to 65%, or 20% to 60%, or 25% to 50%, or 5% to 25%, or 1% to 10%, or 10% to 40%, based on the weight of the injector slurry composition. The injection slurry can include an amount of cryogen that is 1%, 1.5%, 2%, 2.5%, 3%, 3.5%, 4%, 4.5%, 5%, 5.5%, 6%, 6.5%, 7%, 7.5%, 8%, 8.5%, 9%, 9.5%, 10%, 10.5%, 11%, 11.5%, 12%, 12.5%, 13%, 13.5%, 14%, 14.5%, 15%, 15.5%, 16%, 16.5%, 17%, 17.5%, 18%, 18.5%, 19%, 19.5%, 20%, 20.5%, 21%, 21.5%, 22%, 22.5%, 23%, 23.5%, 24%, 24.5%, 25%, 25.5%, 26%, 26.5%, 27%, 27.5%, 28%, 28.5%, 29%, 29.5%, 30%, 30.5%, 31%, 31.5%, 32%, 32.5%, 33%, 33.5%, 34%, 34.5%, 35%, 35.5%, 36%, 36.5%, 37%, 37.5%, 38%, 38.5%, 39%, 39.5%, 40%, 40.5%, 41%, 41.5%, 42%, 42.5%, 43%, 43.5%, 44%, 44.5%, 45%, 45.5%, 46%, 46.5%, 47%, 47.5%, 48%, 48.5%, 49%, 49.5%, 50%, 50.5%, 51%, 51.5%, 52%, 52.5%, 53%, 53.5%, 54%, 54.5%, 55%, 55.5%, 56%, 56.5%, 57%, 57.5%, 58%, 58.5%, 59%, 59.5%, 60%, 60.5%, 61%, 61.5%, 62%, 62.5%, 63%, 63.5%, 64%, 64.5%, 65%, 65.5%, 66%, 66.5%, 67%, 67.5%, 68%, 68.5%, 69%, 69.5%, 70%, 70.5%, 71%, 71.5%, 72%, 72.5%, 73%, 73.5%, 74%, 74.5%, 75%, 75.5%, 76%, 76.5%, 77%, 77.5%, 78%, 78.5%, 79%, 79.5%, 80%, 80.5%, 81%, 81.5%, 82%, 82.5%, 83%, 83.5%, 84%, 84.5%, 85%, 85.5%, 86%, 86.5%, 87%, 87.5%, 88%, 88.5%, 89%, 89.5%, 90%, 90.5%, 91%, 91.5%, 92%, 92.5%, 93%, 93.5%, 94%, 94.5%, 95%, 95.5%, 96%, 96.5%, 97%, 97.5%, 98%, 98.5%, 99% or 99.5% based on the weight of the injection slurry composition, or the amount of cryogen in the slurry can be in a range of at or about **c** to at or about **d**, where **c** is any one of the

preceding percentages of cryogen and **d** is any one of the preceding percentages of cryogens > **c**, e.g., from 5% to 95%, or 42.5% to 76.5%, or 11% to 41%, etc.

The amount of injection slurry composition injected into the fluid within the conduit can vary and can depend on the composition of the fluid or the rate of flow of the fluid or
5 the size of the conduit or combinations thereof. Thus the exact amount of injection slurry composition added to the fluid depends somewhat on the circumstances. The amount of injection slurry composition added can be expressed in terms of amount of injection slurry composition added per gallon of or liter of fluid. It often is convenient to express the amount of fluid using barrels (or bbl, where bbl=42 US gallons or about 159 L). The
10 amount of fluid in a defined area of the conduit, such as the cooling zone under the attached heat transfer system, can be calculated using standard calculations.

Once a flow rate through the conduit is determined, the amount of injection slurry to be added to the fluid can be calculated. The amount of injection slurry added to the fluid within the conduit can be in the range of 0.01 to 500 pounds/bbl, or in the range of 0.05 to
15 300 pounds/bbl, or in the range of 0.1 to 250 pounds/bbl, or in the range of 0.5 to 125 pounds/bbl, or in the range of 0.75 to 100 pounds/bbl, or in the range of 1 to 100 pounds/bbl.

iii. Solvent

The injection slurry can include a solvent. The solvent can be dispersed on the surface of the magnetically susceptible particles as a film. The solvent can be water or a
20 nonaqueous organic liquid. When the solvent is water, it may freeze upon exposure to the cryogen. The nonaqueous organic liquid may or may not freeze upon exposure to the cryogen. Examples of nonaqueous organic liquids that can be included are benzene, ethyl acetate, propyl acetate, butyl acetate, cyclohexanol, ether, methylethyl ketone, petroleum ether, *n*-hexane, heptane, cyclohexane, naphtha, isopropyl biphenyl, terpene, toluene,
25 xylene, hexamethyl disiloxane, octamethyl cyclotetrasiloxane, diphenyl tetramethyl disiloxane and trimethylsiloxy end-blocked polydimethylsiloxane fluids. The solvent also can be selected from among acetaldehyde, acetone, acetonitrile, acrolein, benzene, benzonitrile, bromo-benzene, butanol, butyl acetate, *n*-butyl amine, *t*-butyl amine, butyl bromide, carbitol acetate, carbon disulfide, carbon tetrachloride, chlorobenzene, chloroform,
30 cyclohexane, cyclohexanone, cyclopentane, *m*-dichlorobenzene, *o*-dichloro-benzene, diethyl carbitol, diethyl ether, dioxane, ethanol, ethyl acetate, ethyl bromide, ethylene glycol, ethyl methyl ketone, glycerin, heptane, heptanone, hexane, hexanol, 1,5-hexadiene, isoamyl acetate, isooctane, isopentane, isopropanol, methanol, methyl cyclohexane, nitroethane,

nitromethane, *n*-octane, octanol, *i*-pentane, *m*-pentane, propanol, propylene glycol, pyridine, toluene, thiophene, trichloroethylene, *m*-xylene, *p*-xylene and combinations thereof. The amount of solvent in the cryogenic injection composition can be in the range of 0.05% to 75%, or 0.1% to 70%, or 0.5% to 60%, or 1% to 50%, or 5% to 25% based on the weight of the injection slurry. The cryogenic injection composition can include an amount of solvent that is 0.01%, 0.05%, 0.1%, 0.5%, 1%, 2%, 3%, 4%, 5%, 6%, 7%, 8%, 9%, 10%, 11%, 12%, 13%, 14%, 15%, 16%, 17%, 18%, 19%, 20%, 21%, 22%, 23%, 24%, 25%, 26%, 27%, 28%, 29%, 30%, 31%, 32%, 33%, 34%, 35%, 36%, 37%, 38%, 39%, 40%, 41%, 42%, 43%, 44%, 45%, 46%, 47%, 48%, 49%, 50%, 51%, 52%, 53%, 54%, 55%, 56%, 57%, 58%, 59%, 60%, 61%, 62%, 63%, 64%, 65%, 66%, 67%, 68%, 69%, 70%, 71%, 72%, 73%, 74% or 75% based on the weight of the injection slurry composition, or the amount of solvent in the slurry can be in a range of at or about **e** to at or about **f**, where **e** is any one of the preceding percentages of solvent and **f** is any one of the preceding percentages of solvent > **e**, such as from 0.01% to 5%, or 0.1% to 74%, or 3% to 33%, etc.

b. Preparation of the Injection Slurry Compositions

The injection slurry composition can be prepared by any method of mixing a fluid with a particle known in the art (*e.g.*, see U.S. Pat. Nos. 7,807,112; 7,785,998 and 7,683,098; and U.S. Pat. Appl. Pub. No. US2011/0085229; US2010/03118598; and US2009/0215255). For example, an injection slurry composition as provided herein can be made by introducing the magnetically susceptible particles to be included in the injection slurry composition into a pressurizable mixing tank. The tank can include cryogen-compatible mixers to stir the liquid cryogen with the magnetically susceptible particles to disperse the particles in the cryogen. The mixing tank can be adapted to include recirculating hoses that include in-line mixers (such as are commercially available from Silverson, Admix, Fluko and other suppliers) compatible with the cryogen and able to withstand cryogenic temperatures to insure thorough mixing of the cryogen with the particles and to assist in dispersion of the particles throughout the cryogen in the composition. Mixing devices, including in-line mixers, are well known in the art (*e.g.*, U.S. Pat. Nos. 5,738,772; 5,076,930; 4,729,664 and 4,533,123).

The cryogenic injection composition also can be made *in situ* by providing an injector tube in which the magnetically susceptible particles are introduced into the liquid cryogen via a one-way ball valve as the liquid cryogen flows past the ball valve, metering in

the magnetically susceptible particles into the cryogen liquid prior to its introduction into the fluid within the conduit.

2. Adhesion Promoter Supply Module

Systems including the magneto-cryogenic valve provided herein can include an
5 adhesion promoter supply module. The adhesion promoter interacts with the fluid in the
conduit making it more prone to adhere to the wall of the conduit or valve chamber. Any
material that tends to make the fluid more prone to adhere to the walls of the conduit or
valve chamber can be used. For example, any material that tends to increase the viscosity
of the fluid can be used in the adhesion promoter composition. Any material that allows the
10 fluid to coat the walls of the conduit or valve chamber also can be included. For example, a
material that reduces the surface tension of the fluid so that the fluid more easily wets the
surface of the conduit or valve chamber in the presence of the material than in its absence.
Surface tension reducers are known in the art.

The adhesion promoter supply module includes pipes or tubing that directly can be
15 connected to the injector of the magneto-cryogenic valve, or the pipes or tubing of the
supply module can be connected to a pump that is connected to the injector of the magneto-
cryogenic valve. Valves between the adhesion promoter module and the injector and/or
between the pump and the injector can be used to modulate the flow of the adhesion
promoter composition through the injector and into the fluid within the conduit. The
20 adhesion promoter supply module can include an in-line mixer. Flow meters can be
included in the pathway between the adhesion promoter supply module and the injector of
the magneto-cryogenic valve to measure the flow rate of the adhesion promoter. In some
applications, a control system operatively adjusts the flow rate of the adhesion promoter
through the adhesion promoter supply module to the injector of the magneto-cryogenic
25 valve.

The flow of the adhesion promoter composition into the injector of the magneto-
cryogenic valve can be modulated by any method known in the art. For example, one or
more valves can be opened to increase flow or closed to decrease flow through the system.
In addition or alternatively, the speed of the pump, when present, can be modulated to
30 module flow of the adhesion promoter through the system and to the injector and ultimately
into the fluid within the conduit.

a. Adhesion Promoter Composition

The adhesion promoter composition can be injected into the fluid in the conduit in order to improve the adherence of the fluid to the wall of the conduit. The adhesion promoter composition also can improve the adherence of the frozen plug of fluid to the wall of the conduit. Any material that tends to make the fluid more prone to adhere to the walls of the conduit can be used. For example, any material that tends to increase the viscosity of the fluid or decrease the surface tension of the fluid within the conduit can be included in the adhesion promoter composition. Surface tension reducers are known in the art. Examples of surface tension reducers include surfactants, sulfonic acids and alkali metal salts of sulfonic acids, alcohols, amines, esters, siloxanes, such as polydimethyl-siloxanes, and mono and dialkylated oxazolines where the alkyl chain length is between about 2 to about 30 carbons. Exemplary sulfonic acids and salts of sulfonic acids include dodecyl benzene sulfonic acid, sodium 1-octane sulfonate, alkyl naphthalene sulfonate. Exemplary alcohols include ethanol, propanol, isopropanol, butanol, hexanol, heptanol, octanol and ethoxylated nonylphenol. The surfactant can include anionic, cationic, nonionic, zwitterionic and/or amphoteric agents and any combination thereof. The surfactant can be a fluorosurfactant. Exemplary esters that can be used as tension reducers include polyols or derivatives of polyols, *e.g.*, glycerin, trimethylolpropane, polyethylene glycol and pentaerythritol. Exemplary amines that can be used as tension reducers include hexakis methoxy methylene melamine.

The amount of surface tension reducer that can be included in the adhesion promoter composition can depend on the composition of the fluid or the rate of flow of the fluid or the size of the conduit or combinations thereof. For example, the amount of surface tension reducer that can be included in the adhesion promoter composition can be between about 0.01% and about 50% based on the weight of the composition. In some applications, the amount of surface tension reducer in the composition can be between 0.1% and 25%, or between 0.5% and 20%, or between 1% and 10%, or between 0.005% and 5%. The adhesion promoter composition can include an amount of surface tension reducer that is 0.001%, 0.005%, 0.01%, 0.05%, 0.1%, 0.5%, 1%, 2%, 3%, 4%, 5%, 6%, 7%, 8%, 9%, 10%, 11%, 12%, 13%, 14%, 15%, 16%, 17%, 18%, 19%, 20%, 21%, 22%, 23%, 24%, 25%, 26%, 27%, 28%, 29%, 30%, 31%, 32%, 33%, 34%, 35%, 36%, 37%, 38%, 39%, 40%, 41%, 42%, 43%, 44%, 45%, 46%, 47%, 48%, 49% or 50% based on the weight of the adhesion promoter composition, or the amount of surface tension reducer can be in a range of at or about **g** to at

or about **h**, where **g** is any one of the preceding percentages of surface tension reducer and **h** is any one of the preceding percentages of surface tension reducer > **g**, e.g., from 0.001% to 0.5%, or 1% to 47%, or 5% to 15%, etc.

It has been determined that introduction of surfactant into the fluid within the
5 conduit tends to provide a more uniform frozen fluid and can serve as an adhesion
promoter. Any surfactant known in the art can be used, including cationic, anionic, non-
ionic and zwitterionic surfactants, including silicone surfactants. Exemplary surfactants are
discussed in the art (e.g., see U.S. Pat. Nos. 3,760,598; 4,634,050; 6,464,148; and
7,562,831, and particularly U.S. Appl. Pub. No. 2011/0308259, paragraphs [0234]-[0238],
10 the disclosure of each of which is incorporated by reference herein).

Exemplary amphoteric surfactants include betaines, sulphobetaines, imidazoline
betaines and alkyl amido propyl betaines. Exemplary nonionic surfactants include
ethoxylated nonionic surfactants selected from among condensation products of ethylene
oxide with aliphatic alcohols having from 8 to 22 carbon atoms in either straight or
15 branched chain configuration as well as condensation products of ethylene oxide with nonyl
phenol, phenol, butyl phenol, di-nonyl phenol, octyl phenol or other phenols, sorbitan esters
and amine oxides, ethoxylated C₁₀-C₂₀ alcohols, fatty acids, fatty amines or glyceryl esters,
alkyl polyglycosides, methyl glucoside esters, as well as blends of such nonionic
surfactants. Other exemplary non-ionic surfactants include Tergitol NP-9® (Dow Chemical
20 Co., Midland, MI), a nonionic, nonylphenol ethoxylate surfactant, Tergitol NP-33 [9016-45-
9] an alpha(nonylphenyl)-omega-hydroxypoly(oxy-1,2-ethanediyl); antarox;
nonylphenoxypoly(ethyleneoxy)ethanol; nonylphenyl polyethyleneglycol ether, nonionic;
nonylphenyl polyethylene glycol ether; PEG-9 nonyl phenyl ether; POE (10) nonylphenol;
POE (14) nonylphenol; POE (15) nonyl phenol; POE(15) Nonyl Phenyl Ether; POE(18)
25 Nonyl Phenyl Ether; POE (20) nonylphenol; POE(20) Nonyl Phenyl Ether; POE (30)
nonylphenol; POE (4) nonylphenol; POE (5) nonylphenol; POE (6) nonylphenol; POE (8)
nonylphenol; polyethylene glycol 450 nonyl phenyl ether; polyethylene glycol 450 nonyl
phenyl ether, nonionic surfactant; polyethylene glycols mono(nonylphenyl)ether;
polyethylene mono(nonylphenyl)ether glycols; polyoxy-ethylene (10) nonylphenol;
30 polyoxyethylene (14) nonylphenol; polyoxyethylene (1.5) nonyl phenol; polyoxyethylene
(20) nonylphenol; polyoxyethylene (30) nonylphenol; polyoxyethylene (4) nonylphenol;
polyoxyethylene (5) nonylphenol; polyoxyethylene (6) nonylphenol; polyoxyethylene (8)
nonylphenol; Polyoxyethylene (9) Nonylphenyl Ether; polyoxyethylene(n)-nonylphenyl

ether; Polyoxyethylene nonylphenol; POE nonylphenol; Protachem 630; Sterox; Surfionic N; T-DET-N; Tergitol NP; Tergitol NP-14; Tergitol NP-27; Tergitol NP-33; Tergitol NP-35; Tergitol NP-40; Tergitol NPX; Tergitol TP-9; Tergitol TP-9 (non-ionic); Triton N; Triton X; Dowfax 9N; ethoxylated nonylphenol; glycols, polyethylene, mono(nonyl-phenyl) ether; Igepal CO; Igepal CO-630; macrogol nonylphenyl ether; Makon; Neutronyx 600; Nonipol NO; nonoxinol; nonoxynol; Nonoxynol-15; Nonoxynol-18; Nonoxynol-20; nonyl phenol ethoxylate; nonylphenol polyethylene glycol ether; nonylphenol, polyoxyethylene ether; nonyl-phenoxypoly-ethoxyethanol; nonionic surfactants having a polyalkylene oxide polymer as a portion of the surfactant molecule, such as chlorine-, benzyl-, methyl-, ethyl-, propyl-, butyl-and other similar alkyl-capped polyethylene glycol ethers of fatty alcohols; polyalkylene oxide free nonionics such as alkyl polyglycosides; sorbitan and sucrose esters and their ethoxylates; alkoxyated ethylene diamine; alcohol alkoxyates such as alcohol ethoxylate propoxylates, alcohol propoxylates, alcohol propoxylate ethoxylate propoxylates, alcohol ethoxylate butoxylates; nonylphenol ethoxylate, polyoxyethylene glycol ethers; carboxylic acid esters such as glycerol esters, polyoxyethylene esters, ethoxylated and glycol esters of fatty acids; carboxylic amides such as diethanolamine condensates, monoalkanolamine condensates, polyoxyethylene fatty acid amides; and polyalkylene oxide block copolymers including an ethylene oxide/propylene oxide block copolymer such as those commercially available under the trademark PLURONIC® (BASF-Wyandotte).

Exemplary anionic surfactants include alkali metal alkyl sulfates, alkyl or alkylaryl sulfonates, linear or branched alkyl ether sulfates and sulfonates, alcohol polypropoxylated and/or polyethoxylated sulfates, alkyl or alkylaryl disulfonates, alkyl disulfates, alkyl sulphosuccinates, alkyl ether sulfates, linear and branched ether sulfates and mixtures thereof.

Exemplary cationic surfactants include arginine methyl esters, alkanolamines and alkylenediamides, and mixtures thereof. Other exemplary cationic surface active agents include but are not limited to homopolymers and copolymers derived from free radically polymerizable acrylic or methacrylic ester or amide monomers. The copolymers can contain one or more units derived from acrylamides, methacrylamides, diacetone acrylamides, acrylic or methacrylic acids or their esters, vinyl lactams such as vinyl pyrrolidone or vinyl caprolactam, and vinyl esters. Exemplary polymers include copolymers of acrylamide and dimethyl amino ethyl methacrylate quaternized with dimethyl sulfate or with an alkyl halide; copolymers of acrylamide and methacryloyl

oxyethyl trimethyl ammonium chloride; the copolymer of acrylamide and methacryloyl
oxyethyl trimethyl ammonium methosulfate; copolymers of vinyl pyrrolidone/dialkyl-
aminoalkyl acrylate or methacrylate, optionally quaternized, such as the products sold under
the name GAFQUAT™ by International Specialty Products; the dimethyl amino ethyl
5 methacrylate/vinyl caprolactam/vinyl pyrrolidone terpolymers, such as the product sold
under the name GAFFIX™ VC 713 by International Specialty Products; the vinyl
pyrrolidone/methacrylamidopropyl dimethylamine copolymer, marketed under the name
STYLEZE™ CC 10 by International Specialty Products; and the vinyl pyrrolidone and
quaternized dimethyl amino propyl methacrylamide copolymers such as the product sold
10 under the name GAFQUAT™ HS 100 by International Specialty Products; quaternary
polymers of vinyl pyrrolidone and vinyl imidazole such as the products sold under the trade
name Luviquat® (product designation FC 905, FC 550, and FC 370) by BASF;
acetamidopropyl trimonium chloride, behenamidopropyl dimethylamine, behenamido-
propyl ethyldimonium ethosulfate, behentrimonium chloride, cetethyl morpholinium
15 ethosulfate, cetrimonium chloride, cocoamidopropyl ethyl-dimonium ethosulfate, dicetyl-
dimonium chloride, dimethicone hydroxypropyl trimonium chloride, hydroxyethyl
behenamidopropyl diammonium chloride, quaternium-26, quaternium-27, quaternium-53,
quaternium-63, quaternium-70, quaternium-72, quaternium-76 hydrolyzed collagen, PPG-9
diethylammonium chloride, PPG-25 diethylammonium chloride, PPG-40 diethylmonium
20 chloride, stealkonium chloride, stearamidopropyl ethyl dimonium ethosulfate,
steardimonium hydroxypropyl hydrolyzed wheat protein, steardimonium hydroxypropyl
hydrolyzed collagen, wheat germamido-propalkonium chloride, wheat germamidopropyl
ethyldimonium ethosulfate, polymers and copolymers of dimethyl diallyl ammonium
chloride, such as Polyquaternium-4, Polyquaternium-6, Polyquaternium-7, Polyquaternium-
25 10, Polyquaternium-11, Polyquaternium-16, Polyquaternium-22, Polyquaternium-24,
Polyquaternium-28, Polyquaternium-29, Polyquaternium-32, Polyquaternium-33,
Polyquaternium-35, Polyquaternium-37, Polyquaternium-39, Polyquaternium-44,
Polyquaternium-46, Polyquaternium-47, Polyquaternium-52, Polyquaternium-53,
Polyquaternium-55, Polyquaternium-59, Polyquaternium-61, Polyquaternium-64,
30 Polyquaternium-65, Polyquaternium-67, Polyquaternium-69, Polyquaternium-70,
Polyquaternium-71, Polyquaternium-72, Polyquaternium-73, Polyquaternium-74,
Polyquaternium-76, Polyquaternium-77, Polyquaternium-78, Polyquaternium-79,
Polyquaternium-80, Polyquaternium-81, Polyquaternium-82, Polyquaternium-84,

Polyquaternium-85, Polyquaternium-87, PEG-2-cocomonium chloride, and mixtures thereof; polyalkyleneimines such as polyethyleneimines, polymers containing vinyl pyridine or vinyl pyridinium units, condensates of polyamines and epichlorhydrins; quaternary polyurethanes; salts of a primary, secondary, or tertiary fatty amine, optionally
5 polyoxyalkylenated; a quaternary ammonium salt derivative of imidazoline, or an amine oxide; mono-, di-, or tri-alkyl quaternary ammonium compounds with a counterion such as a chloride, methosulfate, tosylate, including, but not limited to, cetrimonium chloride, dicytididimonium chloride and behentrimonium methosulfate.

Silicone surfactants also can be used. For example, in some embodiments, the
10 silicone surfactant includes a surface active polydiorganosiloxane, such as described in U.S. Pat. No. 4,421,656. In some embodiments, the silicone surfactant can be selected from among dimethicone copolyols and alkyl dimethicone copolyols and blends thereof. Examples of such silicone surfactants include the blends of dimethicone copolyol and cyclomethicone, such as sold by Dow Corning (Midland, MI) under the name DC3225C or
15 DC2-5225C, a polyalkyl polyether polysiloxane copolymer having an alkyl radical containing from 5 to 22 carbon atoms, such as cetyl dimethicone copolyol, such as that sold under the name Abil® EM-90 by EVONIK Goldschmidt GmbH (Essen, Germany), the mixture of dimethicone copolyol and cyclopentasiloxane (85/15), such as that sold under the name Abil® EM-97 by Goldschmidt, linear-type polyether-modified silicone emulsifiers,
20 including methyl ether dimethicones, such as PEG-3 methyl ether dimethicones, PEG-9 methyl ether dimethicones, PEG-10 methyl ether dimethicones, PEG-11 methyl ether dimethicones, and butyl ether dimethicones (available from Shin-Etsu (Akron, Ohio); branched-type polyether-modified silicone emulsifiers, such as PEG-9 polydimethylsiloxyethyl dimethicone (Shin-Etsu), alkyl co-modified branched-type
25 polyether silicones, such as lauryl PEG-9 polydimethylsiloxyethyl dimethicone (Shin-Etsu), silicones containing polyalkylene oxide groups, such as the commercially available emulsifier Silwet® 7001, manufactured by Momentive Performance Materials (Albany, NY), Dow Corning FG-10, Silwet® L-77 (polyalkylene oxide modified heptamethyl trisiloxane containing a methyl end group and 1 pendant group and having an average
30 molecular weight of 645) and Silwet® L-7608 (polyalkylene oxide modified heptamethyl trisiloxane containing a hydrogen end group and one pendant group and having an average molecular weight of 630) available from Momentive Performance Materials; Lambent™ MFF-199-SW (containing a hydrogen end group and one pendant polyethylene oxide group

and having an average molecular weight between 600 to 1000) available from Lambent Technologies Inc. (Gurnee, Illinois); silicone copolyol based carboxylate esters, such as SW-CP-K (containing a phthalate end group and one polyethylene oxide pendant group and having an average molecular weight between 800 and 1100) and Lube CPI (containing a
5 phthalic acid end group and 3 to 5 pendant groups and having an average molecular weight between 2900 and 5300) available from Lambent Technologies Inc.; alkyl-dimethicone copolyol type surfactants, such as described in U.S. Pat. No. 7,083,800, including such silicone emulsifiers commercially sold under the names "Abil® WE 09", "Abil® WS 08" and "Abil® EM 90" (EVONIK Goldschmidt GmbH, Essen, Germany) and cationic silicone
10 emulsifiers, such as described in U.S. Pat. No. 5,124,466.

Anionic surfactants include, but are not limited to, one or more of a carboxylate such as, without limitation, alkylcarboxylates (*e.g.*, carboxylic acid and/or its salts), polyalkoxycarboxylates (*e.g.*, polycarboxylic acid and/or its salts), alcohol ethoxylate carboxylates, nonylphenol ethoxylate carboxylates, or combinations thereof; sulfonates such
15 as, without limitation, alkylsulfonates, alkylbenzenesulfonates (*e.g.*, dodecyl benzene sulfonic acid and/or its salts), alkylarylsulfonates, sulfonated fatty acid esters, or combinations thereof; sulfates such as, without limitation, sulfated alcohols, sulfated alcohol ethoxylates, sulfated alkylphenols, alkylsulfates, sulfosuccinates, alkylether sulfates, or combinations thereof; phosphate esters such as, without limitation, alkyl-phosphate esters; or
20 combinations thereof. Exemplary anionic surfactants include sodium alkylarylsulfonate, alpha-olefinsulfonate, fatty alcohol sulfates and combinations thereof.

Exemplary amphoteric surfactants (or zwitterionic surfactants) include, but are not limited to, imidazoline derivatives, betaines, imidazolines, sultaines, propionates, amine oxides or combinations thereof, including imidazolinium betaine, dimethylalkyl lauryl
25 betaine, alkylglycine, and alkyldi(aminoethyl)glycine.

The amount of surfactant can be included in the adhesion promoter composition can depend on the composition of the fluid or the rate of flow of the fluid or the size of the conduit or combinations thereof. For example, the amount of surfactant that can be included in the adhesion promoter composition can be between about 0.01% and about 50%
30 based on the weight of the composition. In some applications, the amount of surfactant in the composition can be between 0.1% and 25%, or between 0.5% and 20%, or between 1% and 10%, or between 0.005% and 5%. The adhesion promoter composition can include an amount of surfactant that is 0.001%, 0.005%, 0.01%, 0.05%, 0.1%, 0.5%, 1%, 2%, 3%, 4%,

5 5%, 6%, 7%, 8%, 9%, 10%, 11%, 12%, 13%, 14%, 15%, 16%, 17%, 18%, 19%, 20%, 21%, 22%, 23%, 24%, 25%, 26%, 27%, 28%, 29%, 30%, 31%, 32%, 33%, 34%, 35%, 36%, 37%, 38%, 39%, 40%, 41%, 42%, 43%, 44%, 45%, 46%, 47%, 48%, 49% or 50% based on the weight of the adhesion promoter composition, or the amount of surfactant can be in a range of at or about *i* to at or about *j*, where *i* is any one of the preceding percentages of surfactant and *j* is any one of the preceding percentages of surfactant > *j*, such as from 0.001% to 0.5%, or 0.5% to 50%, or 0.05% to 15%, etc.

10 As discussed above, the amount of surfactant included in the adhesion promoter composition to be injected into the fluid within the conduit can vary and can depend on the composition of the fluid or the rate of flow of the fluid or the size of the conduit or combinations thereof and thus the exact amount of surfactant added depends somewhat on the circumstances. The amount of surfactant added can be expressed in terms of amount of surfactant added per gallon of or liter of fluid. The amount of fluid in a defined area of the conduit, such as the cooling zone under the attached heat transfer system, can be calculated
15 using standard calculations. Because flow rates through conduits can vary, it often is convenient to express the amount of fluid in barrels or bbl. The amount of surfactant added to the fluid within the conduit, either by injecting a cryogenic injection composition containing frozen beads that include surfactant(s) or by injection of surfactant into the fluid within the conduit, can be in the range of 0.01 to 150 pounds/bbl or in the range of 0.1 to
20 100 pounds/bbl or in the range of 0.5 to 75 pounds/bbl or in the range of 1 to 65 pounds/bbl, or in the range of 1.5 to 50 pounds/bbl, or in the range of 1 to 10 pounds/bbl. Inorganic and organic particles, such as clay minerals and diatomaceous earth, also can be included in the adhesion promoter composition.

25 The adhesion promoter composition can include a solvent. The solvent can be selected from among any known solvent. Exemplary solvents include acetaldehyde, acetone, acetonitrile, acrolein, benzene, benzonitrile, bromo-benzene, butanol, butyl acetate, *n*-butyl amine, *t*-butyl amine, butyl bromide, carbitol acetate, carbon disulfide, carbon tetrachloride, chlorobenzene, chloroform, cyclohexane, cyclohexanone, cyclopentane, *m*-dichlorobenzene, *o*-dichloro-benzene, diethyl carbitol, diethyl ether, dioxane, ethanol, ethyl acetate, ethyl
30 bromide, ethylene glycol, ethyl methyl ketone, glycerin, heptane, heptanone, hexane, hexanol, 1,5-hexadiene, isoamyl acetate, isooctane, isopentane, isopropanol, methanol, methyl cyclohexane, nitroethane, nitromethane, *n*-octane, octanol, *i*-pentane, *m*-pentane,

propanol, propylene glycol, pyridine, toluene, thiophene, trichloroethylene, water, *m*-xylene, *p*-xylene and combinations thereof.

The amount of solvent in the adhesion promoter composition can be in the range of 0.05% to 85%, 0.1% to 80%, or 0.5% to 75%, or 1% to 50%, or 5% to 50%, or 5% to 25%,
5 or 1% to 15%, or 0.5% to 10%, or 0.05% to 5%, based on the weight of the adhesion promoter composition. The adhesion promoter composition can include an amount of solvent that is 0.001%, 0.005%, 0.01%, 0.05%, 0.1%, 0.5%, 1%, 2%, 3%, 4%, 5%, 6%, 7%, 8%, 9%, 10%, 11%, 12%, 13%, 14%, 15%, 16%, 17%, 18%, 19%, 20%, 21%, 22%, 23%,
10 24%, 25%, 26%, 27%, 28%, 29%, 30%, 31%, 32%, 33%, 34%, 35%, 36%, 37%, 38%, 39%, 40%, 41%, 42%, 43%, 44%, 45%, 46%, 47%, 48%, 49%, 50%, 51%, 52%, 53%, 54%, 55%, 56%, 57%, 58%, 59%, 60%, 61%, 62%, 63%, 64%, 65%, 66%, 67%, 68%, 69%, 70%, 71%, 72%, 73%, 74%, 75%, 76%, 77%, 78%, 79%, 80%, 81%, 82%, 83%, 84% or 85%, based on the weight of the adhesion promoter composition, or the amount of solvent can be in a range of at or about **k** to at or about **l**, where **k** is any one of the
15 preceding percentages of solvent and **l** is any one of the preceding percentages of solvent > **k**, such as from 0.001% to 1%, or 0.1% to 84%, or 5% to 45%, etc.

3. Cryogen Supply Module

In some instances, the magneto-cryogenic valve includes a heat transfer system that includes a cryogen. In such instances, the system includes a cryogen supply module. A
20 cryogen supply module provides a cryogen to the heat transfer system. The cryogen supply module can include a non-thermally conducting surface in contact with the environment to thermally isolate the cryogen supply module from the environment. The cryogen supply module can be constructed of a material appropriate for the environment in which it is to be deployed. For example, in embodiments where the system is to be used underwater,
25 particularly in deep sea drilling applications, the cryogen supply module can be constructed of material sufficient to withstand the pressures at depth, including the pressures exerted by water at depths of 5,000 feet or more under water. Those skilled in the art of undersea construction are familiar with the required mechanics necessary for the construction of a cryogen supply module capable of containing a cryogen and withstanding the ambient water
30 pressures at depth. For example, the cryogen supply module can be constructed of reinforced steel or composite materials and reinforced to withstand the ambient water pressures.

Piping, valves, vessels and other components of the cryogen supply module can be designed for the expected pressures and temperatures, such as to industry standards, *e.g.*, specifications promulgated by the American Society of Mechanical Engineers (ASME). The cryogen supply module includes a cryogenic storage tank or other vessel constructed to contain liquid cryogen. In most instances, the storage tank contains an inner vessel for
5 containing the liquid cryogen and an outer vessel exposed to the environment, where the inner vessel is designed to minimize any thermal transfer from the outer vessel to the inner vessel. The cryogen supply module also includes pipes or tubes for providing cryogen to the heat transfer system, and can include pipes or tubing for charging the storage tank with
10 cryogen.

In some applications, a pressure control manifold is present in the cryogen supply module to control the pressure at which the cryogen is provided to the heat transfer system. The pressure control manifold can be used to maintain or adjust the thermal transfer in the heat transfer system. In an evaporative heat transfer system such as can be established
15 using a liquid cryogen, *e.g.*, liquid nitrogen or liquid argon, the evaporation of the liquid cryogen into a gas is effective for thermal energy transfer, but the resulting gas can serve as an insulating layer, thereby reducing the effectiveness of thermal energy transfer. By adjusting the pressure of the cryogen supply to the heat transfer system, the resulting gas from the warmed cryogen can be removed from the heat transfer system by the force of the
20 incoming cryogen, removing the insulating layer of gas, thereby increasing the rate of thermal energy removal from the system.

The cryogen supply module can provide fluid cryogen to the heat transfer system directly through pipes or tubing or the cryogen supply module can be connected to a pump that is connected to the heat transfer system. The cryogen supply module can include
25 thermal monitoring devices for monitoring the temperature of the cryogen or the pipes carrying the cryogen or a combination thereof. The cryogen supply module also can include flow rate meters for determining flow of cryogen from the module. The cryogen supply module also can include level meters for monitoring the amount of cryogen in the module.

The cryogen supply module contains cryogen and delivers the cryogen to the heat
30 transfer system of the magneto-cryogenic valve. Any cryogen known in the art can be used. The cryogen can include any liquid that can transfer thermal energy under the conditions of use. Exemplary liquid cryogens can include liquid carbon dioxide, liquid ammonia, liquified chlorofluorohydrocarbons, liquified gases such as liquid nitrogen, liquid oxygen,

liquid neon, liquid argon, liquid nitrous oxide, hydrofluoroethane, pentafluoropropane, trichloromonofluoromethane, dichlorodifluoromethane, or a mixture or any combination thereof. In some instances, a cryogen having a boiling temperature of -40°C or less is selected. In some instances, a cryogen having a boiling temperature of -150°C or less is selected. In some instances, the cryogen is selected to have a boiling temperature less than -40°C , or -50°C , or -60°C , or -70°C , or -80°C , or -90°C , or -100°C , or -110°C , or -120°C , or -130°C , or -140°C , or -150°C , or -160°C , or -170°C , or -180°C , or -190°C , or -200°C . In some applications, the cryogen is liquid nitrogen or liquid argon or a combination thereof.

In some applications, a pressure control manifold is present at the outlet port of the heat transfer system to control the pressure of the cryogen within the heat transfer system. The pressure control manifold can be used to adjust the thermal transfer in the heat transfer system. When rapid thermal energy extraction (cooling) is desired, the pressure control manifold is configured so that the pressure within the heat transfer system is close to ambient pressure, promoting the evaporation of the liquid cryogen into its gaseous state, thereby quickly removing thermal energy due to evaporative cooling. If it is desirable to decrease the rate of cooling, the pressure control manifold can be adjusted to increase the pressure within the heat transfer system. As the pressure inside the heat transfer system increases, evaporative cooling that normally can be achieved by the conversion of liquid cryogen into a gas at atmospheric pressures is slowed or prevented, depending on the pressure within the heat transfer system. When the pressure is high, it is possible for latent heat to be drawn from the fluid inside the conduit by a liquid cryogen in the heat transfer system, but the liquid cryogen cannot be converted into a gas, and thus thermal transfer from the fluid in the conduit to the liquid cryogen is not as high as can be achieved under lower pressure conditions. In some instances, modulating the pressure so that it is increased at a controlled rate can result in a controlled modulation of the temperature within the heat transfer system, allowing for the control of temperature within the heat transfer system by modulating the pressure of the cryogen within the heat transfer system. Thus, one can vary the temperature by varying the pressure within the heat transfer system. A controllable temperature rise in the heat transfer system can be used to donate thermal energy to the conduit in contact with the heat transfer system, providing for a controlled melting of the frozen plug within the conduit.

a. Tubing or piping

The cryogen supply module, and pumps and valves when present, are in fluid communication and can be connected via tubing or piping. The tubing or piping can be constructed of a material and construction applicable for the environment in which the system is to be deployed. For example, for deep sea drilling applications, the tubing or piping can be engineered to resist the high water pressures that exist at depths of deep sea drilling. Those skilled in the art can select the proper material and thickness or design of the piping or tubing for such applications. The piping or tubing can include radial or lateral reinforcements to withstand collapse under the pressure of the water pressures that exist at deep sea drilling depths. The piping or tubing can be manufactured to be of a thickness such that the piping or tubing is resistant to deformation or crushing by the water pressure at sea depths of deep sea drilling. The tubing can be constructed for ambient pressures and can be insulated to minimize thermal contamination from the surrounding environment. The tubing can be thermally insulated from the environment using any technique known to those of skill in the art. In some embodiments, the tubing or piping can be encircled or enveloped in a non-thermally conductive material. In some embodiments, the piping or tubing can include coaxial tubing in which the inner pipe or tube is within an outer pipe or tube, and the space between the inner pipe or tube and the outer pipe or tube includes a thermally non-conductive material as insulation. Any thermally non-conductive material known in the art can be used.

b. Flow rate meters

In some embodiments, flow rate meters can be included in the systems provided herein, *e.g.*, in the pipes or tubing that deliver cryogen to the heat transfer system. One or more flow rate meters can be positioned in the fluid path between the cryogen supply module and the heat transfer system to measure the total fluid flow through the system. The flow meter can be selected from among coriolis force flow meters, electromagnetic velocity sensors, magnetic flow meters, optical sensors, thermal flow meters, turbine flow meters, ultrasonic flow meters or any other type of flow meter known in the art (*e.g.*, see U.S. Pat. Nos. 7,730,777; 7,707,898; 4,934,196; 4,422, 338 and RE 31,450, and U.S. Pat. Appl. Pubs. 2009-0281671, 2005-0288873 and 2004-0244498). The flow rate meters can be in communication with a computer module for automation of the system. Data from the flow rate meters can be used to determine the flow of cryogen through the system, particularly through the heat transfer system, and can be used to modulate the rate of flow of cryogen

through the system, either manually or via computer control. Flow rate meters can be included throughout the path of fluid communication from the cryogen supply module to the point of discharge of spent cryogen from the heat transfer system for determination of rate of flow of cryogen.

5 **c. Modulating Valves**

The cryogen supply module also can include modulating valves that can be used to modulate the flow of cryogen from the cryogen supply module to the heat transfer system of the magneto-cryogenic valve. In some applications, one or more modulating valves can be positioned between the cryogen supply module and a pump, if present, or the heat transfer
10 system, or a combination thereof. The modulating valves can be controlled manually. The modulating valves can include electrical solenoid valves. The modulating valves can be in communication with and/or controlled by a computer. The computer can modulate the flow of cryogen through the system by opening or closing the modulating valves or adjusting the degree to which one or more of the modulating valves are open and allowing refrigerant
15 flow through the system.

4. Computer module

In some applications, the system includes a computer module for automation of the system. The computer module can be in communication with and/or in control of any part of the magneto-cryogenic valve or element of the system containing the magneto-cryogenic
20 valve. The computer module can be used to control the magnetic field generating device and its related elements, or the cryogen supply module and its related element, or the injector slurry module and its related elements, or the adhesion promoter composition supply module and its related elements, or any combination thereof.

Communications between the computer module and the magneto-cryogenic valve or any
25 element of the system containing the magneto-cryogenic valve can be performed using any suitable technique, including electromagnetic (EM) signaling, mud-pulse telemetry, switched packet networking, or connection-based electronic signaling. The communications medium can be a wire, a cable, a waveguide, a fiber, a fluid such as mud, or any other medium. The communications medium can include one or more
30 communications paths. For example, one communications path can couple the computer module to a heat transfer system while another communications path can couple the computer module to a cryogen supply module. The communications medium also can be used to convey data, such as temperature or pressure sensor measurements. For example,

measurements from temperature sensors attached to the conduit can be sent to the computer module for further processing or analysis or storage. The communications medium can permit communications at a speed sufficient to allow the computer module to perform real-time collection and analysis of data from sensors located downhole or elsewhere associated with the magneto-cryogenic valve or the system containing the magneto-cryogenic valve.

The methods provided herein can be embodied in a computer-readable storage medium having a computer-readable program embodied therein for directing operation of the described magneto-cryogenic valve or the system containing the magneto-cryogenic valve. The computer-readable program can include instructions for operating the magneto-cryogenic valve or the system containing the magneto-cryogenic valve.

For example, the computer processor of the computer module can control and/or modulate the flow of the cryogen through the heat transfer system by manipulating one or more valves in the path of fluid flow from the cryogen supply module to the heat transfer system. Remotely activatable or controllable modulating valves, such as electrical solenoid valves, can be under the control of the computer. For example, the computer can deactivate one or more electrical solenoid valve(s) to modulate cryogen flow through the heat transfer system. The computer module also can monitor and/or record temperatures throughout the system. The temperature inside the heat transfer system and the temperature along the conduit, particularly in the vicinity of the heat transfer system, can be monitored with thermal monitoring devices, such as thermocouples, in communication with the computer module.

D. METHODS

Provided herein are methods of reversibly modulate flow through a conduit. The magneto-cryogenic valve and systems including the magneto-cryogenic valve provided herein can be used to reversibly modulate the flow of a fluid through a conduit. When the magneto-cryogenic valve and systems containing the magneto-cryogenic valve described herein are used, *e.g.*, when magneto-cryogenic valve integrated or attached to a fluid-filled conduit is activated, the magneto-cryogenic valve can input sufficient negative thermal energy and extract heat from the fluid and the conduit, to decrease the temperature of the fluid within the conduit, which will thicken and eventually solidify. The methods provided herein can result in reduction of the temperature of the at least a portion of the fluid of the conduit to a temperature of between -20°C to -200°C . In some methods, the temperature of the fluid of the conduit can be decreased to a temperature of -150°C or lower.

Activation of the magneto-cryogenic valve results in the addition of a large sink of negative thermal energy by virtue of the introduction of the injection slurry composition containing magnetically susceptible beads into the fluid within the conduit or valve chamber. Activation also results in thermal energy extraction from the conduit and fluid
5 therein by the heat transfer system attached to at least a portion of the conduit or valve chamber. Activation also results in the production of magnetic fields that interact with the magnetically susceptible beads and direct them to a desired location within the conduit or valve chamber, *e.g.*, an inner wall of the conduit or valve chamber, generally in the vicinity of the heat transfer system. This combination of negative energy input via the injection
10 slurry composition and heat extraction via the heat transfer system results in concentric freezing of the fluid, such as a fluid containing crude oil or other petroleum product, within the reduced temperature zone of the conduit or valve chamber (usually in the vicinity of the heat transfer system), continually reducing the inside diameter of the conduit or valve chamber and ultimately forming a plug adhered to the conduit or valve chamber inner wall
15 that seals the conduit with the frozen plug. The plug can be maintained attached to the conduit or valve chamber wall to prevent flow for as long as desired, *e.g.*, until the conduit is repaired. The attachment of the plug can be prolonged by maintaining a reduced temperature in the vicinity of the attachment site of the plug to the conduit or valve chamber. In some methods, the heat transfer system includes a thermoelectric module or a
20 Peltier device. In some methods, the heat transfer system includes a cryogen cooled heat exchange unit as described herein.

The methods provided herein include injecting into a fluid within the conduit an injection slurry composition, which contains magnetically susceptible particles. The injection slurry composition also can contain other components, such as a carrier, including
25 a cryogen and solvent and combinations thereof. The introduction of the injection slurry composition reduces the time required for frozen plug formation because it results in a large influx of negative thermal energy into the fluid within the conduit. In addition, the discrete particles of negative thermal energy can absorb heat from the fluid and, by virtue of the interaction of the magnetically susceptible particles with the magnetic field produced by the
30 magnetic field generating device, the thermal energy from the fluid absorbed by the magnetically susceptible particles can be transferred to the heat transfer system by virtue of the particles being directed, *e.g.*, to the inner conduit or valve chamber wall in the vicinity of the heat transfer system by the attractive force of the magnetic fields. Hence, the

removal of thermal energy from the fluid occurs at an increased rate of thermal energy dissipation from the fluid than that observed with injection of cryogen alone. The magnetically susceptible particles pre-cooled to a temperature below the freezing point of the fluid within the conduit accelerate the decrease in temperature of the fluid and its
5 solidification and freezing. The direction of chilled fluid to the vicinity of the pre-cooled conduit near the heat transfer system due to the attractive forces of the magnetic fields on the magnetically susceptible particles also accelerates the rate of formation of a frozen plug of fluid in the conduit or valve chamber.

In addition, the pre-cooled magnetically susceptible particles also can result in
10 formation of localized viscosity increases in the fluid and/or partially solidified fluid. Accumulation of partially solidified fluid on the magnetically susceptible particles can rapidly be directed to any desired location, *e.g.*, the conduit or valve chamber walls by virtue of the magnetic fields of the magnetic field generating device, thereby accelerating the rate of formation of a frozen plug of fluid in the conduit or valve chamber. Accordingly,
15 formation of a frozen plug occurs in significantly less time using the systems and methods described herein than when a cryogen alone is injected into the fluid in a conduit.

It has been determined that the introduction of an adhesion promoter composition into the fluid of the conduit tends to provide a more uniform frozen fluid or to promote adhesion of the frozen plug to the conduit or valve chamber inner wall or both. In the
20 methods provided herein, the adhesion promoter composition can include any surface tension reducer known in the art. Examples of surface tension reducers include surfactants, sulfonic acids and alkali metal salts of sulfonic acids, alcohols, amines, esters, siloxanes, such as polydimethylsiloxanes, and mono and dialkylated oxazolines where the alkyl chain length is between about 2 to about 30 carbons. The adhesion promoter composition can be
25 injected into the fluid at a point remote from the point of injection of the injector slurry into the fluid within the conduit. The adhesion promoter composition can be injected into the fluid at a location in the vicinity of the injection of the injector slurry into the fluid and simultaneously with the injector slurry.

Activation of the magneto-cryogenic valve attached to a conduit results in the heat
30 transfer system removing thermal energy from the conduit and its contents from the outside-in, and the introduction of negative thermal energy into the fluid within the conduit by introducing the injector slurry containing the magnetically susceptible particles into the fluid, resulting in the formation of a frozen plug of fluid. The transfer of thermal energy out

of the fluid, particularly to a cooled conduit in the vicinity of the heat transfer system using the magnetically susceptible particles, as can be achieved by the manipulation of the movement of the magnetically susceptible particles using the magnetic fields of the magnetic field generating device, can promote adhesion of the frozen fluid plug to the walls
5 of the conduit or valve chamber as well as increasing the rate of deposition of frozen fluid onto the conduit or valve chamber wall and subsequently onto layers of frozen fluid.

A magneto-cryogenic valve provided herein or a system containing the magneto-cryogenic valve can be attached to an intact conduit. In a method to reversibly prevent fluid flow through the conduit, the magneto-cryogenic valve is activated when necessary as an
10 emergency shut off mechanism of the conduit. For example, the magneto-cryogenic valve can be activated in case of failure or breach of the conduit. The magneto-cryogenic valve and systems described herein also can be used to provide a means of preventing fluid flow through a breached or broken conduit. In such instances, the method can include identifying a breach site in a conduit; deploying a magneto-cryogenic valve, attaching the magneto-
15 cryogenic valve to a point below (relative to the direction of flow through the conduit) the fracture, breach or break in an intact area of the conduit; and activating the magneto-cryogenic valve for a sufficient time to form a frozen plug of fluid that prevents flow of the fluid through the conduit. In the methods provided herein, the magneto-cryogenic valve can be maintained in active thermal exchange to maintain the frozen fluid plug firmly adhered to
20 the inner conduit wall until repairs can be made to the conduit. Then, when it is desirable to restore fluid flow through the conduit, the method includes as a step providing thermal energy to the conduit. At a certain temperature, the frozen fluid plug will begin to melt and detach from the inside surface of the conduit. Once the plug becomes detached from the inside surface of the conduit, fluid pressures within the conduit will dislodge the frozen plug,
25 restoring flow of the fluid through the conduit.

The magnetic fields of the magnetic field generating device can be used to restore flow of fluid in the conduit. For example, in some methods, the magnetic field generating device of the magneto-cryovalve can include a plurality of electromagnets in which oscillation of the B-field can be induced. By inducing an alternating magnetic field,
30 inductive heating can be produced. For example, some of the magnetically susceptible particles in the slurry can include a ferromagnetic coating. These ferromagnetic coated magnetically susceptible particles can be included in the injection slurry uniformly, so that they are distributed throughout the frozen plug of fluid. By alternating the magnetic field,

domains in the ferromagnetic coating on the particles can be excited. As the domains of the coatings realign with each oscillation, hysteresis losses in the coating cause inductive heating. The inductive heating can be proportional to flux density within the magnetically permeable coating. When the coated particles are distributed evenly throughout the frozen fluid plug, inductive heating via the alternating magnetic field will result in mostly uniform increase in temperature in the frozen core. At a certain temperature, the frozen fluid plug will begin to melt and detach from the inside surface of the conduit.

The ferromagnetic coated magnetically susceptible particles can be included in the injection slurry after formation of the frozen plug has begun so that the ferromagnetic coated magnetically susceptible particles are concentrated near the center of the plug. By alternating the magnetic field, domains in the ferromagnetic coating on the particles can be excited and hysteresis losses in the coating cause inductive heating. Because the coated particles are concentrated near the center of the frozen fluid plug, inductive heating via the alternating magnetic field will result in increase in the temperature of the center of the frozen core, producing a channel through which fluid can flow, restoring fluid flow. A benefit to this method of restoring flow is that the frozen fluid core can remain attached to the conduit wall, minimizing the possibility that it will be launched as a projectile upon melting and restoration of fluid flow.

In some methods, heating devices are included in the magneto-cryogenic valve and these heating devices are activated to provide thermal energy to melt the plug within the conduit. In some methods, the heating devices are used in conjunction with the magnetically produced inductive heating to provide thermal energy to melt the plug within the conduit.

In some methods, the heating devices can be arranged to provide thermal energy unilaterally or directionally to the conduit in the area of the plug of frozen fluid within the conduit. This directed application of thermal energy to the conduit in proximity to the frozen plug therein allows for directed melting of the plug, such as to form a channel through the plug through which liquid fluid can flow while the frozen plug remains adhered to the inner wall of the conduit. This prevents launching the frozen plug through the conduit, and permits controlled restoration of fluid flow through the conduit.

In some methods, a bypass circuit can be included in the system to eliminate pressure differential on either side of the frozen plug before thawing, and thereby minimizing or eliminating the possibility of launching the partially frozen plug through the

system. The bypass circuit would allow for the introduction of fluid to pressurize the low pressure side of the conduit prior to thawing the frozen fluid plug, thereby equalizing the pressure in the conduit on both sides of the frozen fluid plug prior to the plugs detachment from the inner wall of the conduit.

5 The methods provided herein produce a frozen plug of fluid, such as oil and/or gas, in a conduit, such as a well or pipeline, in order to stop the flow of fluid through the conduit. The plug serves to temporarily halt fluid flow, such as production in an oil well. In some instances, the oil well can be an above-ground pipeline or below-ground pipeline, while in other instances, the oil well can be off-shore, and can be a deep sea oil well. In the
10 systems and methods provided herein, the plug can be formed *in situ* and can be easily removed by allowing the plug to melt, passively or by controlled modulation of the temperature in the vicinity of the plug, such as by application of thermal energy via heating devices near the area of the conduit to which the heat transfer system is attached, or via magnetically produced inductive heating using the magnetic field generating device.

15 In some methods, the fluid flowing in the conduit contains hydrocarbons. It has been found that the plug formed in a hydrocarbon fluid by the extraction of thermal energy from the hydrocarbon-containing fluid can be amorphous due to the different precipitation/freezing rates of molecules of higher molecular weight compared to lower molecular weight materials. In such methods, injection of an adhesion promoter
20 composition, particularly an adhesion promoter composition containing at least one surfactant, into the fluid within the conduit prior to heat extraction and freezing of the hydrocarbon fluid results in a more homogeneous freeze of the fluid and promotes better adhesion of the frozen plug to the inside surface of the conduit.

 There are many times when the flow of a fluid through a conduit, such as oil through a
25 well, needs to be stopped. For example, the flow of oil in offshore oil well during storm conditions, or while performing maintenance on wellheads, or as an emergency shut off in case of a catastrophic event in which the conduit is damaged or ruptured such as during a seismic event, requires the use of a plug of some sort to stop the flow of fluid. The magneto-cryogenic valves and systems provided herein can be used to form a thermally reversible fluid
30 plug in wells on the surface or at any depth, such as at about 250 feet below the mud line (*i.e.*, 250 feet below the ocean floor) or in deep water applications, in which floating drill ships or semi-submersible rigs can operate in water depths of 6,000 feet or more. Accordingly, provided are methods of producing a frozen plug in a fluid, where the method includes

introduction of an injection slurry composition containing magnetically susceptible particles and optionally an adhesion promoter composition into the fluid within the conduit. A magnetic field generating device is activated thereby directing the particles at least in part to the inner wall of the conduit in the vicinity of the heat transfer device. The injection slurry
5 composition and optionally adhesion promoter composition can be injected into the fluid until the fluid becomes viscous or until the fluid resists flow or the fluid begins to freeze or the fluid becomes solid.

The methods provided herein can be used to temporarily isolate an oil well. The methods include activating a magneto-cryogenic valve attached to a portion of a producing
10 tubular in an oil well so that its heat transfer system is in thermal contact with at least one portion of the producing tubular, and activating a first injector to inject an injection slurry composition containing magnetically susceptible particle as provided herein into the fluid, such as oil in the producing tubular, and activating a second injector to inject an adhesion promoter composition as described herein.

15 **E. Examples**

The following examples are included for illustrative purposes only and are not intended to limit the scope of the embodiments provided herein.

EXAMPLE 1 - Motor Oil Only

The ability of a solidified oil plug to withstand pressure was tested. The strength of
20 the plug was analyzed using a Test Resources 310 Series Universal Testing Machine (UTM, Test Resources, Inc., Shakopee, MN). The plug was formed using a stainless steel 0.5 inch prototype magneto-cryogenic valve provided herein. The geometry of the valve chamber of the prototype magneto-cryogenic valve was essentially cylindrical having sloped end walls, as shown in **FIG. 28**. The width of the valve chamber was $3\times$ the diameter of the incoming
25 pipe (1.5 inches) and the length of the valve chamber was $3.33\times$ the width of the valve chamber (5 inches). Two 0.5 inch N50 NdFeB magnets with a maximum flux density of 13,200 Gs or 1.32T were positioned opposite from each other in the sloped wall of the second valve chamber segment, with like poles directed toward the valve chamber. The ends of the
30 magnets were flush with the outer wall of the valve chamber and did not penetrate into the valve chamber. The heat exchange unit included cryogenic cooling coils, a continuous cryogen compatible tubing forming the cryogenic cooling coils. The cryogenic cooling coils encircled the entire outer surface of the valve chamber (similar to that depicted in **FIG. 10**).

The valve chamber was cooled by discharging liquid nitrogen from a supply vessel through the cryogenic cooling coils, which removed thermal energy from the magneto-cryogenic valve. Temperature was monitored using a National Instruments NI 9211 thermocouple module (National Instruments, Austin, TX).

5 SAE 10W-30 motor oil (Valvoline) was used to represent light crude oil. The exit of the valve chamber of the prototype magneto-cryogenic valve was plugged using a thin cellophane barrier. The cellophane barrier was easily ruptured. Testing with the UTM applying force to this barrier resulted in no detection of load prior to rupture of the cellophane barrier. With an intact cellophane barrier in place, 154.8 g of motor oil was added
10 to the valve chamber. The cryogenic cooling coils of the heat exchange unit were charged with liquid nitrogen and liquid nitrogen flowed through the coils to cool the oil. The oil was taken from an initial temperature of 35°C (95°F) to -120°C. Solidification of the oil was confirmed at -120°C. After solidification of the oil, a 0.5 inch metal rod that snugly fit within the 0.5 inch inlet pipe was positioned in the inlet pipe, connected to the UTM, pushed
15 into the valve chamber by UTM, which accurately simulated application of a pressure load. The load was applied over 168.1 seconds, with load and position change data being digitally recorded by Test Resources Xyplot Software every 0.1 seconds. The maximum recorded load, which occurred at 168.1 seconds, was 9986.16 N. This corresponds to a maximum stress of 81,375 kPa (11,802 psi). At around 100 seconds, elastic deformation of the solid
20 was observed, as the slope of the load vs. displacement curve began to increase. At around 155 seconds, an internal failure within the solid occurred. After this initial failure, the load increased to the maximum supported force of the UTM, 9986.16 N. The data obtained demonstrated that a solidified oil plug can hold at least 12,000 psi of pressure.

EXAMPLE 2 - Ball Bearings Only

25 The ability of a plug of ball bearings to withstand pressure was tested. The same push-through experiment, described in Example 1, was performed using only ball bearings. The exit of the valve chamber of the prototype magneto-cryogenic valve was plugged using the thin cellophane barrier. 660 g of 4.5 mm diameter stainless steel ball bearings (McMaster-Carr, Santa Fe Springs, CA) were added to the valve chamber of the prototype
30 magneto-cryogenic valve. This experiment was performed at room temperature. The 0.5 inch metal rod connected to the UTM, was positioned in the inlet pipe and pushed into the valve chamber by UTM. The load applied by the metal rod onto the packed ball bearings as a function of time was measured. The maximum loading was quickly reached, after 35.3

seconds. At this loading, no failure was detected. The data showed that a packed bed of spheres at room temperature can hold at least 12,000 psi of pressure and exhibits a large increase in structural rigidity over the rigidity exhibited by the solidified oil plug.

EXAMPLE 3 - 0.5 mm × 5.0 mm Iron Rods with Motor Oil

5 The ability of a plug of frozen oil containing metal particles to withstand pressure was tested. The same push-through experiment, described in Example 1, was performed. The exit of the valve chamber of the prototype magneto-cryogenic valve was plugged using the thin cellophane barrier. 496.2 g of 0.5 mm × 5.0 mm ferromagnetic 302/304 stainless steel rods (Pellets LLC, North Tonawanda, NY) were added to the prototype magneto-cryogenic
10 valve chamber, and then 89.3 g of SAE 10W-30 motor oil (Valvoline) was added. The resulting mixture was cooled using the same heat exchanger setup described in Example 1 and the valve chamber was cooled using liquid nitrogen until a minimum of temperature of -130°C was reached, at which temperature the metal rod/oil composition was frozen solid. Following solidification of the rod/oil composite at this temperature, the same push-through
15 experiment as described in Example 1 was performed. The load applied by the metal rod onto the rod-and-oil composite as a function of time was recorded. The maximum loading was quickly reached after 39.5 seconds. The data showed that the frozen rod/oil composite can hold at least 12,000 psi of pressure, and has greatly enhanced heat transfer properties when compared to pure oil.

20 **EXAMPLE 4 – Heat Transfer Properties**

 Data for the rate of temperature change for the frozen plug of pure oil (Example 1) and the frozen plug of oil containing steel particles (Example 3) was collected. From the data, it was observed that the steel particles in the metal rod/oil composite plug increased the thermal transfer rate by approximately 70% when compared to a plug containing only frozen
25 oil.

 While various embodiments of the subject matter provided herein have been described, it should be understood that they have been presented by way of example only, and not limitation. Since modifications will be apparent to those of skill in this art, it is intended that this invention be limited only by the scope of the appended claims.

LIST OF FIGURE ELEMENTS

- 100 – magneto-cryogenic valve
- 110 – first injector device
- 111 – pipe connector to pump 112
- 5 112 – pump
- 113 – pipe connector to adhesion promoter supply module 200
- 120 – second injector device
- 121 – pipe to injector slurry supply module 300
- 125 – pipe to pressure regulator system 350
- 10 130 – heat transfer system
- 130a – interlocking first portion of heat transfer system
- 130b – interlocking second portion of heat transfer system
- 131 – inlet port
- 132 – inlet pressure regulator
- 15 133 – pipe to cryogen supply module
- 134 – connector
- 135 – outlet port
- 136 – outlet pressure regulator
- 137 – pressure relief valve
- 20 138 – vent
- 139 – space to accommodate support channel 160
- 140 – magnetic field generating device
- 145 – thermally conductive particles
- 146 – insulator
- 25 150 and 150' – connector
- 155 – cryogenic cooling coils
- 160 – support channel
- 160a – interlocking first portion of support channel
- 160b – interlocking second portion of support channel
- 30 170 – magnetically susceptible particles
- 170a, 170b, 170c, 170d, 170e – magnetically susceptible particles
- 200 – adhesion promoter composition supply module
- 300 – injector slurry supply module
- 350 – pressure regulator system
- 35 400 – cryogen supply module
- 500 – conduit
- 500' – conduit
- 550 – breach

- 600 – flange connector to incoming pipeline
- 601 – flange connector to outgoing pipeline
- 610 – flange bolt holes
- 620 – first valve chamber segment
- 5 621 – second valve chamber segment
- 625 – fold in valve chamber wall
- 640 – electromagnetic solenoid coil
- 650 – electromagnetic core
- 655 – electromagnetic core end
- 10 656 – electromagnetic core flange
- 660 – incoming pipeline-connecting conduit
- 661 – outgoing pipeline-connecting conduit
- 670 – incoming chamber-connecting conduit
- 671 – outgoing chamber-connecting conduit
- 15 680 – magnetic field generator port
- 685 – magnetic field generator end
- 700 – first cooling chamber segment
- 701 – second cooling chamber segment
- 705 – port to cooling chamber
- 20 706 – port to cooling chamber
- 710 – valve chamber bolt hole
- 715 – first valve chamber segment flange
- 716 – valve flange gasket
- 717 – second valve chamber segment flange
- 25 720 – valve chamber segment flange bolt hole
- 730 – instrument fitting
- 740 – threaded rod
- 741 – nut
- 750 – bolt hole
- 30 800 – entry to valve chamber
- 801 – exit from valve chamber
- 805 – flat valve chamber wall
- 810 – sloped valve chamber wall
- F↑ or F→ – direction of flow of fluid

Claims:

1. A magneto-cryogenic valve, comprising:

a connector for connecting the magneto-cryogenic valve to a conduit through which a fluid flows;

5 a heat transfer system;

a first injector device for injecting magnetically susceptible particles into the fluid;

a valve chamber; and

a magnetic field generating device,

wherein:

10 the valve chamber is connectable in fluid communication with the conduit so that the fluid of the conduit flows through the valve chamber;

the magnetic field generating device produces a magnetic field comprising field lines and at least a portion of the field lines penetrate through the fluid in the valve chamber and interact with the injected magnetically susceptible particles; and

15 the heat transfer system removes thermal energy from the valve chamber and the fluid therein.

2. The magneto-cryogenic valve of claim 1, further comprising a second injector device for injecting an adhesion promoter composition into the fluid.

20 3. The magneto-cryogenic valve of claim 1 or 2, wherein valve chamber comprises a portion of the conduit.

4. The magneto-cryogenic valve of any one of claims 1 to 3, wherein the heat transfer system is adapted to fit to a surface of at least a portion of a valve chamber with sufficient thermal intimacy that thermal energy can be transferred between the valve chamber and the heat transfer system.

25 5. The magneto-cryogenic valve of claim 2, further comprising a support channel to which the heat transfer system, the first injector device, the second injector device and the magnetic field generating device are attached.

30 6. The magneto-cryogenic valve of any one of claims 1 to 5, wherein the heat transfer system comprises a refrigeration system and the refrigeration system comprises a vapor compression system, a heat exchange unit, a cryogenic cooling system, or an electric thermal transfer device or a combination thereof.

7. The magneto-cryogenic valve of any one of claims 1 to 6, wherein the heat transfer system comprises cryogenic cooling coils.

8. The magneto-cryogenic valve of any one of claims 1 to 7, wherein the heat transfer system comprises a cooling chamber suitable to contain a cryogen.

5 9. The magneto-cryogenic valve of any one of claims 1 to 8, wherein the heat transfer system comprises a detachable housing comprising at least two side portions for enclosing a section of a conduit and two end portions for engaging in sealing relation with opposite ends of the side portions, the side and end portions defining a cooling chamber when assembled around the conduit, the cooling chamber confining a volume of a cryogen
10 at least a portion of which is in its liquid phase in intimate contact with the exterior surface of at least a portion of the section of conduit enclosed by the housing.

10. The magneto-cryogenic valve of claim 8 or 9, wherein the cooling chamber comprises particles, filings, turnings, shavings, pellets, threads or beads of a thermally conductive material.

15 11. The magneto-cryogenic valve of any one of claims 8 to 10, wherein the cooling chamber comprises:

an inlet port for admitting a cryogen into the cooling chamber; and

an outlet port for discharging the spent cryogen out of the cooling chamber.

20 12. The magneto-cryogenic valve of any one of claims 1 to 11, wherein the heat transfer system further comprises a conductor surface.

13. The magneto-cryogenic valve of claim 12, wherein the conductor surface comprises aluminum, beryllium, brass, cadmium, carbon steel, chrome, chrome nickel steel, cobalt, copper, gold, iridium, iron, lead, magnesium, molybdenum, nickel, platinum, silver, stainless steel, tin or zinc, or any combination or alloy thereof.

25 14. The magneto-cryogenic valve of any one of claims 1 to 13, wherein the heat exchange unit comprises baffles or fins.

15. The magneto-cryogenic valve of any one of claims 1 to 14, further comprising a heating device adjacent to the heat exchange unit.

30 16. The magneto-cryogenic valve of claim 15, wherein the heating device is selected from among Curie temperature heaters, conductor-in-conduit heaters, heater strips, ceramic heaters, resistance wire heaters and resistance ribbon heaters.

17. The magneto-cryogenic valve of any one of claims 1 to 16, wherein the magnetic field generating device comprises an electromagnet.

18. The magneto-cryogenic valve of any one of claims 1 to 17, wherein the magnetic field generating device comprises a permanent magnet.

5 19. The magneto-cryogenic valve of claim 18, wherein the permanent magnet comprises a ferrite material or a rare earth element.

20. The magneto-cryogenic valve of claim 18, wherein the permanent magnet is selected from among Nd-Fe-B type, Sm-Co type and Sm-N-Fe type rare earth permanent magnets.

10 21. The magneto-cryogenic valve of any one of claims 17 to 20, wherein the magnets are mounted on movable tracks.

22. The magneto-cryogenic valve of any one of claims 1 to 21, wherein the magnetic field generating device includes a plurality of electromagnets in which oscillation of the B-field can be induced.

15 23. The magneto-cryogenic valve of any one of claims 1 to 22, wherein a pole of a magnetic field generating device penetrates into the valve chamber.

24. The magneto-cryogenic valve of any one of claims 1 to 22, wherein no pole of a magnetic field generating device penetrates into the valve chamber.

20 25. The magneto-cryogenic valve of any one of claims 1 to 24, wherein an end of a magnetic field generating device is flush against a wall of the valve chamber.

26. The magneto-cryogenic valve of any one of claims 1 to 25, wherein the magnetic field of at least one magnetic field generating device directs the injected magnetically susceptible particles to the center of the valve chamber.

25 27. The magneto-cryogenic valve of any one of claims 1 to 26, wherein the magnetic field of at least one magnetic field generating device directs the injected magnetically susceptible particles to an end of the valve chamber.

28. The magneto-cryogenic valve of any one of claims 1 to 27, wherein the magnetic field of at least one magnetic field generating device directs the injected magnetically susceptible particles to a wall of the valve chamber.

30 29. The magneto-cryogenic valve of any one of claims 1 to 28, wherein the magnetic field generating device comprises an electromagnet or a permanent magnet having a magnetic flux density of about 0.1 Tesla to about 15 Tesla.

30. The magneto-cryogenic valve of any one of claims 1 to 29, wherein the magnetic field generating device produces an oscillating magnetic field.

31. The magneto-cryogenic valve of any one of claims 1 to 30, wherein the magnetic field generating devices are configured to provide a flux density of from about 0.5
5 Tesla to about 5 Tesla within the valve chamber.

32. The magneto-cryogenic valve of any one of claims 1 to 31, wherein the cooling chamber comprises a wall that is ridged, fluted, grooved, furrowed, crinkled, puckered, creased or wrinkled or any combination thereof.

33. The magneto-cryogenic valve of any one of claims 1 to 32, wherein the valve
10 chamber comprises at least one fold.

34. The magneto-cryogenic valve of any one of claims 1 to 33, wherein the valve chamber comprises:

one fold to create a kidney-shaped chamber; or
two folds to create a bi-lobed chamber; or
15 three folds to create a tri-lobed chamber; or
four folds to create a tetra-lobed chamber; or
five folds to create a penta-lobed chamber; or
six folds to create a hexa-lobed chamber; or
seven folds to create a hepta-lobed chamber; or
20 eight folds to create a octa-lobed chamber; or
nine folds to create a nona-lobed chamber; or
ten folds to create a deca-lobed chamber.

35. The magneto-cryogenic valve of any one of claims 1 to 34, wherein the valve chamber comprises symmetrical end walls.

25 36. The magneto-cryogenic valve of any one of claims 1 to 35, wherein the valve chamber comprises two 90° end walls.

37. The magneto-cryogenic valve of any one of claims 1 to 35, wherein the valve chamber comprises two sloped end walls.

30 38. The magneto-cryogenic valve of any one of claims 1 to 34, wherein the valve chamber comprises one 90° end wall and one sloped end wall.

39. The magneto-cryogenic valve of any one of claims 1 to 38, wherein the valve chamber has a width that is from about $1\times$ to about $10\times$ the inner diameter of the conduit to which the magneto-cryogenic valve is attached.

5 40. The magneto-cryogenic valve of any one of claims 1 to 39, wherein the valve chamber has a length that is from about $1.5\times$ to about $10\times$ the inner diameter of the conduit to which the magneto-cryogenic valve is attached.

41. The magneto-cryogenic valve of any one of claims 1 to 40, wherein the valve chamber comprises at least one wall that is ridged, fluted, grooved, furrowed, crinkled, puckered, creased or wrinkled or any combination thereof.

10 42. The magneto-cryogenic valve of any one of claims 1 to 41, wherein the valve chamber comprises at least one wall that contains projections or indentations or a combination thereof.

43. The magneto-cryogenic valve of any one of claims 1 to 42, wherein the first and second injectors comprise an isolation mechanism for controlling the flow of material
15 through the injectors.

44. The magneto-cryogenic valve of any one of claims 1 to 43 wherein the first and second injectors comprise an activatable flow modulating valve to adjust the flow of material through the injector.

20 45. The magneto-cryogenic valve of any one of claims 1 to 44, wherein the first injector or second injector or both comprise one or more or a combination of a flow rate meter, an emergency shut-off valve, an over-pressure valve, a diverter valve, a heating unit or a thermal monitoring device.

46. The magneto-cryogenic valve of any one of claims 1 to 45, wherein the extraction of thermal energy by the heat exchange unit results in the formation of a frozen
25 plug within the valve chamber that can stop the flow of fluid through the conduit.

47. A system for extracting thermal energy from a conduit containing a fluid, comprising:

a magneto-cryogenic valve of any one of claims 1 to 46; and
an injector slurry supply module.

30 48. The system of claim 47, further comprising an adhesion promoter composition supply module.

49. The system of claim 48, further comprising a pressure regulator system connected to the injector slurry supply module.

50. The system of any one of claims 47 to 49, further comprising a cryogen supply module.

5 51. The system of any one of claims 47 to 50, further comprising a pump in fluid communication with the adhesion promoter composition supply module.

52. The system of any one of claims 47 to 51, further comprising one or more or a combination of flow control valves, diverter valves, pressure relief valves, pressure monitoring devices, temperature monitoring devices, or flow rate measuring devices.

10 53. The system of any one of claims 47 to 52, further comprising a computer control module.

54. The system of any one of claims 47 to 53, wherein the injector slurry supply module is in fluid communication with the second injector of the magneto-cryogenic valve and provides an injector slurry composition to the second injector.

15 55. The system of claim 54, wherein the injector slurry comprises magnetically susceptible particles.

56. The system of claim 55, wherein the injector slurry comprises magnetically susceptible particles that are paramagnetic or diamagnetic or ferromagnetic or any combination thereof.

20 57. The system of claim 55 or 56, wherein the injector slurry comprises magnetically susceptible particles containing cobalt, Co-Zr alloys, Co-Nb alloys, dysprosium, Fe-Si alloys, gadolinium, iron, mu metal (nickel iron alloy), nickel, permalloys (iron-nickel alloys), rare earth-transition metal alloys, spinel ferrites or supermalloy or any combination or alloy thereof.

25 58. The system of any one of claims 55 to 57, wherein the injector slurry comprises magnetically susceptible particles containing a Gd-Co or Fe-Tb alloy.

59. The system of any one of claims 55 to 58, wherein the injector slurry comprises magnetically susceptible particles containing cobalt, iron, nickel, magnetite (Fe_3O_4) or maghemite (Fe_2O_3) or combinations thereof.

30 60. The system of any one of claims 55 to 59, wherein the injector slurry comprises magnetically susceptible particles having a thermal conductivity greater than $0.2 \text{ W}/(\text{m}\cdot\text{K})$, or greater than $0.5 \text{ W}/(\text{m}\cdot\text{K})$, or greater than $0.75 \text{ W}/(\text{m}\cdot\text{K})$, or greater than $1 \text{ W}/(\text{m}\cdot\text{K})$, or

greater than 5 W/(m·K), or greater than 10 W/(m·K), or greater than 20 W/(m·K), or greater than 30 W/(m·K), or greater than 40 W/(m·K), or greater than 50 W/(m·K) or greater than 100 W/(m·K).

61. The system of any one of claims 55 to 60, wherein the injector slurry comprises
5 magnetically susceptible particles having a shape selected from among cubes, flakes, granules, cylinders, rings, rods, needles, prisms, disks, fibers, pyramids, spheres, spheroids, prolate spheroids, oblate spheroids, ellipsoids, ovoids, hexahedrons, hexagonal prisms, tetrahedrons, octahedrons, truncated octahedrons, dodecahedrons, triangular prisms or random non-geometric shapes or any combinations of these shapes.

10 62. The system of any one of claims 55 to 61, wherein the injector slurry comprises magnetically susceptible particles that are solid.

63. The system of any one of claims 55 to 62, wherein the injector slurry comprises magnetically susceptible particles that are hollow.

64. The system of any one of claims 55 to 63, wherein the injector slurry comprises
15 magnetically susceptible particles that include a partial or complete coating comprising a thermally conductive material or an oxide or a combination thereof.

65. The system of claim 64, wherein the thermally conductive material comprises
beryllium, brass, cadmium, carbon steel, chrome nickel steel, cobalt, copper, gold, iridium, iron, lead, magnesium, molybdenum, nickel, platinum, silver, stainless steel, tin or zinc, or
20 any combination or alloy thereof.

66. The system of claim 65, wherein the oxide comprises an oxide of alumina, aluminum, barium, beryllium, bismuth, chromium, cobalt, copper, gadolinium iridium, iron, magnesium, manganese, molybdenum, nickel, niobium, silica, silicon, silver, tantalum, thorium, tin, titanium, tungsten, vanadium, yttrium, zinc, zirconia or zirconium or
25 combinations thereof.

67. The system of any one of claims 55 to 66, wherein the injector slurry comprises magnetically susceptible particles that include a partial or complete coating comprising a corrosion-resistant material.

68. The system of claim 67, wherein the corrosion-resistant material comprises zinc,
30 magnesium and cadmium or an alloy of any two or more of these.

69. The system of any one of claims 55 to 68, wherein the injector slurry comprises magnetically susceptible particles include a partial or complete ferromagnetic coating.

70. The system of any one of claims 55 to 69, wherein the injector slurry comprises magnetically susceptible particles having a uniform surface geometry.

71. The system of any one of claims 55 to 70, wherein the injector slurry comprises magnetically susceptible particles of a particle size from about 1 nm to about 20 cm.

5 72. The system of any one of claims 55 to 71, wherein the injector slurry comprises magnetically susceptible particles of a particle size from about 1 nm to about 100 μm .

73. The system of any one of claims 55 to 71, wherein the injector slurry comprises magnetically susceptible particles of a particle size greater than 100 μm and less than 5 cm.

10 74. The system of any one of claims 55 to 71, wherein the injector slurry comprises magnetically susceptible particles of a particle size between about 1000 μm and about 1 cm.

15 75. The system of any one of claims 55 to 71, wherein the injector slurry comprises magnetically susceptible particles of a bimodal particle size distribution, wherein one mode of the distribution has an average particle size between about 1000 μm and about 10 cm and the other mode of the distribution has an average particle size between about 1 nm and 100 μm .

76. The system of any one of claims 55 to 75, wherein the amount of magnetically susceptible particles in the injection slurry composition is from 0.01% to 95% based on the weight of the injection slurry composition.

20 77. The system of any one of claims 55 to 75, wherein the amount of magnetically susceptible particles in the injection slurry composition is greater than 95% based on the weight of the injection slurry composition.

78. The system of any one of claims 54 to 77, wherein the injector slurry composition comprises a carrier.

25 79. The system of claim 78, wherein the carrier comprises a cryogen or a solvent or a combination thereof.

80. The system of claim 79 wherein the cryogen comprises liquid nitrogen, liquid oxygen, liquid helium, liquid neon, liquid methane, liquid natural gas, liquid argon, liquid nitrous oxide, or liquid carbon dioxide or combinations thereof.

30 81. The system of claim 79 or 80, wherein the amount of cryogen the injector slurry composition is from 1% to 99% based on the weight of the injector slurry composition.

82. The system of claim 79, wherein the solvent comprises benzene, ethyl acetate, propyl acetate, butyl acetate, cyclohexanol, ether, methylethyl ketone, petroleum ether, *n*-

hexane, heptane, cyclohexane, naphtha, isopropyl biphenyl, terpene, toluene, xylene, hexamethyl disiloxane, octamethyl cyclotetrasiloxane, diphenyl tetramethyl disiloxane or trimethylsiloxy end-blocked polydimethylsiloxane fluids or a combination thereof.

83. The system of claim 79, wherein the solvent comprises acetaldehyde, acetone,
5 acetonitrile, acrolein, benzene, benzonitrile, bromo-benzene, butanol, butyl acetate, *n*-butyl amine, *t*-butyl amine, butyl bromide, carbitol acetate, carbon disulfide, carbon tetrachloride, chlorobenzene, chloroform, cyclohexane, cyclohexanone, cyclopentane, *m*-dichlorobenzene, *o*-dichloro-benzene, diethyl carbitol, diethyl ether, dioxane, ethanol, ethyl acetate, ethyl bromide, ethylene glycol, ethyl methyl ketone, glycerin, heptane, heptanone, hexane,
10 hexanol, 1,5-hexadiene, isoamyl acetate, isooctane, isopentane, isopropanol, methanol, methyl cyclohexane, nitroethane, nitromethane, *n*-octane, octanol, *i*-pentane, *m*-pentane, propanol, propylene glycol, pyridine, toluene, thiophene, trichloroethylene, *m*-xylene or *p*-xylene or any combination thereof.

84. The system of any one of claims 79 to 83, wherein the amount of solvent in the
15 injector slurry composition is from about 0.05% to 75% based on the weight of the injector slurry composition.

85. The system of any one of claims 47 to 84, wherein the adhesion promoter supply module is in fluid communication with the first injector of the magneto-cryogenic valve and provides an adhesion promoter composition to the second injector.

20 86. The system of claim 85, wherein the adhesion promoter composition comprises a surface tension reducer.

87. The system of claim 86, wherein the a surface tension reducer comprises a surfactant, a sulfonic acid, an alkali metal salt of a sulfonic acid, an alcohol, an amine, an esters, a siloxane, or a mono and dialkylated oxazoline where the alkyl chain length is
25 between about 2 to about 30 carbons or any combination thereof.

88. The system of claim 86 or 87, wherein the a surface tension reducer comprises an anionic surfactant, a cationic surfactant, a nonionic surfactant, a zwitterionic surfactant, a fluorosurfactant, a silicone surfactant or an amphoteric agent or any combination thereof.

89. The system of claim 88, wherein the surfactant is an anionic surfactant selected
30 from among alkali metal alkyl sulfates, alkyl or alkylaryl sulfonates, linear or branched alkyl ether sulfates and sulfonates, alcohol polypropoxylated and/or polyethoxylated sulfates,

alkyl or alkylaryl disulfonates, alkyl disulfates, alkyl sulphosuccinates, alkyl ether sulfates, linear and branched ether sulfates and mixtures thereof.

90. The system of claim 88, wherein the surfactant is a cationic surfactant selected from among arginine methyl esters, alkanolamines and alkylenediamides and mixtures thereof.

91. The system of claim 88, wherein the surfactant is an amphoteric agent selected from among betaines, sulphobetaines, imidazoline betaines and alkyl amido propyl betaines.

92. The system of claim 88, wherein the surfactant is a nonionic surfactant selected from among condensation products of ethylene oxide with aliphatic alcohols having from 8 to 22 carbon atoms in either straight or branched chain configuration, condensation products of ethylene oxide with nonyl phenol, phenol, butyl phenol, di-nonyl phenol, octyl phenol or other phenols, sorbitan esters and amine oxides, ethoxylated C₁₀-C₂₀ alcohols, fatty acids, fatty amines or glyceryl esters, alkyl polyglycosides, methyl glucoside esters, and blends of such nonionic surfactants.

93. The system of any one of claims 86 to 92, wherein the surface tension reducer comprises a polyol or a derivative of a polyol.

94. The system of any one of claims 86 to 93, wherein the adhesion promoter composition comprises an amount of surface tension reducer from about 0.01% to about 50% based on the weight of the adhesion promoter composition.

95. The system of any one of claims 85 to 94, wherein the adhesion promoter composition comprises a solvent.

96. The system of claim 95, wherein the solvent comprises acetaldehyde, acetone, acetonitrile, acrolein, benzene, benzonitrile, bromo-benzene, butanol, butyl acetate, *n*-butyl amine, *t*-butyl amine, butyl bromide, carbitol acetate, carbon disulfide, carbon tetrachloride, chlorobenzene, chloroform, cyclohexane, cyclohexanone, cyclopentane, *m*-dichlorobenzene, *o*-dichloro-benzene, diethyl carbitol, diethyl ether, dioxane, ethanol, ethyl acetate, ethyl bromide, ethylene glycol, ethyl methyl ketone, glycerin, heptane, heptanone, hexane, hexanol, 1,5-hexadiene, isoamyl acetate, isooctane, isopentane, isopropanol, methanol, methyl cyclohexane, nitroethane, nitromethane, *n*-octane, octanol, *i*-pentane, *m*-pentane, propanol, propylene glycol, pyridine, toluene, thiophene, trichloroethylene, water, *m*-xylene or *p*-xylene or any combination thereof.

97. The system of any one of claims 85 to 96, wherein the adhesion promoter composition comprises an amount of solvent from about 0.05% to about 85% based on the weight of the adhesion promoter composition.

5 98. The system of any one of claims 50 to 97, wherein the cryogen supply module is in fluid communication with the heat transfer system of the magneto-cryogenic valve and provides a cryogen to the heat transfer system.

99. The system of claim 98, wherein the cryogen comprises liquid carbon dioxide, liquid ammonia, liquified chlorofluorohydrocarbons, liquid nitrogen, liquid oxygen, liquid neon, liquid argon, liquid nitrous oxide, hydrofluoroethane, pentafluoropropane, trichloro-
10 monofluoromethane or dichlorodifluoromethane, or a mixture or any combination thereof.

100. The system of any one of claims 50 to 99, wherein the cryogen supply module further comprises a non-thermally conducting surface in contact with the environment to thermally isolate the cryogen supply module from the environment.

101. The system of any one of claims 50 to 100, wherein the cryogen supply
15 module further comprises a thermal monitoring device for monitoring the temperature of the cryogen or the pipes carrying the cryogen or a combination thereof.

102. The system of any one of claims 50 to 101, wherein the cryogen supply module further comprises a flow rate meter for determining the flow rate of cryogen from the module.

20 103. The system of claim 53, wherein the computer module comprises a computer in communication with and/or in control of any part of the magneto-cryogenic valve or element of the system containing the magneto-cryogenic valve.

104. The system of claim 103, wherein the computer module allows for automation of the magnetic field generating device.

25 105. The system of claim 103 or 104, wherein the computer module allows for automation of the cryogen supply module.

106. The system of any one of claims 103 to 105, wherein the computer module allows for automation of the injector slurry module.

30 107. The system of any one of claims 103 to 106, wherein the computer module allows for automation of the adhesion promoter composition supply module.

108. The system of any one of claims 103 to 107, wherein the computer module comprises a non-transitory computer-readable storage medium having a computer-readable program embodied therein for directing operation of the magneto-cryogenic valve.

5 109. The system of any one of claims 47 to 108, further comprising a pump in fluid communication with the cryogen supply module and the heat transfer system for pumping the cryogen to the heat transfer system.

110. The system of any one of claims 50 to 109, wherein the cryogen supply module comprises one or more of a flow rate meter, a flow-control metering valve, an isolation valve, an emergency shut-off valve, an over-pressure valve, a diverter valve, a heating unit, or a thermal monitoring device or any combination thereof.

111. A method for temporarily preventing the flow of fluid in a conduit, comprising:
activating a magneto-cryogenic valve of any one of claims 1 to 46 or a system of any one of claims 47 to 110 attached to the conduit, wherein the heat transfer system of the magneto-cryogenic valve removes sufficient thermal energy from the fluid to cause at least a portion of the fluid in the valve chamber of the magneto-cryogenic valve to freeze to form a reversible plug that prevents the fluid from flowing through the conduit.

112. The method of claim 111, wherein the frozen plug transfers the upstream pressure load from the fluid to the walls of the valve chamber.

113. The method of claim 111 or 112, wherein activating the magneto-cryogenic valve comprises charging the heat transfer system so that it is able to extract thermal energy from at least a portion of the conduit to which the heat transfer system is attached or from a fluid contained therein.

114. The method of claim 113, wherein charging the heat transfer system comprises activating the cryogen supply module to provide cryogen to the heat transfer system.

25 115. The method of any one of claims 113 to 114, wherein activating the magneto-cryogenic valve further comprises activating the pump attached to the adhesion promoter composition supply module to cause adhesion promoter to be injected into the fluid within the conduit via the first injector of the magneto-cryogenic valve.

116. The method of any one of claims 113 to 115, wherein activating the magneto-cryogenic valve further comprises activating the pressure regulator system attached to the injector slurry supply module to cause an injector slurry composition comprising

magnetically susceptible particles to be injected into the fluid within the conduit via the second injector of the magneto-cryogenic valve.

117. The method of any one of claims 111 to 116, wherein activating the magneto-cryogenic valve further comprises activating the magnetic field generating device to
5 produce magnetic fields.

118. The method of claim 117, wherein the magnetic fields of the magnetic field generating device interact with the magnetically susceptible particles of the injection slurry.

119. The method of claim 118, wherein the magnetic field of the magnetic field generating device positions at least a portion of the magnetically susceptible particles near
10 the inner wall of the chamber and the positioning of the magnetically susceptible particles near the inner wall of the conduit or valve chamber results in the freezing of at least some portion of the fluid onto the wall of the conduit or valve chamber, or onto previously frozen fluid or magnetically susceptible particles attached to the inner wall of the conduit or valve chamber.

120. The method of any one of claims 111 to 119, wherein the first injector of the magneto-cryogenic valve is positioned so that the injection of the adhesion promoter composition into the fluid within the conduit occurs before the second injector introduces
15 the injection slurry composition into the fluid within the conduit.

121. The method of any one of claim 111 to 120, wherein the heat transfer system or the second injector injecting the injection slurry composition or both is/are activated for a
20 sufficient amount of time to form a frozen plug of fluid that prevents flow of the fluid through the conduit.

122. The method of any one of claims 111 to 121, further comprising as a step increasing the temperature in the vicinity of the attachment of the heat transfer system to
25 donate thermal energy to the conduit, thereby at least partially melting the frozen plug and restoring flow of the fluid through the conduit.

123. The method of claim 122, wherein the temperature is increased by oscillating a magnetic field of a magnetic field generating device.

124. The method of claim 122, wherein the temperature is increased by activating a
30 heating device.

125. The method of claim 124, wherein the heating device is selected from among Curie temperature heaters, conductor-in-conduit heaters, heater strips, ceramic heaters, resistance wire heaters and resistance ribbon heaters.

5 126. The method of any one of claims 111 to 125, further comprising as a step inducing an alternating magnetic field using the magnetic field generating device to produce inductive heating of the magnetically susceptible particles in the frozen plug, thereby at least partially melting the frozen plug and restoring flow of the fluid through the conduit.

127. The method of claim 126, wherein the injection slurry composition comprises magnetically susceptible particles comprising a ferromagnetic coating.

10 128. The method of claim 127, where the injection slurry composition comprising magnetically susceptible particles that include a ferromagnetic coating are injected into the fluid of the conduit after at least a portion of the fluid has begun to form on the walls of the conduit or valve chamber, thereby positioning the ferromagnetic coated magnetically susceptible particles in the interior of the frozen plug of fluid.

15 129. The method of any one of claims 111 to 128, wherein the fluid within the conduit comprises a hydrocarbon gas or hydrocarbon fluid or combination thereof.

130. The method of any one of claims 111 to 129, wherein the fluid comprises petroleum and the conduit comprises a pipeline or an oil well.

20 131. The method of any one of claims 116 to 130, wherein the magnetically susceptible particles cause localized modulation in temperature and viscosity of the fluid within the conduit.

132. The method of any one of claims 116 to 131, wherein the injector slurry composition comprise magnetically susceptible particles are hollow.

25 133. The method of any one of claims 111 to 131, wherein the injector slurry composition comprises magnetically susceptible particles of a particle size from about 1 nm to about 20 cm.

134. The method of any one of claims 111 to 132, wherein the injector slurry composition comprises magnetically susceptible particles of a particle size from about 1 nm to about 100 μm .

30 135. The method of any one of claims 111 to 132, wherein the injector slurry composition comprises magnetically susceptible particles of a particle size greater than 100 μm and less than 5 cm.

136. The method of any one of claims 83 to 132, wherein the injector slurry composition comprises magnetically susceptible particles of a particle size between about 1000 μm and about 1 cm .

137. The method of any one of claims 83 to 132, wherein the injector slurry composition comprises magnetically susceptible particles of the injector slurry of a bimodal particle size distribution, wherein one mode of the distribution has an average particle size between about 1000 μm and about 17 cm and the other mode of the distribution has an average particle size between about 1 nm and 100 μm .

138. The method of any one of claims 116 to 137, wherein the step of injecting an injector slurry comprises injecting a plurality of different injector slurries each containing magnetically susceptible particles having a different average particle size.

139. The method of claim 138, wherein at least three different injector slurries are injected in any order into the fluid, wherein:

a first slurry comprises magnetically susceptible particles of an average particle size of about 50% of the diameter of the conduit;

a second slurry comprises magnetically susceptible particles of an average particle size of about 50% or less of the diameter of the magnetically susceptible particles of the first slurry; and

a third slurry comprises magnetically susceptible particles of an average particle size of about 50% or less of the diameter of the magnetically susceptible particles of the second slurry.

140. The method of any one of claims 111 to 139, wherein the volume fraction of magnetically susceptible particles injected into the valve chamber is greater than 90%.

141. The method of any one of claims 111 to 140, wherein the magnetically susceptible particles have a shape selected from among cubes, flakes, granules, cylinders, rings, rods, needles, prisms, disks, fibers, pyramids, spheres, spheroids, prolate spheroids, oblate spheroids, ellipsoids, ovoids, hexahedrons, hexagonal prisms, tetrahedrons, octahedrons, truncated octahedrons, dodecahedrons, triangular prisms or random non-geometric shapes or any combinations of these shapes.

142. The method of any one of claims 111 to 141, wherein prior to injection, the magnetically susceptible particles are cooled to a temperature below the freezing temperature of the fluid within the conduit.

143. The method of any one of claims 111 to 142, wherein the heat transfer system includes a refrigeration system that contains a compressor, a condenser and a heat exchange unit.

5 144. The method of claim 143, wherein the compressor comprises a reciprocating compressor, a rotary compressor, a screw compressor, a scroll compressor or a combination of any one of these compressors.

10 145. The method of any one of claims 111 to 144, wherein the heat transfer system comprises a refrigeration system that comprises a vapor compression refrigeration system, a heat exchange unit, a magnetic refrigeration unit or a cryogenic cooling system or a combination thereof.

146. The method of any one of claims 111 to 145, wherein the magnetic field generating device produces an oscillating magnetic field to optimize granular bed formation of magnetically susceptible particles within the frozen plug.

15 147. The method of any one of claims 111 to 146, further comprising turning off or disengaging the magnetic field to promote failure of the plug.

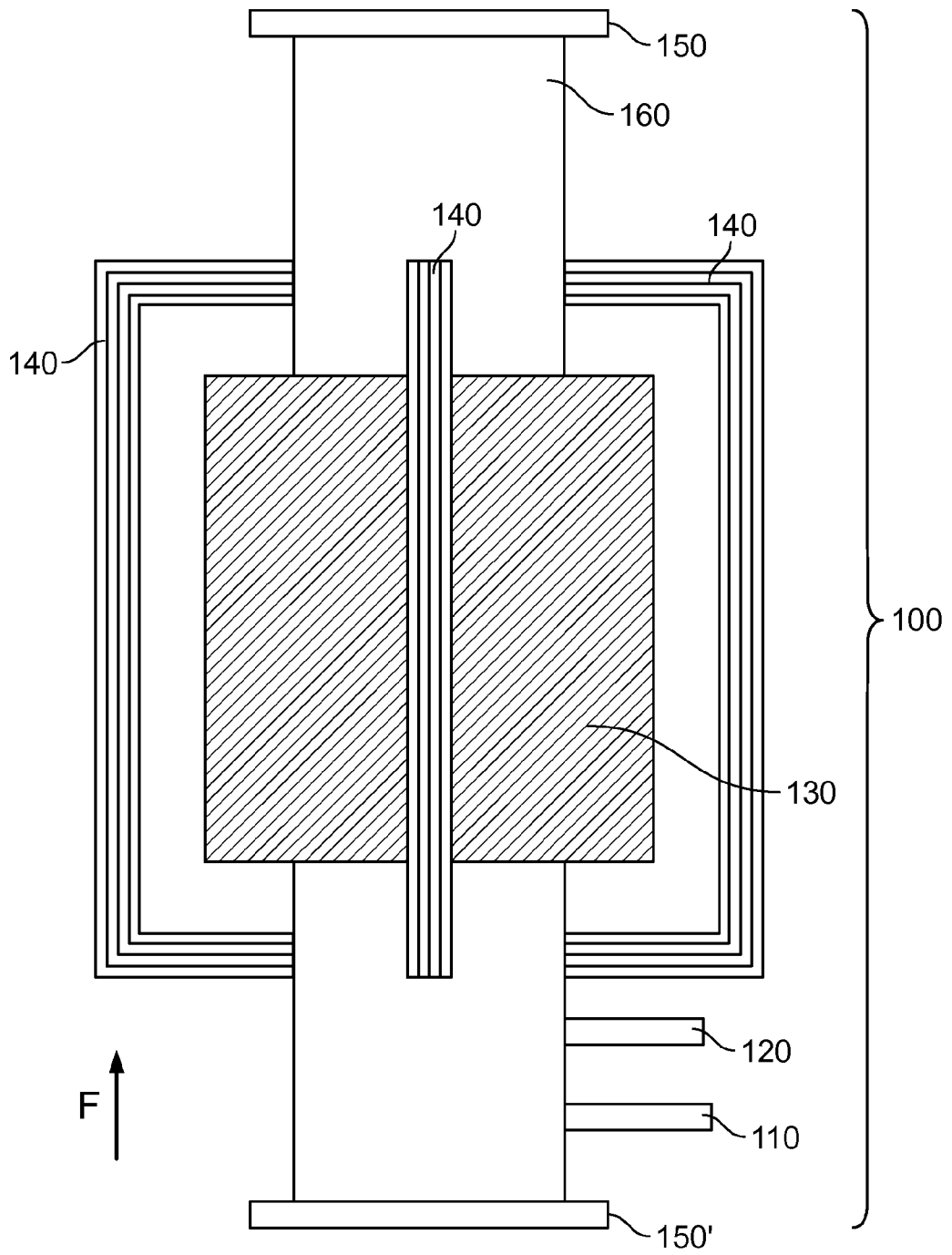

FIG. 1

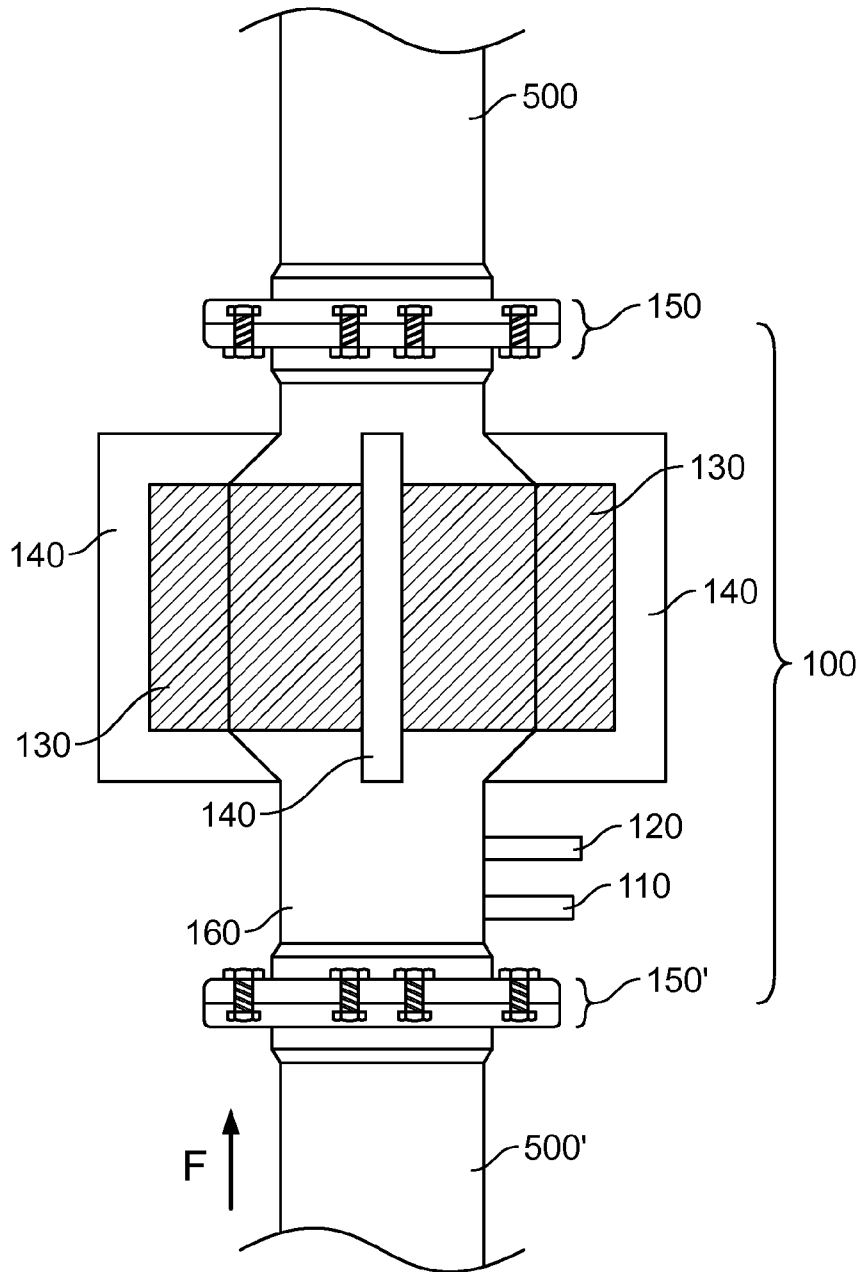

FIG. 2

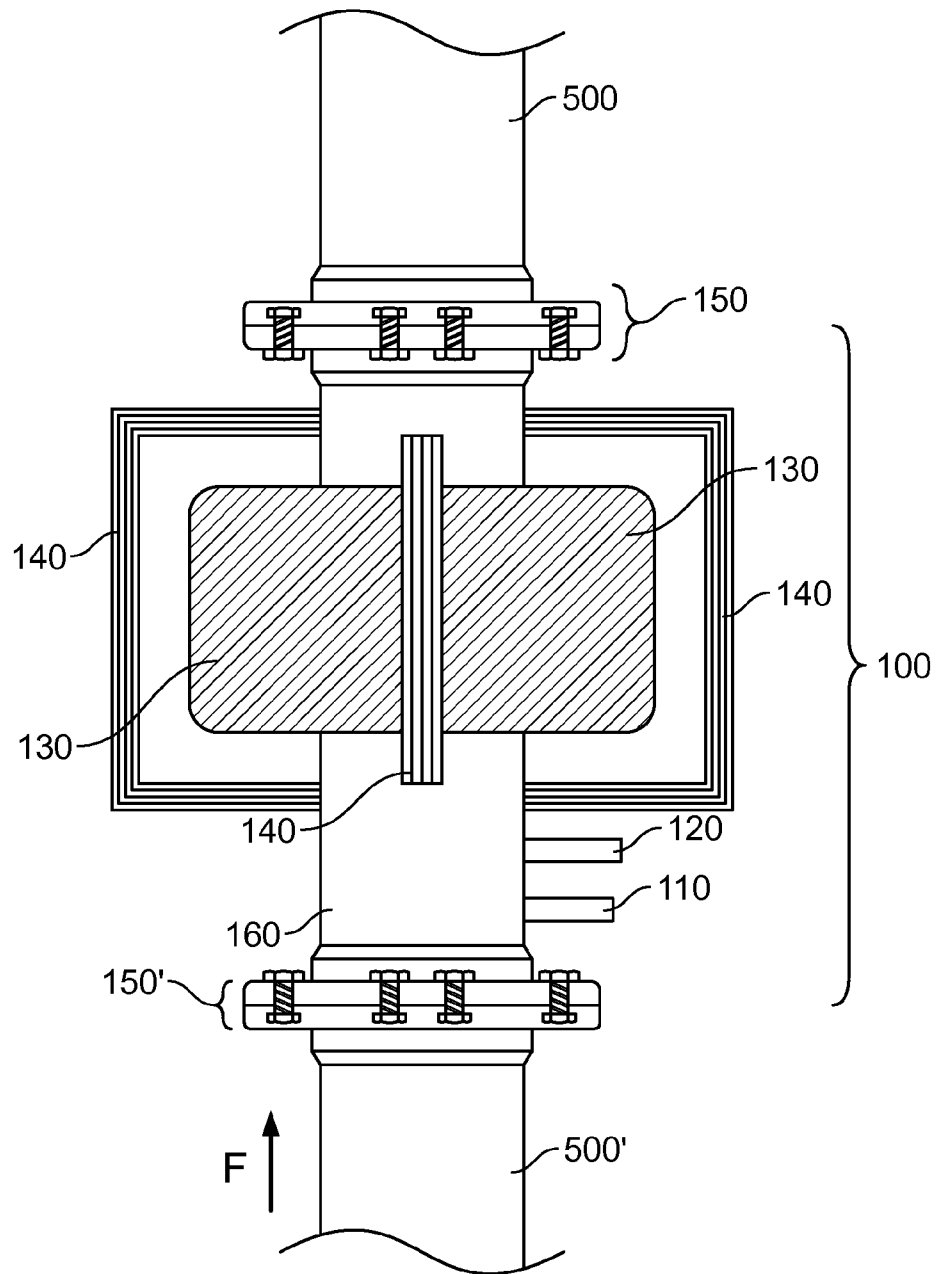

FIG. 3

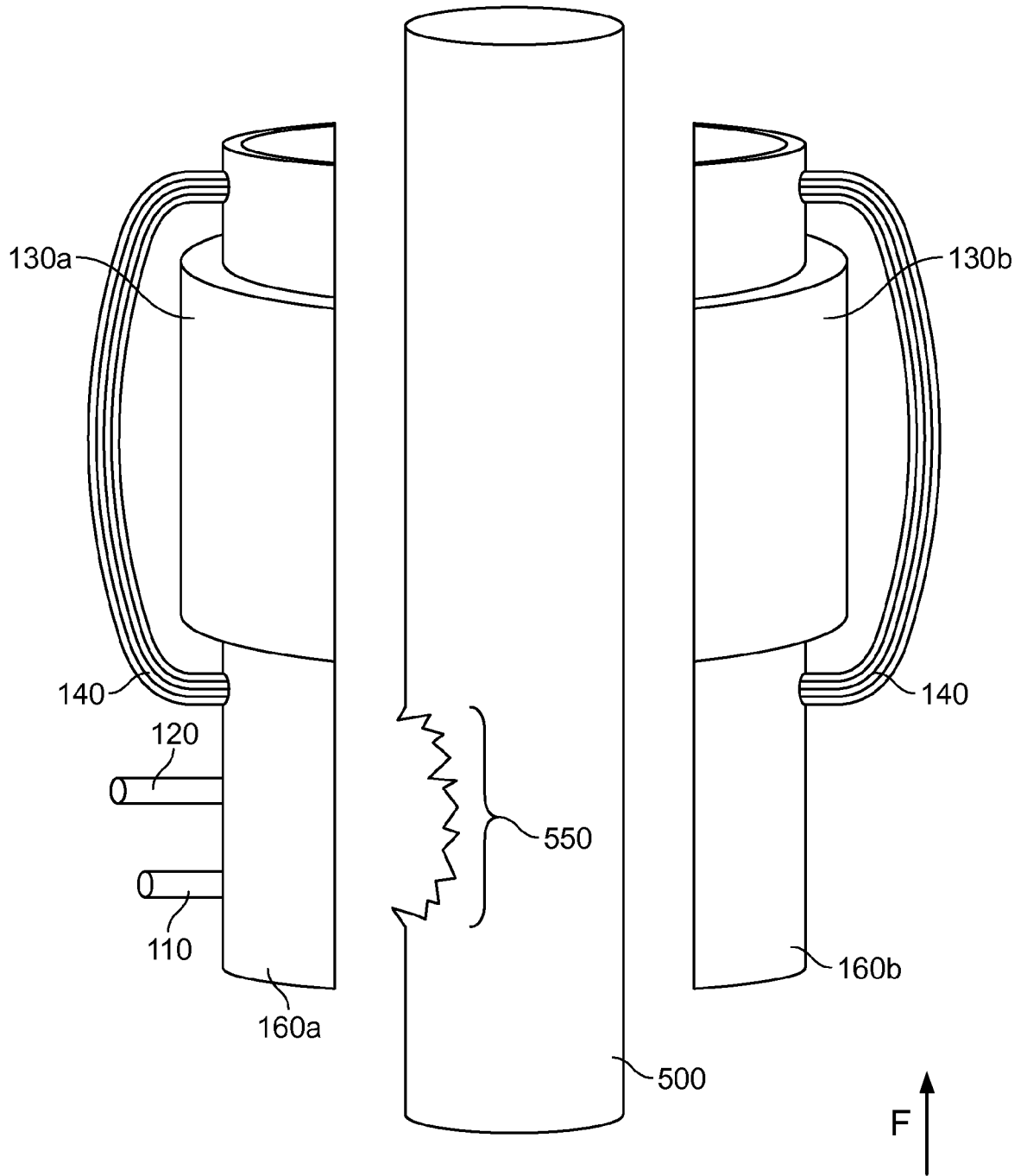

FIG. 4

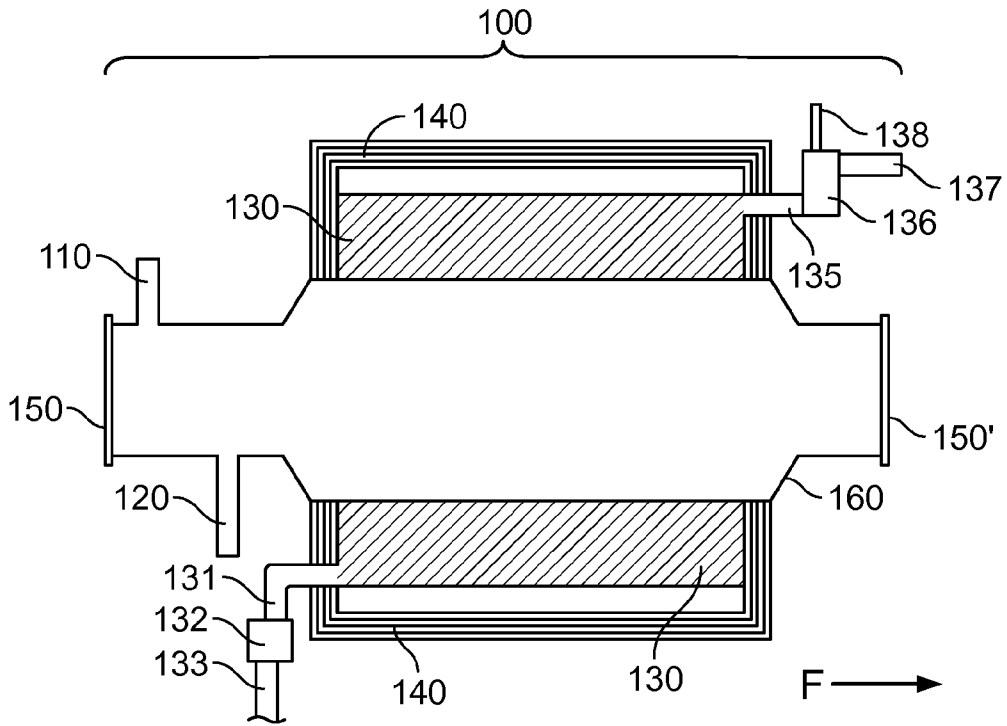

FIG. 5

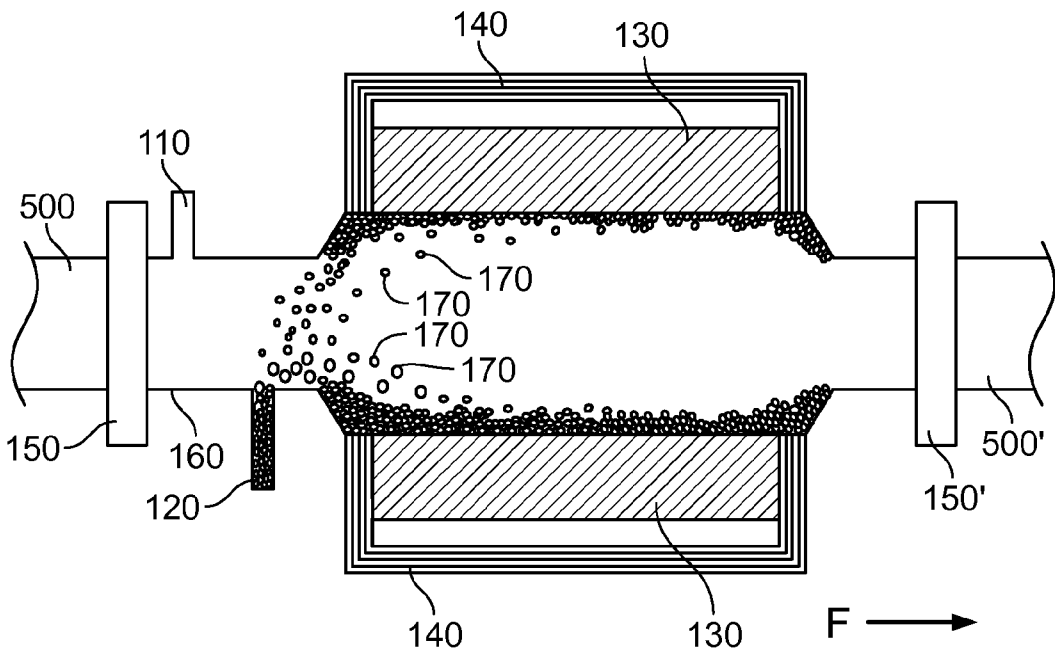

FIG. 6A

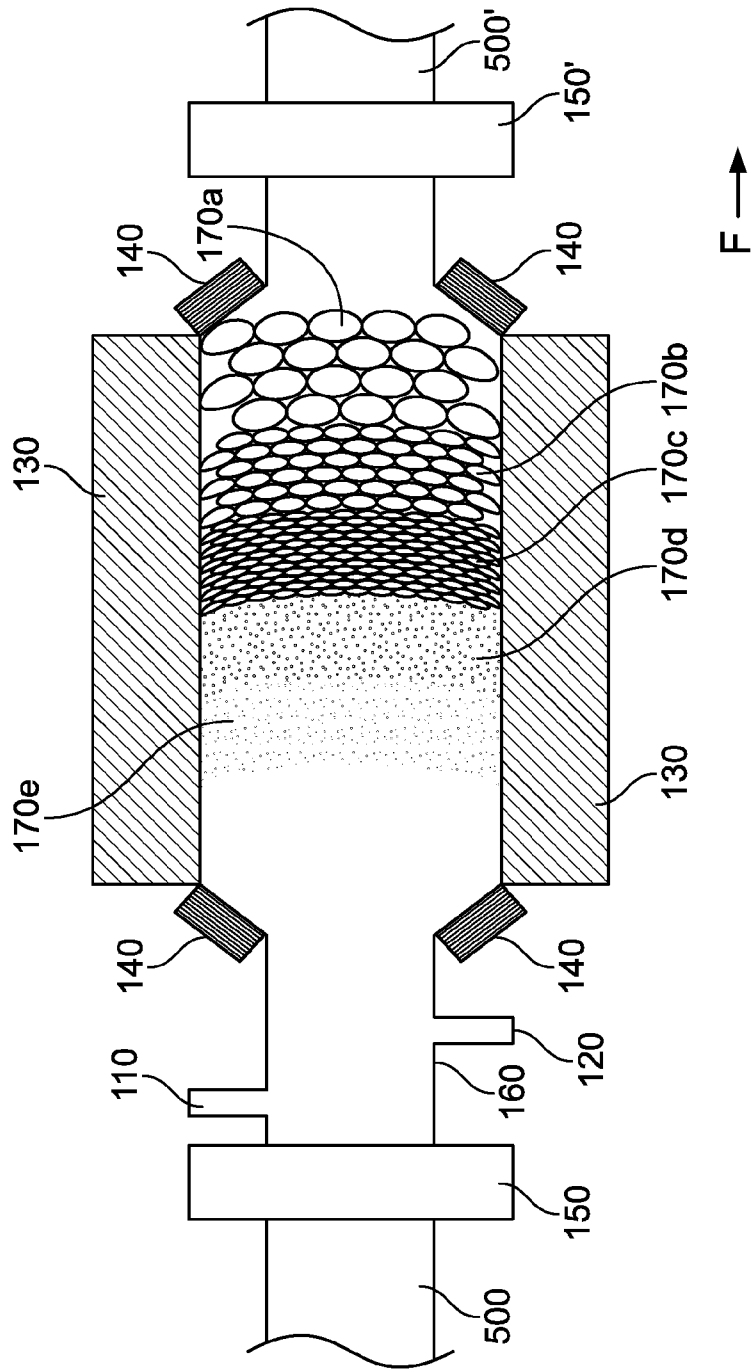

FIG. 6B

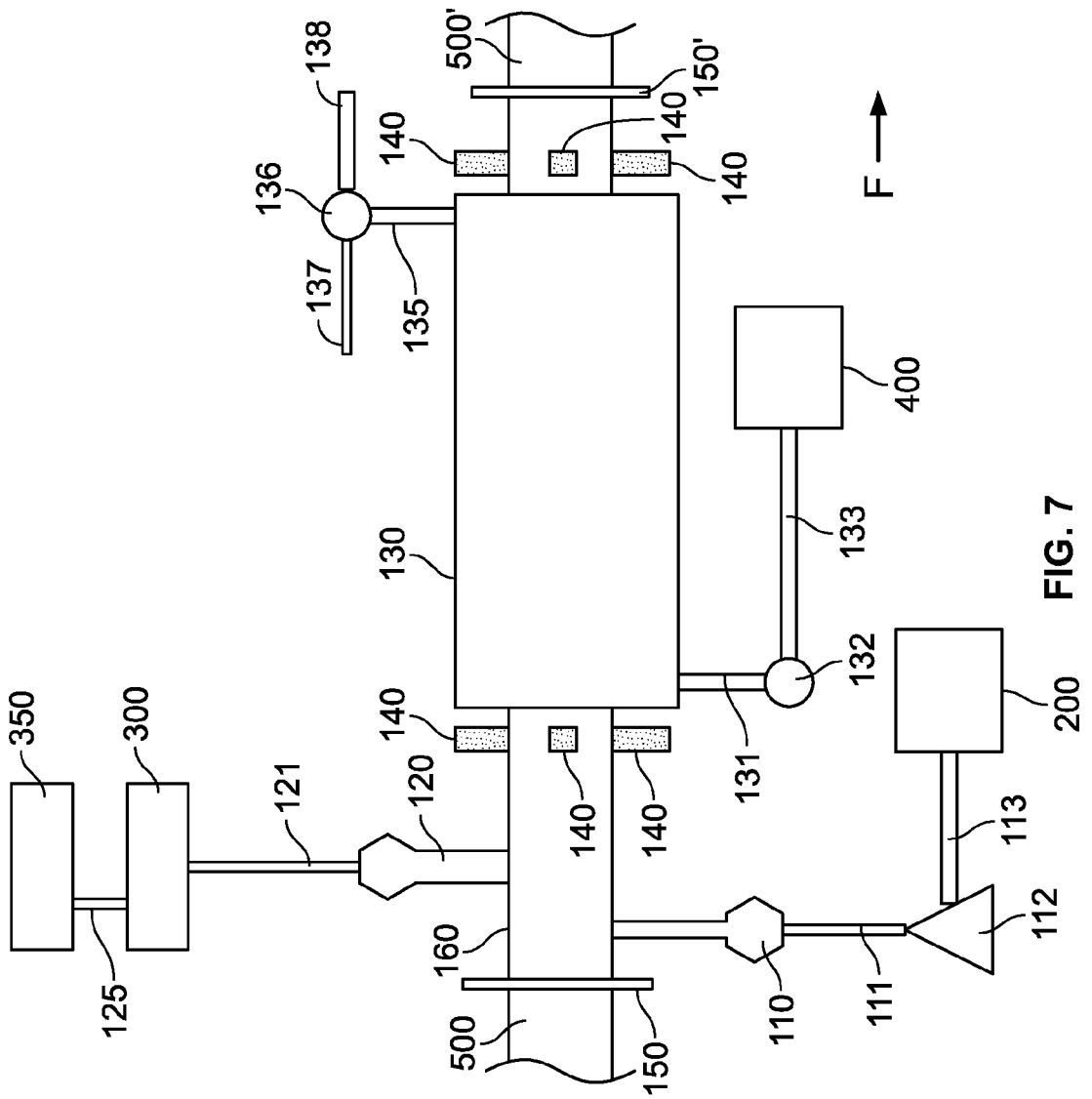

FIG. 7

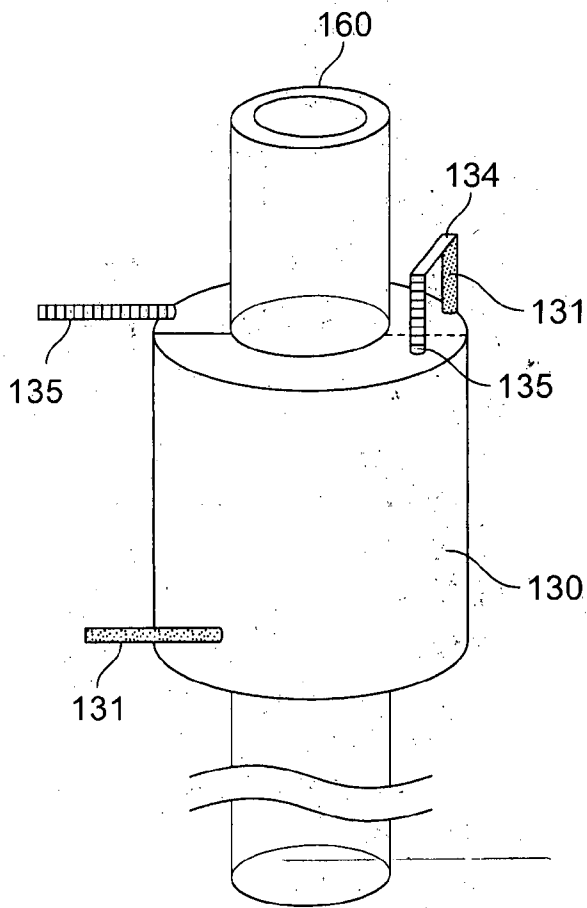

FIG. 8

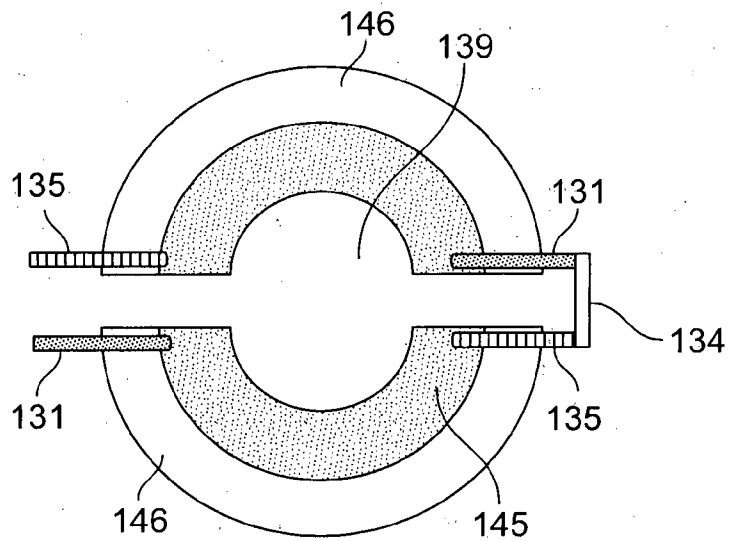

FIG. 9

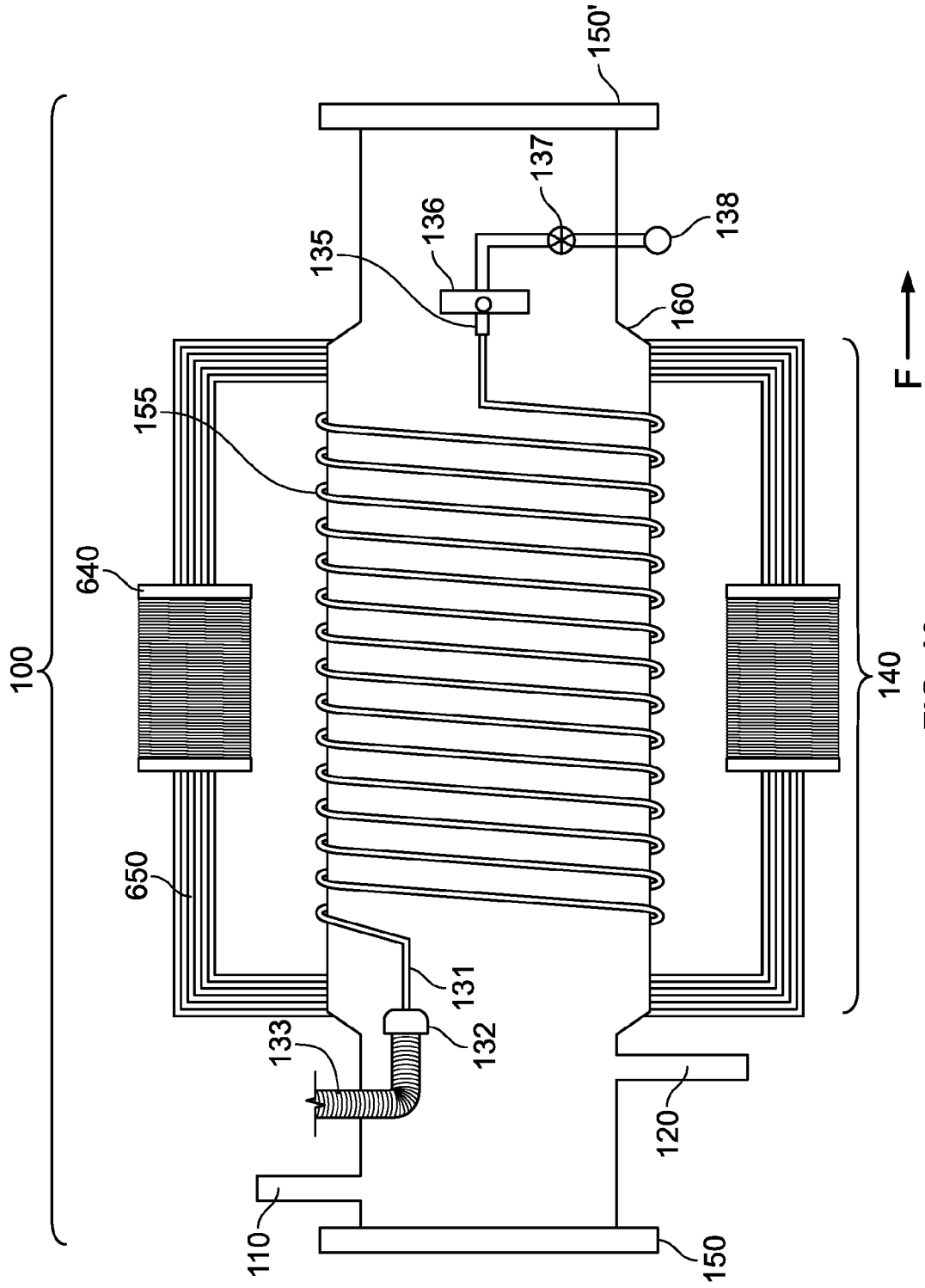

FIG. 10

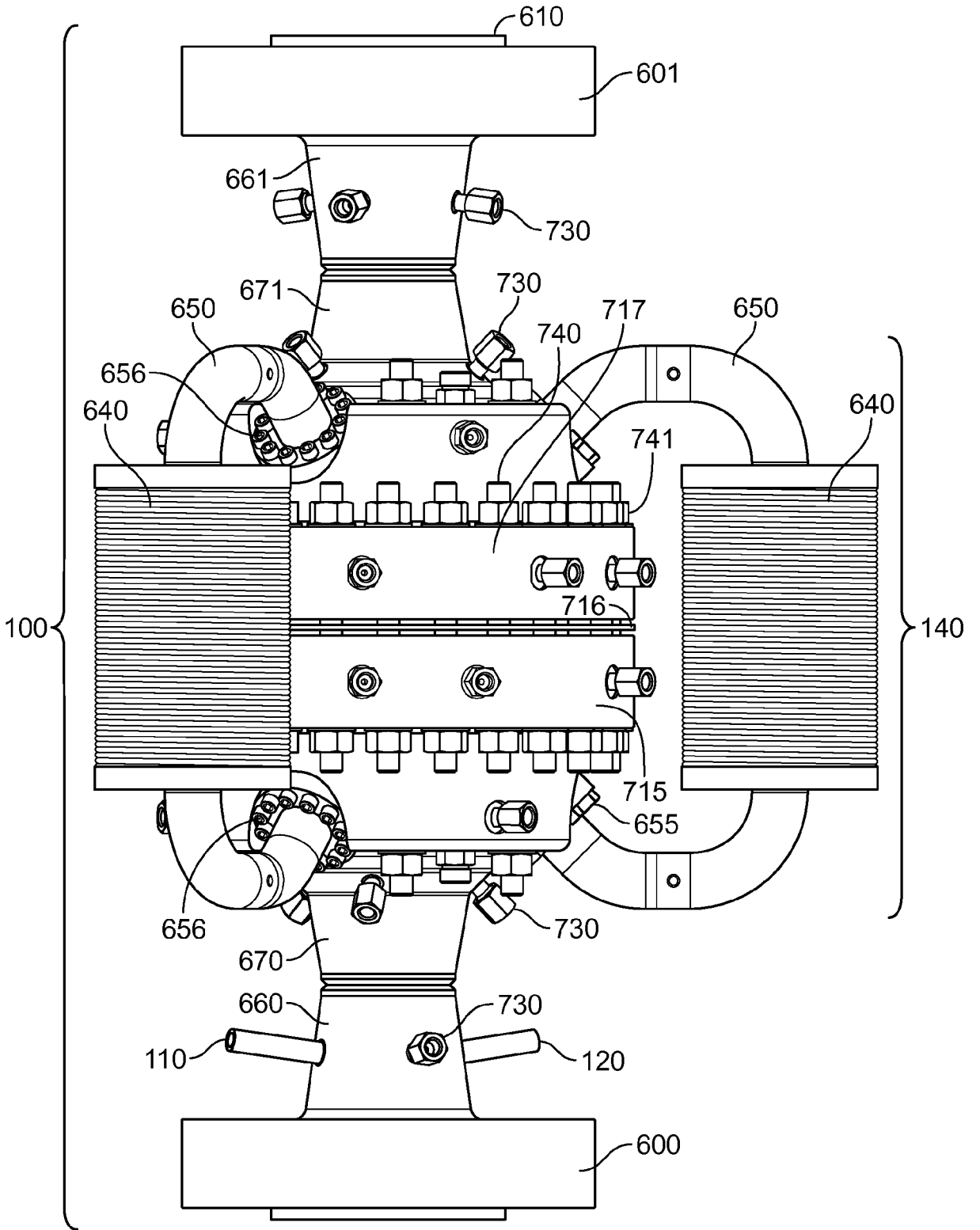

FIG. 11

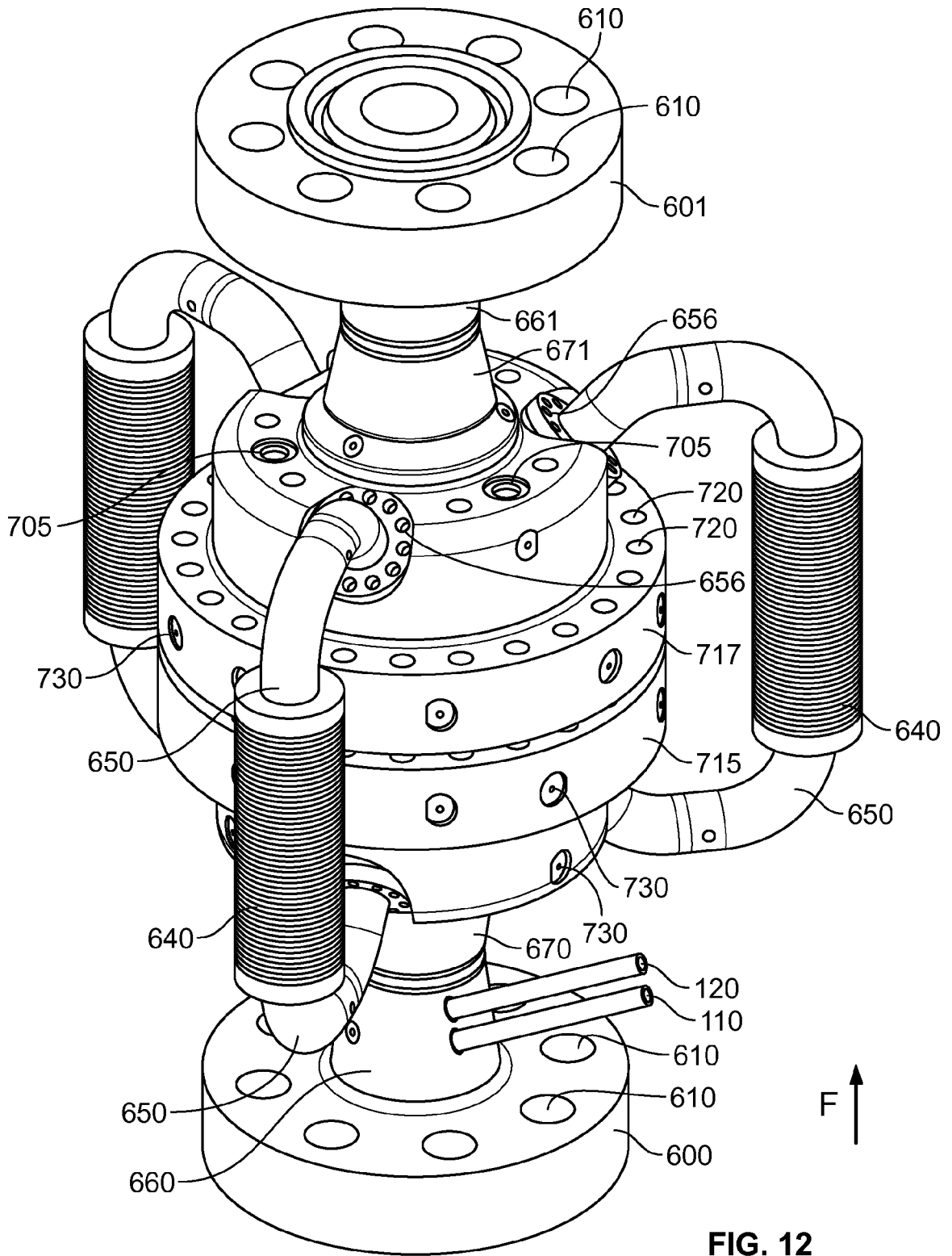

FIG. 12

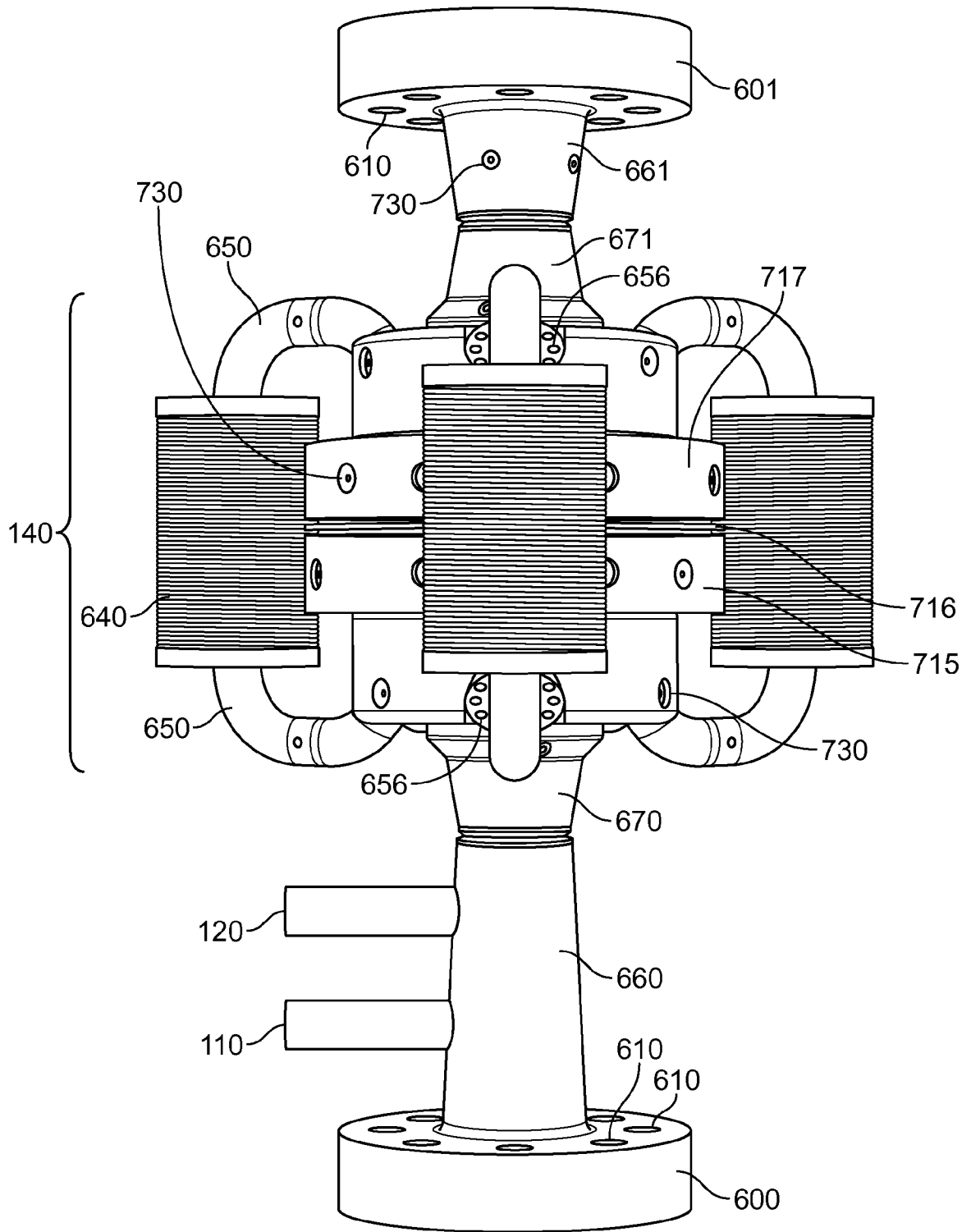

FIG. 13

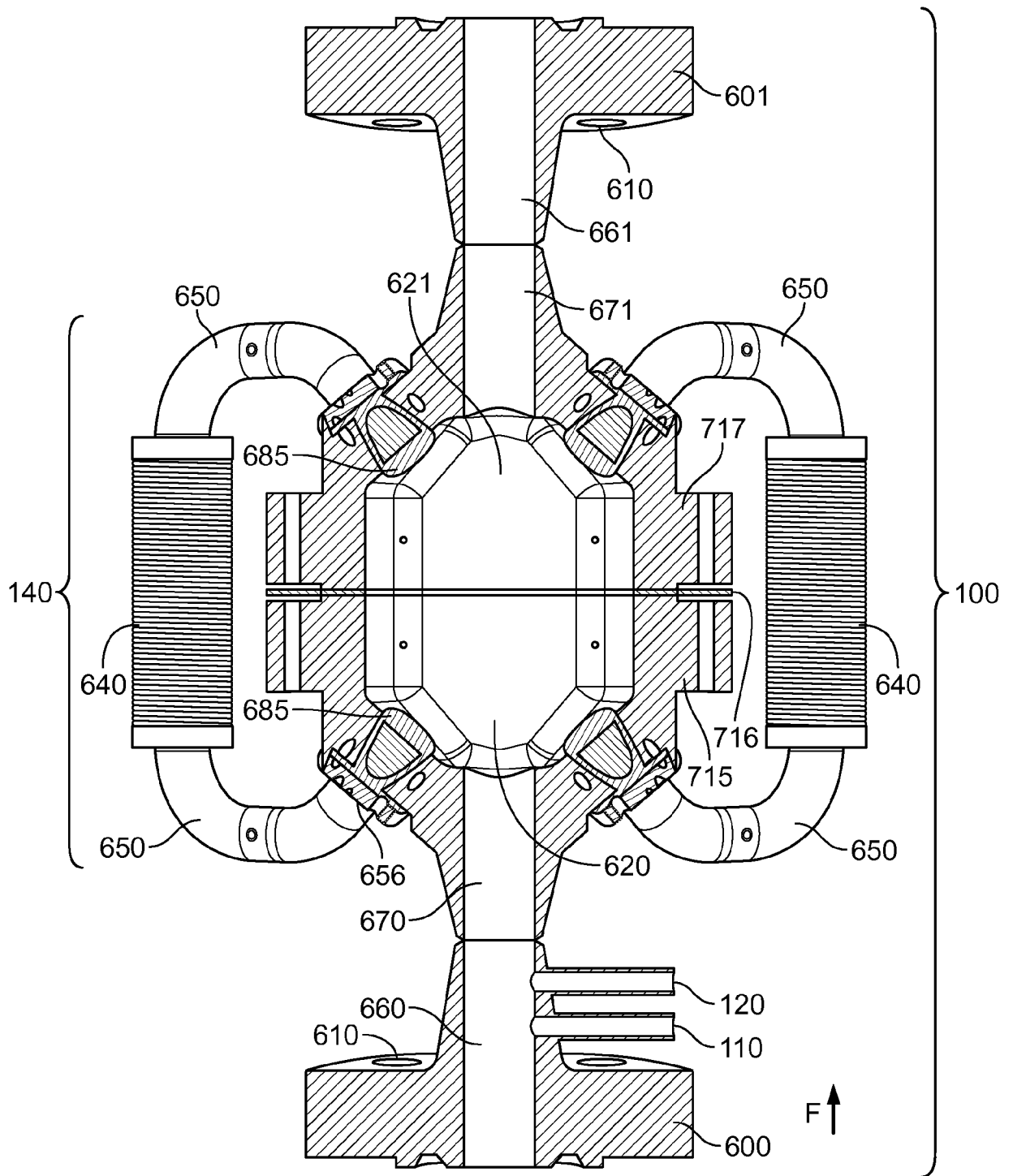

FIG. 14

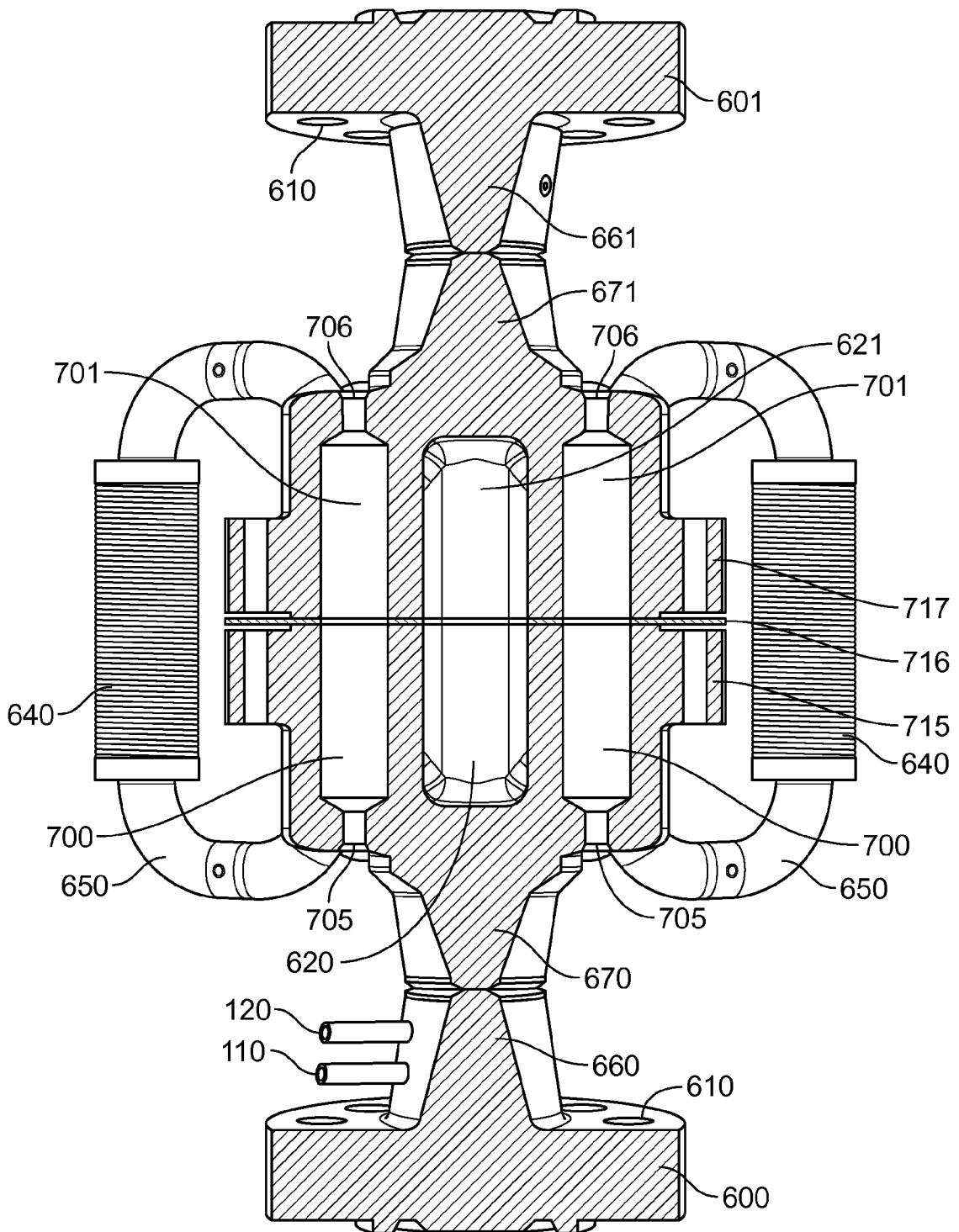

FIG. 15

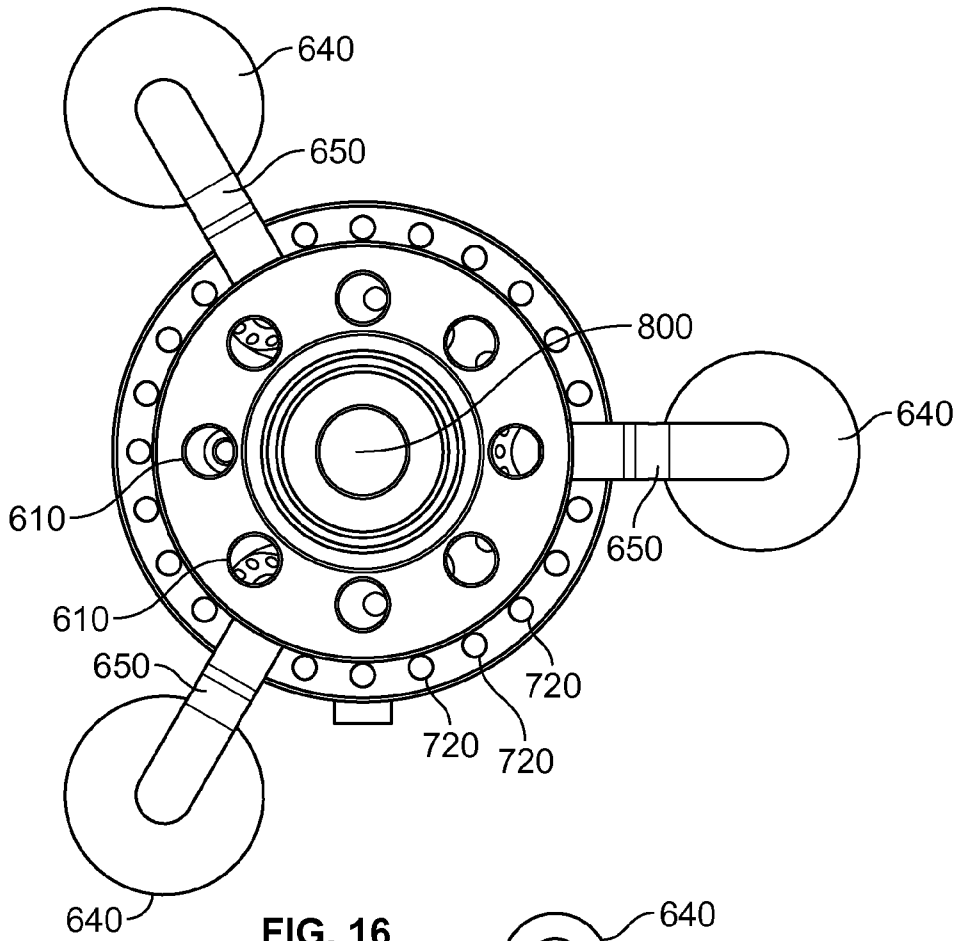

FIG. 16

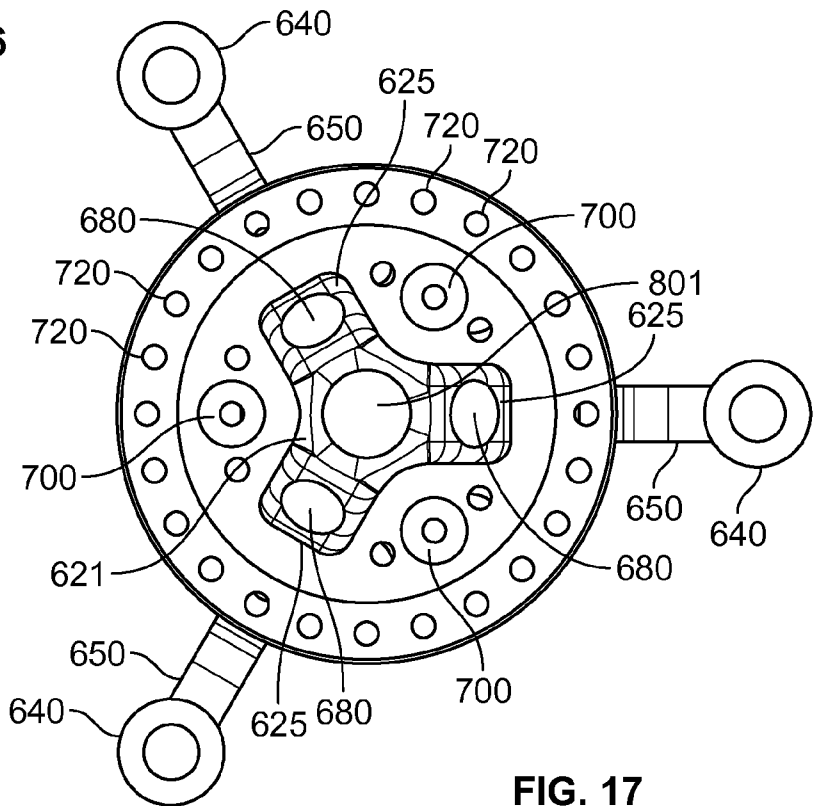

FIG. 17

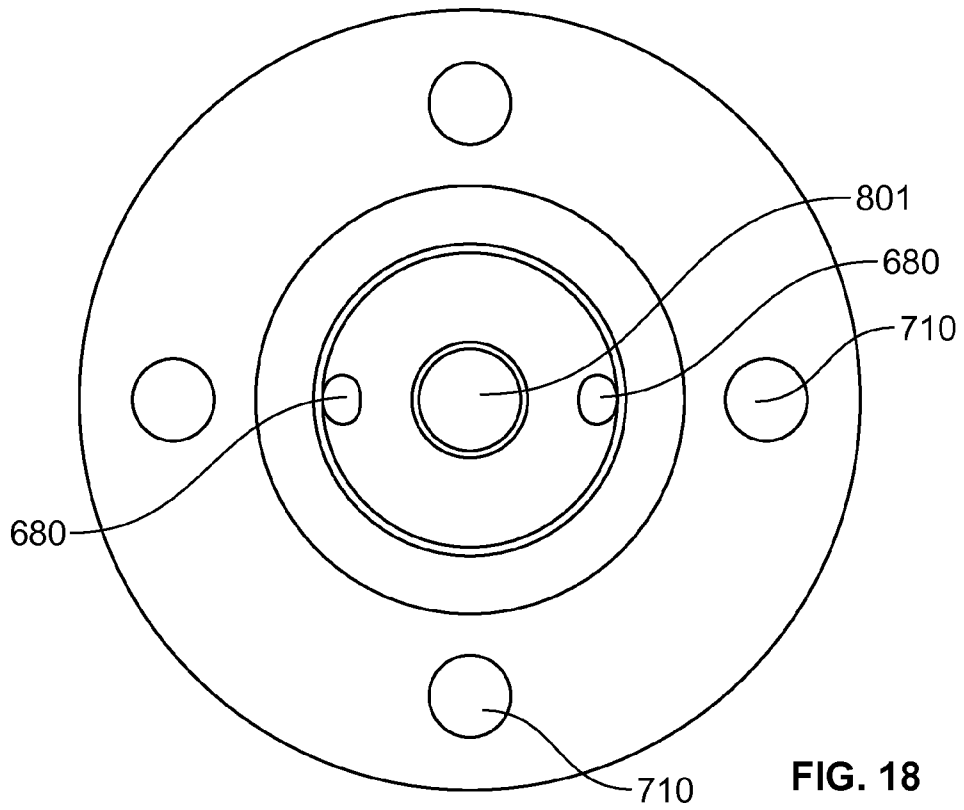

FIG. 18

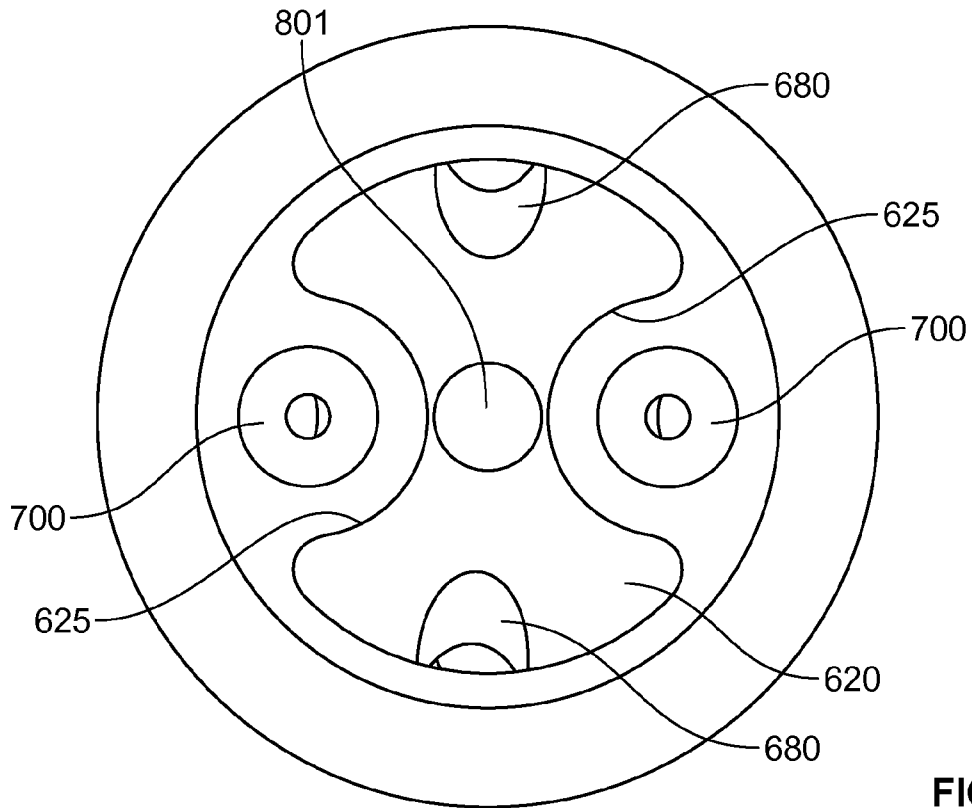

FIG. 19A

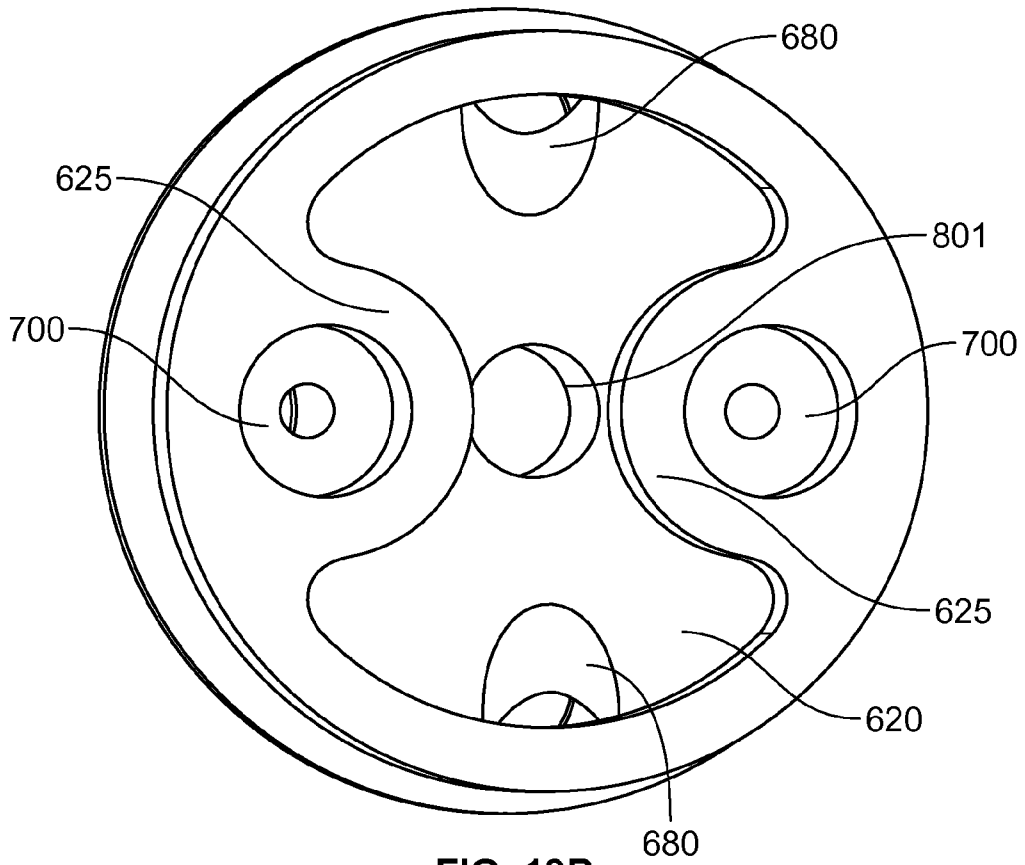

FIG. 19B

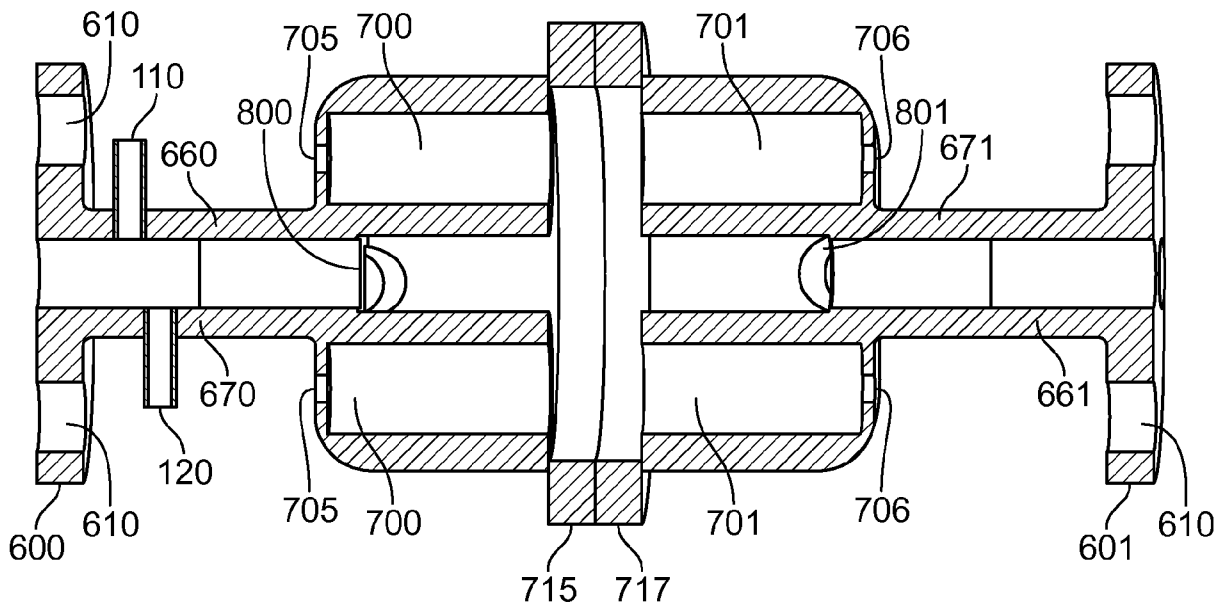
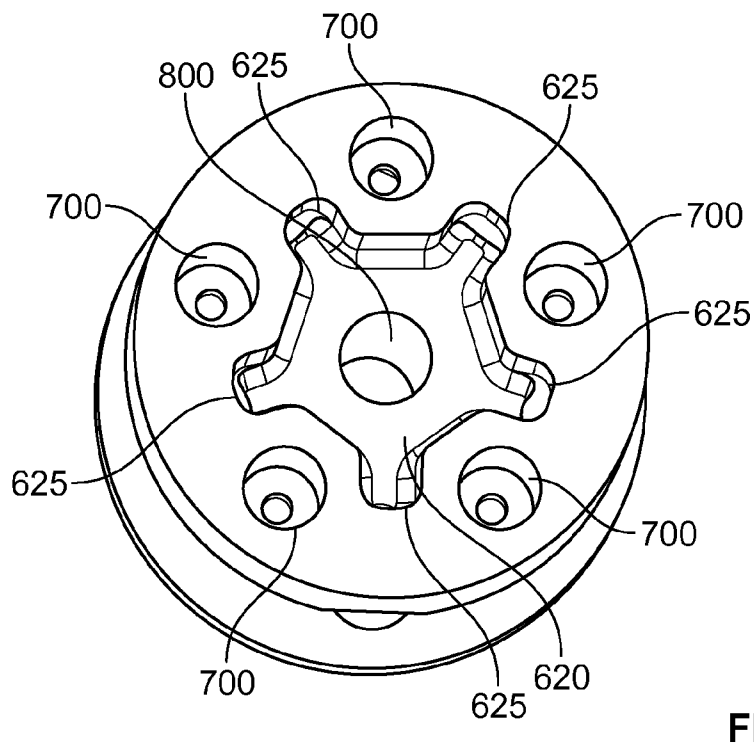
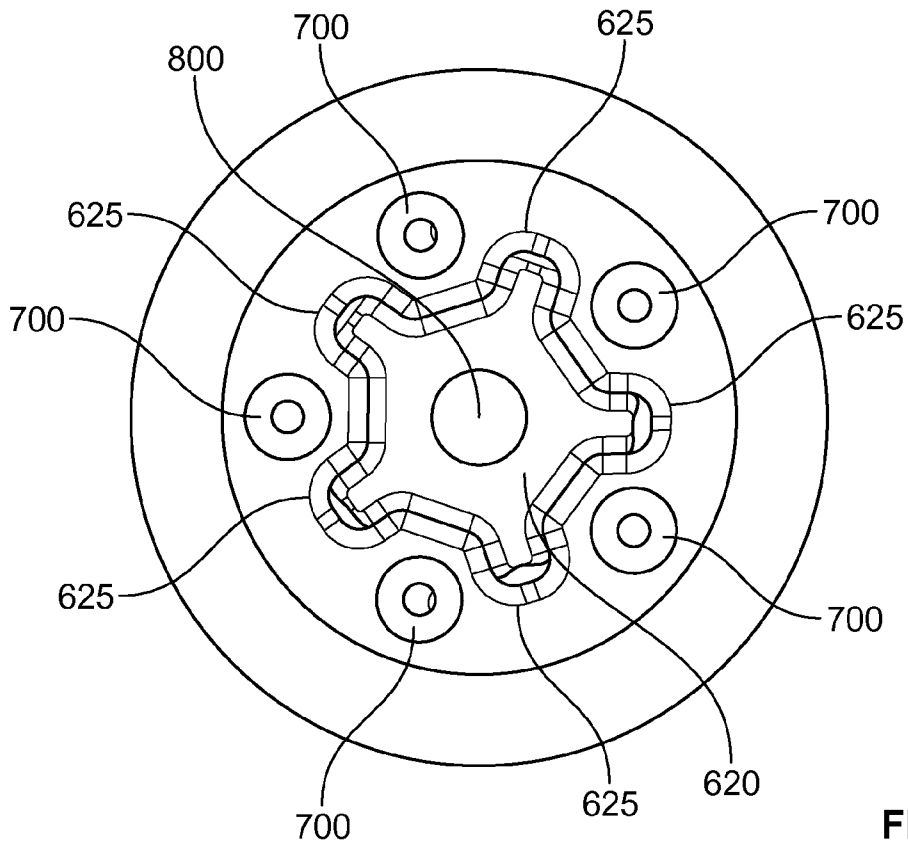

FIG. 20



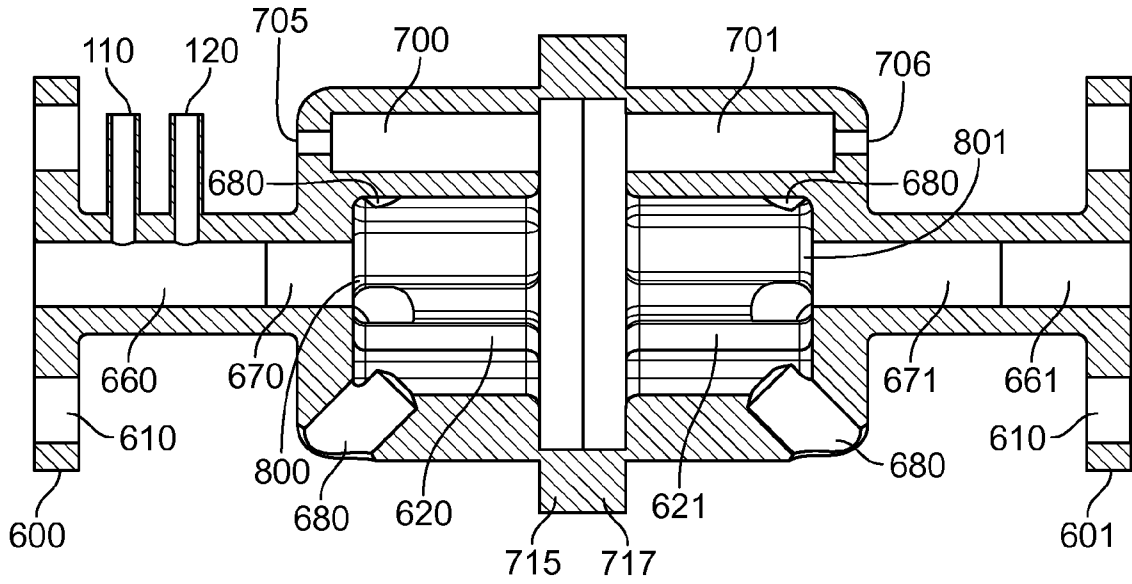

FIG. 22

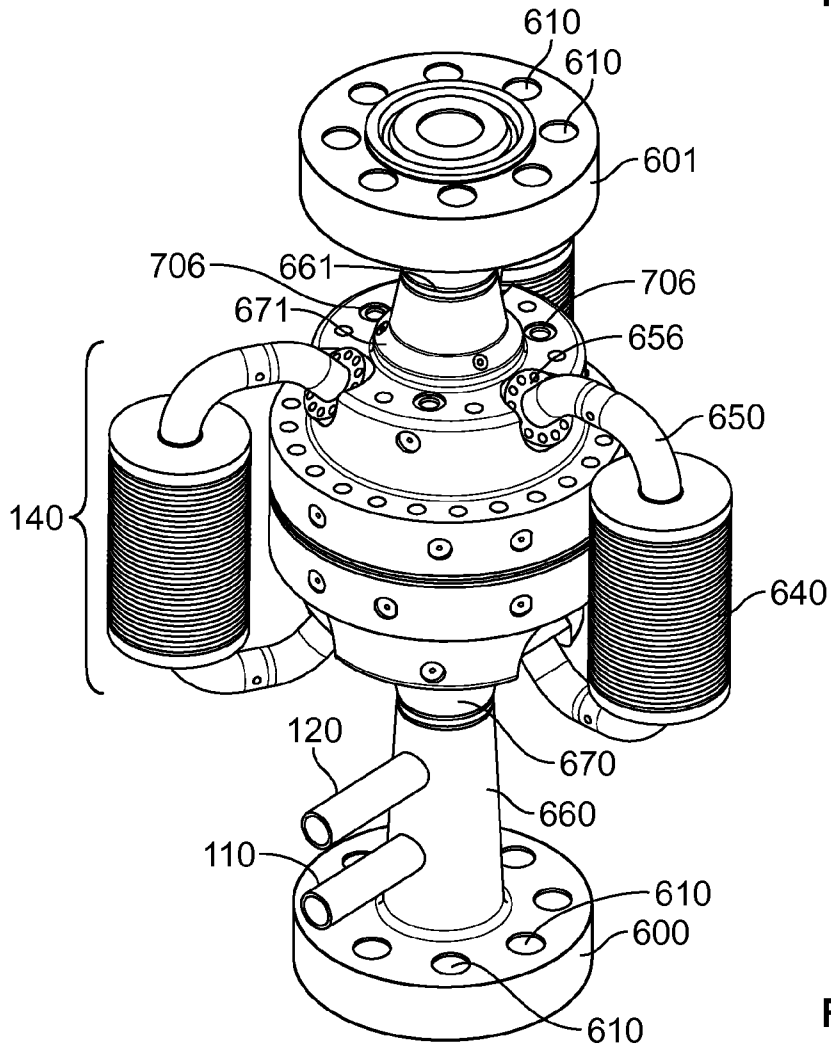

FIG. 23

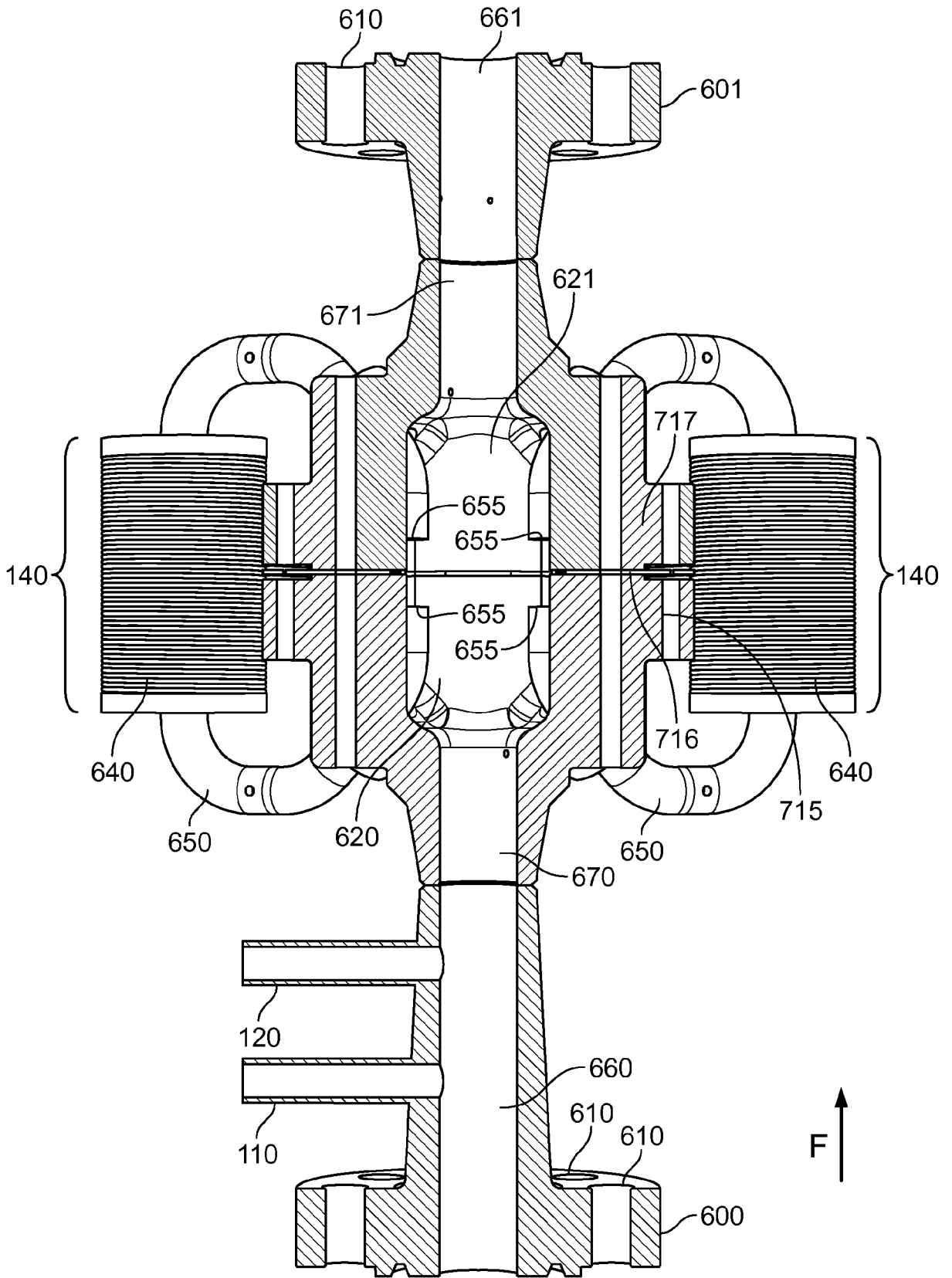

FIG. 24

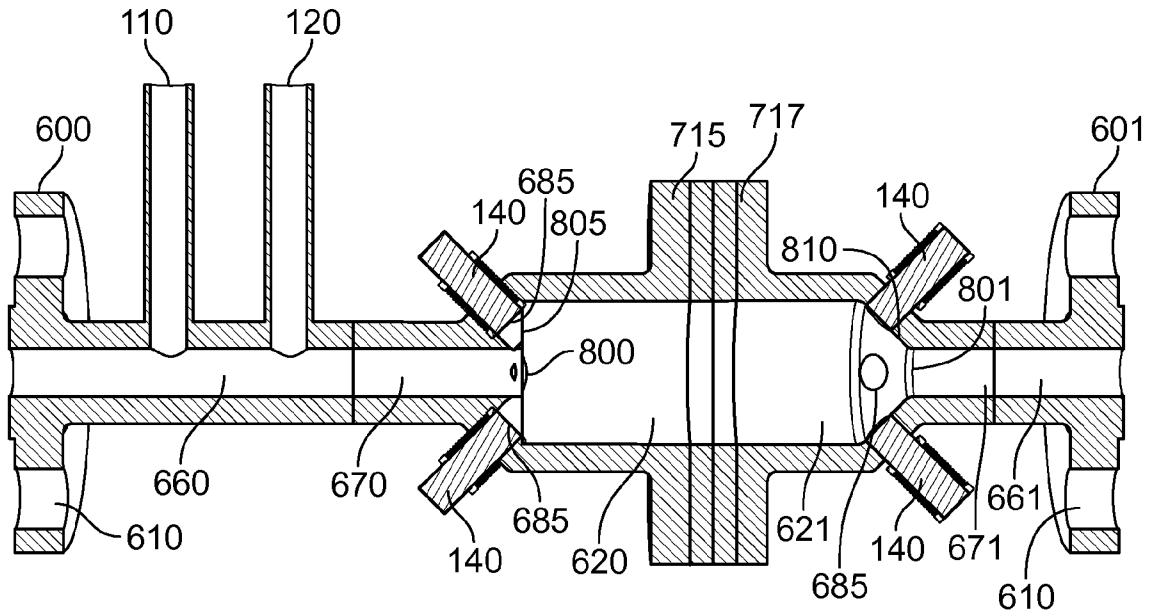

FIG. 25

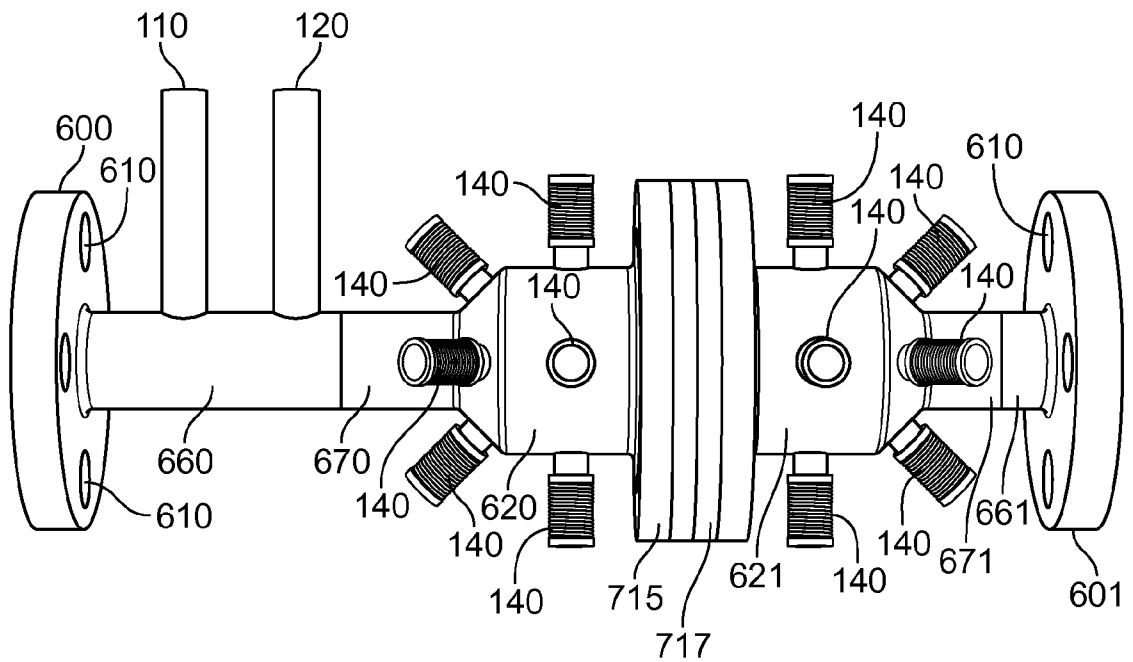

FIG. 26

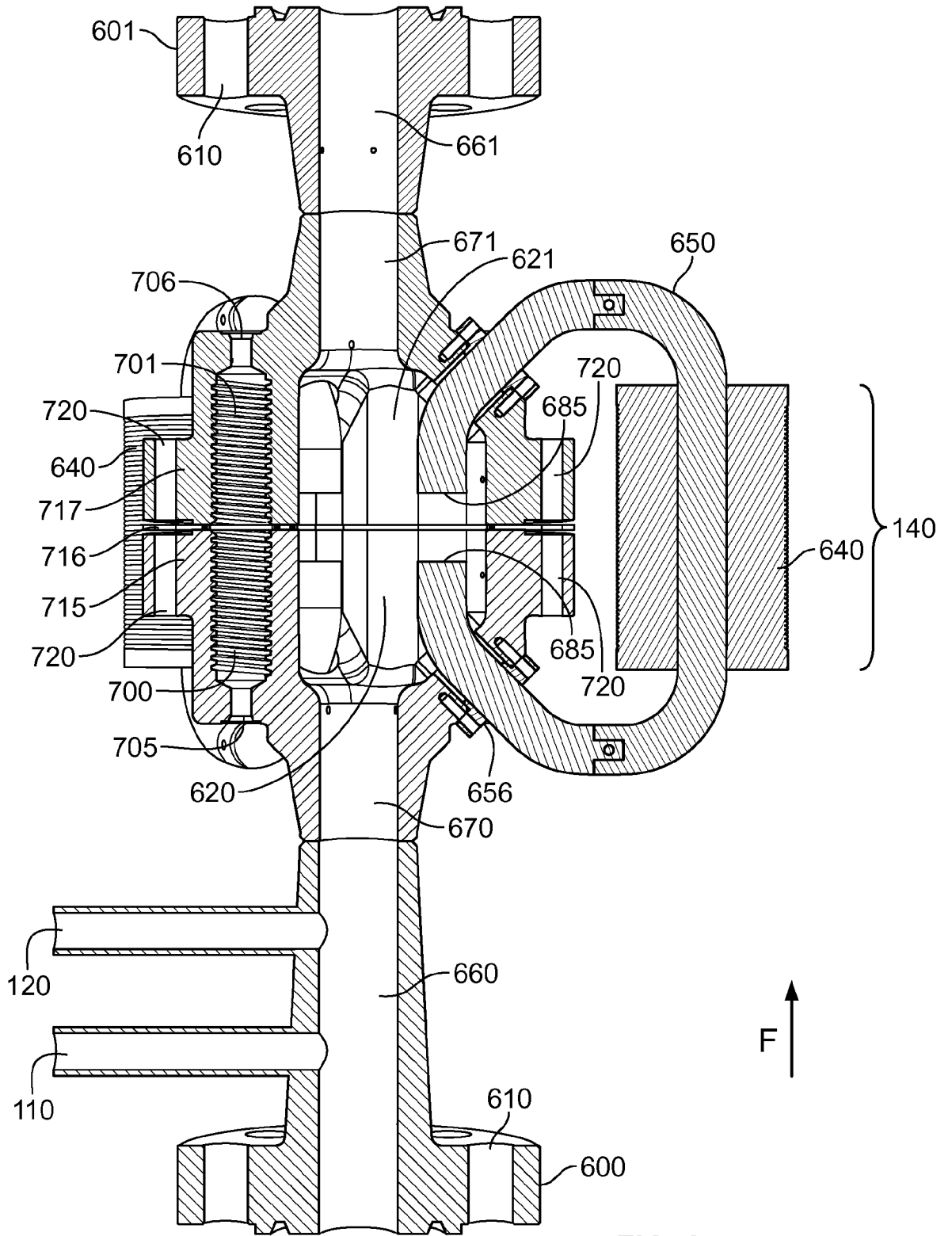

FIG. 27

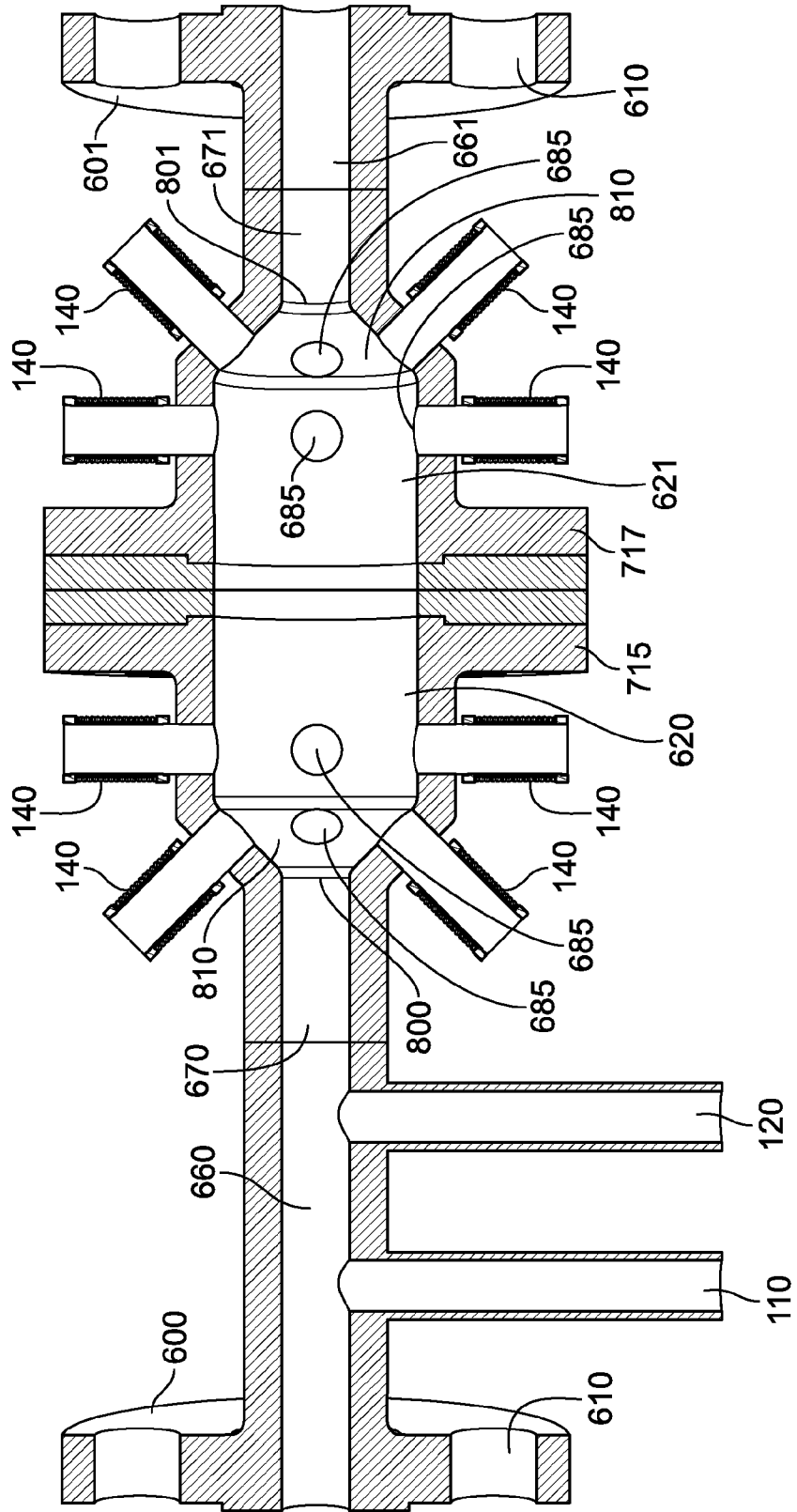

FIG. 28

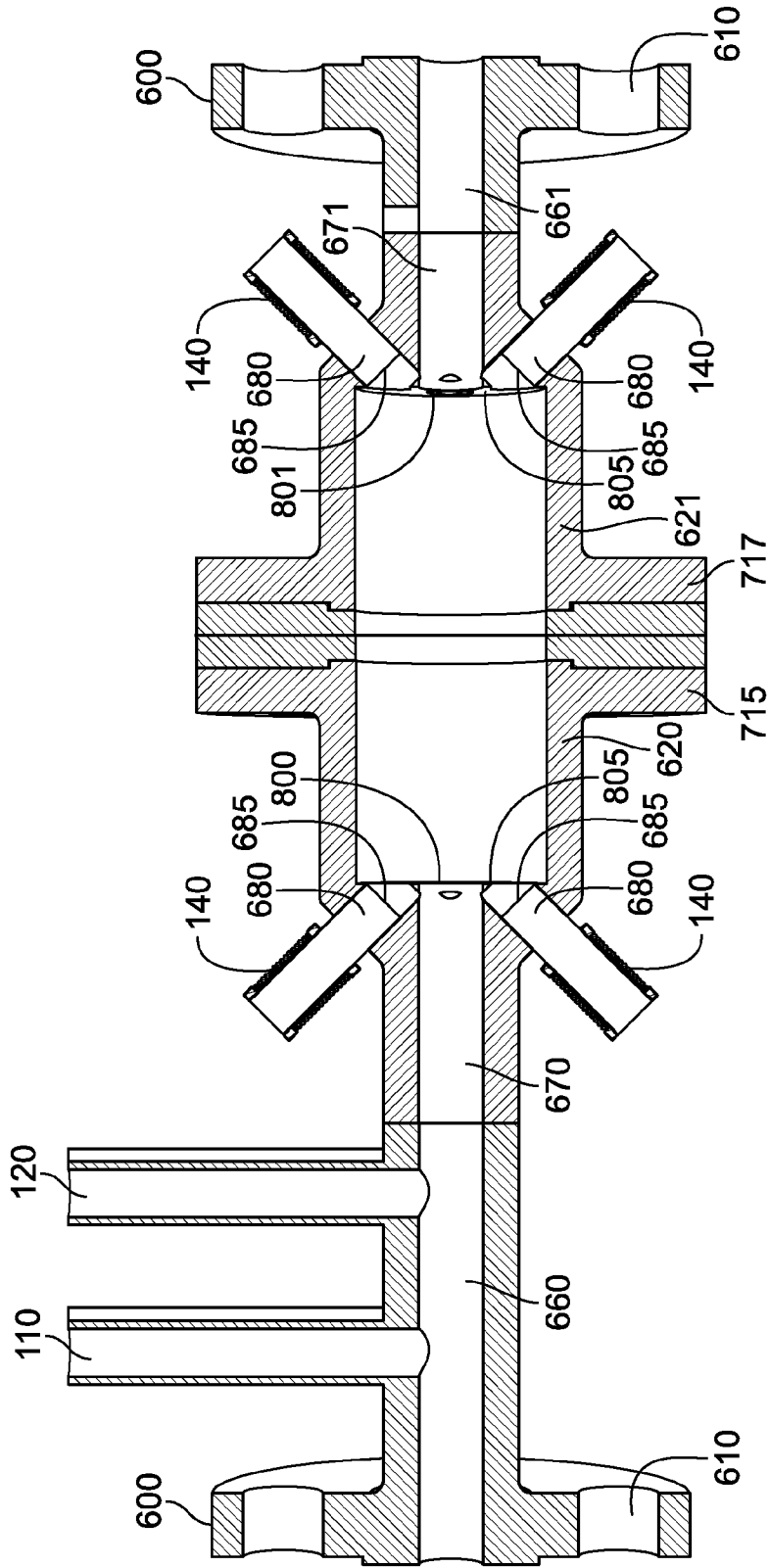

FIG. 29

INTERNATIONAL SEARCH REPORT

International application No
PCT/US2014/055495

A. CLASSIFICATION OF SUBJECT MATTER
INV. F16L55/10 E21B33/064 F15B21/06 F16L55/103
ADD.
According to International Patent Classification (IPC) or to both national classification and IPC

B. FIELDS SEARCHED
Minimum documentation searched (classification system followed by classification symbols)
F16L E21B F15B

Documentation searched other than minimum documentation to the extent that such documents are included in the fields searched

Electronic data base consulted during the international search (name of data base and, where practicable, search terms used)
EPO-Internal, WPI Data

C. DOCUMENTS CONSIDERED TO BE RELEVANT

Category*	Citation of document, with indication, where appropriate, of the relevant passages	Relevant to claim No.
X	WO 2011/145943 A1 (VORSCON HOLDING B V [NL]; VAN EIJK MARINUS [NL]) 24 November 2011 (2011-11-24)	1-6,111
Y	page 3 - page 8; figures	8-13
X	US 2011/297394 A1 (VANDELLEN JAY [US]) 8 December 2011 (2011-12-08) cited in the application paragraph [0045] - paragraph [0154]; figures	1-7,14, 15,111
Y	US 2011/192185 A1 (INGRAM MICHAEL T [US]) 11 August 2011 (2011-08-11) paragraph [0021] - paragraph [0039]; figures	8-13
	----- -/--	

Further documents are listed in the continuation of Box C.

See patent family annex.

* Special categories of cited documents :

- "A" document defining the general state of the art which is not considered to be of particular relevance
- "E" earlier application or patent but published on or after the international filing date
- "L" document which may throw doubts on priority claim(s) or which is cited to establish the publication date of another citation or other special reason (as specified)
- "O" document referring to an oral disclosure, use, exhibition or other means
- "P" document published prior to the international filing date but later than the priority date claimed

- "T" later document published after the international filing date or priority date and not in conflict with the application but cited to understand the principle or theory underlying the invention
- "X" document of particular relevance; the claimed invention cannot be considered novel or cannot be considered to involve an inventive step when the document is taken alone
- "Y" document of particular relevance; the claimed invention cannot be considered to involve an inventive step when the document is combined with one or more other such documents, such combination being obvious to a person skilled in the art
- "&" document member of the same patent family

Date of the actual completion of the international search 29 January 2015	Date of mailing of the international search report 10/02/2015
---	---

Name and mailing address of the ISA/ European Patent Office, P.B. 5818 Patentlaan 2 NL - 2280 HV Rijswijk Tel. (+31-70) 340-2040, Fax: (+31-70) 340-3016	Authorized officer Popescu, Alexandru
--	---

INTERNATIONAL SEARCH REPORT

International application No
PCT/US2014/055495

C(Continuation). DOCUMENTS CONSIDERED TO BE RELEVANT

Category*	Citation of document, with indication, where appropriate, of the relevant passages	Relevant to claim No.
A	WO 2011/153245 A1 (ADVANCED MAGNET LAB INC [US]; MEINKE RAINER [US]; SENTI MARK [US]; STE) 8 December 2011 (2011-12-08) abstract; figures -----	1,2

INTERNATIONAL SEARCH REPORT

International application No.
PCT/US2014/055495

Box No. II Observations where certain claims were found unsearchable (Continuation of item 2 of first sheet)

This international search report has not been established in respect of certain claims under Article 17(2)(a) for the following reasons:

1. Claims Nos.:
because they relate to subject matter not required to be searched by this Authority, namely:

2. Claims Nos.: 16-110, 112-147
because they relate to parts of the international application that do not comply with the prescribed requirements to such an extent that no meaningful international search can be carried out, specifically:
see FURTHER INFORMATION sheet PCT/ISA/210

3. Claims Nos.:
because they are dependent claims and are not drafted in accordance with the second and third sentences of Rule 6.4(a).

Box No. III Observations where unity of invention is lacking (Continuation of item 3 of first sheet)

This International Searching Authority found multiple inventions in this international application, as follows:

1. As all required additional search fees were timely paid by the applicant, this international search report covers all searchable claims.

2. As all searchable claims could be searched without effort justifying an additional fees, this Authority did not invite payment of additional fees.

3. As only some of the required additional search fees were timely paid by the applicant, this international search report covers only those claims for which fees were paid, specifically claims Nos.:

4. No required additional search fees were timely paid by the applicant. Consequently, this international search report is restricted to the invention first mentioned in the claims; it is covered by claims Nos.:

Remark on Protest

- The additional search fees were accompanied by the applicant's protest and, where applicable, the payment of a protest fee.
- The additional search fees were accompanied by the applicant's protest but the applicable protest fee was not paid within the time limit specified in the invitation.
- No protest accompanied the payment of additional search fees.

FURTHER INFORMATION CONTINUED FROM PCT/ISA/ 210

Continuation of Box II.2

Claims Nos.: 16-110, 112-147

The present application contains 147 claims. There are so many dependent claims, and they are drafted in such a way that the claims as a whole are not in compliance with the provisions of clarity and conciseness of Article 6 PCT, as they create a smoke screen in front of the skilled reader when assessing what should be the subject-matter to search. The non-compliance with the substantive provisions is to such an extent, that the search was performed taking into consideration the non-compliance in determining the extent of the search (PCT Guidelines 9.19).

The extent of the search was consequently limited to claims 1 to 15 and 111, which appears to comprise a reasonable definition of what is understood to be the invention for which protection is sought.

The applicant's attention is drawn to the fact that claims relating to inventions in respect of which no international search report has been established need not be the subject of an international preliminary examination (Rule 66.1(e) PCT). The applicant is advised that the EPO policy when acting as an International Preliminary Examining Authority is normally not to carry out a preliminary examination on matter which has not been searched. This is the case irrespective of whether or not the claims are amended following receipt of the search report or during any Chapter II procedure. If the application proceeds into the regional phase before the EPO, the applicant is reminded that a search may be carried out during examination before the EPO (see EPO Guidelines C-IV, 7.2), should the problems which led to the Article 17(2) declaration be overcome.

INTERNATIONAL SEARCH REPORT

Information on patent family members

International application No

PCT/US2014/055495

Patent document cited in search report	Publication date	Patent family member(s)	Publication date
WO 2011145943 A1	24-11-2011	EP 2715047 A1 NL 1037976 C US 2014318635 A1 WO 2011145943 A1	09-04-2014 22-11-2011 30-10-2014 24-11-2011

US 2011297394 A1	08-12-2011	US 2011297394 A1 WO 2011153524 A2	08-12-2011 08-12-2011

US 2011192185 A1	11-08-2011	NONE	

WO 2011153245 A1	08-12-2011	US 2013213512 A1 WO 2011153245 A1	22-08-2013 08-12-2011
