

Nov. 26, 1935.

W. E. MOLINS

2,022,569

GRINDING OF ROTATING ECCENTRIC KNIVES

Filed Dec. 2, 1933

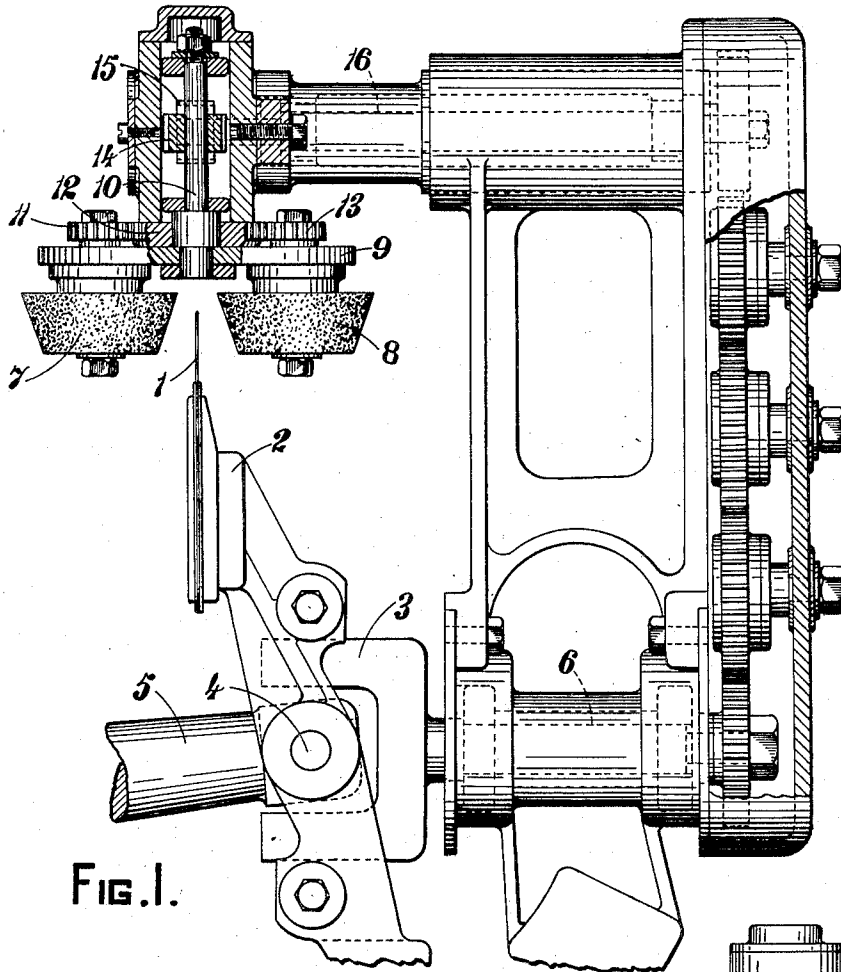

FIG. 1.

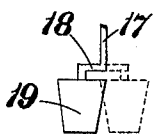

FIG. 3.

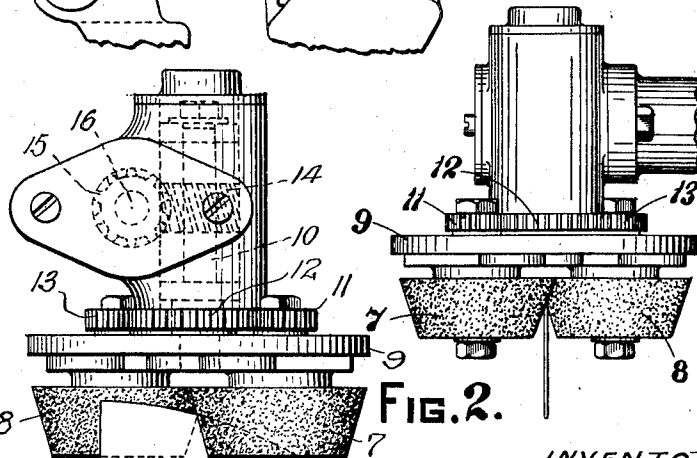
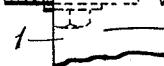

FIG. 2.

FIG. 4.



INVENTOR

W. E. Molins,
By Hutton, Coit, Ames & Grindle.
ATTYS.

UNITED STATES PATENT OFFICE

2,022,569

GRINDING OF ROTATING ECCENTRIC KNIVES

Walter Everett Molins, Deptford, London,
England

Application December 2, 1933, Serial No. 700,713
In Great Britain December 5, 1932

8 Claims. (Cl. 51—247)

This invention is for improvements in or relating to the grinding of rotating eccentric knives of the type in which the knife is mounted on a rotatable carrier, and has its edge eccentric to the axis of rotation of the knife and carrier, whether the knife rotates about an axis offset from the axis of the knife carrier, or whether the knife is fixed angularly relatively to the axis of the knife carrier, and whether or not the knife edge executes a movement in the direction of the axis of the knife carrier during the act of cutting.

According to the present invention there is provided apparatus for grinding knives of the type described comprising a grinding tool mounted on a rotatable support and so arranged relatively to the rotatable support as to be capable of engaging opposite sides of the knife alternately.

The invention will be more particularly described with reference to the accompanying drawing, in which:—

Figure 1 shows a side view partly in section of one form of the apparatus constructed in accordance with the present invention.

Figure 2 is a view of a portion of Figure 1 with some parts shown in different relative positions.

Figure 3 shows a modified form of the invention.

Figure 4 is an end elevation of a portion of the structure shown in Fig. 1.

Like reference numerals refer to like parts throughout the specification and drawing.

Referring to Figures 1 and 2, the knife 1 is fixed relatively to its axis of rotation, and is carried on a knife carrier 2 which is carried by a yoke member 3 of a universal joint 4 between two relatively inclined shafts 5 and 6. This knife is used for cutting the cigarette rod on a continuous rod cigarette machine and the shaft 5 supporting the knife is parallel to the cigarette rod. The shaft 5 is for the sake of convenience in the drawing shown inclined but in practice it is horizontal since the shaft is parallel to the cigarette rod. Figure 1 therefore should be tilted until the shaft 5 is horizontal.

The knife is arranged to rotate in such a manner that when the knife is intersecting the rod it will be moving at the same axial speed as the latter.

The grinder in this construction comprises two rotatable conical or frusto-conical rollers 7 and 8 which are arranged to grind both sides of the knife simultaneously at the time when the knife has no lateral movement or substantially no lateral movement.

The rollers 7 and 8 are carried on spindles which are attached to a disc 9 supported by a rotatable support 10 and are offset from the rotatable support. The axes of the rollers 7 and 8 and the axis of the rotatable support 10 are preferably parallel to each other and all lie in the same plane. As shown in the drawing, the rollers 7 and 8 are continuously rotated through the medium of the gears 11, 12 and 13. This gearing is of the conventional planetary type, the gear 12 being secured to the housing which encloses the rotatable support 10 and functioning as a sun gear. The disc 9 which is secured to the rotatable support 10 carries the planet gears 11 and 13 which are in mesh with the sun gear 12 and which are consequently rotated on their own axes upon rotation of the support 10. The gears 11 and 13 are secured for rotation with the respective rollers 7 and 8. If desired, the gears may be dispensed with and the rollers 7 and 8 may be mounted upon their spindles in such a manner that they are freely rotatable about their spindles and are caused to rotate by frictional contact with the knife during the sharpening operation.

The disc 9 fixed to the rotatable support 10 is caused to rotate by gears 14 and 15, the gear 15 being attached to a spindle 16 which is rotated by a train of gears, one of which is connected to the shaft 6.

At the instant of grinding, the relative positions of the rollers 7 and 8 and the knife 1 are as shown in Figure 2, and as the knife 1 continues its rotational movement the disc 9 also continues to rotate, the grinders 7 and 8 being again brought into the grinding position at the time when the knife again arrives at the said position. If desired, the relative speed of the rotatable support 10 to the knife carrier, may be 1:2 in which case the disc 9 will only have travelled through 180° whilst the knife has completed one revolution, but owing to the disposition of the rollers 7 and 8 the knife will be ground when it arrives at the grinding position. It will be readily understood that the velocity ratio may be 1:1.

Referring to Figure 3, the rotatable shaft 17 is vertically disposed and arranged to be driven in a manner similar to that described with reference to the support 10, with reference to Figures 1 and 2, instead, however, of being provided with a disc 9, a crank 18 is provided to which the spindle of a grinding roller is attached, the spindle being offset from the rotatable shaft. In this instance, the ratio of angular velocity of the grinder support 17 is 1:2 of that of the knife

carrier, so that at one revolution of the knife, the knife will contact with the grinder as shown in full lines, whilst at the next rotation of the knife, the grinder will have assumed the position shown in chain line, and the opposite side of the knife will be ground.

It will be appreciated that in this construction the eccentricity of the knife edge is allowed for by reason of the angular rotation of the rotatable shaft. The grinder is so arranged that when the knife first engages it, the distance from the centre of the grinder to the knife edge will be less than when the trailing edge is passing the grinder face. Thus, the effect of rotation of the grinder shaft after the knife first engages the grinder, is to move the centre of the grinder away from the knife edge, thus allowing for the radial increase of the latter. Since the ratio of the angular velocity of the grinder support is 1:2 of that of the knife carrier, exactly the same effect will result on the opposite face of the knife the next time the knife approaches the same position relatively to the cigarette rod.

Thus it will be seen that by either of the alternative constructions described with reference to the drawing, there is provided a grinder which will operate on both sides of the knife and grind an eccentric edge on the latter although there is no lateral movement or substantially no lateral movement of the knife.

It will be appreciated that the grinder may be used for any other type of eccentric knife and is not limited in its use to the particular construction of knife described hereinbefore by way of example only, and further, with suitable speed ratio of the grinder support to the knife carrier, it is possible to grind the knife edge whilst the knife is moving axially.

What I claim as my invention and desire to secure as Letters Patent is:—

1. Apparatus for grinding an eccentric knife which rotates about an axis, comprising in combination a support rotatable about an axis which is substantially radial to the axis of rotation of the knife, said support axis lying substantially in the plane of the knife during the time that the latter is to be ground, means for driving the said support in timed relationship with the knife, and at least one grinding roller mounted eccentrically on the said support.

2. Apparatus for grinding an eccentric knife which rotates about an axis, comprising in combination a support rotatable about an axis which is substantially radial to the axis of rotation of the knife, said support axis lying substantially in the plane of the knife during the time that the latter is to be ground, means for driving the said support in timed relationship with the knife, and at least one conical grinding roller mounted eccentrically on the said support.

3. Apparatus for grinding an eccentric knife which rotates about an axis, comprising in combination a support rotatable about an axis which is substantially radial to the axis of rotation of the knife, said support axis lying substantially in the plane of the knife during the time that

the latter is to be ground, means for driving the said support in timed relationship with the knife, and at least one grinding roller mounted eccentrically on the said support, said grinding roller having an axis, which lies in substantially the same plane as the axis of rotation of the said support.

4. Apparatus for grinding an eccentric knife which rotates about an axis, comprising in combination a support rotatable about an axis which is substantially radial to the axis of rotation of the knife, said support axis lying substantially in the plane of the knife during the time that the latter is to be ground, means for driving the said support in timed relationship with the knife, and at least one grinding roller mounted eccentrically on the said support, said roller having an axis which is parallel to the axis of rotation of the support.

5. Apparatus for grinding an eccentric knife which rotates about an axis, comprising in combination a support rotatable about an axis which is substantially radial to the axis of rotation of the knife, said support axis lying substantially in the plane of the knife during the time that the latter is to be ground, means for driving the support in timed relationship with the knife, two grinding rollers mounted eccentrically and symmetrically on the rotatable support.

6. Apparatus for grinding an eccentric knife which rotates about an axis, comprising in combination a support rotatable about an axis which is substantially radial to the axis of rotation of the knife, said support axis lying substantially in the plane of the knife during the time that the latter is to be ground, means for driving the support in timed relationship with the knife, and two conical grinding rollers mounted eccentrically and symmetrically on the said support.

7. Apparatus for grinding an eccentric knife which rotates about an axis, comprising in combination a support rotatable about an axis which is substantially radial to the axis of rotation of the knife, said support axis lying substantially in the plane of the knife during the time that the latter is to be ground, means for driving the support in timed relationship with the knife, and two grinding rollers mounted eccentrically and symmetrically on the rotatable support, said rollers having axes which lie in substantially the same plane as the axis of rotation of the said support.

8. Apparatus for grinding an eccentric knife which rotates about an axis, comprising in combination a support rotatable about an axis which is substantially radial to the axis of rotation of the knife, said support axis lying substantially in the plane of the knife during the time that the latter is to be ground, means for driving the support in timed relationship with the knife, and two grinding rollers mounted eccentrically and symmetrically on the rotatable support, said rollers having axes which are parallel to the axis of rotation of the latter.