



US 20050072195A1

(19) **United States**

(12) **Patent Application Publication**
McEachern

(10) **Pub. No.: US 2005/0072195 A1**

(43) **Pub. Date: Apr. 7, 2005**

(54) **CHEMICAL DISPENSER**

Publication Classification

(75) **Inventor: Dennis McEachern, Concord, NC (US)**

(51) **Int. Cl.7** **D06F 39/08**

(52) **U.S. Cl.** **68/12.01; 68/12.18; 68/13 R;**
68/13 A; 68/207; 68/183

Correspondence Address:

DENNISON, SCHULTZ & DOUGHERTY

Suite 612

1745 Jefferson Davis Highway

Arlington, VA 22202-3417 (US)

(57)

ABSTRACT

(73) **Assignee: LAUNDROX, INC.**

A portable chemical dispenser having a gas generator removably secured on a vertical support stand, a liquid dispenser supported on a horizontal support base, wherein the vertical support stand is attached to the horizontal support base.

(21) **Appl. No.: 10/676,183**

(22) **Filed: Oct. 2, 2003**

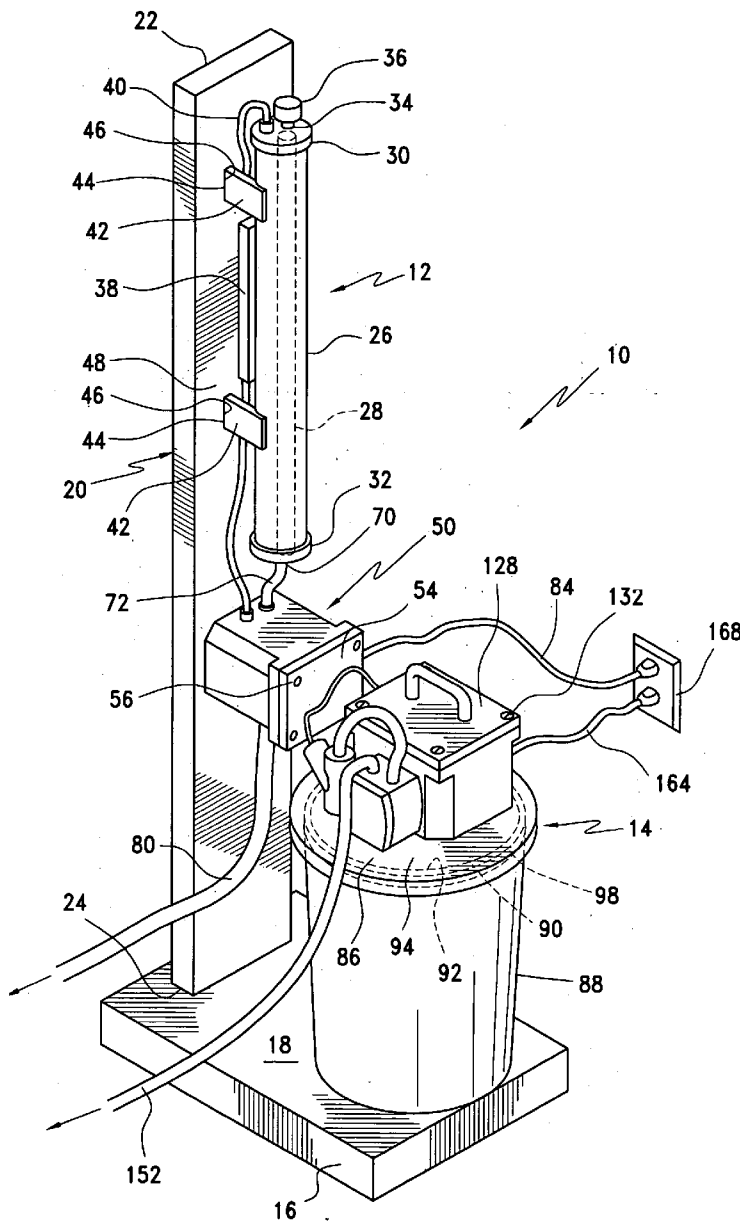

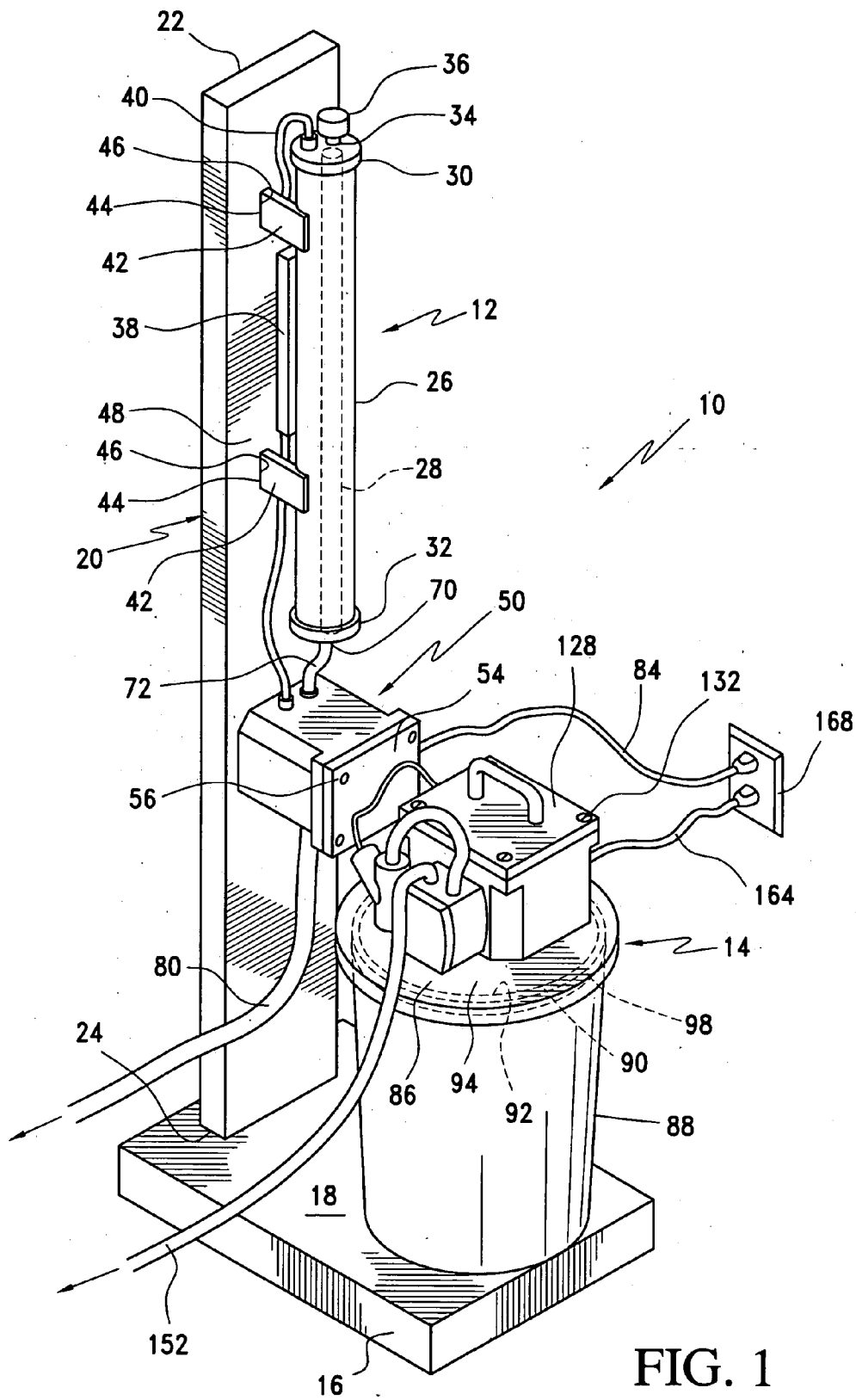

FIG. 1

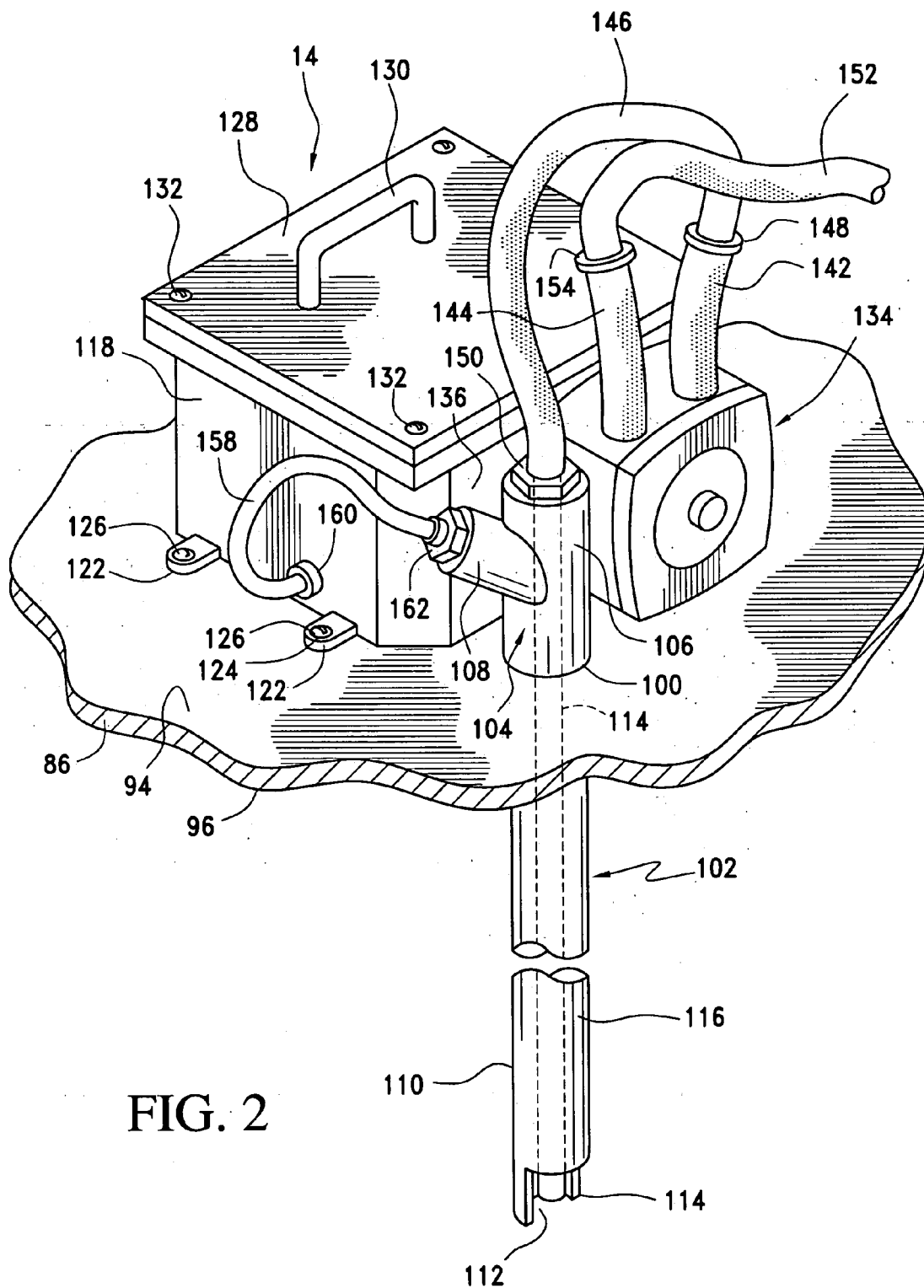

FIG. 2

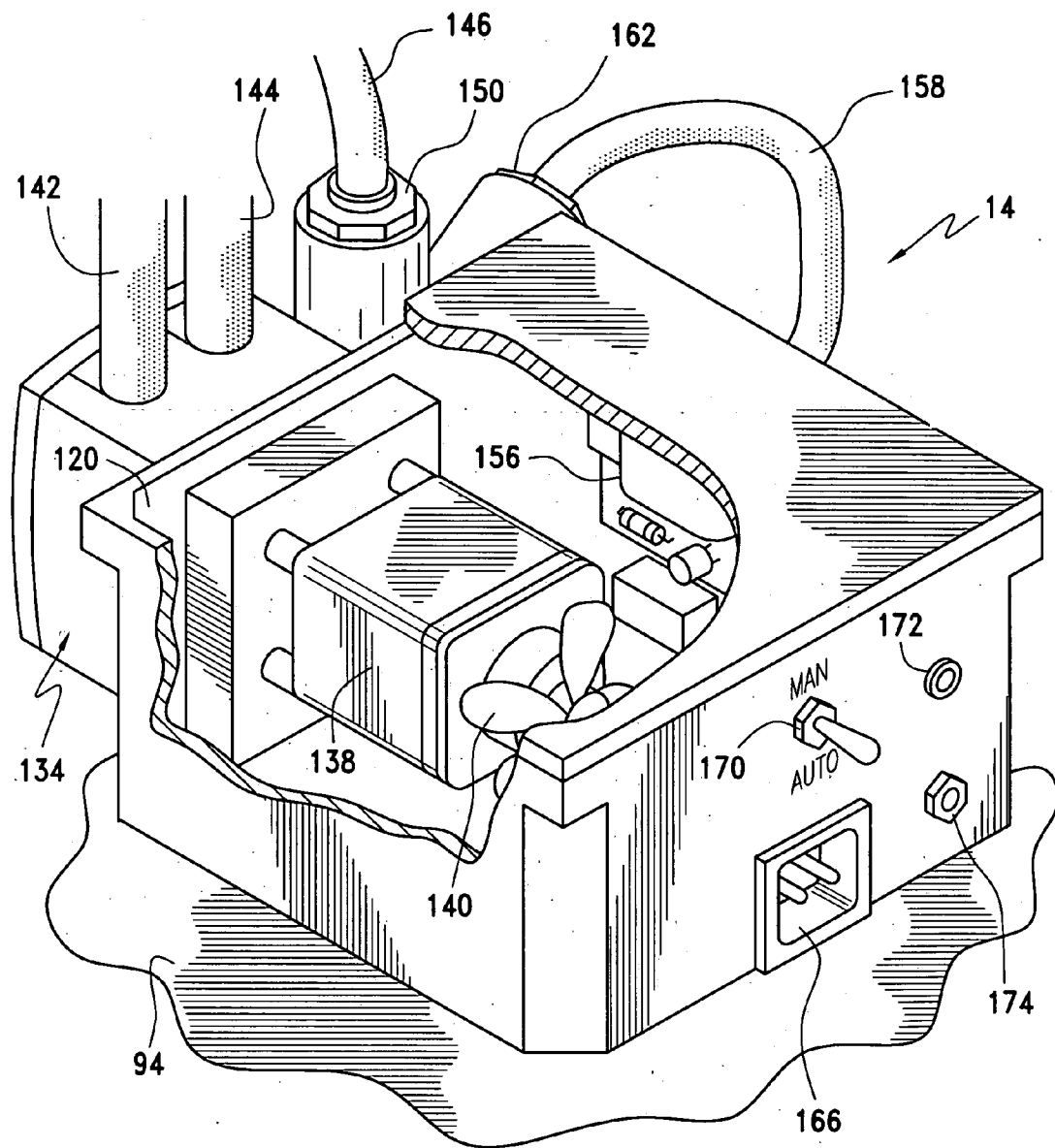

FIG. 3

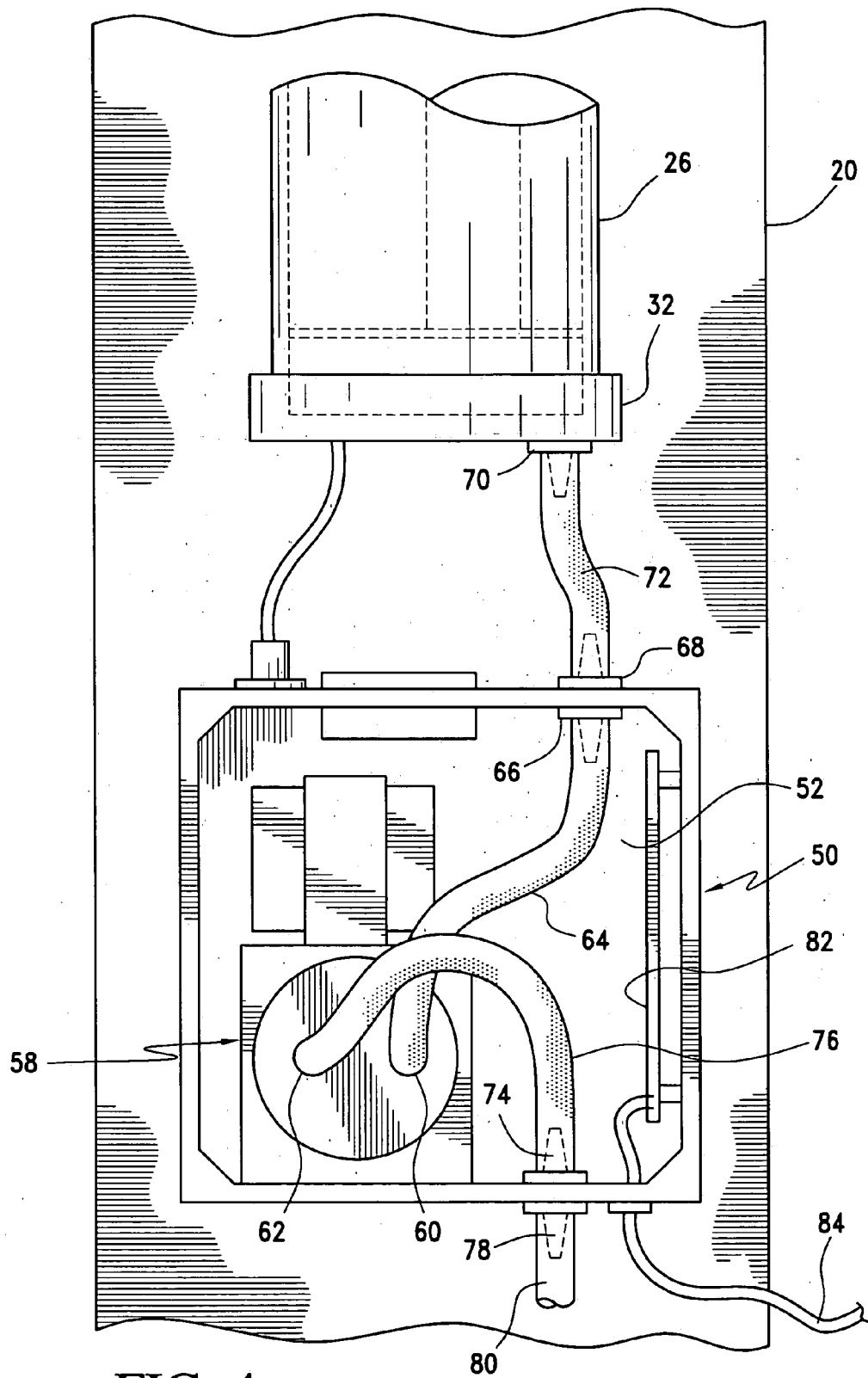

FIG. 4

CHEMICAL DISPENSER

TECHNICAL FIELD

[0001] The present invention is directed toward chemical dispensers, and more particularly, toward a portable combined liquid dispenser and gas generator for commercial washing machines.

BACKGROUND OF THE INVENTION

[0002] Chemical dispensers are commonly used in the commercial laundry industry to provide various chemicals to washing machines at the proper time in the cycle. Conventional chemical dispensers used in commercial laundry industry are sophisticated and expensive systems that include many tubes and components and are mounted on the wall or a support wall proximate the laundry machine.

[0003] The utilization of activated oxygen, or ozone, to clean and disinfect is well known where ozone is created when oxygen comes in contact with either ultraviolet light or electricity. However, there has not been a liquid detergent or chemical dispenser combined with a light ozone generator that are comparably workable together.

[0004] Therefore, it is presently believed that there is a need for a chemical dispenser operable with commercial laundry machines, which chemical dispenser can also be portable and be utilized with an ozone gas generator to provide superior cleaning and disinfecting effects.

SUMMARY OF THE INVENTION

[0005] A portable chemical dispenser having a gas generator removably secured on a vertical support stand, a liquid dispenser supported on a horizontal support base, wherein the vertical support stand is attached to the horizontal support base.

BRIEF DESCRIPTION OF THE DRAWINGS

[0006] The above-described and other features and advantages of the present invention will be appreciated and understood by those skilled in the art from the detailed description of the invention that follows and the following drawings wherein:

[0007] FIG. 1 is a perspective view of a chemical dispenser according to the present invention;

[0008] FIG. 2 is an front perspective view of the liquid dispenser apparatus of the chemical dispenser;

[0009] FIG. 3 is a rear perspective view of the liquid dispenser apparatus shown in FIG. 2 illustrating its internal components; and,

[0010] FIG. 4 is a side sectional view of the gas generator apparatus of the chemical dispenser.

DETAILED DESCRIPTION OF THE PREFERRED EMBODIMENT

[0011] Referring now to the drawings, wherein the showings are for the purpose of illustrating a preferred embodiment of the invention only, and not for purpose of limiting the same, FIG. 1 illustrates a chemical dispenser generally designated at 10 having a gas generator apparatus 12 and liquid dispenser apparatus 14. The chemical dispenser 10

includes horizontal support base 16 having a generally, but not limited to, rectangular configuration with an upper surface 18 for supporting the liquid dispenser apparatus 14 as well as supporting the chemical dispenser 10 on the ground or a support surface. The chemical dispenser 10 further includes a vertical support stand 20 having a generally, but not limited to, rectangular configuration for supporting the gas generator apparatus 12 in a manner which will be explained in greater detail herein. The vertical support stand 20 includes a first end 22 and a second end 24, wherein the second end 24 is secured to the upper surface 18 of the horizontal support base 16 by securing means such as, but not limited to, welding or screws.

[0012] The gas generator apparatus 12 is described in the U.S. Pat. No. 4,563,286, to Johnson et al., the disclosure of which is incorporated herein in its entirety.

[0013] Broadly, the gas generator apparatus 12 includes a substantially cylindrical body 26 having a length of, but not limited to, 36 inches. The gas generator apparatus 12 further includes an ultraviolet lamp 28 configured and dimensioned to be disposed inside the cylindrical body 26. The cylindrical body 16 is closed off with an upper cap portion 30 and a lower cap portion 32 removably secured to the top and bottom openings of the cylindrical body 16 respectively. The upper cap portion 30 includes an air intake opening 34 having an air filter 36 disposed thereon. The ultraviolet lamp 28 is powered by a power supply and a balast transformer 38 connected to the ultraviolet lamp 28 by an electrical cord 40 through the upper cap portion 30.

[0014] The gas generator apparatus 12 further includes a plurality of support plates 42 welded to the outer surface of the cylindrical body 26, wherein each support plate 42 includes a flange portion 44 that is dimensioned and configured to be removably received in corresponding flange-receiving apertures 46 on a front surface 48 of the vertical support stand 20 to removably secure the cylindrical body 26 on the vertical support stand 20. The support plates 42 are dimensioned so that they can extend beyond the outer surface of the cylindrical body 26 thereby creating a space between the cylindrical body 26 and the front surface 48 of the vertical support stand 20 once mounted. The balast transformer 38 is also removably secured on the front surface 48 of the vertical support stand 20 and is disposed in the space between the cylindrical body 26 and the front surface 48.

[0015] Referring now to FIGS. 1 and 4, the gas generator apparatus 12 further includes an enclosure 50 that encloses various components for operating the gas generator apparatus 12. The enclosure 50 is removably secured to the front surface 48 of the vertical support stand 20 below the cylindrical body 26 and includes a front opening 52 that provides access inside the enclosure 50. The enclosure 50 also includes a cover 54 removably secured with a plurality of screws 56 to close off the opening 52.

[0016] The gas generator apparatus 12 further includes a pump means, such as, but not limited to, a diaphragm pump 58 disposed inside the enclosure 50. The diaphragm pump 58 includes an air inlet 60 and an air outlet 62. A first tube 64 is connected to the air inlet 60 at one end, and is connected to a first nipple 66 disposed on the inside upper wall of the enclosure 50 at an opposing second end. A second nipple 68 is disposed on the outer surface of the upper wall

and is in communication with the first nipple 66. A second tube 72 includes a first end connected the second nipple 68 and a second end connected to a third nipple 70 disposed on the lower cap portion 32. Therefore, the air inlet 60 of the diaphragm pump 58 provides for the suction of the ionized air from the cylindrical body 26 through second tube 72 and the first tube 64.

[0017] A third tube 76 includes a first end connected the outlet 62 of the diaphragm pump 58, and second end connected to a fourth nipple 74 disposed on the lower wall of the enclosure 50. A fifth nipple 78 is disposed on the outer surface of the lower wall of the enclosure 50 and is in communication with the fourth nipple 74. A fourth tube 80 is connected to the fifth nipple 78 at one end and extends to connect to the bottom of the wash cycle with a sparging rod (not shown) at the second opposing end. The gas generator apparatus 12 and the diaphragm pump 58 are operated by an electronic control means 82, and electrical power is provided by a power cord 84 connected to a suitable power outlet 168.

[0018] Referring now to FIGS. 1, 2, and 3, the liquid dispenser apparatus 14 will now be described in greater detail. The liquid dispenser apparatus 14 includes a platform 86 for supporting various components of the liquid dispenser apparatus thereon. The platform 86 is preferably circular and is configured and dimensioned to sit on top a conventional five gallon pail 88 containing the liquid or laundry detergent needed to be dispensed. It should be appreciated that any other type of liquid containers may be contemplated to be used, however, it noted that most commercial laundry detergents are sold in conventional five gallon pails and therefore it is simply easier and more convenient to replace the pail once the detergent is finished.

[0019] The five gallon pail 88 includes an upper periphery 90 bounding an opening 92 which provides access inside the pail 88. The platform 86 includes an upper surface 94 and a lower surface 96. An annular indentation 98 is formed on the lower surface 96 of the platform 86 wherein the upper periphery 90 of the pail 88 is received within the annular indentation 98 once the platform 86 is placed on top of the pail 88.

[0020] Furthermore, the platform 86 includes an opening 100 which extends from the upper surface 94 to the lower surface 96 and is configured and dimensioned to receive an outer pipe 102 such as, but not limited to, a PVC pipe. The PVC pipe 102 includes an upper Y-shaped portion 104 that extend upwardly from the upper surface 94, and a lower elongated portion 110 that extends downwardly from the lower surface 96 of the platform 86. The Y-shaped portion 104 further includes a first branch 106 and a second branch 108. The lower elongated portion 110 of the PVC pipe 102 has a cut-out portion 112 at its end and sits substantially close to the bottom of the pail 88.

[0021] An inner pipe 114 having a smaller diameter but substantially the same length as the PVC pipe 102 is concentrically disposed inside the PVC pipe 102. The inner concentric pipe 114 extends through the first branch 106 of the Y-shaped portion 104 is connected to a first fitting 150. As will be explained in greater detail herein, the inner pipe 114 is used to deliver the liquid inside the pail 88 to the washing machine, and the space 116 between the outer surface of the inner pipe 114 and the inner surface of the PVC pipe 102 is used to determine the liquid level inside the

pail using a pressure switch operably connected through the second branch 108 of the Y-shaped portion 104.

[0022] The liquid dispenser apparatus 14 further includes an enclosure 118 having an opening 120 on top providing access inside the enclosure 118 which, as will be explained, houses a number of operating components for the liquid dispenser apparatus 14. The enclosure 118 includes a plurality of flanges 122 extending outwardly at the bottom of its sides wherein each flange 122 includes an opening 124 for receiving a screw 126 to secure the enclosure 118 on the upper surface 94 of the platform 86. A lid or cover 128 having a handle portion 130 is provided to close the opening 120 of the enclosure 118 and is secured on top of the enclosure 118 with a plurality of securing means such as, but not limited to, screws 132.

[0023] The liquid dispenser apparatus 14 further includes a pump means such as, but not limited to, a peristaltic pump 134 secured on a sidewall 136 of the enclosure 118. The peristaltic pump 134 is operated by a motor means 138 having a cooling fan 140 disposed inside the enclosure 118.

[0024] The peristaltic pump 134 includes an inlet tube 142 and an outlet tube 144. A fifth tube 146 is connected to the inlet tube 142 of the peristaltic pump 134 at one end by a nipple 148, and is connected to the first branch 106 of the Y-shaped portion 104 by the first fitting 150 at the other end. As stated hereinabove, the first fitting 150 is also connected to the inner pipe 114 and also includes a check valve (not shown). Therefore, with this arrangement, the liquid inside the pail is delivered to the peristaltic pump 134 through the inner pipe 114, fifth tube 146, and into the inlet tube 142. The outlet tube 144 is connected to an external hose 152 with a second fitting 154 wherein the external hose's free end is connected to the liquid detergent inlet of the washing machine at the installation site by a technician.

[0025] The liquid dispenser apparatus 14 further includes a pressure measuring device and electronics 156 disposed inside the enclosure 118. The pressure measuring device 156 is used to alert an operator, either visually or audibly, when the liquid inside the pail is within five percent of empty. A tube 158 is connected to the pressure measuring device 156 with a third fitting 160 at one end, and is connected to the second branch 108 of the Y-shaped portion 104 by a fourth fitting 162. The pressure measuring device 156 measures the pressure of the air in the space 116 between the outer surface of the inner pipe 114 and the inner surface of the PVC pipe 102 as the liquid rises or fall inside the PVC pipe 102.

[0026] Electrical power is provided to the liquid dispenser apparatus 14 and the peristaltic pump 134 by a power cord 164 connected to the apparatus through a standard receptacle plug 166 disposed on the side of the enclosure 118 at one end, and connected to suitable power outlet 168 at the opposing end.

[0027] The liquid dispenser apparatus 14 further includes an operating switch 170 which allows the liquid dispenser apparatus to operate either in an automatic mode or in a manual mode. When the switch is set in the manual mode, the liquid dispenser apparatus continuously operates to dispense liquid. However, when the switch 170 is set in the automatic mode, the liquid dispenser apparatus then operates by command signals received from the washing machine which is connected to the apparatus through a

socket. The washing machine can signal the liquid dispenser apparatus 14 to dispense liquid at appropriate times and intervals. The liquid dispenser apparatus 14 also includes an LED or other light means 172 which indicates whether the apparatus is turned on or off.

[0028] In operation, the liquid dispenser apparatus 14 and the gas generator apparatus 12 may operate independently from one another or may be operate simultaneously.

[0029] While preferred embodiments have been shown and described, various modifications and substitutions may be made thereto without departing from the spirit and scope of the invention. Accordingly, it is to be understood that the present invention has been described by way of illustration only, and such illustrations and embodiments as have been disclosed herein are not to construed as limiting to the invention as defined by the several claims appended hereto.

- 1. A chemical dispenser, comprising:
 - a gas generator;
 - a liquid dispenser;
 - a support stand, wherein said gas generator is removably mounted on said support stand;
 - a support base, wherein said liquid dispenser is removably mounted on said support base; and,
 - said support stand is attached to said support base.
- 2. The chemical dispenser of claim 1, wherein said liquid dispenser further comprises a support platform adapted to rest on a liquid container.
- 3. The chemical dispenser of claim 2, wherein said liquid dispenser further comprises a pump means secured on said support platform and having an inlet and an outlet.
- 4. The chemical dispenser fo claim 3, wherein said pump means is a peristaltic pump.
- 5. The chemical dispenser of claim 4, wherein said support platform includes a, pipe receiving opening, an outer pipe having a Y-shaped portion and an elongated portion disposed through said pipe receiving opening and extending substantially the height of said container.
- 6. The chemical dispenser of claim 5, wherein said Y-shaped portion further comprises a first branch having an outlet and a second branch having an outlet, an inner pipe

concentrically disposed within said outer pipe wherein a space is created between an outer surface of said inner pipe and an inner surface of said outer pipe, and where said inner pipe is in communication with said first branch outlet and in fluid communication with said pump means inlet.

7. The chemical dispenser of claim 6, further comprising a pressure measuring device wherein said second branch outlet is in communication with said pressure measuring device, said pressure measuring device measuring the pressure of the air in the space between the outer surface of the inner pipe and the inner surface of the outer pipe.

8. The chemical dispenser of claim 7, wherein said pressure measuring device further comprises an alert means to notify an operator audibly or visually of the liquid level inside said container.

9. The chemical dispenser of claim 8, wherein said liquid dispenser further comprises a pump operating means wherein said pump operating means controls said pump means in a manual or automatic mode.

10. The chemical dispenser of claim 9, wherein said liquid dispenser further comprises a control means connected to a washing machine allowing the washing machine to control said pump means when said pump operating means is set in the automatic mode.

11. The chemical dispenser of claim 2, wherein said liquid container is a five gallon pail.

12. The chemical dispenser of claim 5, wherein said outer pipe is a PVC pipe.

13. The chemical dispenser of claim 1, wherein said gas generator comprises a cylindrical body having an air inlet and an air outlet, wherein said cylindrical body is removable secured on said support stand.

14. The chemical dispenser of claim 13, wherein said gas generator includes an ultraviolet lamp disposed inside said cylindrical body and a balast.

15. The chemical dispenser of claim 14, wherein said gas generator further comprises a pump means having an air inlet and an air outlet, said air inlet is connected to said air outlet of said cylindrical body, and said pump means air outlet is connected to a disparging rod.

16. The chemical dispenser of claim 15, wherein said pump means is a diaphragm pump.

* * * * *