

(19) World Intellectual Property Organization
International Bureau



(43) International Publication Date
3 July 2008 (03.07.2008)

PCT

(10) International Publication Number
WO 2008/079902 A1

(51) International Patent Classification:
G08B 13/14 (2006.01)

(74) Agent: GILLESPIE, Noel, C.; Baker & McKenzie LLP,
2001 Ross Avenue, Suite 2300, Dallas, TX 75201 (US).

(21) International Application Number:
PCT/US2007/088227

(81) Designated States (unless otherwise indicated, for every kind of national protection available): AE, AG, AL, AM, AT, AU, AZ, BA, BB, BG, BH, BR, BW, BY, BZ, CA, CH, CN, CO, CR, CU, CZ, DE, DK, DM, DO, DZ, EC, EE, EG, ES, FI, GB, GD, GE, GH, GM, GT, HN, HR, HU, ID, IL, IN, IS, JP, KE, KG, KM, KN, KP, KR, KZ, LA, LC, LK, LR, LS, LT, LU, LY, MA, MD, ME, MG, MK, MN, MW, MX, MY, MZ, NA, NG, NI, NO, NZ, OM, PG, PH, PL, PT, RO, RS, RU, SC, SD, SE, SG, SK, SL, SM, SV, SY, TJ, TM, TN, TR, TT, TZ, UA, UG, US, UZ, VC, VN, ZA, ZM, ZW.

(22) International Filing Date:
19 December 2007 (19.12.2007)

(25) Filing Language: English

(26) Publication Language: English

(30) Priority Data:
60/871,273 21 December 2006 (21.12.2006) US

(84) Designated States (unless otherwise indicated, for every kind of regional protection available): ARIPO (BW, GH, GM, KE, LS, MW, MZ, NA, SD, SL, SZ, TZ, UG, ZM, ZW), Eurasian (AM, AZ, BY, KG, KZ, MD, RU, TJ, TM), European (AT, BE, BG, CH, CY, CZ, DE, DK, EE, ES, FI, FR, GB, GR, HU, IE, IS, IT, LT, LU, LV, MC, MT, NL, PL, PT, RO, SE, SI, SK, TR), OAPI (BF, BJ, CF, CG, CI, CM, GA, GN, GQ, GW, ML, MR, NE, SN, TD, TG).

(71) Applicant (for all designated States except US): NEOL-
OGY, INC. [US/US]; 13000 Gregg Street, Suite A, Poway,
CA 92064 (US).

(72) Inventors; and

(75) Inventors/Applicants (for US only): ZHU, Jeffrey
[CA/US]; 1019 Sagebrush Road, Carlsbad, CA 92011
(US). YEN, Chih-chuan [—/US]; 8582 Summerdale
Rd., Unit 157, San Diego, CA 92126 (US). LIU, Jason
[CA/US]; 12290 Corte Sabio, Unit 3206, San Diego, CA
92128 (US). MULLIS, Joe [US/US]; 2210 Luz Way,
Oceanside, CA 92056 (US).

Published:
— with international search report
— before the expiration of the time limit for amending the claims and to be republished in the event of receipt of amendments

(54) Title: SYSTEMS AND METHODS FOR A RFID ENABLED METAL LICENSE PLATE

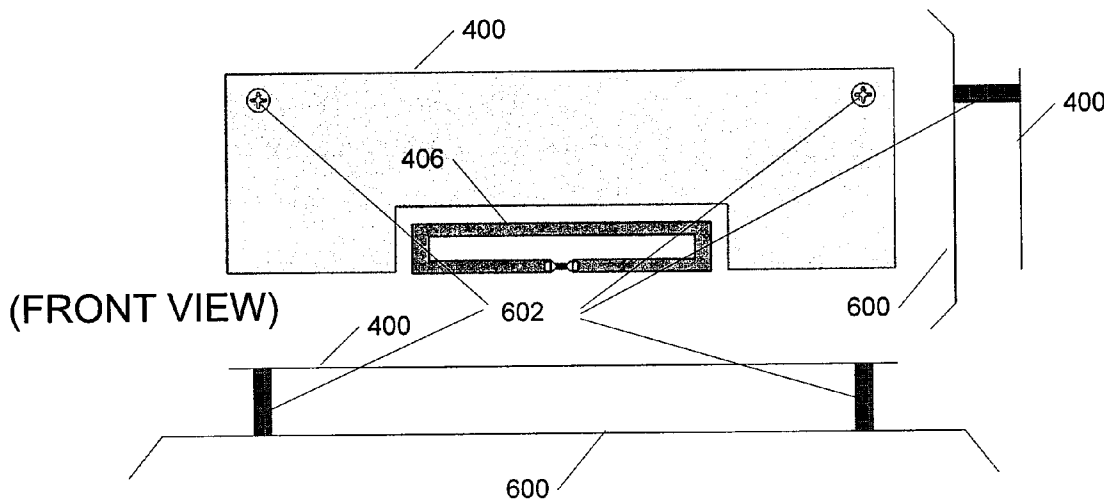

(57) Abstract: In the embodiments described herein, a RFID enabled license plate is constructed by using the license plate, or a retro-reflective layer formed thereon as part of the resonator configured to transmit signals generated by an RFID chip integrated with the license plate. Such an RFID enabled license plate can include a metal license plate with a slot formed in the metal license plate, and a RFID tag module positioned in the slot. The RFID tag module can include a chip and a loop, and the loop can be coupled with the metal license plate, e.g., via inductive or conductive coupling. In this manner, the metal license plate can be configured to act as a resonator providing increased performance.

WO 2008/079902 A1

S P E C I F I C A T I O N

SYSTEMS AND METHODS FOR A RFID ENABLED METAL LICENSE
PLATE

RELATED APPLICATIONS INFORMATION

[0001] This application claims the benefit under 35 U.S.C. 119 (e) to U.S. Provisional Patent Application Ser. No. 60/871,273, filed December 21, 2006, and entitled "Method and Apparatus for RFID Enabled Metal License Plates", which is incorporated herein by reference in its entirety as if set forth in full.

BACKGROUND

1. Field of the Invention

[0002] The embodiments described herein relate generally to electronic vehicle registration and tracking systems, and more particularly to the use of Radio Frequency Identification (RFID) in such systems.

2. Background of the Invention

[0003] RFID technology has long been used for electronic vehicle tolling applications. In such applications, an RFID reader or interrogator is positioned over or near a road way at a point where a toll is to be collected. An RFID tag is then placed in each vehicle that includes an identifier by which the vehicle can be recognized, e.g., the vehicle's license plate number. The interrogator

then uses RF signals to interrogate the tag and obtain the identifier so that the toll can be applied to the correct vehicle, or account.

[0004] Generally, the tag to interrogator communication is achieved through a form of modulation known as backscatter modulation. In a backscatter modulation system, the tag does not generate its own RF carrier signal when transmitting information to the interrogator. Rather, the interrogator generates an RF carrier and modulates the carrier with data intended for the tag, e.g., a request for the tags identifier information. The tag receives the modulated signal decodes the data and then performs actions in accordance therewith e.g., accesses the memory and obtains the requested identifier information. The interrogator continues to transmit the RF carrier, now with no data on it. The tag receives this un-modulated carrier and reflects it back to the interrogator. This is called backscatter. In order to send data back to the interrogator, e.g., identifier, the tag modulates the reflected, or backscatter signal with the data.

[0005] For example, the tag will alternately backscatter and not backscatter the RF carrier signal for a certain period of time in order to transmit a digital "0" an "1" respectively. Thus, the tag modulates the backscatter signal by reflecting or not reflecting the signal based on the data, i.e., "1s" and "0s," to be sent. The interrogator receives the modulated backscatter signal and decodes the information received thereon.

[0006] Early on, such tags were active device, meaning they possessed their own power source, such as a battery. An active tag was necessary, for example, in order to generate enough power in the reflected signal to transmit information over extended distances. But more recently, passive tag technology has become more viable. A passive tag does not include a battery or power source of its own. Rather, energy in the RF signals received from the interrogator is used to power up the tag. For example, the received RF signal can be rectified and used to charge up a capacitor that is then used to power the tag.

[0007] As antenna and integrated circuit technology has evolved, larger and larger distances can be achieved with passive tags of smaller and smaller dimensions. Accordingly, small, thin, light weight tags can be used in a wide variety of applications. Often these tags are referred to as sticker tags or RFID labels, because of their dimensions and the fact that they can be manufactured to include an adhesive layer so that they can be applied to the outside of containers, the surface of documents, inventory, etc. In other words the tags can be applied like a label or sticker.

[0008] The emergence of passive, sticker tag technology has also greatly reduced the cost of implementing an RFID system. As a result, new applications, such as Electronic Vehicle Registration (EVR) using RFID, have emerged. Currently, e.g., in the United States, a vehicle owner registers their vehicle with the State government and pays a fee. The owner is then provider a

sticker, which is applied to the vehicle license plate, to evidence the valid registration of the vehicle; however, these stickers can easily be counterfeited or stolen, i.e., removed and applied to another vehicle. Such activity is difficult to detect, because the only way to determine that a registration sticker does not belong on a certain vehicle is to access a database and check the corresponding information.

[0009] For example, in the United States, an estimated five to ten percent of motorists fail to legally register their vehicles, resulting in lost annual state revenues of between \$720 million and \$1.44 billion. Outside of the United States, some government agencies report the problem at 30-40% of the vehicles.

[0010] Deploying an Electronic Vehicle Registration system can help Motor Vehicle Administrators achieve increases in vehicle compliance and associated revenues by eliminating the need to rely on inefficient, manual, visual-based compliance monitoring techniques. EVR uses RFID technology to electronically identify vehicles and validate identity, status, and authenticity of vehicle data through the use of interrogators and tags that include data written into the tag memory that matches the vehicle registration data. Fixed, e.g., roadside, or handheld interrogators can then be used to read the data out when required. Thus, RFID technology can enable automated monitoring of

vehicle compliance with all roadway usage regulations, e.g., vehicle registration, tolling, etc., through a single tag.

[0011] There are two common ways of attaching a RFID tag to a vehicle, one is using an RFID label tag attached to the windshield of the vehicle. The tag can then be read by a roadside or handheld reader. A second method of attaching the tag to a vehicle is to embed the RFID tag into the license plate. This has the convenience and continuity of replicating the application of current registration stickers; however, such a solution can also suffer from reduced transmission, i.e., communication distance due to the effects the metal license plate has on the performance of the tag antenna.

[0012] For example, as illustrate in figure 1, a RFID tag 100 consisting of a RFID chip 102 and an antenna 104 can be mounted on the vehicle license plate 110. As mentioned, however, license plate 110 is usually made from metal. As a result, the tag information may not be readable due to the shielding effects of metal surrounding tag 100. Moreover, if tag 100 is directly applied to the metal surface of license plate 110, then tag antenna 104 can be shorted or severely detuned by the metal surface. As a result, tag 100 will not be read, or will only be readable at very short distance.

[0013] A conventional approach to overcoming this issue is to leave some spacing 202 between tag 100 and metal license plate 110 as shown in Figure 2. Such a solution has an added benefit in that metal license plate 110 can

also serve as a back plane for tag antenna 104. For example, as illustrated in figure 3, an RFID tag 100 can be housed within a non-metal enclosure 302, e.g., formed from a low dielectric material that includes a spacer 304 such as an air gap or foam material.

[0014] One problem with such a conventional solution is the increased dimension, i.e., thickness of the resulting license plate assembly. Accordingly, conventional approaches force a tradeoff between reduced performance, or increased size and dimensions, which can have a negative impact.

SUMMARY

[0015] In the embodiments described herein, a RFID enabled license plate is constructed by using the license plate, or a retro-reflective layer formed thereon as part of the resonator configured to transmit signals generated by an RFID chip integrated with the license plate.

[0016] For example, in one aspect, such an RFID enabled license plate can include a metal license plate with a slot formed in the metal license plate, and an RFID tag module positioned in the slot. The RFID tag module can include a chip and a loop, and the loop can be coupled with the metal license plate, e.g.,

via inductive or conductive coupling. In this manner, the metal license plate can be configured to act as a resonator providing increased performance.

[0017] In another aspect, the RFID tag module can be positioned substantially within the slot such that the addition of the RFID tag module does not increase the thickness of the license plate.

[0018] In still another aspect, the RFID enabled license plate can comprise a RFID tag module, positioned in the slot, which includes a chip and contacts. The contacts connected with the metal license plate, e.g., via a conductive paste or a solder connection.

[0019] In still another aspect, the RFID enabled license plate can comprise a license plate and a retro-reflective layer formed over the license plate. A slot can then be formed in the retro-reflective layer, and a RFID tag module can be positioned in the slot. The RFID tag module can include a chip and a loop, and the loop coupled with the retro-reflective layer, e.g., via inductive or conductive coupling.

[0020] In still another aspect, the RFID enabled license plate can include a retro-reflective layer formed over the license plate and a slot formed in the metal license plate. A RFID tag module can be positioned in the slot. The RFID tag module can comprise a chip and contacts, and the contacts connected with the metal license plate, e.g., via a conductive paste or a solder connection.

[0021] These and other features, aspects, and embodiments of the invention are described below in the section entitled "Detailed Description."

BRIEF DESCRIPTION OF THE DRAWINGS

[0022] Features, aspects, and embodiments of the inventions are described in conjunction with the attached drawings, in which:

[0023] Figure 1 is a diagram illustrating an exemplary license plate comprising an RFID module;

[0024] Figure 2 is a diagram illustrating a side view of the license plate of figure 1;

[0025] Figure 3 is a diagram illustrating a RFID module that can be used in conjunction with the license plate of figures 1 and 2;

[0026] Figures 4A and 4B are diagrams illustrating an example RFID enabled license plate in accordance with one embodiment;

[0027] Figures 5A and 5B are diagrams illustrating methods for coupling an RFID module with the license plate of figures 4A and 4B;

[0028] Figures 6A-C are diagrams illustrating an example RFID enabled license plate in accordance with another embodiment;

[0029] Figures 7A-C are diagrams illustrating example RFID enabled license plate in accordance with another embodiment;

[0030] Figure 8 is a diagram illustrating another example RFID enabled license plate in accordance with another embodiment; and

[0031] Figure 9 is a diagram illustrating another example RFID enabled license plate in accordance with another embodiment.

DETAILED DESCRIPTION

[0032] The embodiments described below are directed to system and methods for a RFID enabled license plate in which a metal layer of the license plate is actually used to radiate backscattered energy generated by a RFID tag positioned within a slot created in the license plate. Accordingly, not only does the metal license plate not interfere with the operation of the tag, it actually assists.

[0033] Certain embodiments described herein are directed to methods for creating an antenna structure directly on (1) a metal license plate, (2) a metalized retro-reflective foil covering a non-metal license plate, or (3) a metalized retro-reflective foil covering the metal license plate. Depending on the embodiment, the RFID chip can be directly connected to or electrically coupled, either capacitive or inductively, with the antenna structure. The antenna structure can be a single or multi-frequency resonant structure.

[0034] Figure 4, comprising figures 4A and 4B, is a diagram illustrating an example license plate 400 comprising an RFID tag in accordance with one embodiment. As shown in figure 4A, license plate 400 can comprise an open area, or slot 402. For example, slot 402 can be cut into metal license plate 400. Alternatively, slot 402 can be punched out of plate 400. As shown in

figure 4B, a RFID tag module 406 comprising an enclosure around tag 404 can then be positioned within slot 402. The dimensions of slot 402 and module 406 can be designed such that module 406 fits within slot 402 creating a substantially planar surface with the surface of metal license plate 400. It should be noted that the top of module 406 is shown extending beyond the surface of license plate 400 in figure 4B, creating a non-planar surface; however, this is purely for illustration. In practice, module 406 can be made extremely thin allowing for a substantially planar surface across all of plate 400, including slot 402, even when module 406 is installed therein.

[0035] For example, module 406 can be similar to the module illustrated in figure 3. Thus, module 406 can include an enclosure if required. Module 406 can then be configured to include a feeding loop that can couple tag 404 with metal license plate 400. In this manner, the entire license plate 400 can then serve as an effective radiator via inductive coupling through the feeding loop.

[0036] Figures 5A and 5B illustrate two example implementations of the embodiment illustrated in figure 4. In figure 5A, module 406 comprises a chip 502 coupled with a feeding loop 504. Slot 402 is then positioned such that feeding loop 504 will be inductively coupled with metal license plate 400. In figure 5B, slot 403 is positioned such that feeding loop 504 is capacitively coupled with metal license plate 400.

[0037] Further, in certain embodiments, the radiation gain can be enhanced by using the metallic car frame (not shown). For example, with a properly designed tag antenna and proper consideration of the spacing between the metallic car frame and license plate 400, the metal car frame can be used as a good antenna reflector.

[0038] In another embodiment, a structure very similar to Planar Inverted-F Antenna (PIFA) can be implemented by screwing the license plate directly to the metallic car frame as illustrated in Figure 6. In figure 6, which comprises figures 6A-C, metallic screws serve as shorting posts 602 and metallic car frame 600 serves as a ground plane for the antenna of tag module 406.

[0039] Figure 7, comprising figures 7A, 7B, and 7C, is a diagram illustrating an example of a license plate 700 configured to incorporate an RFID tag in accordance with another embodiment. As shown in figure 7A, an area, or slot 702 is cut, or punched, etc., in license plate 700. As shown in figure 7B, a non-metal material 704 can then be inserted into slot 702 such that both the front and rear surfaces of license plate 700 are flat. Material 704 can be stuffed, extruded, etc., into slot 702. As shown in figure 7C, an RFID "strap" comprising a chip 708 with contacts 710 can then be positioned over slot 702 as illustrated. Contacts 710 can then be connected to or capacitively coupled with metal license plate 700. Depending on the embodiment, strap 712 can be placed on either the front surface or the rear surface of the license plate. The

entire license plate 700 then becomes a slot antenna coupled with the RFID chip, which is less sensitive to the metallic car frame in terms of tag antenna detuning effect. Contacts 710 can be soldered to plate 700, adhered using a conductive paste, or both.

[0040] It should also be noted that strap 712 can be made extremely thin, such that the surface of license plate 700 is substantially planar.

[0041] In certain embodiments, the dimensions of slot 702 can be altered, or multiple slots included to create a dual or multiple resonance frequency slot antenna. In such configurations, the tag will respond to multiple frequency bands, such as the Ultra High frequency (UHF) band, e.g., 900MHz, and the microwave band, e.g. 2.45GHz. This can allow multiple application capability. For example, depending on the application, one frequency band can be preferred for its localization characteristics and another frequency band can be preferred for its long range read capabilities. More specifically, a higher frequency band, such as a 2.45 GHz band, can be used for write applications as its limited range helps insure only the tag of interest is written to, while a lower frequency band, such as a 900 MHz band, can be used for multi-tag read applications as its greater range allows many tags to be read over a large area. In other embodiments, multiple frequency bands can be needed due to regulatory requirements that can vary the authorized frequency band based on locations, e.g., country, city, etc., and by application.

[0042] Figures 8 and 9 are diagrams illustrating example multi-frequency RFID license plates in accordance with two example embodiments. In figure 8, two slots 802 and 804 are formed in metal license plate 800. A strap 806 is then positioned across slot 806 as illustrated. The two slots 802 and 804 are configured, with respect to dimensions, spacing, location, etc., such that the slot antenna formed from license plate 800, slots 802 and 804 and strap 806 will resonate at the desired frequencies, e.g., the UHF and microwave bands.

[0043] In figure 9, two slots 902 and 904 are formed in license plate 900; however, in this example, slots 902 and 904 are connected via slot 906. A slot 910 then extends to the edge of plate 900. Strap 908 is then positioned across slot 910 as illustrated. Again, slots 902, 904, 906, and 910 are configured such that the resulting slot antenna resonates at the desired frequencies.

[0044] The slots of figures 8 and 9 can be filled with non-metallic material as in the example of figure 7 depending on the embodiment. Further, certain parasitic elements can be included, or changed to achieve the proper multi-frequency operation. It should also be noted that the embodiments of figures 4 and 5 can also be configured as multi-frequency resonant structures via the inclusion of further slots appropriately constructed so as to allow the structure to resonate at the desired frequencies.

[0045] It will be understood that other slot dimensions, locations, spacing, interconnectedness, etc., are possible and will depend on the requirements of a

particular implementation. Similarly, the position of the strap comprising the chip and connectors can vary as required by a particular implementation. Accordingly, the specific implementations illustrated herein should not be seen as limiting the embodiments disclosed to any particular configuration.

[0046] It will also be understood that the impedance of the resulting antenna structure in the above embodiments will need to be matched to that of the chip. This can impact the slot dimensions, etc. It can also require additional circuit elements, i.e., the inclusion of a matching circuit.

[0047] A retro-reflective film can be used to cover the front surface of the license plate. Such a film can make the license plate modification invisible from front view; and can also makes the license plate viewable in dark lighting. If the retro-reflective film contains metal materials, e.g., a metallized polymer film, then a selective metal removal process can be applied such that the film area covering the open area in the license plate is de-metallized. Such a de-metallization is described in detail in co-owned U.S. patent 7,034,688, as well as Co-owned patent application Ser. No. 10/485,863, each of which are incorporated herein by reference as if set forth in full. In other embodiments, the antenna structure can actually be formed on a retro-reflective layer that is then applied to a non-metallic, or metallic, license plate.

[0048] While certain embodiments of the inventions have been described above, it will be understood that the embodiments described are by way of example

only. Accordingly, the inventions should not be limited based on the described embodiments. Rather, the scope of the inventions described herein should only be limited in light of the claims that follow when taken in conjunction with the above description and accompanying drawings.

What is claimed is:

1. A RFID enabled license plate, comprising:
a metal license plate;
a slot formed in the metal license plate; and
a RFID tag module positioned in the slot, the RFID tag module comprising a chip and a loop, the loop coupled with the metal license plate.
2. The RFID enabled license plate of claim 1, wherein the loop is coupled with the metal license plate via inductive coupling.
3. The RFID enabled license plate of claim 1, wherein the loop is coupled with the metal license plate via capacitive coupling.
4. The RFID enabled license plate of claim 1, where the RFID tag module comprises an enclosure.
5. The RFID enabled license plate of claim 4, wherein the enclosure is made from a non-metallic material.
6. The RFID enabled license plate of claim 4, wherein the enclosure includes an air gap.
7. The RFID enabled license plate of claim 4, wherein the RFID tag module further comprises a spacer within the enclosure.

8. The RFID enabled license plate of claim 7, wherein the spacer is made from a dielectric material.
9. The RFID enabled license plate of claim 1, further comprising a plurality of slots formed in the metal license plate, wherein each slot is configured to resonate at a different frequency, and wherein the RFID tag module is positioned within one of the plurality of slots.
10. The RFID enabled license plate of claim 1, further comprising a retro-reflective layer over the metal license plate.
11. The RFID enabled license plate of claim 10, wherein the retro-reflective layer comprises metal material, and wherein a portion of the retro-reflective layer is selectively removed so as not to interfere with the operation of the RFID tag module.
12. The RFID enabled license plate of claim 1, further comprising posts configured to connect the license plate to a vehicle, wherein the posts short the metal license plate to the vehicle such that the vehicle acts as a ground plane.
13. A RFID enabled license plate, comprising:
 - a metal license plate;
 - a slot formed in the metal license plate; and

a RFID tag module positioned in the slot, the RFID tag module comprising a chip and contacts, the contacts connected with the metal license plate.

14. The RFID enabled license plate of claim 13, wherein the contacts are connected with the metal license plate via conductive paste.

15. The RFID enabled license plate of claim 13, wherein the are electrically connected with the metal license plate via a solder connection.

16. The RFID enabled license plate of claim 13, where the RFID tag module comprises an enclosure.

17. The RFID enabled license plate of claim 13, wherein the enclosure is made from a non-metallic material.

18. The RFID enabled license plate of claim 13, wherein the enclosure includes an air gap.

19. The RFID enabled license plate of claim 13, wherein the RFID tag module further comprises a spacer within the enclosure.

20. The RFID enabled license plate of claim 19, wherein the spacer is made from a dielectric material.

21. The RFID enabled license plate of claim 13, further comprising a plurality of slots formed in the metal license plate, wherein each slot is configured to resonate at a different frequency, and wherein the RFID tag module is positioned within one of the plurality of slots.

22. The RFID enabled license plate of claim 13, further comprising a retro-reflective layer over the metal license plate.

23. The RFID enabled license plate of claim 22, wherein the retro-reflective layer comprises metal material, and wherein a portion of the retro-reflective layer is selectively removed so as not to interfere with the operation of the RFID tag module.

24. The RFID enabled license plate of claim 13, further comprising posts configured to connect the license plate to a vehicle, wherein the posts short the metal license plate to the vehicle such that the vehicle acts as a ground plane.

25. A RFID enabled license plate, comprising:
a license plate;
a retro-reflective layer formed over the license plate;
a slot formed in the retro-reflective layer; and

a RFID tag module positioned in the slot, the RFID tag module comprising a chip and a loop, the loop coupled with the retro-reflective layer.

26. The RFID enabled license plate of claim 25, wherein the loop is coupled with the retro-reflective layer via inductive coupling.

27. The RFID enabled license plate of claim 25, wherein the loop is coupled with the retro-reflective layer via capacitive coupling.

28. The RFID enabled license plate of claim 25, where the RFID tag module comprises an enclosure.

29. The RFID enabled license plate of claim 28, wherein the enclosure is made from a non-metallic material.

30. The RFID enabled license plate of claim 28, wherein the enclosure includes an air gap.

31. The RFID enabled license plate of claim 28, wherein the RFID tag module further comprises a spacer within the enclosure.

32. The RFID enabled license plate of claim 31, wherein the spacer is made from a dielectric material.

33. The RFID enabled license plate of claim 25, further comprising a plurality of slots formed in the retro-reflective layer, wherein each slot is configured to resonate at a different frequency, and wherein the RFID tag module is positioned within one of the plurality of slots.

34. The RFID enabled license plate of claim 25, wherein the license plate is a metal license plate.

35. A RFID enabled license plate, comprising:
a license plate;
a retro-reflective layer formed over the license plate;
a slot formed in the metal license plate; and
a RFID tag module positioned in the slot, the RFID tag module comprising a chip and contacts, the contacts connected with the metal license plate.

36. The RFID enabled license plate of claim 35, wherein the contacts are connected with the retro-reflective layer via conductive paste.

37. The RFID enabled license plate of claim 35, wherein the are electrically connected with the retro-reflective layer via a solder connection.

38. The RFID enabled license plate of claim 35, where the RFID tag module comprises an enclosure.
39. The RFID enabled license plate of claim 35, wherein the enclosure is made from a non-metallic material.
40. The RFID enabled license plate of claim 35, wherein the enclosure includes an air gap.
41. The RFID enabled license plate of claim 35, wherein the RFID tag module further comprises a spacer within the enclosure.
42. The RFID enabled license plate of claim 41, wherein the spacer is made from a dielectric material.
43. The RFID enabled license plate of claim 35, further comprising a plurality of slots formed in the retro-reflective layer, wherein each slot is configured to resonate at a different frequency, and wherein the RFID tag module is positioned within one of the plurality of slots.
44. The RFID enabled license plate of claim 35, wherein the license plate is a metal license plate.

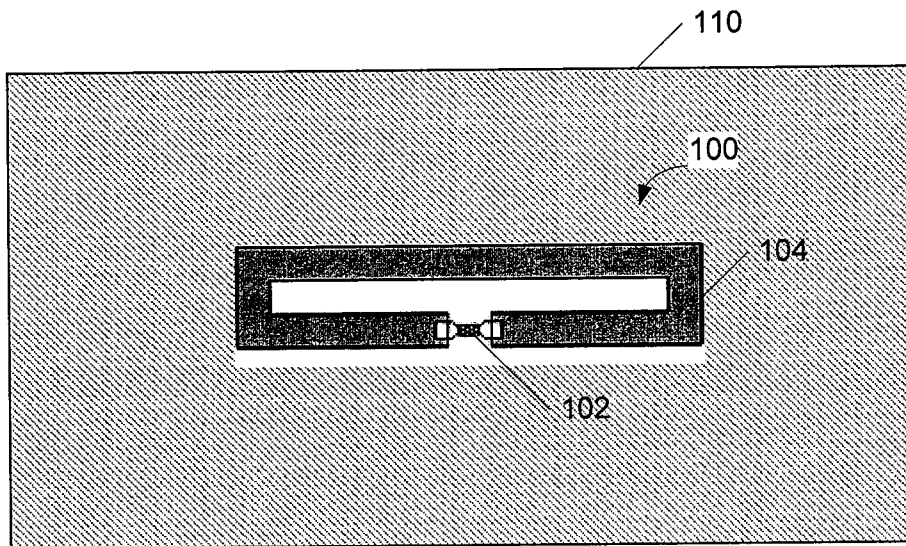

FIG. 1

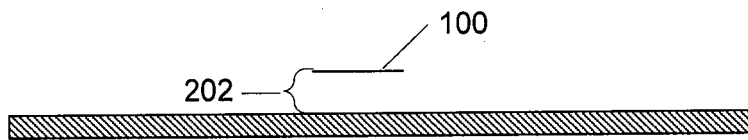

FIG. 2

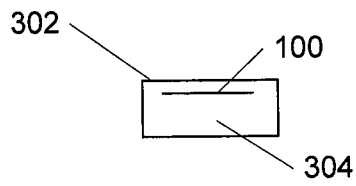

FIG. 3

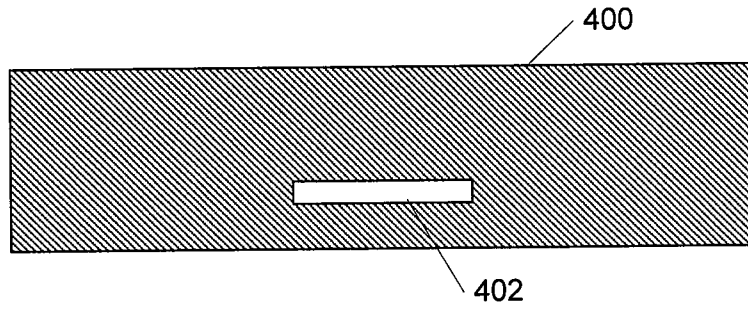

FIG. 4A

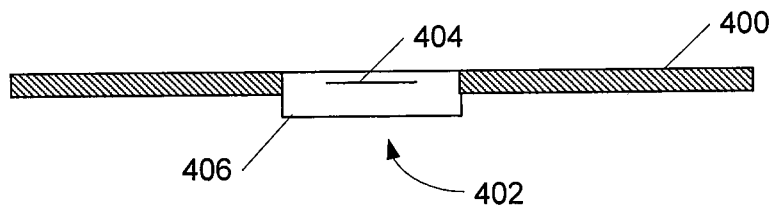

FIG. 4B

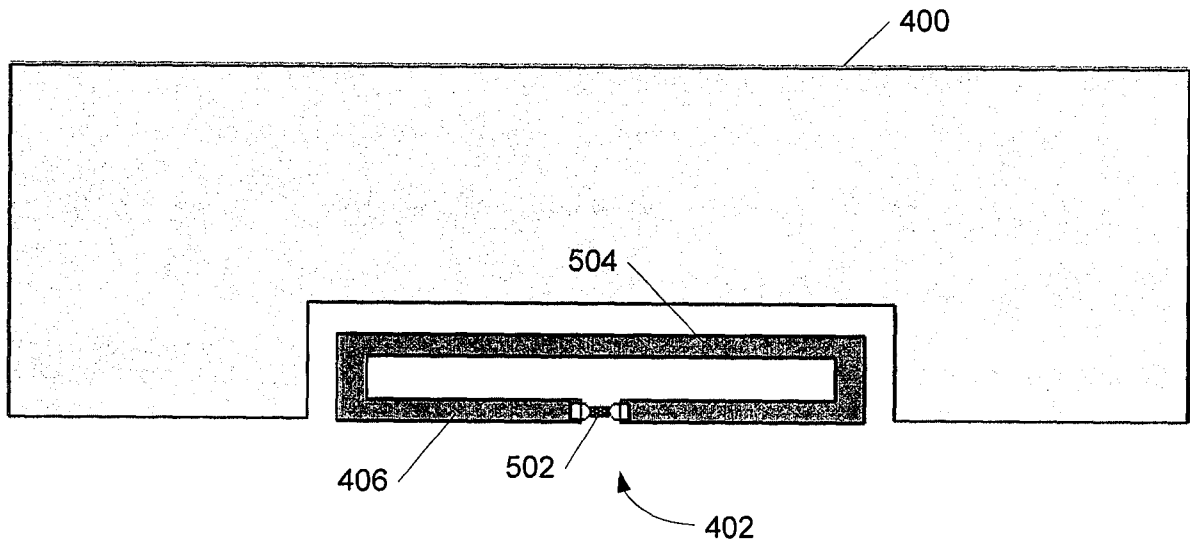

FIG. 5A

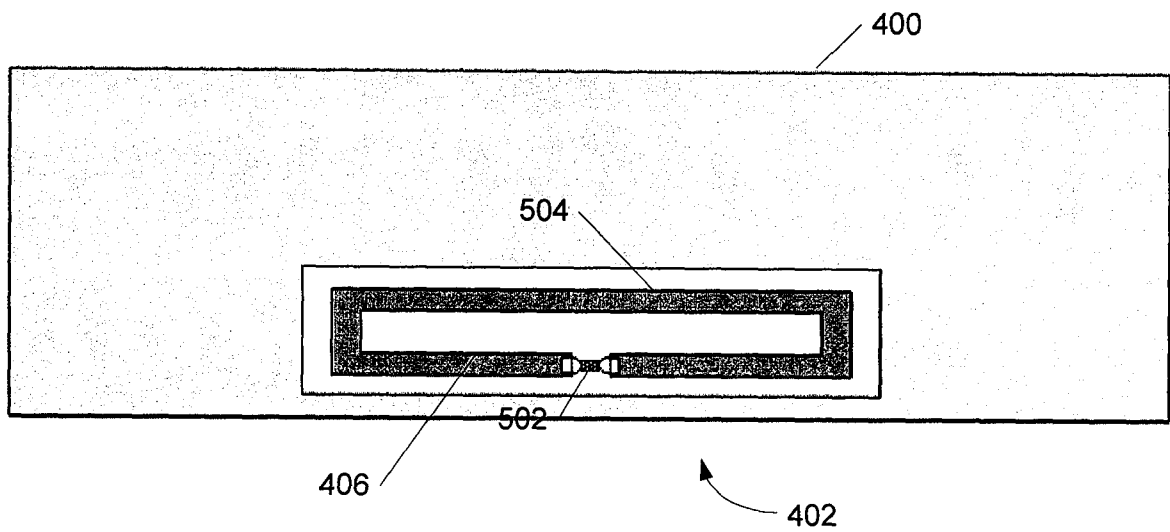
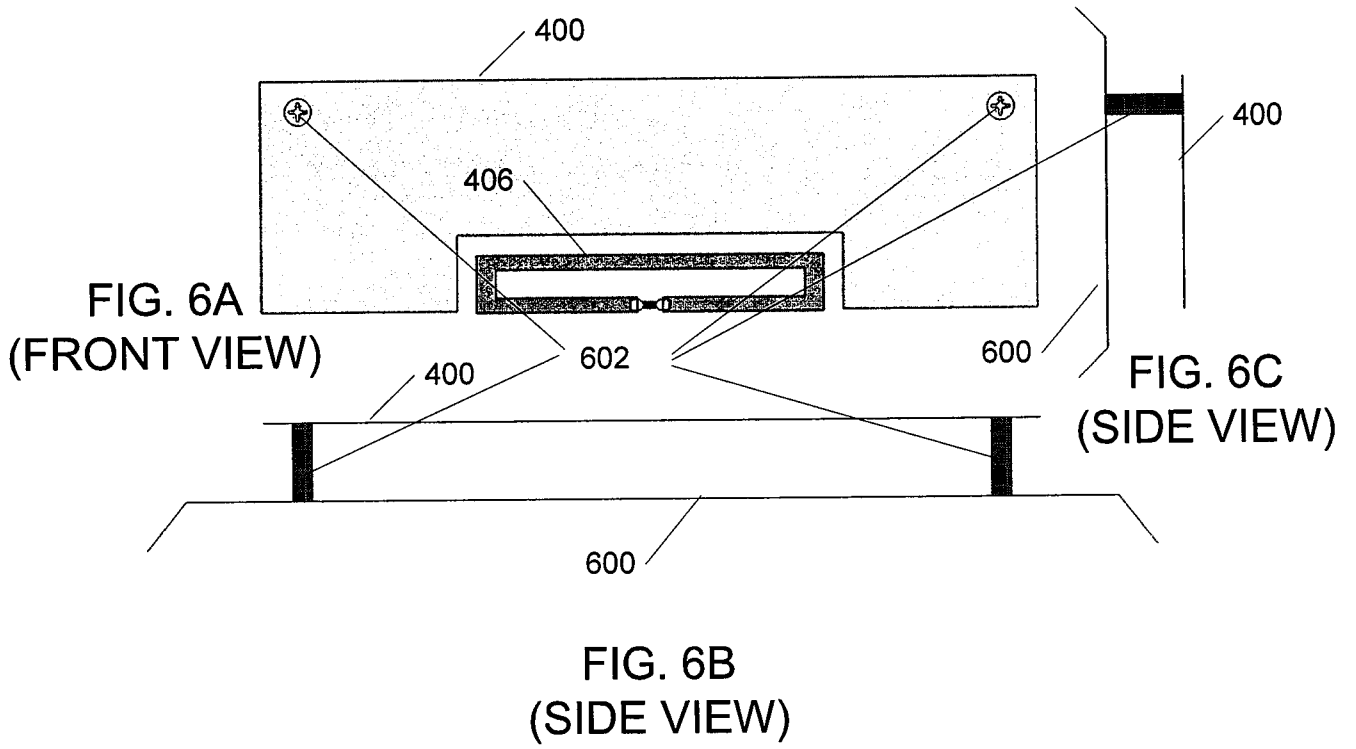

FIG. 5B



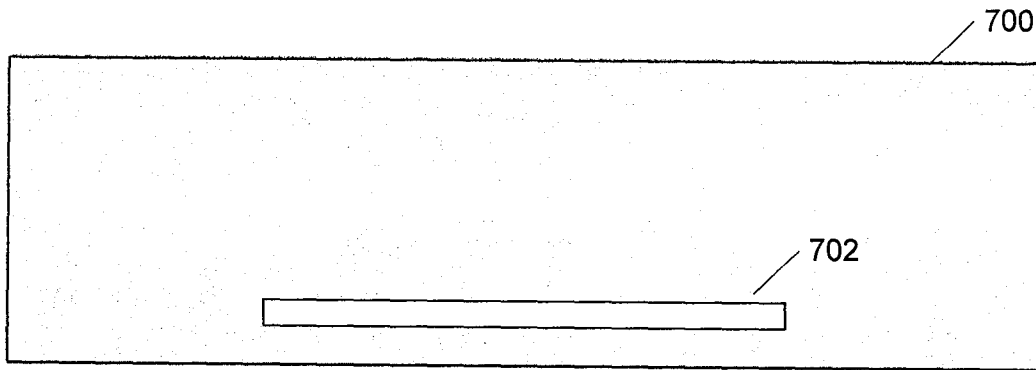

FIG. 7A

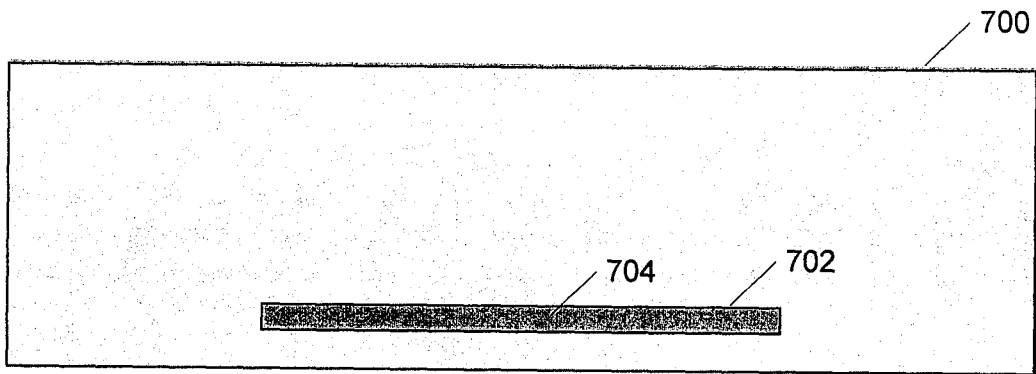

FIG. 7B

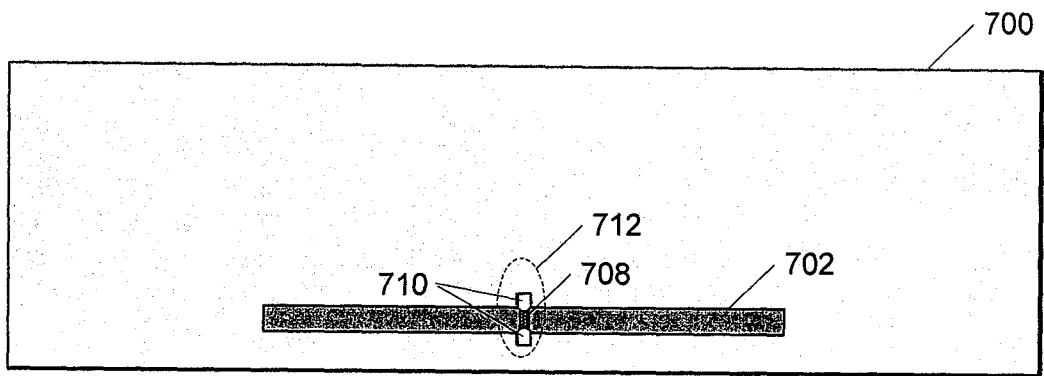

FIG. 7C

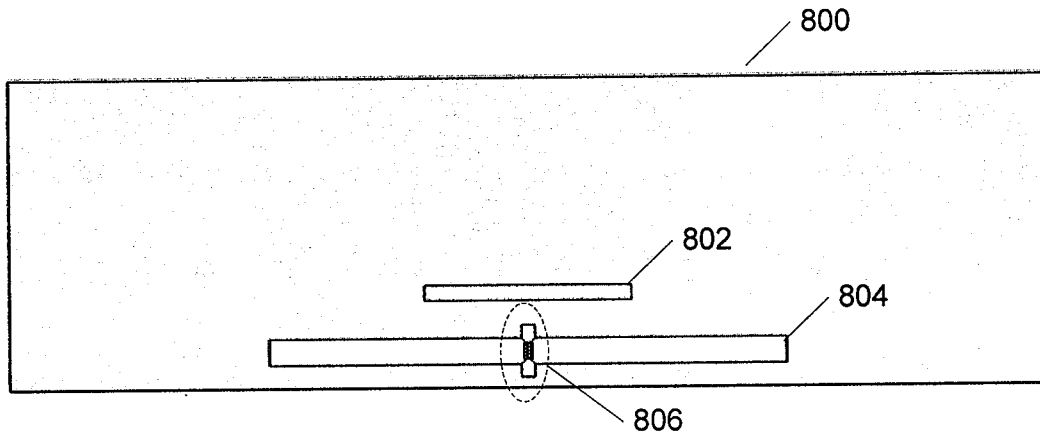

FIG. 8

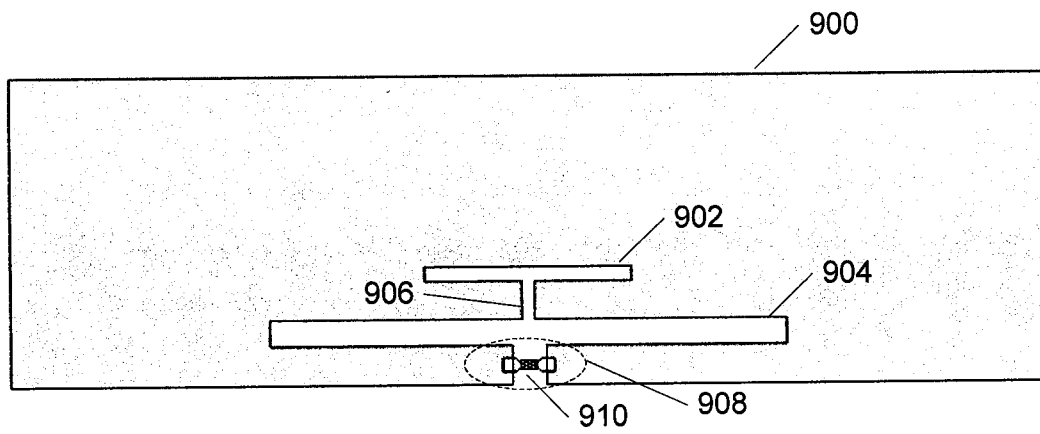
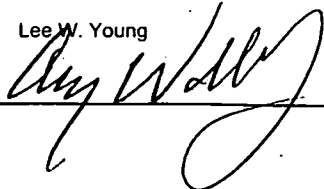

FIG. 9

INTERNATIONAL SEARCH REPORT

International application No.

PCT/US 07/88227

A. CLASSIFICATION OF SUBJECT MATTER IPC(8) - G08B 13/14 (2008.01) USPC - 340/572.7 According to International Patent Classification (IPC) or to both national classification and IPC													
B. FIELDS SEARCHED Minimum documentation searched (classification system followed by classification symbols) USPC: 340/572.7 Documentation searched other than minimum documentation to the extent that such documents are included in the fields searched US: 340/572.7, 572.8 (keyword limited - see terms below) Electronic data base consulted during the international search (name of data base and, where practicable, search terms used) PubWEST(PGPB, USPT, USOC, EPAB, JPAB); GOOGLE Search Terms: RFID, loop, coupling, inductive coupling, capacitive coupling, license-plate, licenseplate, license plate, chip, IC, antenna, toll, dielectric, reflective, spacer, housing, enclosure, retro-reflective, retroreflective, ground													
C. DOCUMENTS CONSIDERED TO BE RELEVANT													
<table border="1"> <thead> <tr> <th>Category*</th> <th>Citation of document, with indication, where appropriate, of the relevant passages</th> <th>Relevant to claim No.</th> </tr> </thead> <tbody> <tr> <td>X --- Y</td> <td>US 2006/0261950 A1 (Arneson et al.) 23 November 2006 (23.11.2006), entire document, especially; abstract, para. [0012], [0021], [0042], [0045], [0059], [0108], [0105], [0115], [0180]</td> <td>13-21, 24 ----- 1-12, 22, 23, 25-44</td> </tr> <tr> <td>Y</td> <td>US 2004/0095241 A1 (Maloney) 20 May 2004 (20.05.2004), entire document, especially; abstract</td> <td>1-12, 22, 23, 25-34</td> </tr> <tr> <td>Y</td> <td>US 2003/0067389 A1 (Look) 10 April 2003 (10.04.2003), entire document, especially; abstract, para. [0015], Claim 6</td> <td>10, 11, 22, 23, 25-44</td> </tr> </tbody> </table>	Category*	Citation of document, with indication, where appropriate, of the relevant passages	Relevant to claim No.	X --- Y	US 2006/0261950 A1 (Arneson et al.) 23 November 2006 (23.11.2006), entire document, especially; abstract, para. [0012], [0021], [0042], [0045], [0059], [0108], [0105], [0115], [0180]	13-21, 24 ----- 1-12, 22, 23, 25-44	Y	US 2004/0095241 A1 (Maloney) 20 May 2004 (20.05.2004), entire document, especially; abstract	1-12, 22, 23, 25-34	Y	US 2003/0067389 A1 (Look) 10 April 2003 (10.04.2003), entire document, especially; abstract, para. [0015], Claim 6	10, 11, 22, 23, 25-44	
Category*	Citation of document, with indication, where appropriate, of the relevant passages	Relevant to claim No.											
X --- Y	US 2006/0261950 A1 (Arneson et al.) 23 November 2006 (23.11.2006), entire document, especially; abstract, para. [0012], [0021], [0042], [0045], [0059], [0108], [0105], [0115], [0180]	13-21, 24 ----- 1-12, 22, 23, 25-44											
Y	US 2004/0095241 A1 (Maloney) 20 May 2004 (20.05.2004), entire document, especially; abstract	1-12, 22, 23, 25-34											
Y	US 2003/0067389 A1 (Look) 10 April 2003 (10.04.2003), entire document, especially; abstract, para. [0015], Claim 6	10, 11, 22, 23, 25-44											
<input type="checkbox"/> Further documents are listed in the continuation of Box C. <input type="checkbox"/>													
<table border="0"> <tr> <td>* Special categories of cited documents:</td> <td>"T" later document published after the international filing date or priority date and not in conflict with the application but cited to understand the principle or theory underlying the invention</td> </tr> <tr> <td>"A" document defining the general state of the art which is not considered to be of particular relevance</td> <td>"X" document of particular relevance; the claimed invention cannot be considered novel or cannot be considered to involve an inventive step when the document is taken alone</td> </tr> <tr> <td>"E" earlier application or patent but published on or after the international filing date</td> <td>"Y" document of particular relevance; the claimed invention cannot be considered to involve an inventive step when the document is combined with one or more other such documents, such combination being obvious to a person skilled in the art</td> </tr> <tr> <td>"L" document which may throw doubts on priority claim(s) or which is cited to establish the publication date of another citation or other special reason (as specified)</td> <td>"&" document member of the same patent family</td> </tr> <tr> <td>"O" document referring to an oral disclosure, use, exhibition or other means</td> <td></td> </tr> <tr> <td>"P" document published prior to the international filing date but later than the priority date claimed</td> <td></td> </tr> </table>		* Special categories of cited documents:	"T" later document published after the international filing date or priority date and not in conflict with the application but cited to understand the principle or theory underlying the invention	"A" document defining the general state of the art which is not considered to be of particular relevance	"X" document of particular relevance; the claimed invention cannot be considered novel or cannot be considered to involve an inventive step when the document is taken alone	"E" earlier application or patent but published on or after the international filing date	"Y" document of particular relevance; the claimed invention cannot be considered to involve an inventive step when the document is combined with one or more other such documents, such combination being obvious to a person skilled in the art	"L" document which may throw doubts on priority claim(s) or which is cited to establish the publication date of another citation or other special reason (as specified)	"&" document member of the same patent family	"O" document referring to an oral disclosure, use, exhibition or other means		"P" document published prior to the international filing date but later than the priority date claimed	
* Special categories of cited documents:	"T" later document published after the international filing date or priority date and not in conflict with the application but cited to understand the principle or theory underlying the invention												
"A" document defining the general state of the art which is not considered to be of particular relevance	"X" document of particular relevance; the claimed invention cannot be considered novel or cannot be considered to involve an inventive step when the document is taken alone												
"E" earlier application or patent but published on or after the international filing date	"Y" document of particular relevance; the claimed invention cannot be considered to involve an inventive step when the document is combined with one or more other such documents, such combination being obvious to a person skilled in the art												
"L" document which may throw doubts on priority claim(s) or which is cited to establish the publication date of another citation or other special reason (as specified)	"&" document member of the same patent family												
"O" document referring to an oral disclosure, use, exhibition or other means													
"P" document published prior to the international filing date but later than the priority date claimed													
Date of the actual completion of the international search 28 March 2008 (28.03.2008)	Date of mailing of the international search report 01 MAY 2008												
Name and mailing address of the ISA/US Mail Stop PCT, Attn: ISA/US, Commissioner for Patents P.O. Box 1450, Alexandria, Virginia 22313-1450 Facsimile No. 571-273-3201	Authorized officer: Lee W. Young  PCT Helpdesk: 571-272-4300 PCT OSP: 571-272-7774												