

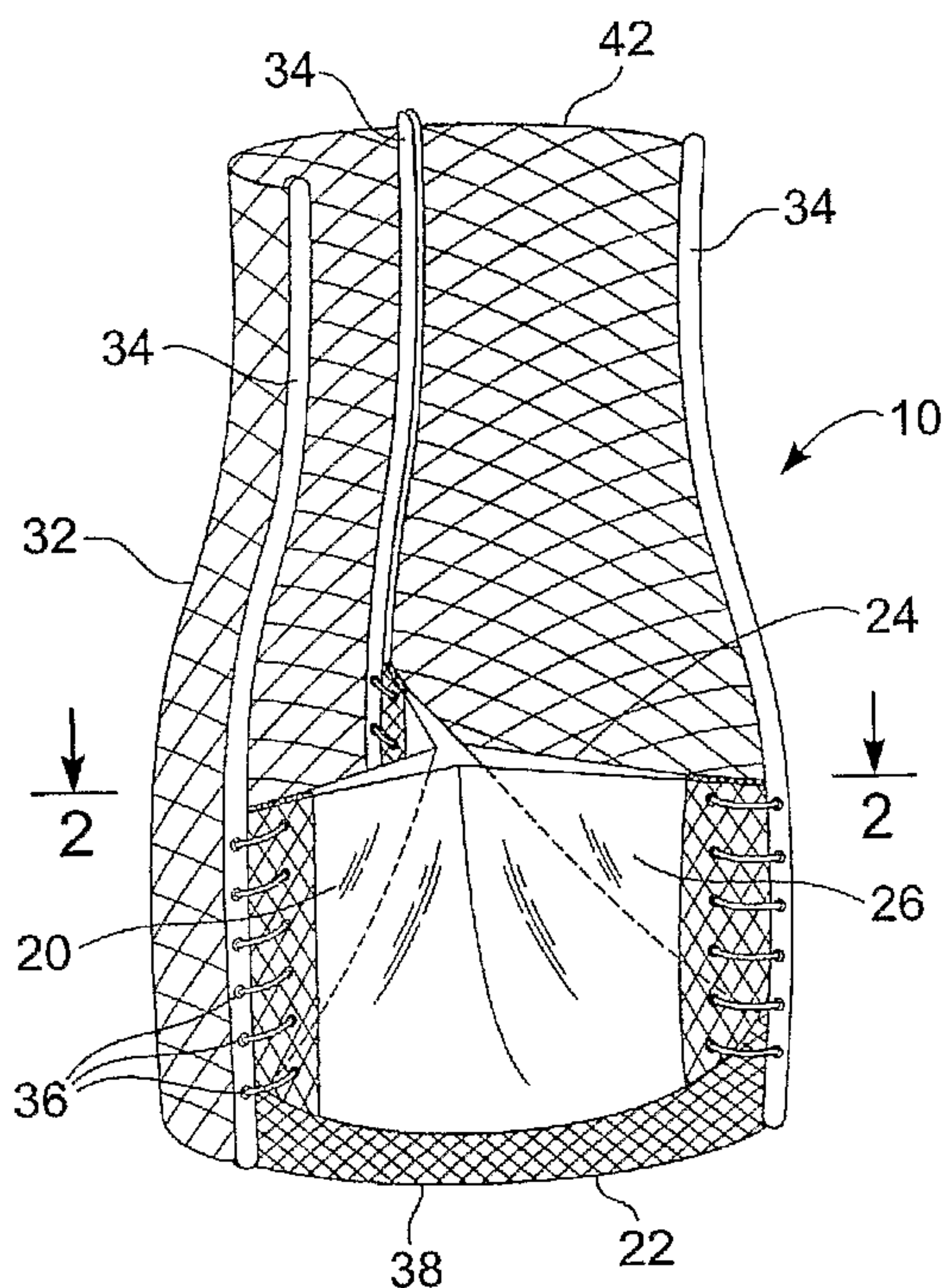

(86) Date de dépôt PCT/PCT Filing Date: 2004/10/01  
 (87) Date publication PCT/PCT Publication Date: 2005/04/21  
 (85) Entrée phase nationale/National Entry: 2006/03/31  
 (86) N° demande PCT/PCT Application No.: US 2004/032388  
 (87) N° publication PCT/PCT Publication No.: 2005/034812  
 (30) Priorité/Priority: 2003/10/02 (US10/677,947)

(51) Cl.Int./Int.Cl. *A61F 2/24* (2006.01)  
 (71) Demandeur/Applicant:  
EDWARDS LIFESCIENCES CORPORATION, US  
 (72) Inventeur/Inventor:  
ROWE, STANTON, US  
 (74) Agent: STIKEMAN ELLIOTT LLP

(54) Titre : VALVE PROTHETIQUE IMPLANTABLE A ECOULEMENT NON LAMINAIRE  
 (54) Title: IMPLANTABLE PROSTHETIC VALVE WITH NON-LAMINAR FLOW



(57) **Abrégé/Abstract:**

A valve prosthesis device is disclosed suitable for implantation in body ducts. The device comprises a support stent, comprised of a deployable construction adapted to be initially crimped in a narrow configuration suitable for catheterization through the body duct to a target location and adapted to be deployed by exerting substantially radial forces from within by means of a deployment device to a deployed state in the target location, and a valve assembly comprising a flexible conduit having an inlet end and an outlet, made of pliant material attached to the support beams providing collapsible slack portions of the conduit at the outlet. The support stent is provided with a plurality of longitudinally rigid support beams of fixed length. When flow is allowed to pass through the valve prosthesis device from the inlet to the outlet, the valve assembly is kept in an open position, whereas a reverse flow is prevented as the collapsible slack portions of the valve assembly collapse inwardly providing blockage to the reverse flow. The device is configured so that retrograde flow will be altered from laminar flow and directed towards the leaflets to effect closing.

(12) INTERNATIONAL APPLICATION PUBLISHED UNDER THE PATENT COOPERATION TREATY (PCT)

(19) World Intellectual Property  
Organization  
International Bureau



(43) International Publication Date  
21 April 2005 (21.04.2005)

PCT

(10) International Publication Number  
**WO 2005/034812 A1**

- (51) International Patent Classification<sup>7</sup>: **A61F 2/24** (74) Agents: **CONDINO, Debra, D.** et al.; Edwards Lifesciences LLC, One Edwards Way, Irvine, CA 92614 (US).
- (21) International Application Number: PCT/US2004/032388 (81) Designated States (unless otherwise indicated, for every kind of national protection available): AE, AG, AL, AM, AT, AU, AZ, BA, BB, BG, BR, BW, BY, BZ, CA, CH, CN, CO, CR, CU, CZ, DE, DK, DM, DZ, EC, EE, EG, ES, FI, GB, GD, GE, GH, GM, HR, HU, ID, IL, IN, IS, JP, KE, KG, KP, KR, KZ, LC, LK, LR, LS, LT, LU, LV, MA, MD, MG, MK, MN, MW, MX, MZ, NA, NI, NO, NZ, OM, PG, PH, PL, PT, RO, RU, SC, SD, SE, SG, SK, SL, SY, TJ, TM, TN, TR, TT, TZ, UA, UG, US, UZ, VC, VN, YU, ZA, ZM, ZW.
- (22) International Filing Date: 1 October 2004 (01.10.2004)
- (25) Filing Language: English
- (26) Publication Language: English
- (30) Priority Data:  
10/677,947 2 October 2003 (02.10.2003) US
- (71) Applicant (for all designated States except US): **EDWARDS LIFESCIENCES CORPORATION** [US/US]; One Edwards Way, Irvine, CA 92614 (US).
- (71) Applicant and  
(72) Inventor: **ROWE, Stanton** [US/US]; 117 Old Course Drive, Newport Beach, CA 92660 (US).
- (84) Designated States (unless otherwise indicated, for every kind of regional protection available): ARIPO (BW, GH, GM, KE, LS, MW, MZ, NA, SD, SL, SZ, TZ, UG, ZM, ZW), Eurasian (AM, AZ, BY, KG, KZ, MD, RU, TJ, TM), European (AT, BE, BG, CH, CY, CZ, DE, DK, EE, ES, FI, FR, GB, GR, HU, IE, IT, LU, MC, NL, PL, PT, RO, SE, SI,

[Continued on next page]

(54) Title: IMPLANTABLE PROSTHETIC VALVE WITH NON-LAMINAR FLOW

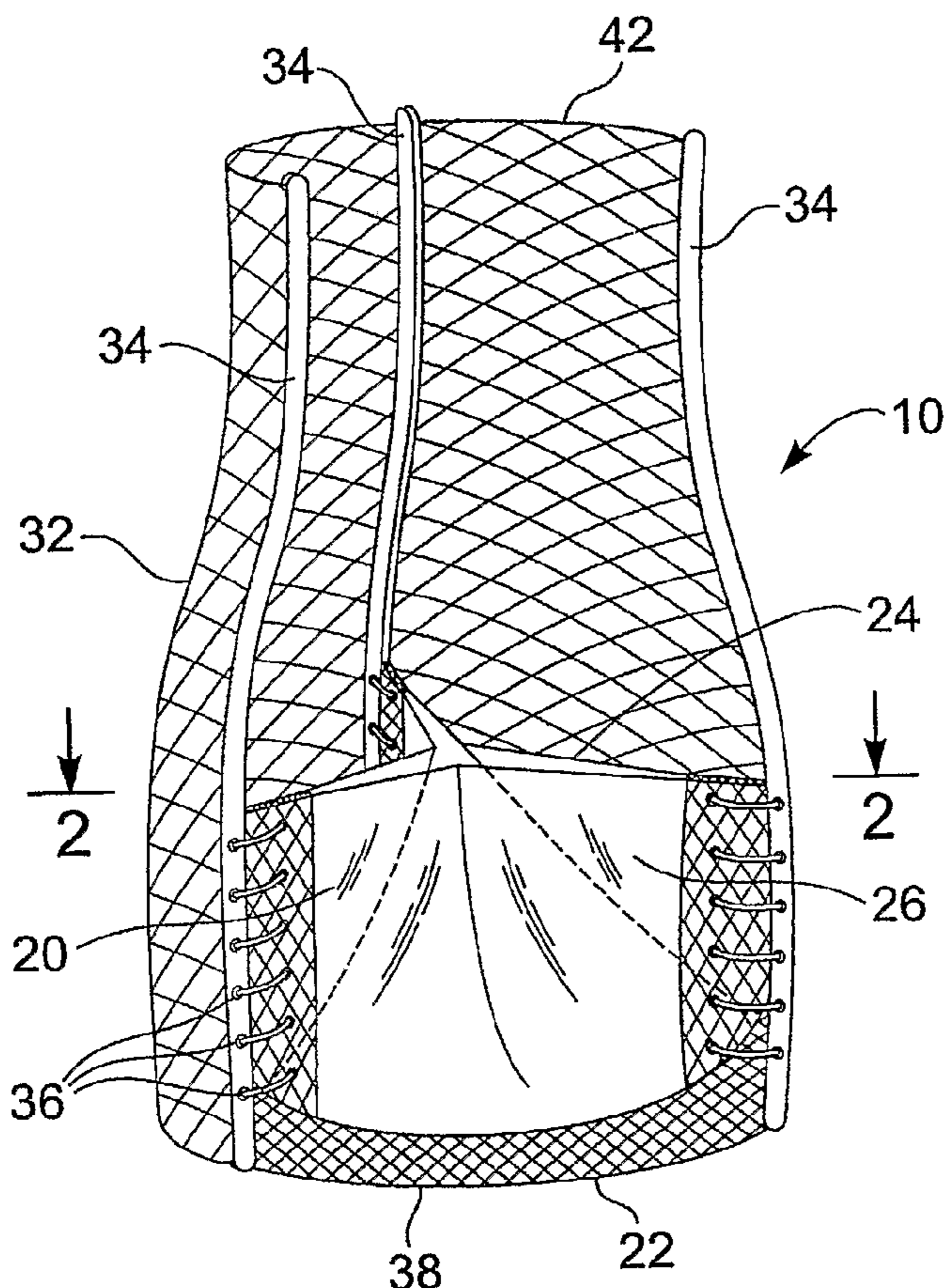

(57) Abstract: A valve prosthesis device is disclosed suitable for implantation in body ducts. The device comprises a support stent, comprised of a deployable construction adapted to be initially crimped in a narrow configuration suitable for catheterization through the body duct to a target location and adapted to be deployed by exerting substantially radial forces from within by means of a deployment device to a deployed state in the target location, and a valve assembly comprising a flexible conduit having an inlet end and an outlet, made of pliant material attached to the support beams providing collapsible slack portions of the conduit at the outlet. The support stent is provided with a plurality of longitudinally rigid support beams of fixed length. When flow is allowed to pass through the valve prosthesis device from the inlet to the outlet, the valve assembly is kept in an open position, whereas a reverse flow is prevented as the collapsible slack portions of the valve assembly collapse inwardly providing blockage to the reverse flow. The device is configured so that retrograde flow will be altered from laminar flow and directed towards the leaflets to effect closing.

WO 2005/034812 A1

**WO 2005/034812 A1**



SK, TR), OAPI (BF, BJ, CF, CG, CI, CM, GA, GN, GQ,  
GW, ML, MR, NE, SN, TD, TG).

*For two-letter codes and other abbreviations, refer to the "Guidance Notes on Codes and Abbreviations" appearing at the beginning of each regular issue of the PCT Gazette.*

**Published:**

— *with international search report*

## IMPLANTABLE PROSTHETIC VALVE WITH NON-LAMINAR FLOW

### FIELD OF THE INVENTION

**[0001]** The present invention relates to implantable prosthetic  
5 valves. More particularly, the invention relates to a valve prosthesis for  
cardiac implantation or for implantation in other body ducts where the  
prosthesis has improved flow characteristics.

### BACKGROUND OF THE INVENTION

**[0002]** Several prosthetic valves are known. See, for example,  
10 U.S. Patent No. 5,411,552 (Andersen et al.), entitled VALVE  
PROSTHESIS FOR IMPLANTATION IN THE BODY AND  
CATHETER FOR IMPLANTING SUCH VALVE PROSTHESIS, which  
discloses a valve prosthesis comprising a stent made from an expandable  
cylinder-shaped thread structure comprising several spaced apices. See,  
15 also, U.S. Patent No. 6,168,614 (Andersen et al.), entitled VALVE  
PROSTHESIS FOR IMPLANTATION IN THE BODY, U.S. Patent No.  
5,840,081 (Andersen et al.), entitled SYSTEM AND METHOD FOR  
IMPLANTING CARDIAC VALVES, and PCT Application No.  
PCT/EP97/07337 (Letac, Cribier et al.), published as WO 98/29057,  
20 entitled VALVE PROSTHESIS FOR IMPLANTATION IN BODY  
CHANNELS, all of which are incorporated herein by reference.

**[0003]** In the development of stented valves, a highly desirable,  
and often preferred design utilizes a cylindrical stent platform of either  
balloon expandable or self-expanding metal designs. Usually these stents  
25 follow the cellular designs which tend to have higher radial strength and  
less foreshortening than wire-wound platforms.

[0004] Such cylindrical stents offer a stable and reproducible expansion platform for attaching valves and may be manufactured from a variety of biocompatible metals including stainless steels, titanium alloys, platinum-iridium, nickel-titanium alloys, chromium alloys, or tantalum.

5 [0005] Polymeric, bovine venous, pericardial, and porcine valve constructs have lead the early development efforts of stent-valve designs. All of the early designs have utilized either bicuspid or tricuspid valve designs.

[0006] One of the key factors that determines the long term  
10 functionality of stented valves is the retrograde flow characteristics. The retrograde flow characteristics, along with the stiffness characteristics of the valve material, will determine leakage and closing pressure requirements. The retrograde flow characteristics are most important in  
low flow/low pressure systems where the valve leaflets may thrombose in  
15 the presence of poor retrograde laminar flow.

[0007] Stented valves are passive devices. The valves function as a result of changes in pressure and flow. An aortic stented valve opens passively when the pressure in the left ventricle exceeds the pressure in the aorta (plus any resistance required to open the valve). The valve  
20 closes when the pressure in the left ventricle is less than the pressure in the aorta. However, the flow characteristics are critical to effect the closing of the aortic valve, otherwise regurgitation will ensue.

[0008] Laminar flow is the normal condition found in most of the circulatory system. It is characterized by concentric layers of blood  
25 moving in parallel down the length of the blood vessel. The highest velocity is found in the middle of the blood vessel while the lowest is

found along the wall. The flow is parabolic in a long straight vessel under steady flow conditions.

**[0009]** Non-laminar, or turbulent, flow is useful to the circulatory system. For example, the aortic valve opens into the sinus of Valsalva at the inferior aspect of the ascending aorta. This sinus has two key functions: First, it maximizes the flow characteristics so that the aortic valve closes during diastole. And second, it optimizes coronary sinus flow and perfusion.

**[0010]** Laminar flow makes the retrograde flow characteristics of valves mounted in cylindrical stents problematic as the flow along the wall is least, which is central to the closing of a valve. Such laminar flow with its attendant drawbacks is a characteristic of known stented valves. There is a need to have stented valves where the retrograde flow characteristics will be non-laminar, which will be advantageous with regard to valve closing.

#### SUMMARY OF THE INVENTION

**[0011]** According to the invention, a valve prosthesis device suitable for implantation in body ducts comprises:

**[0012]** a support stent having support beams; and

**[0013]** a valve assembly comprising a flexible conduit having an inlet end and an outlet end, made of pliant material attached to the support beams,

**[0014]** wherein when flow is allowed to pass through the valve prosthesis device from the inlet end to the outlet end, the valve assembly

is kept in an open position; wherein a reverse flow is prevented as portions of the valve assembly collapse inwardly providing blockage to the reverse flow; and wherein the device is configured so that retrograde flow will be altered from laminar flow and directed towards the leaflets to effect closing.

**[0015]** In accordance with a preferred embodiment of the present invention, a valve prosthesis device suitable for implantation in body ducts comprises:

**[0016]** a support stent, comprised of a deployable construction adapted to be initially crimped in a narrow configuration suitable for catheterization through the body duct to a target location and adapted to be deployed by exerting substantially radial forces from within by means of a deployment device to a deployed state in the target location, the support stent provided with a plurality of longitudinally generally rigid support beams of fixed length; and

**[0017]** a valve assembly comprising a flexible conduit having an inlet and an outlet, made of pliant material attached to the support beams providing collapsible slack portions of the conduit at the outlet,

**[0018]** wherein when flow is allowed to pass through the valve prosthesis device from the inlet to the outlet, the valve assembly is kept in an open position; wherein a reverse flow is prevented as the collapsible slack portions of the valve assembly collapse inwardly providing blockage to the reverse flow; and wherein the device is configured so that retrograde flow will be altered from laminar flow and directed towards the leaflets to effect closing.

[0019] Furthermore, in accordance with another preferred embodiment of the present invention, the support stent comprises an annular frame.

[0020] Furthermore, in accordance with another preferred embodiment of the present invention, the expanded prosthesis comprises a sinus area adjacent the valve assembly.

[0021] Furthermore, in accordance with another preferred embodiment of the invention, the support stent comprises an annular frame wherein the middle portion of the expanded annular frame extends radially to create a sinus adjacent the valve assembly.

[0022] Furthermore, in accordance with another preferred embodiment of the present invention, the support stent comprises an annular frame with a valve assembly arranged therein to redirect flow towards the valve assembly.

[0023] Furthermore, in accordance with another preferred embodiment of the present invention, said valve assembly has a tricuspid configuration.

[0024] Furthermore, in accordance with another preferred embodiment of the present invention, the valve assembly is made from biocompatible material.

[0025] Furthermore, in accordance with another preferred embodiment of the present invention, the valve assembly is made from pericardial tissue, or other biological tissue.



[0026] Furthermore, in accordance with another preferred embodiment of the present invention, the valve assembly is made from biocompatible polymers.

[0027] Furthermore, in accordance with another preferred  
5 embodiment of the present invention, the valve assembly is made from materials selected from the group consisting of polyurethane and polyethylene terephthalate (PET).

[0028] Furthermore, in accordance with another preferred  
10 embodiment of the present invention, the valve assembly comprises a main body made from PET (polyethylene terephthalate) and leaflets made from polyurethane.

[0029] Furthermore, in accordance with another preferred embodiment of the present invention, the support stent is made from nickel titanium.

15 [0030] Furthermore, in accordance with another preferred embodiment of the present invention, the support beams are substantially equidistant and substantially parallel so as to provide anchorage for the valve assembly.

[0031] Furthermore, in accordance with another preferred  
20 embodiment of the present invention, the support beams are provided with bores so as to allow stitching or tying of the valve assembly to the beams.

[0032] Furthermore, in accordance with another preferred  
25 embodiment of the present invention, the support beams are chemically adhered to the support stent.

[0033] Furthermore, in accordance with another preferred embodiment of the present invention, the valve assembly is riveted to the support beams.

[0034] Furthermore, in accordance with another preferred  
5 embodiment of the present invention, said valve assembly is sutured to the support beams.

[0035] Furthermore, in accordance with another preferred embodiment of the present invention, the beams are manufactured by injection using a mold, or by machining.

10 [0036] Furthermore, in accordance with another preferred embodiment of the present invention, the valve assembly is rolled over the support stent at the inlet.

[0037] Furthermore, in accordance with another preferred  
15 embodiment of the present invention, the valve device is manufactured using forging or dipping techniques.

[0038] Furthermore, in accordance with another preferred embodiment of the present invention, the valve assembly leaflets are longer than needed to exactly close the outlet, thus when they are in the collapsed state substantial portions of the leaflets fall on each other  
20 creating better sealing.

[0039] Furthermore, in accordance with another preferred embodiment of the present invention, the valve assembly is made from coils of a polymer, coated by a coating layer of same polymer.

[0040] Furthermore, in accordance with another preferred embodiment of the present invention, the polymer is polyurethane.

[0041] Furthermore, in accordance with another preferred embodiment of the present invention, the support stent is provided with  
5 heavy metal markers to enable tracking and determining the valve device position and orientation.

[0042] Furthermore, in accordance with another preferred embodiment of the present invention, the heavy metal markers are selected from the group consisting of gold, platinum-iridium, and  
10 tantalum.

[0043] Furthermore, in accordance with another preferred embodiment of the present invention, the valve assembly leaflets are provided with radio-opaque material at the outlet, to help tracking the valve device operation in vivo.

15 [0044] Furthermore, in accordance with another preferred embodiment of the present invention, the radio-opaque material comprises gold thread.

[0045] Furthermore, in accordance with another preferred embodiment of the present invention, the diameter of the support stent,  
20 when fully deployed, is in the range of from about 19 to about 26 mm.

[0046] Furthermore, in accordance with another preferred embodiment of the present invention, the diameter of the support stent may be expanded from about 4 to about 25 mm.

[0047] Furthermore, in accordance with another preferred embodiment of the present invention, the support beams are provided with bores and wherein the valve assembly is attached to the support beams by means of U-shaped rigid members that are fastened to the valve assembly and that are provided with extruding portions that fit into matching bores on the support beams.

[0048] Furthermore, in accordance with another preferred embodiment of the present invention, the support beams comprise rigid support beams in the form of frame construction, and the valve assembly pliant material is inserted through a gap in the frame and a fastening rod is inserted through a pocket formed between the pliant material and the frame and holds the valve in position.

[0049] Furthermore, in accordance with another preferred embodiment of the present invention, the main body of the valve assembly is made from coiled wire coated with coating material.

[0050] Furthermore, in accordance with another preferred embodiment of the present invention, the coiled wire and the coating material is made from polyurethane.

[0051] Furthermore, in accordance with another preferred embodiment of the present invention, a strengthening wire is interlaced in the valve assembly at the outlet of the conduit so as to define a fault line about which the collapsible slack portion of the valve assembly may flap.

[0052] Furthermore, in accordance with another preferred embodiment of the present invention, the strengthening wire is made from nickel titanium alloy.

[0053] Furthermore, in accordance with another preferred embodiment of the present invention, there is provided a valve prosthesis device suitable for implantation in body ducts, the device comprising a main conduit body having an inlet and an outlet and pliant leaflets  
5 attached at the outlet so that when a flow passes through the conduit from the inlet to the outlet the leaflets are in an open position allowing the flow to exit the outlet, and when the flow is reversed the leaflets collapse so as to block the outlet, wherein the main body is made from PET and collapsible leaflets are made from polyurethane.

10 [0054] Furthermore, in accordance with another preferred embodiment of the present invention, support beams made from polyurethane are provided on the main body and wherein the leaflets are attached to the main body at the support beams.

[0055] Furthermore, in accordance with another preferred  
15 embodiment of the present invention, said support beams are chemically adhered to the main body.

[0056] Furthermore, in accordance with another preferred embodiment of the present invention, there is provided a valve prosthesis device suitable for implantation in body ducts, the device comprising:

20 [0057] a support stent, comprised of a deployable construction adapted to be initially crimped in a narrow configuration suitable for catheterization through the body duct to a target location and adapted to be deployed by exerting substantially radial forces from within by means of a deployment device to a deployed state in the target location, the  
25 support stent provided with a plurality of longitudinally rigid support beams of fixed length;

[0058] a valve assembly comprising a flexible conduit having an inlet end and an outlet, made of pliant material attached to the support beams providing collapsible slack portions of the conduit at the outlet; and

5 [0059] substantially equidistant rigid support beams interlaced or attached to the slack portion of the valve assembly material, arranged longitudinally,

[0060] wherein the device is configured so that retrograde flow will be altered from laminar flow and directed towards the leaflets to effect  
10 closing.

[0061] Furthermore, in accordance with another preferred embodiment of the present invention, there is provided a crimping device for crimping the valve device described above or in the claims below, the crimping device comprising a plurality of adjustable plates that resemble  
15 a typical SLR (Single Lens Reflex) camera variable restrictor, each provided with a blade, that are equally dispersed in a radial symmetry but each plate moves along a line passing off an opening in the center, all plates equidistant from that center opening.

[0062] Furthermore, in accordance with another preferred  
20 embodiment of the present invention, the multiple plates are adapted to move simultaneously by means of a lever and transmission.

[0063] Furthermore, in accordance with another preferred embodiment of the present invention, there is provided a method for deploying an implantable prosthetic valve device from the retrograde  
25 approach (approaching the aortic valve from the descending aorta) or

from the antegrade approach (approaching the aortic valve from the left ventricle after performing a trans-septal puncture) at the natural aortic valve position at the entrance to the left ventricle of a myocardium of a patient. This method is described in co-pending, commonly assigned  
5 U.S. patent applications Serial Nos. 09/975,750, filed October 11, 2001, and 10,139,741, filed May 2, 2002, each of which is incorporated herein by reference in its entirety.

**[0064]** Furthermore, in accordance with another preferred embodiment of the present invention, a valve prosthesis device suitable  
10 for implantation in body ducts comprises:

**[0065]** an expandable support frame, the support frame provided with a plurality of longitudinally rigid support beams of fixed length; and

**[0066]** a valve assembly comprising a flexible conduit having an inlet end and an outlet, made of pliant material attached to the support  
15 beams providing collapsible slack portions of the conduit at the outlet,

**[0067]** wherein when flow is allowed to pass through the valve prosthesis device from the inlet to the outlet, the valve assembly is kept in an open position; wherein a reverse flow is prevented as the collapsible slack portions of the valve assembly collapse inwardly providing  
20 blockage to the reverse flow; and wherein the device is configured so that retrograde flow will be altered from laminar flow and directed towards the leaflets to effect closing .

**[0068]** Furthermore, in accordance with another preferred embodiment of the present invention, the support frame comprises a  
25 deployable construction adapted to be initially crimped in a narrow

configuration suitable for catheterization through the body duct to a target location and adapted to be deployed by exerting substantially radial forces from within by means of a deployment device to a deployed state in the target location.

5 [0069] Furthermore, in accordance with another preferred embodiment of the present invention, the support beams have a U-shaped cross section.

[0070] Furthermore, in accordance with another preferred embodiment of the present invention, a holder is used to secure the plaint  
10 material to the support beams.

[0071] Furthermore, in accordance with another preferred embodiment of the present invention, the support frame comprises three segments that form a circular assembly when assembled.

[0072] Furthermore, in accordance with another preferred  
15 embodiment of the present invention, the support beams point inwardly with respect to a central longitudinal axis of the device.

[0073] Furthermore, in accordance with another preferred embodiment of the present invention, the device is further provided with a restricting tapered housing, for housing it in a crimped state.

20 [0074] Furthermore, in accordance with another preferred embodiment of the present invention, hooks are provided to secure the device in position after it is deployed.

[0075] Furthermore, in accordance with another preferred embodiment of the present invention, the support beams comprise



longitudinal bars having a narrow slit used as the commissural attachment so that extensions the pliant material are tightly inserted through it.

[0076] Furthermore, in accordance with another preferred embodiment of the present invention, the extensions of the pliant material  
5 are wrapped about rigid bars serving as anchorage means.

[0077] Furthermore, in accordance with another preferred embodiment of the present invention, extensions of the pliant material are sutured to each other at the rigid bars.

[0078] Furthermore, in accordance with another preferred  
10 embodiment of the present invention, a bottom portion of the pliant material is attached to the inlet.

[0079] Furthermore, in accordance with another preferred embodiment of the present invention, the support beams are each provided with a rounded pole, forming a loop through which the pliant  
15 material is inserted.

[0080] Furthermore, in accordance with another preferred embodiment of the present invention, the pliant material is provided with longitudinal bars attached to the pliant material at positions assigned for attachment to the support frame, in order to prevent localized stress from  
20 forming.

[0081] Furthermore, in accordance with another preferred embodiment of the present invention, the device is further provided with longitudinal bars having protrusions that are inserted in bores in the pliant material, a sheet of PET and through bores provided on the support  
25 beams.

[0082] Furthermore, in accordance with another preferred embodiment of the present invention, pliant material is sutured leaving the slack portions free of sutures.

[0083] Furthermore, in accordance with another preferred  
5 embodiment of the present invention, a connecting member with a split portion is used to connect leaflets of the pliant material to the support beams, the split connecting member compressing the pliant material in position.

[0084] Furthermore, in accordance with another preferred  
10 embodiment of the present invention, a portion of the connecting member is perpendicular to the split portion.

[0085] Furthermore, in accordance with another preferred  
embodiment of the present invention, the support frame is provided with  
metallic members coupled to the stent and rigid members are positioned  
15 on two opposite sides of the metallic member and held against each other holding portion of the pliant material between them, sutured, the metallic members wrapped with PET.

[0086] Furthermore, in accordance with another preferred  
embodiment of the present invention, the device is further provided with  
20 spring in order to reduce wear of the pliant material.

[0087] Furthermore, in accordance with another preferred  
embodiment of the present invention, the spring is provided with a spiral.

[0088] Furthermore, in accordance with another preferred  
embodiment of the present invention, the spring is made from stainless  
25 steel.

[0089] Furthermore, in accordance with another preferred embodiment of the present invention, the spring is attached to slots provided on the support frames.

[0090] Furthermore, in accordance with another preferred  
5 embodiment of the present invention, the pliant material is sutured to the support frame forming pockets.

[0091] Furthermore, in accordance with another preferred  
embodiment of the present invention, attachment bars are provided on the  
stent support at a portion of the stent close to the outlet, onto which the  
10 pliant material is coupled, and wherein the pliant material is attached  
circumferentially to the inlet, leaving slack pliant material.

[0092] Furthermore, in accordance with another preferred  
embodiment of the present invention, the outlet is tapered with respect to  
the inlet.

[0093] Furthermore, in accordance with another preferred  
15 embodiment of the present invention, the support frame at the outlet is  
wider in diameter than the pliant material forming the outlet.

[0094] Furthermore, in accordance with another preferred  
embodiment of the present invention, the pliant material is reinforced  
20 using PET.

[0095] Furthermore, in accordance with another preferred  
embodiment of the present invention, the support frame is a tube having  
an inner wall, having sinusoidal fold lines, wherein the pliant material is  
sutured to the inner wall of the tube along suture lines.

[0096] Furthermore, in accordance with another preferred embodiment of the present invention, additional piece of PET is added below the suture lines.

[0097] Furthermore, in accordance with another preferred  
5 embodiment of the present invention, the device is incorporated with an angioplasty balloon.

[0098] Finally, in accordance with another preferred embodiment of the present invention, balloon has a central longitudinal axis that runs along a flow path through the device, and a perimeter, the balloon  
10 comprising four inflatable portions, one portion located along a central axis and the other three located on the perimeter, the pliant material in the form of leaflets is distributed about the perimeter.

#### BRIEF DESCRIPTION OF THE FIGURES

[0099] To better understand the present invention and appreciate its  
15 practical applications, the following Figures are provided and referenced hereafter. It should be noted that the Figures are given as examples only and in no way limit the scope of the invention as defined in the appended claims.

[00100] Figure 1 represents an oblique view of an embodiment of  
20 the invention:

[00101] Figure 2 represents a cross-sectional view across line 2-2 of the embodiment shown in Figure 1;

[00102] Figure 3 represents an oblique, partly cross-sectional view of another embodiment of the invention; and

[00103] Figure 4 represents a cross-sectional view across line 4-4 of the embodiment shown in Figure 3.

#### DETAILED DESCRIPTION OF THE INVENTION

[00104] A main aspect of the present invention is the introduction of several novel designs for an implantable prosthetic valve. Another aspect of the present invention is the disclosure of several manufacturing methods for implantable prosthetic valves in accordance with the present invention. A further aspect of the present invention is the provision of novel deployment and positioning techniques suitable for the valve of the present invention.

[00105] Basically the implantable prosthetic valve of the present invention comprises a leaflet-valve assembly, preferably tricuspid but not limited to tricuspid valves only, consisting of a conduit having an inlet end and an outlet, made of pliant material arranged so as to present collapsible walls at the outlet. The valve assembly is mounted on a support structure or frame such as a stent adapted to be positioned at a target location within the body duct and deploy the valve assembly by the use of deploying means, such as a balloon catheter or similar devices. In embodiments suitable for safe and convenient percutaneous positioning and deployment the annular frame is able to be posed in two positions, a crimped position where the conduit passage cross-section presented is small so as to permit advancing the device towards its target location, and a deployed position where the frame is radial extended by forces exerted from within (by deploying means) so as to provide support against the body duct wall, secure the valve in position and open itself so as to allow flow through the conduit.

- [00106] The valve assembly can be made from biological matter, such as a natural tissue, pericardial tissue or other biological tissue. Alternatively, the valve assembly may be made from biocompatible polymers or similar materials. Homograph biological valves need occasional replacement (usually within 5 to 14 years), and this is a consideration the surgeon must take into account when selecting the proper valve implant according to the patient type. Mechanical valves, which have better durability qualities, carry the associated risk of long-term anticoagulation treatment.
- 5
- 10 [00107] The frame can be made from shape memory alloys such as nickel titanium (nickel titanium shape memory alloys, or NiTi, as marketed, for example, under the brand name Nitinol), or other biocompatible metals. The percutaneously implantable embodiment of the implantable valve of the present invention has to be suitable for crimping into a narrow configuration for positioning and expandable to a wider, deployed configuration so as to anchor in position in the desired target location.
- 15
- [00108] The support stent is preferably annular, but may be provided in other shapes too, depending on the cross-section shape of the desired target location passage.
- 20
- [00109] Manufacturing of the implantable prosthetic valve of the present invention can be done in various methods, by using pericardium or, for example, by using artificial materials made by dipping, injection, electrospinning, rotation, ironing, or pressing.
- 25 [00110] The attachment of the valve assembly to the support stent can be accomplished in several ways, such as by sewing it to several

anchoring points on the support frame or stent, or riveting it, pinning it, adhering it, or welding it, to provide a valve assembly that is cast or molded over the support frame or stent, or use any other suitable way of attachment.

5 [00111] To prevent leakage from the inlet it is optionally possible to roll up some slack wall of the inlet over the edge of the frame so as to present rolled-up sleeve-like portion at the inlet.

[00112] Furthermore, floating supports may be added to enhance the stability of the device and prevent it from turning inside out.

10 [00113] An important aspect of certain embodiments of the present invention is the provision of rigid support beams incorporated with the support stent that retains its longitudinal dimension while the entire support stent may be longitudinally or laterally extended.

[00114] The aforementioned embodiments as well as other  
15 embodiments, manufacturing methods, different designs and different types of devices are discussed and explained below with reference to the accompanying drawings. Note that the drawings are only given for the purpose of understanding the present invention and presenting some preferred embodiments of the present invention, but this does in no way  
20 limit the scope of the present invention as defined in the appended claims.

[00115] Figures 1 and 2 illustrate a general tricuspid implantable prosthetic valve 10 in accordance with a preferred embodiment of the present invention, suitable for percutaneous deployment using an expandable stent or similar deploying means, shown in its deployed  
25 position. Valve 10 comprises a valve assembly 20 having an inlet 22 and

an outlet 24, the outlet walls consisting of collapsible pliant leaflet material 26 that is arranged to collapse in a tricuspid arrangement. Valve assembly 20 is attached to an annular support stent 32, the one in this figure being a net-like frame designed to be adapted to crimp evenly so as to present a narrow configuration and be radially deployable so as to extend to occupy the passage at the target location for implantation in a body duct. Support beams 34 are provided on annular support stent 32 to provide anchorage to valve assembly 20. Support beams 34 are optionally provided with bores 36 to allow stitching of valve assembly 20 to support beams 34 by thread, wire, or other attachment means.

[00116] The proximal portion 38 of support stent 32 is snugly fit or fastened to the proximal portion of valve assembly 20 so that any flow is only into inlet 22. Optionally the radial sections of each leaflet 26 is closed by stitching, gluing or other means to narrow outlet 24. The distal portion 42 of support stent 32 is narrower than proximal portion 38. The combination of the effect on flow characteristics due to the narrowing of support stent 32 and the narrowing of outlet 24 is sufficient to engender the desired effect or flow characteristics, namely, non-laminar retrograde flow that will assist in the closing of leaflets 26.

[00117] Another embodiment of the invention is shown in Figures 3 and 4. A prosthetic valve 50 comprises a valve assembly 52 positioned within a support stent 54. The proximal 56 and distal 58 portions of support stent 54 are narrow as compared to the mid-portion 60 of support stent 54, where valve assembly 52 is positioned. Within support stent mid-portion 60 valve assembly 52 is preferably positioned co-axially and at a small distance, for example, from 0.5 to 3 cm, from the interior surface 64 of support stent 54. Valve assembly 52 is attached by



connecting membrane 66 to stent supports 68, which optimally have holes or projections 70 to anchor said membranes 66. Any annular space between interior surface 64 and valve assembly 54 is filled with appropriate material to prevent flow around valve assembly 54. Valve  
5 leaflets are shown in closed 72 and open 74 positions.

**[00118]** Valve assembly 54 is shown in a closed position wherein leaflets 70 inhibit flow.

**[00119]** The effective cross-sectional area of valve assembly 54 will preferably be from about 40 to 80% of the cross-sectional area across  
10 support stent midsection 60.

**[00120]** The preferred embodiments representing an implantable prosthetic valve in accordance with the present invention are relatively easy to manufacture as they are generally flat throughout most of the production process and only at the final stage of mounting the other  
15 elements of the valve assembly on the support frame, a three dimensional form is established.

**[00121]** A typical size of an aortic prosthetic valve is from about 19 to about 26 mm in diameter. A maximal size of a catheter inserted into the femoral artery should be no more than 9 mm in diameter. The present  
20 invention introduces a device, which has the ability to change its diameter from about 4 mm to about 26 mm. Artificial valves are not new; however, artificial valves in accordance with the present invention possess the ability to change shape and size for the purpose of delivery and as such are novel. These newly designed valves require new manufacturing  
25 methods and technical inventions and improvements, some of which were described herein.

[00122] As mentioned earlier, the material of which the valve is made from can be either biological or artificial. In any case new technologies are needed to create such a valve.

[00123] To attach the valve to the body, the blood vessels determine the size during delivery, and the requirements for it to work efficiently, there is a need to mount it on a collapsible construction which can be crimped to a small size, be expanded to a larger size, and be strong enough to act as a support for the valve function. This construction, which is in somewhat similar to a large "stent", can be made of different materials such as Nitinol, biocompatible stainless steel, polymeric material or a combination of all. Special requirement for the stent are a subject of some of the embodiments discussed herein.

[00124] The mounting of the valve onto a collapsible stent is a new field of problems. New solutions to this problem are described herein.

[00125] Another major aspect of the design of the valve of the present invention is the attachment to the body.

[00126] In the traditional procedure the valve is sutured in place by a complicated suturing procedure. In the case of the percutaneous procedure there is no direct access to the implantation site therefore different attachment techniques are needed.

[00127] Another new problem that is dealt herein is the delivery procedure, which is new and unique. Positioning of the device in the body in an accurate location and orientation requires special marking and measuring methods of the device and surgical site as was disclosed herein.

**[00128]** Artificial polymer valves require special treatment and special conditions when kept on a shelf, as well as a special sterilization procedure. One of the consequences of the shelf treatment is the need to crimp the valve during the implantation procedure. A series of devices  
5 and inventions to allow the crimping procedure are disclosed herein.

**[00129]** It should be clear that the description of the embodiments and attached Figures set forth in this specification serves only for a better understanding of the invention, without limiting its scope as covered by the following claims.

10 **[00130]** It should also be clear that a person skilled in the art, after reading the present specification could make adjustments or amendments to the attached Figures and above described embodiments that would still be covered by the following claims.

## CLAIMS

[00131] 1. A valve prosthesis device suitable for implantation in corporeal ducts, the device comprising:

[00132] a support stent, and

5 [00133] a valve assembly comprising a flexible conduit having an inlet end and an outlet end,

[00134] wherein when flow is allowed to pass through the valve prosthesis device from the inlet to the outlet, the valve assembly is kept in an open position; wherein a reverse flow is prevented as the  
10 collapsible slack portions of the valve assembly collapse inwardly providing blockage to the reverse flow; and where the device is configured so that retrograde flow will be altered from laminar flow and directed towards the leaflets to effect closing .

[00135] 2. The valve prosthesis device of Claim 1, wherein the  
15 support stent comprises a deployable construction adapted to be initially crimped in a narrow configuration suitable for catheterization through the body duct to a target location and adapted to be deployed by exerting substantially radial forces from within by means of a deployment device to a deployed state in the target location

20 [00136] 3. The valve prosthesis device of Claim 1, wherein the support stent is provided with a plurality of longitudinally rigid support beams of fixed length.

[00137] 4. The valve prosthesis device of Claim 1, wherein the valve assembly comprises pliant material attached to the support beams and provides collapsible slack portions of the conduit at the outlet.

[00138] 5. The valve prosthesis of Claim 1, wherein the device  
5 is configured so that an artificial sinus is formed adjacent to the valve assembly.

[00139] 6. The valve prosthesis of Claim 1, wherein the retrograde flow will be substantially non-laminar.

[00140] 7. A valve prosthesis device suitable for implantation in  
10 corporeal ducts, the device comprising:

[00141] a support stent, comprised of a deployable construction adapted to be initially crimped in a narrow configuration suitable for catheterization through the body duct to a target location and adapted to be deployed by exerting substantially radial forces from within  
15 by means of a deployment device to a deployed state in the target location, the support stent provided with a plurality of longitudinally rigid support beams of fixed length; and

[00142] a valve assembly comprising a flexible conduit having an inlet end and an outlet, made of pliant material attached to the  
20 support beams providing collapsible slack portions of the conduit at the outlet,

[00143] wherein when flow is allowed to pass through the valve prosthesis device from the inlet to the outlet, the valve assembly is kept in an open position, wherein a reverse flow is prevented as the  
25 collapsible slack portions of the valve assembly collapse inwardly

providing blockage to the reverse flow, and wherein the device is configured so that retrograde flow will be altered from laminar flow and directed towards the leaflets to effect closing ..

[00144] 8. The valve prosthesis device of Claim 7, wherein the  
5 support stent comprises an annular frame.

[00145] 9. The valve prosthesis device of Claim 7, wherein said valve assembly has a tricuspid configuration.

[00146] 10. The valve prosthesis device of Claim 7, wherein said valve assembly is made from biocompatible material.

10 [00147] 11. The valve prosthesis device of Claim 10, wherein the valve assembly is made from pericardial tissue, or other biological tissue.

[00148] 12. The valve prosthesis device of Claim 7, wherein said valve assembly is made from biocompatible polymers.

15 [00149] 13. The valve prosthesis device of Claim 12, wherein the valve assembly is made from materials selected from polyurethane and polyethylene terephthalate.

[00150] 14. The valve prosthesis device of Claim 13, wherein said valve assembly comprises a main body made from polyethylene terephthalate and leaflets made from polyurethane.

20 [00151] 15. The valve prosthesis device of Claim 7, wherein said support stent is made from nickel titanium.

[00152] 16. The valve prosthesis device of Claim 7, wherein the support beams are substantially equidistant and substantially parallel so as to provide anchorage for the valve assembly.

[00153] 17. The valve prosthesis device of Claim 7, wherein the  
5 support beams are provided with bores so as to allow stitching or tying of the valve assembly to the beams.

[00154] 18. The valve prosthesis device of Claim 7, wherein the support beams are chemically adhered to the support stent.

[00155] 19. The valve prosthesis device of Claim 7, wherein said  
10 valve assembly is riveted to the support beams.

[00156] 20. The valve prosthesis device of Claim 7, wherein said valve assembly is stitched to the support beams.

[00157] 21. The valve prosthesis device of Claim 7, wherein said beams are manufactured by injection using a mold, or by machining.

[00158] 22. The valve prosthesis device of Claim 7, wherein said  
15 valve assembly is rolled over the support stent at the inlet.

[00159] 23. The valve prosthesis device of Claim 7, wherein said valve device is manufactured using forging or dipping techniques.

[00160] 24. The valve prosthesis device of Claim 7, wherein said  
20 valve assembly leaflets are longer than needed to exactly close the outlet, thus when they are in the collapsed state substantial portions of the leaflets fall on each other creating better sealing.

[00161] 25. The valve prosthesis device of Claim 7, wherein said valve assembly is made from a coiled polymer, coated by a coating layer of the same polymer.

[00162] 26. The valve prosthesis device of Claim 25, wherein  
5 said polymer is polyurethane.

[00163] 27. The valve prosthesis device of Claim 7, wherein the support stent is provided with heavy metal markers so as to enable tracking and determining the valve device position and orientation.

[00164] 28. The valve prosthesis device of Claim 27, wherein the  
10 heavy metal markers are selected from the group consisting of gold, platinum-iridium, and tantalum.

[00165] 29. The valve prosthesis device of Claim 7, wherein the valve assembly leaflets are provided with radio-opaque material at the outlet, so as to help tracking the valve device operation in vivo.

[00166] 30. The valve prosthesis device of Claim 29, wherein  
15 said radio-opaque material comprises gold thread.

[00167] 31. The valve prosthesis device of Claim 7, wherein the diameter of said support stent, when fully deployed is in the range of from about 19 to about 26 mm.

[00168] 32. The valve prosthesis device of Claim 7, wherein the  
20 diameter of said support stent may be expanded from about 4 to about 26 mm.

[00169] 33. The valve prosthesis device of Claim 7, wherein the support beams are provided with bores and wherein the valve assembly is



attached to the support beams by means of U-shaped rigid members that are fastened to the valve assembly and that are provided with extruding portions that fit into matching bores on the support beams.

[00170] 34. The valve prosthesis device of Claim 7, wherein the  
5 support beams comprise rigid support beams in the form of frame construction, and the valve assembly pliant material is inserted through a gap in the frame and a fastening rod is inserted through a pocket formed between the pliant material and the frame and holds the valve in position.

[00171] 35. The valve prosthesis device of Claim 7, wherein the  
10 main body of the valve assembly is made from coiled wire coated with a coating material.

[00172] 36. The valve prosthesis device of Claim 35, wherein the coiled wire and the coating material is made from polyurethane.

[00173] 37. The valve prosthesis device of Claim 7, wherein a  
15 strengthening wire is interlaced in the valve assembly at the outlet of the conduit so as to define a fault line about which the collapsible slack portion of the valve assembly may flap.

[00174] 38. The valve prosthesis device of Claim 37, wherein the strengthening-wire is made from nickel titanium alloy.

20 [00175] 39. A valve prosthesis device suitable for implantation in corporeal ducts, the device comprising a main conduit body having an inlet and an outlet and pliant leaflets attached at the outlet so that when flow passes through the conduit from the inlet to the outlet the leaflets are in an open position allowing the flow to exit the outlet, and when the flow  
25 is reversed the leaflets collapse so as to block the outlet, wherein the main

body is made from polyethylene terephthalate and collapsible leaflets are made from polyurethane and wherein the device is configured so that retrograde flow will be altered from laminar flow and directed towards the leaflets to effect closing.

5 [00176] 40. The valve prosthesis device of Claim 39, wherein support beams made from polyurethane are provided on the main body and wherein the leaflets are attached to the main body at the support beams.

[00177] 41. The valve prosthesis device of Claim 39, wherein  
10 said support beams are chemically adhered to the main body.

[00178] 42. A valve prosthesis device suitable for implantation in corporeal ducts, the device comprising:

[00179] a support stent, comprised of a deployable construction adapted to be initially crimped in a narrow configuration  
15 suitable for catheterization through the body duct to a target location and adapted to be deployed by exerting substantially radial forces from within by means of a deployment device to a deployed state in the target location, the support stent provided with a plurality of longitudinally rigid support beams of fixed length;

20 [00180] a valve assembly comprising a flexible conduit having an inlet end and an outlet, made of pliant material attached to the support beams providing collapsible slack portions of the conduit at the outlet; and

[00181] substantially equidistant rigid support beams interlaced or attached to the slack portion of the valve assembly material, arranged longitudinally,

[00182] wherein the device is configured so that retrograde  
5 flow will be altered from laminar flow and directed towards the leaflets to effect closing .

[00183] 43. A valve prosthesis device suitable for implantation in corporeal ducts, the device comprising:

[00184] an expandable support frame, the support frame  
10 provided with a plurality of longitudinally rigid support beams of fixed length; and

[00185] a valve assembly comprising a flexible conduit having an inlet end and an outlet, made of pliant material attached to the support beams providing collapsible slack portions of the conduit at the  
15 outlet,

[00186] wherein when flow is allowed to pass through the valve prosthesis device from the inlet to the outlet, the valve assembly is kept in an open position, wherein a reverse flow is prevented as the collapsible slack portions of the valve assembly collapse inwardly  
20 providing blockage to the reverse flow, and wherein the device is configured so that retrograde flow will be altered from laminar flow and directed towards the leaflets to effect closing .

[00187] 44. The valve prosthetic device of Claim 43, wherein the expandable support frame comprises a deployable construction adapted to  
25 be initially crimped in a narrow configuration suitable for catheterization

through the corporeal duct to a target location and adapted to be deployed by exerting substantially radial forces from within by means of a deployment device to a deployed state in the target location.

5 [00188] 45. The valve prosthetic device of Claim 43, wherein the support beams have a U-shaped cross section.

[00189] 46. The valve prosthetic device of Claim 45, wherein a holder is used to secure the pliant material to the support beams.

10 [00190] 47. The valve prosthetic device of Claim 43, wherein the support frame comprises three segments that form a circular assembly when assembled.

[00191] 48. The valve prosthetic device of Claim 43, wherein the support beams point inwardly with respect to a central longitudinal axis of the device.

15 [00192] 49. The valve prosthetic device of Claim 47, wherein the support beams point outwardly with respect to a central longitudinal axis of the device.

[00193] 50. The valve prosthetic device of Claim 43, further provided with a restricting tapered housing, for housing it in a crimped state

20 [00194] 51. The valve prosthetic device of Claim 43, wherein hooks are provided to secure the device in position after it is deployed.

[00195] 52. The valve prosthetic device of Claim 43, wherein the support beams comprise longitudinal bars having a narrow slit used as the

commissural attachment so that extensions the pliant material are tightly inserted through it.

[00196] 53. The valve prosthetic device of Claim 52, wherein the extensions of the pliant material are wrapped about rigid bars serving as  
5 anchorage means.

[00197] 54. The valve prosthetic device of Claim 53, wherein extensions of the pliant material are sutured to each other at the rigid bars.

[00198] 55. The valve prosthetic device of Claim 54, wherein a bottom portion of the pliant material is attached to the inlet.

10 [00199] 56. The valve prosthetic device of Claim 43, wherein the support beams are each provided with a rounded pole, forming a loop through which the pliant material is inserted.

[00200] 57. The valve prosthetic device of Claim 43, wherein the pliant material is provided with longitudinal bars attached to the pliant  
15 material at positions assigned for attachment to the support frame, in order to prevent localized stress from forming.

[00201] 58. The valve prosthetic device of Claim 43, further provided with longitudinal bars having protrusions that are inserted in bores in the pliant material, a sheet of PET and through bores provided on  
20 the support beams.

[00202] 59. The valve prosthetic device of Claim 43, wherein the pliant material is sutured leaving the slack portions free of sutures.

[00203] 60. The valve prosthetic device of Claim 43, wherein a connecting member with a split portion is used to connect leaflets of the

pliant material to the support beams, the split connecting member compressing the pliant material in position.

[00204] 61. The valve prosthetic device of Claim 60, wherein a portion of the connecting member is perpendicular to the split portion.

5 [00205] 62. The valve prosthetic device of Claim 43, wherein the support frame is provided with metallic members coupled to the stent and rigid members are positioned on two opposite sides of the metallic member and held against each other, holding a portion of the pliant material between them, sutured, the metallic members wrapped with PET.

10 [00206] 63. The valve prosthetic device of Claim 3, wherein the device is further provided with spring to reduce wear of the pliant material.

[00207] 64. The valve prosthetic device of Claim 63, wherein the spring is provided with a spiral.

15 [00208] 65. The valve prosthetic device of Claim 63, wherein the spring is made from stainless steel.

[00209] 66. The valve prosthetic device of Claim 63, wherein the spring is attached to slots provided on the support frame.

[00210] 67. The valve prosthetic device of Claim 43, wherein the  
20 pliant material is sutured to the support frame forming pockets.

[00211] 68. The valve prosthetic device of Claim 67, wherein attachment bars are provided on the stent support at a portion of the stent close to the outlet, on which the pliant material is coupled to, and wherein the pliant material is attached circumferentially to the inlet, leaving slack  
5 pliant material.

[00212] 69. The valve prosthetic device of Claim 43, wherein the outlet is tapered with respect to the inlet.

[00213] 70. The valve prosthetic device of Claim 69, wherein the support frame at the outlet is wider in diameter than the pliant material  
10 forming the outlet.

[00214] 71. The valve prosthetic device of Claim 43, wherein the pliant material is reinforced using PET.

[00215] 72. The valve prosthetic device of Claim 43, wherein the support frame is a tube having an inner wall, having sinusoidal fold lines,  
15 wherein the pliant material is sutured to the inner wall of the tube along suture lines.

[00216] 73. The valve prosthetic device of Claim 72, wherein additional piece of PET is added below the suture lines.

[00217] 74. The valve prosthetic device of Claim 43, wherein the  
20 device is incorporated with an angioplasty balloon.

[00218] 75. The valve prosthetic device of Claim 74, wherein the balloon has a central longitudinal axis that runs along a flow path through the device, and a perimeter, the balloon comprising four inflatable portions, one portion located along a central axis and the other three

located on the perimeter, the pliant material in the form of leaflets is distributed about the perimeter.



1/2

FIG. 1

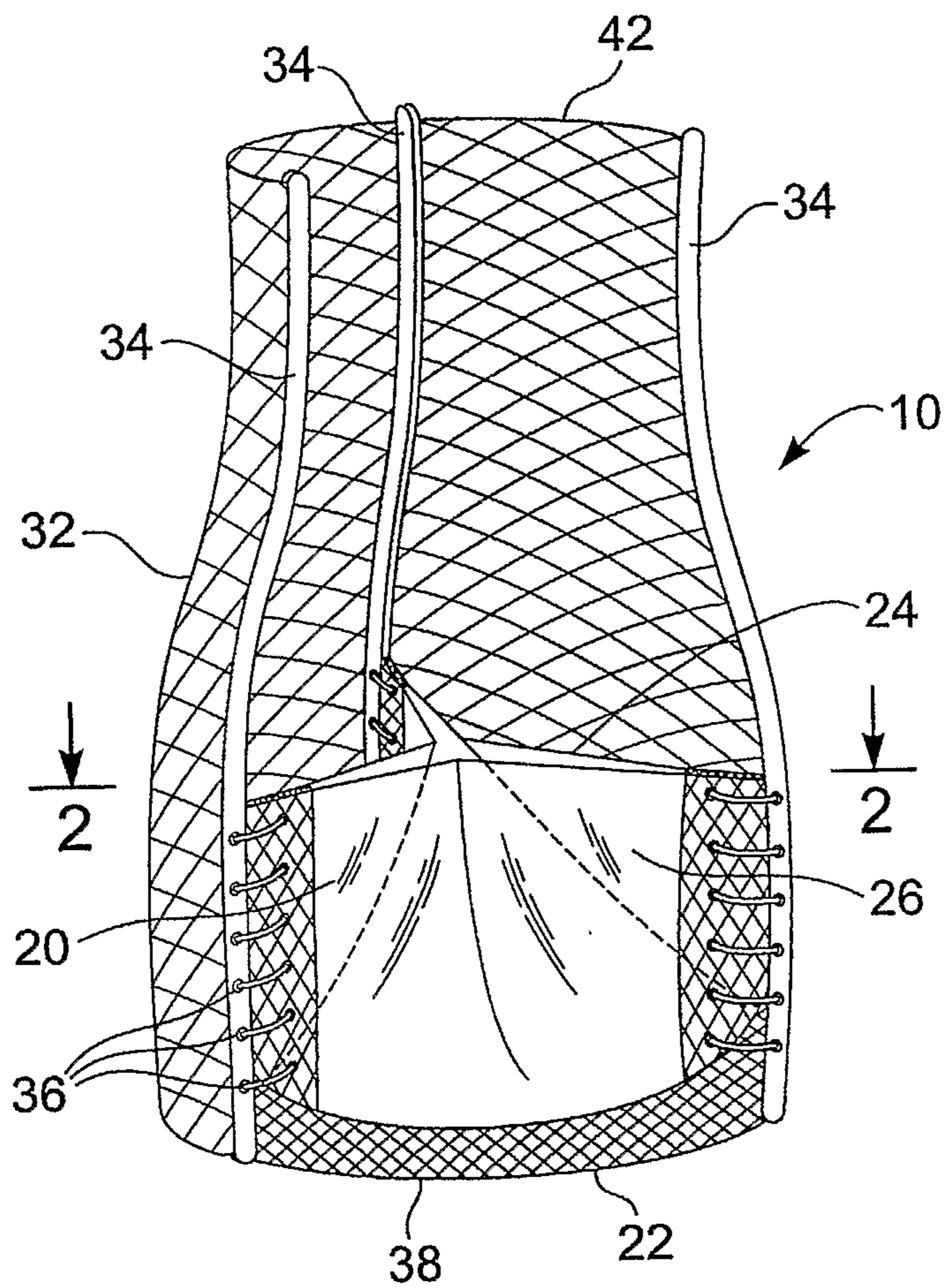
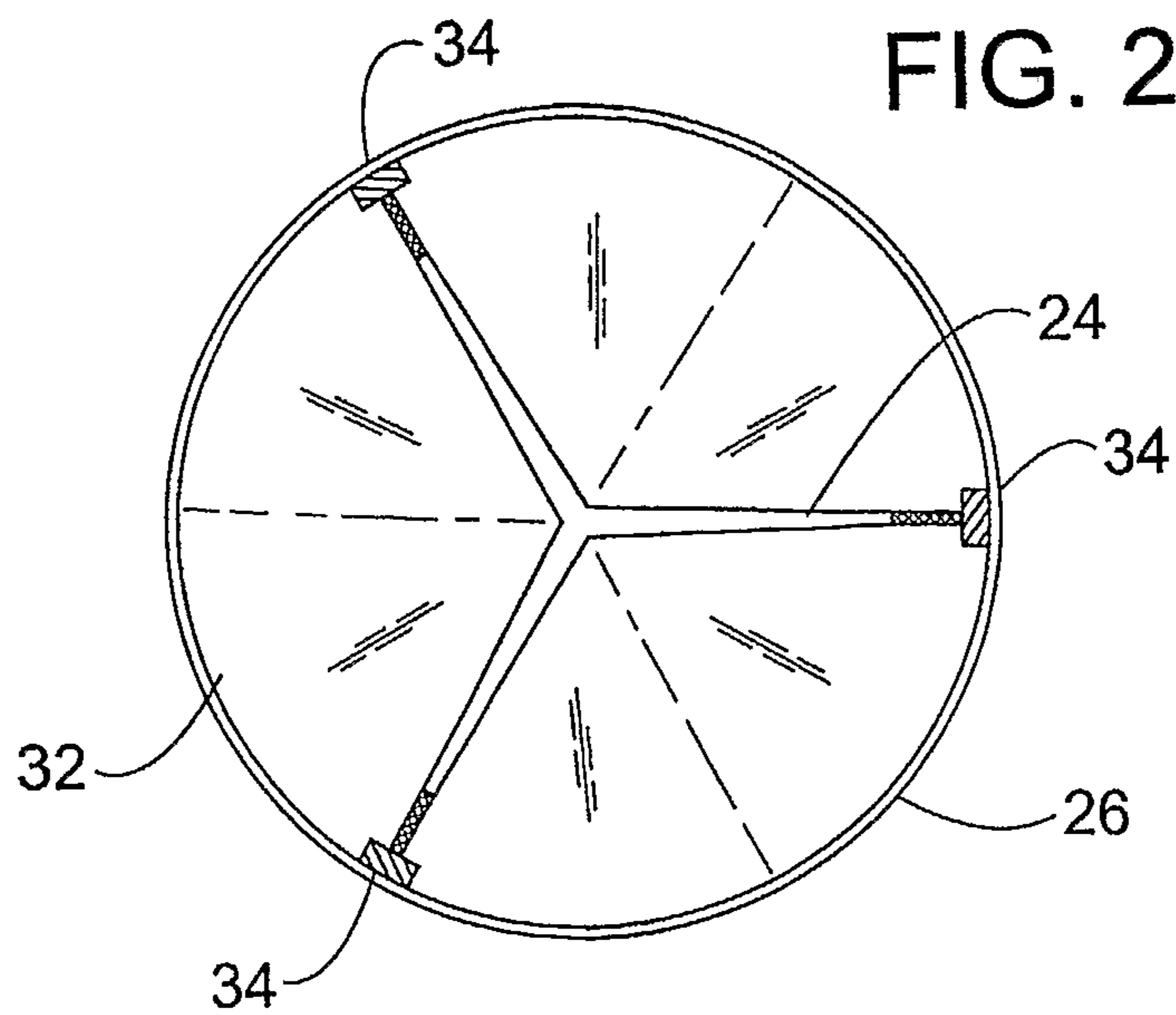

FIG. 2



2/2

FIG. 3

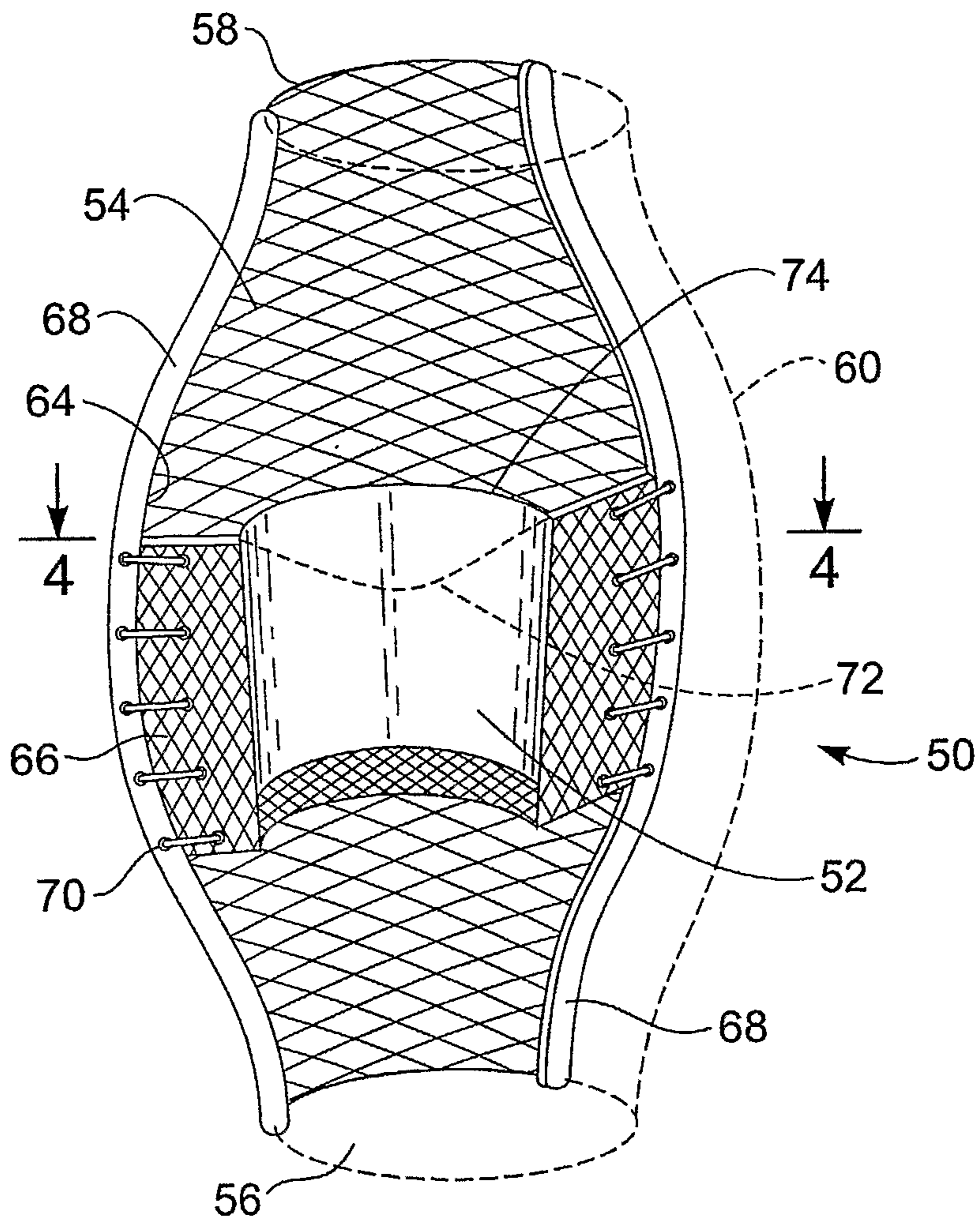

FIG. 4

