



- (51) **International Patent Classification:**
H01L 33/62 (2010.01) H01L 33/60 (2010.01)
H01L 33/48 (2010.01)
- (21) **International Application Number:**
PCT/US2018/041774
- (22) **International Filing Date:**
12 July 2018 (12.07.2018)
- (25) **Filing Language:** English
- (26) **Publication Language:** English
- (30) **Priority Data:**
15/652,603 18 July 2017 (18.07.2017) US
17184498.8 02 August 2017 (02.08.2017) EP
- (71) **Applicant:** LUMILEDS LLC [US/US]; 370 West Trimble Road, San Jose, California 95131 (US).
- (72) **Inventors:** LI, Shu; 370 West Trimble Road, San Jose, California 95131 (US). VU, Thuy; 5106 Pearl Avenue, San Jose, California 95136 (US).
- (74) **Agent:** KELLNER, Steven M.; Volpe & Koenig, P.C., 30 South 17th Street, Suite 1800, Philadelphia, Pennsylvania 19103 (US).
- (81) **Designated States** (*unless otherwise indicated, for every kind of national protection available*): AE, AG, AL, AM, AO, AT, AU, AZ, BA, BB, BG, BH, BN, BR, BW, BY, BZ, CA, CH, CL, CN, CO, CR, CU, CZ, DE, DJ, DK, DM, DO, DZ, EC, EE, EG, ES, FI, GB, GD, GE, GH, GM, GT, HN, HR, HU, ID, IL, IN, IR, IS, JO, JP, KE, KG, KH, KN, KP, KR, KW, KZ, LA, LC, LK, LR, LS, LU, LY, MA, MD, ME, MG, MK, MN, MW, MX, MY, MZ, NA, NG, NI, NO, NZ, OM, PA, PE, PG, PH, PL, PT, QA, RO, RS, RU, RW, SA, SC, SD, SE, SG, SK, SL, SM, ST, SV, SY, TH, TJ, TM, TN, TR, TT, TZ, UA, UG, US, UZ, VC, VN, ZA, ZM, ZW.
- (84) **Designated States** (*unless otherwise indicated, for every kind of regional protection available*): ARIPO (BW, GH, GM, KE, LR, LS, MW, MZ, NA, RW, SD, SL, ST, SZ, TZ, UG, ZM, ZW), Eurasian (AM, AZ, BY, KG, KZ, RU, TJ, TM), European (AL, AT, BE, BG, CH, CY, CZ, DE, DK, EE, ES, FI, FR, GB, GR, HR, HU, IE, IS, IT, LT, LU, LV, MC, MK, MT, NL, NO, PL, PT, RO, RS, SE, SI, SK, SM,

(54) **Title:** LIGHT EMITTING DEVICE INCLUDING A LEAD FRAME AND AN INSULATING MATERIAL

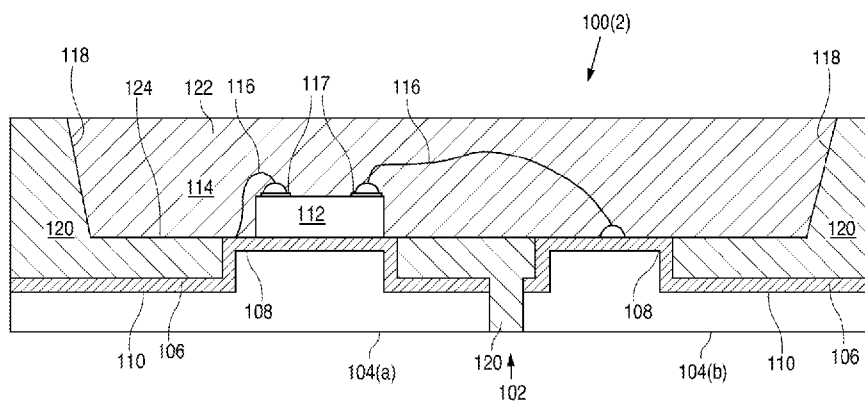

FIG. 2

(57) **Abstract:** A package for a light emitting diode (LED) may include a lead frame, an LED, and an optically reflective but electrically non-conductive molding. The lead frame may have a first lead frame part and a second lead frame part electrically isolated from the first lead frame part. Each lead frame part may have at least one raised pillar. The molding may be disposed over the lead frame except over the pillars of the lead frame. The LED may be mounted on at least one pillar and is electrically coupled to at least one pillar. The molding may serve the purpose of a highly reflective, electrically conductive material like silver without being subject to tarnishing.



TR), OAPI (BF, BJ, CF, CG, CI, CM, GA, GN, GQ, GW,
KM, ML, MR, NE, SN, TD, TG).

Published:

— *with international search report (Art. 21(3))*

LIGHT EMITTING DEVICE INCLUDING A LEAD FRAME AND AN INSULATING MATERIAL**CROSS REFERENCE TO RELATED APPLICATIONS**

[0001] This application claims the benefit of U.S. Patent Application No. 15/652,603, filed on July 18, 2017, and EP Patent Application No. 17184498.8, filed on August 2, 2017, the contents of which are hereby incorporated by reference herein.

BACKGROUND

[0002] Light emitting diodes (“LEDs”) are solid state devices that emit light when provided with an electrical current. LEDs are packaged in a relatively complex encasement incorporating different materials to provide various functions for the LED. One component typically used in a package is a layer of silver. The silver provides good electrical conductivity to the LED semiconductor device while also providing good optical characteristics such as high reflectivity and reflectivity of light at appropriate wavelengths. However, silver is subject to tarnishing, even when covered by an encapsulation material.

SUMMARY

[0003] A light emitting diode (LED) package may include a lead frame comprising a first lead frame part electrically isolated from a second lead frame part. The first lead frame part may include a first pillar that is raised above a lower surface of the first lead frame part. The second lead frame part may include a second pillar that is raised above a lower surface of the second lead frame part. A molding may cover the lower surfaces of the lead frame parts. At least a portion of the first pillar and the second pillar may remain exposed. The molding may comprise a highly optically reflective and electrically insulating material. An LED device may be disposed over only the second pillar. A first contact may be formed on the LED device. The first contact may be electrically coupled to the first pillar via a first wire bond. A second contact may be formed on the LED device. The second contact may be electrically coupled to the second pillar via a second wire bond.

BRIEF DESCRIPTION OF THE DRAWINGS

[0004] A more detailed understanding may be had from the following description, given by way of example in conjunction with the accompanying drawings, wherein like reference numerals in the figures indicate like elements, and wherein:

[0005] Figure 1 is a cross sectional view of an LED package, according to an example;

[0006] Figures 2 and 3 illustrate alternative configurations for the LED package, according to examples; and

[0007] Figures 4-8 illustrate an exploded view of, and method of manufacturing, an LED package, according to an example.

DETAILED DESCRIPTION

[0008] Examples of different light emitting diode ("LED") implementations will be described more fully hereinafter with reference to the accompanying drawings. These examples are not mutually exclusive, and features found in one example can be combined with features found in one or more other examples to achieve additional implementations. Accordingly, it will be understood that the examples shown in the accompanying drawings are provided for illustrative purposes only and they are not intended to limit the disclosure in any way. Like numbers refer to like elements throughout.

[0009] It will be understood that, although the terms first, second, etc. may be used herein to describe various elements, these elements should not be limited by these terms. These terms are only used to distinguish one element from another. For example, a first element could be termed a second element, and, similarly, a second element could be termed a first element, without departing from the scope of the present description. As used herein, the term "and/or" includes any and all combinations of one or more of the associated listed items.

[0010] It will be understood that when an element such as a layer, region or substrate is referred to as being "on" or extending "onto" another element, it can be directly on or extend directly onto the other element or intervening elements may also be present. In contrast, when an element is referred to as being "directly on" or extending "directly onto" another element, there are no intervening elements present. It will also be understood that when an element is referred to as being "connected" or "coupled" to another element, it can be directly connected or coupled to the other element or intervening elements may be present. In contrast, when an element is referred to as being "directly connected" or "directly coupled" to another element, there are no intervening elements present. It will be understood that these terms are intended to encompass different orientations of the element in addition to any orientation depicted in the figures.

[0011] Relative terms such as "below" or "above" or "upper" or "lower" or "horizontal" or "vertical" may be used herein to describe a relationship of one element, layer or region to another element, layer or region as illustrated in the figures. It will be understood that these terms are intended to encompass different orientations of the device in addition to the orientation depicted in the figures.

[0012] A package is provided herein with physical characteristics that reduce the necessity for the use of silver, which, while having good optical qualities such as reflectivity, is susceptible to being tarnished by environmental agents. More specifically, silver has a high affinity to materials such as hydrogen sulfide, halogens, oxygen, water vapor, nitrous oxide, sulfur dioxide, and ozone, which may be found in polluted air, especially in city centers or industrial areas. These materials may result in the formation of black silver sulfide or dark yellow silver oxide (known as silver tarnish), which may significantly and rapidly reduce the reflectivity of the silver.

[0013] The package includes a metal lead frame, a molding material disposed at least partially over the lead frame and forming a well in which light emitting diode ("LED") components are disposed, and an encapsulation material disposed within the well. The metal lead frame includes pillars on which an LED or other components are disposed and/or that serve as electrical contact points to form an electrical circuit that includes the lead frame and components within the well. Areas of the lead frame other than the pillars are covered by the molding, which is optically reflective. The top surface of the molding material within the well is flush with (or approximately flush with) the top surface of the pillars (or the top surface of any additional layers, such as a plated metal layer or the like, formed over the pillars), to form a single flush bottom surface of the well. The molding material is a highly reflective material to reflect light from the LED and provide good optical characteristics for the LED package. The lead frame configuration having raised pillars allows a more conventional material like silver to not be used in the LED package, or to be used less in the LED package, which alleviates the silver tarnishing problem. More specifically, while in conventional designs, silver would cover much of the bottom surface of the well, and thus would be subject to tarnishing, reducing the optical characteristics of the LED package, in the package of the present disclosure, the exposed surface virtually lacks silver, reflectivity being provided by the reflective molding material not subject to silver tarnishing.

[0014] Figure 1 is a cross sectional view of a package 100(1) according to an example. The package 100 includes a lead frame 102 that includes a first lead frame part 104(a) and a second lead frame part 104(b), the first lead frame part 104(a) being electrically isolated from the second lead frame part 104(b). The different lead frame parts 104 of the lead frame 102 provide electrical coupling between components within the package 100 and components external to the package. For example, one lead frame part 104 may couple to one terminal of an LED device 112 and to one external wire and another lead frame part 104 may couple to another terminal of the LED device 112 and to a different external wire, so that the LED device 112 is integrated into a circuit. A metal plating layer 106 is disposed over the first lead frame part 104(a) and the second lead frame part 104(b) in order to electrically couple various components, such as the LED 112, to the lead

frame 102. Though in conventional designs, a plating layer is made of silver so that the plating layer can perform double duty as both electrical conductor and optical reflector, in the present disclosure, the metal plating layer 106 does not need to be silver as the reflectivity of the LED package 100 is provided by the molding material 120. The metal plating layer 106 may be any technically feasible material other than silver, or may be silver.

[0015] The lead frame 102 has two raised portions or “pillars” 108 that extend above a lower surface 110 of the lead frame 102. The pillars 108 serve to provide points of electrical contact for electrical components (such as the LED 112) within a well 114. The well 114 is formed by side-walls 118 of a molding 120 made of a molding compound. The LED 112 is disposed on one of the pillars 108 and is electrically coupled, via a wire bond 116, to a pillar 108 of the second lead frame part 104(b). The LED 112 is also electrically coupled, via an electrically conductive contact 113, to the pillar 108 of the first lead frame part 104(a). The pillars 108 allow electrical connections to be formed between components within the well 114 and the lead frame 102 while minimizing the amount of exposed metal disposed, for example, over the lead frame 102. An encapsulant 122 is disposed over the components within the well 114 and fills the space of the well 114.

[0016] In a conventional lead frame design, two (or more) electrically isolated parts of a lead frame are plated with a metallic material such as silver which provides both electrical coupling to the lead frame and high optical reflectivity with good color characteristics of reflected light. Silver is very often used as a particularly good electrically conductive and optically reflective material in conventional designs. However, as described above, silver is subject to tarnishing even when covered by an encapsulation material. The lead frame 102 with pillars 108 of the present disclosure provides the function of allowing for electrical connection of components in the well 114 to the lead frame 102 while also allowing most of the bottom-most surface of the well 114 (which bottom-most surface is also called a “basin 124”) to be comprised not of silver but instead of a highly optically reflective non-electrically-conductive material. Note, the basin 124 is comprised of the top-most surfaces of the metal layer 106 and of the top-most surface of the molding 120 at the bottom of the well 114. Although illustrated as being a flush surface, the various portions of the basin 124 may be slightly or substantially uneven.

[0017] Figures 2 and 3 illustrate alternative configurations for the package 100, according to examples. More specifically, Figure 2 illustrates a package 100(2) in which the LED 112 is coupled to the lead frame 102 via two wire bonds 116 and Figure 3 illustrates a package 100(3) in which two contacts 119 on the bottom of the LED 112 couple the LED 112 to the lead frame 102. Figure 2 is a cross-sectional view of a package 100(2) according to another example. The package 100(2) is similar to the package 100(1) except that in the package 100(2), the LED 112 is coupled to

the lead frame 102 through two wire bonds 116 (which are coupled to the LED 112 through contacts 117) instead of through a contact 113 on the bottom of the LED 112 and a single wire bond 116. The LED 112 is mounted on to a pillar 108, but has no electrical coupling to the pillar through the bottom surface of the LED 112. Figure 3 is a cross-sectional view of a package 100(3) according to yet another example. In the package 100(3), the LED 112 is coupled to the lead frame 102 through two contacts 119 and without wire bonds 116. The LED 112 is mounted over both illustrated lead frame parts 104 to allow the two contacts 119 to be coupled to the two lead frame parts 104 while the LED 112 is directly over the two lead frame parts 104.

[0018] Although a specific configuration of components within the well 114 is shown, it should be understood that various configurations not illustrated are within the teachings of the present disclosure. The composition of the basin 124 varies depending on the shape, size, and number of pillars 108. In various embodiments, the basin 124 is mostly a non-conductive material, such as the material of the molding 120. In such embodiments, the basin 124 is 50% non-conductive material, 85% non-conductive material, or 95% non-conductive material. The portion of the basin 124 that is not the non-conductive material comprises the conductive material of the lead frame 102 and/or the metal layer 106.

[0019] In the example packages 100 illustrated above, the molding 120 comprises a highly reflective material. For example, the molding 120 comprises a silicone molding compound with high thermal, mechanical, electrical, and photochemical stability, such as, but not limited to, thermal set poly-siloxane and its derivative compounds. In various embodiments, the molding 120 is formed from an electrically insulating material such as plastic, thermoset material, thermoplastic material, polymer, epoxy polymer resin, composite materials based on silicone, composite molding compound silicone, polycyclohexylene, polycyclohexylene terephthalate, epoxy molding compound, liquid crystal polymers, mixtures thereof, or any other suitable material. The material forming the molding 120 may include fillers such as organic or inorganic materials. The fillers may adjust the physical properties of the material of molding 120 to improve the integrity and reliability of the material under application conditions of the LED device, and to achieve desired optical reflectivity for the molding 120. The material used for the molding 120 is durable, substantially non-yellowing, mechanically suitable, compatible with appropriate manufacturing processes, and highly reflective. Preferably, the molding 120 has a similar coefficient of thermal expansion as the lead frame 102, where "similar" means that the coefficients of thermal expansion are within 10% of each other. Although certain possible materials for the molding 120 are listed above, any suitable material may be used.

[0020] The metal plating layer 106 is illustrated disposed over the top surface of the lead frame 102, but in various examples, the metal plating layer 106 is disposed over only a portion of

the top surface of the lead frame 102, such as over the pillars 108. Further, the metal plating layer 106 may be any electrically conductive material. In some embodiments, the metal plating 106 and molding 120 that form the basin 124 are both materials that are stable at high temperature, stable at high doses of short wavelength (blue and UV) light, and inert to corrosive gases such as sulfur and/or its compounds, chlorine and/or its compounds, nitrogen oxides, ozone, water vapor, oxygen, and other pollutants in the environment of the intended applications of the LED 112. Although the lead frame 102 in the example packages 100 is illustrated as having a metal layer 106 disposed over the top surface to provide compatibility for wire bond 116 of Figures 1 and 2, or contacts 119 in Figure 3, as well as protection to the base metal of the lead frame 102. In some embodiments, no such metal layer 106 exists, for example, when such compatibility and/or protection are not required.

[0021] The lead frame, including the pillars 108, comprises a conductive material. The conductive material may be, for example, a metal such as copper, silver, gold, nickel, palladium, combinations thereof, alloys thereof, multi-layer stacks of the same or different metals, or any other suitable material.

[0022] Although a wire bond is illustrated in some embodiments, any suitable arrangement for electrically connecting the LED 112 to the lead frame 102 may be used. For example, metal bridge(s), solder, conductive epoxy, or other suitable connections may be used instead of a wire bond, in any of the packages 100 illustrated.

[0023] As described above, in Figures 1-3, the molding 120 forms a well 114 in which various components are disposed. In other embodiments, just enough of the material forming the molding 120 is used to structurally secure the relative positions of the lead frame parts 104 without forming the well 114. In other embodiments, the molding 120 forms the well 114 with shallow side walls 118, for example just deep enough to contain the LED 112, wire bond(s) 116 (if present) or other components within the well 114.

[0024] An encapsulant 122 is shown disposed within the well 114. In some embodiments, the encapsulant 122 comprises a transparent material that protects the LED 112 and other components within the well 114, such as the wire bond 116 if present. In some embodiments, the encapsulant 122 includes materials such as wavelength converting materials, materials that improve the thermal performance of the encapsulant 122, materials that cause or reduce light scattering, materials that act as filters, or any other suitable materials.

[0025] Though an LED 112 is described, in various embodiments, the LED 112 may be replaced with other types of light emitting devices such as laser diodes and semiconductor light emitting devices made from other materials systems such as other III-V materials, III-phosphide, III-arsenide, II-VI materials, ZnO, or Si-based materials may be used. Blue or UV emitting light emitting

devices are often combined with one or more wavelength converting materials to produce different colors of light, such that combined light from the light emitting device and the wavelength converting materials appears white or any other color necessary for a given application.

[0026] Figures 4-8 illustrate a method of forming the package 100(1) of Figure 1 and also, together, illustrate an exploded view of the package 100(1) of Figure 1. It should be understood that, for clarity, some components have been omitted from the views illustrated in Figures 4-8. For example, the metal layer 106 is not shown.

[0027] In Figure 4, the lead frame 102 is formed. The posts 108 of the lead frame 102, which are exposed after forming the molding 120, are at a higher elevation than other portions of the lead frame 102, which are covered by the molding 120 when the molding 120 is formed. The lead frame may be formed by, for example, shaping a sheet of metal by molding, folding, stamping, punching, etching, or any other suitable technique. After forming the lead frame 102, a metal layer 106 (not shown) may be formed, for example over the entire surface of lead frame 120, or only certain locations, such as on the portions of the lead frame that are exposed after forming the molding 120. The metal layer 106 may be formed by plating, sputtering, evaporation, or any other suitable technique.

[0028] In Figure 5, the molding 120 is formed on and around the lead frame 120. The molding 120 may be formed by, for example, molding, injection molding, transfer molding, or any other suitable technique. The molding 120 may be shaped to form sidewalls 118 that form a well 114 suitable for enclosing an encapsulant 122, which is formed in Figure 8, described below. After forming insulator 120, only portions of the lead frame 102 are exposed, such as the pillars 108. Other portions of the lead frame 120 are covered by the molding 120. A majority of the bottom surface ("basin") 124 of the well 114 is covered by the molding 120, rather than the pillars 108. After forming the molding 120, other processing steps may be taken to expose areas (such as the pillars 108) that are not to be covered by the molding 120 in the final device. Suitable processing steps include wet or dry bead blasting, chemical etching, electrolysis, or any other suitable technique to clean the surface of the pillars 108. After such cleaning, other metal layers, such as silver, gold, nickel, palladium, or other suitable materials, may be deposited on the pillars 108.

[0029] In Figure 6, LED 112 and any other components, such as an electrostatic discharge protection chip or any other suitable component, are attached to the pillars 108 of the lead frame that are exposed. LED 112 and other components may be attached by, for example, soldering or any other suitable technique.

[0030] In Figure 7, one or more wire bonds 116 are formed, if used. Other electrical connections in addition to or as an alternative to wire bonds 116 may be formed, to provide electrical connection between LED 112 and the pillars 108.

[0031] In Figure 7, an encapsulant 122 is disposed in the well 114, covering the LED 112. The encapsulant 122 may be formed by, for example, molding, dispensing, or any other suitable technique. In some embodiments, the encapsulant 122 is disposed in the well 114 in a liquid or gel form, then cured into a solid. The encapsulant 122 may include wavelength converting materials to convert the light emitted by the LED chip to light of other colors. The combination of the light from the LED chip and the light emitted from the wavelength converting materials forms the final color of the light of the LED device.

[0032] The devices illustrated in Figures 1-8, or any of the devices described above, may be used in any suitable application such as, for example, general lighting, backlighting for displays, or specialized lighting applications. In some embodiments, the devices described above may be incorporated into a mobile phone.

[0033] Having described the embodiments in detail, those skilled in the art will appreciate that, given the present disclosure, modifications may be made without departing from the spirit of the inventive concept described herein. In particular, different features and components of the different devices described herein may be used in any of the other devices, or features and components may be omitted from any of the devices. A characteristic of a structure described in the context of one embodiment, may be applicable to any embodiment. Therefore, it is not intended that the scope of the description be limited to the specific embodiments illustrated and described.

[0034] Although features and elements are described above in particular combinations, one of ordinary skill in the art will appreciate that each feature or element can be used alone or in any combination with the other features and elements. In addition, the methods described herein may be implemented in a computer program, software, or firmware incorporated in a computer-readable medium for execution by a computer or processor. Examples of computer-readable media include electronic signals (transmitted over wired or wireless connections) and computer-readable storage media. Examples of computer-readable storage media include, but are not limited to, a read only memory (ROM), a random access memory (RAM), a register, cache memory, semiconductor memory devices, magnetic media such as internal hard disks and removable disks, magneto-optical media, and optical media such as CD-ROM disks, and digital versatile disks (DVDs).

* * *

CLAIMS

What is claimed is:

1. A light emitting diode (LED) package, comprising:
 - a lead frame comprising a first lead frame part electrically isolated from a second lead frame part, the first lead frame part including a first pillar that is raised above a lower surface of the first lead frame part and the second lead frame part including a second pillar that is raised above a lower surface of the second lead frame part;
 - a molding covering the lower surfaces of the lead frame parts and exposing at least a portion of the first pillar and the second pillar, wherein the molding comprises a highly optically reflective and electrically insulating material;
 - an LED device disposed over only the second pillar;
 - a first contact formed on the LED device, the first contact being electrically coupled to the first pillar via a first wire bond; and
 - a second contact formed on the LED device, the second contact being electrically coupled to the second pillar via a second wire bond.
2. The LED package of claim 1, wherein:
 - the molding includes side-walls shaped to form a well.
3. The LED package of claim 2, further comprising:
 - an encapsulant disposed within the well, the encapsulant configured to physically protect the LED device.
4. The LED package of claim 1, wherein the second pillar has a width that is greater than the width of the LED device.
5. The LED package of claim 1, wherein the molding comprises a silicone material.
6. The LED package of claim 1, further comprising:
 - plated metal disposed over the lead frame, both under the molding and on exposed respective surfaces of the first pillar and the second pillar.
7. The LED package of claim 1, further comprising:
 - plated metal disposed over the first pillar and the second pillar, but not on the lead frame under the molding.
8. A method of forming a light emitting diode (LED) package, the method comprising:
 - forming a lead frame comprising a first lead frame part electrically isolated from a second lead frame part, the first lead frame part including a first pillar that is raised above a lower surface of the first lead frame part, and the second lead frame part including a second pillar that is raised above a lower surface of the second lead frame part;

forming a molding on and around the lead frame, the molding covering the lower surfaces of the lead frame parts and exposing at least a portion of the first pillar and the second pillar;
mounting an LED device on only the second pillar;

electrically coupling a first contact of the LED device to the first pillar via a first wire bond;
and

electrically coupling a second contact of the LED device to the second pillar via a second wire bond.

9. The method of claim 8, wherein forming the molding comprises:

forming the molding to include side-walls shaped to form a well

10. The method of claim 9, further comprising:

disposing an encapsulant within the well, the encapsulant configured to physically protect the LED device.

11. The method of claim 8, wherein the second pillar has a width that is greater than the width of the LED device.

12. The method of claim 8, wherein the molding comprises a silicone material.

13. The method of claim 8, further comprising:

plating metal over the lead frame, both under the molding and on exposed surfaces of the first pillar and the second pillar.

14. The method of claim 8, further comprising:

plating metal over the first pillar and the second pillar, but not on the lead frame under the molding.

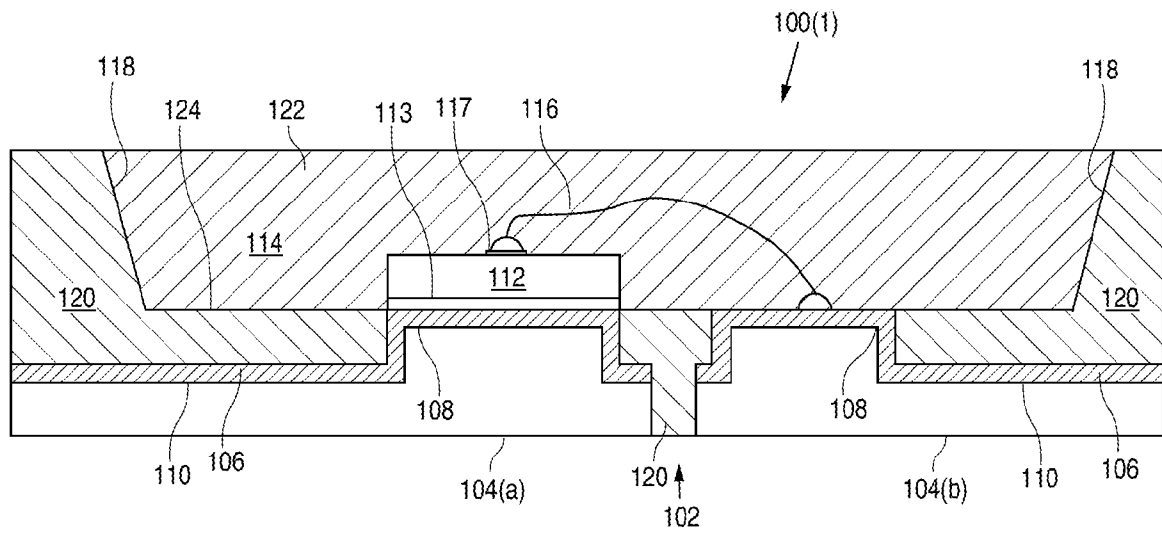

FIG. 1

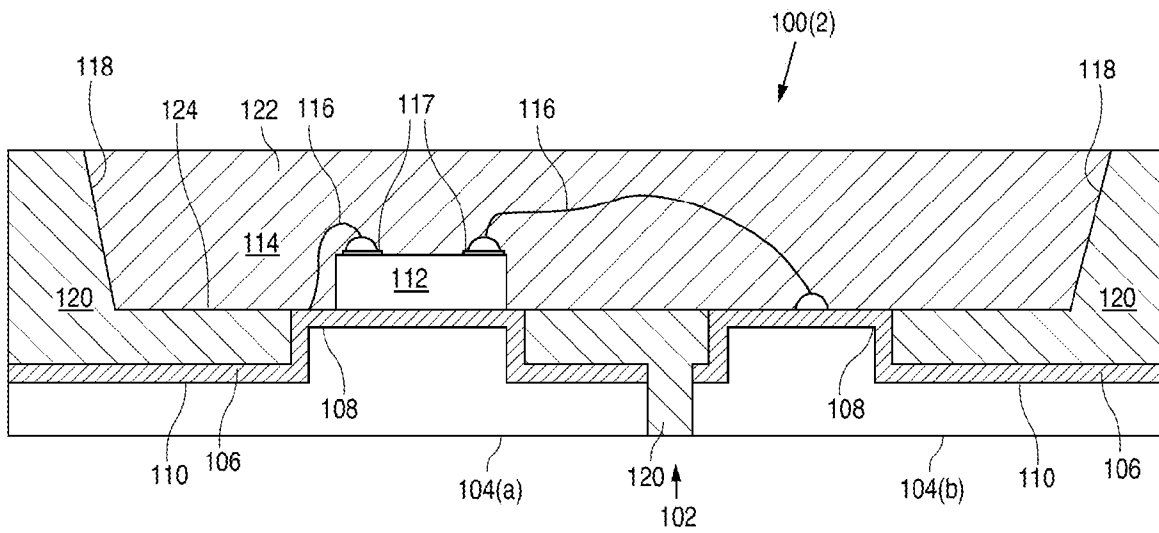

FIG. 2

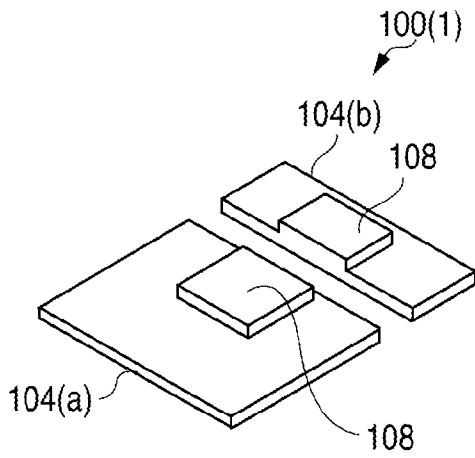

FIG. 4

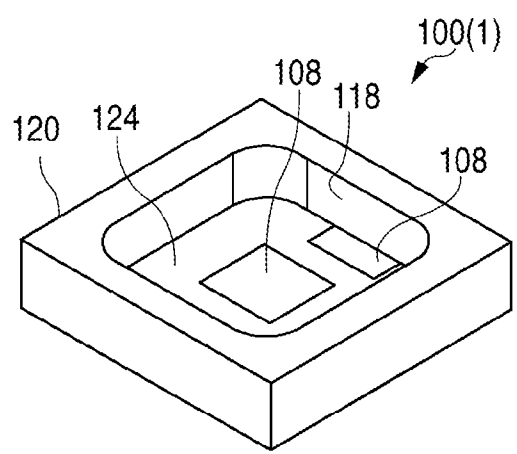

FIG. 5

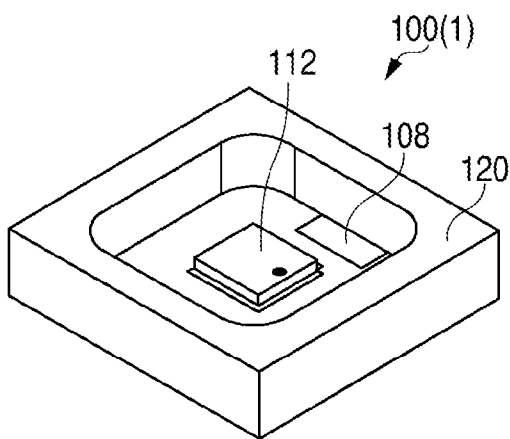

FIG. 6

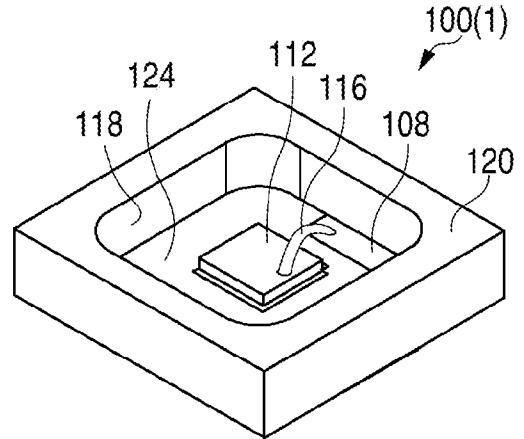

FIG. 7

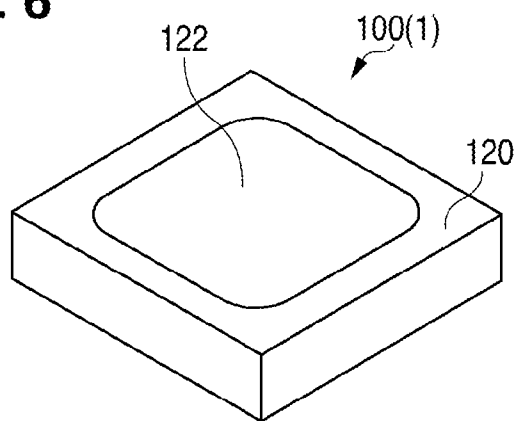

FIG. 8

INTERNATIONAL SEARCH REPORT

International application No
PCT/US2018/041774

A. CLASSIFICATION OF SUBJECT MATTER
 INV. H01L33/62 H01L33/48
 ADD. H01L33/60

According to International Patent Classification (IPC) or to both national classification and IPC

B. FIELDS SEARCHED

Minimum documentation searched (classification system followed by classification symbols)
 H01L

Documentation searched other than minimum documentation to the extent that such documents are included in the fields searched

Electronic data base consulted during the international search (name of data base and, where practicable, search terms used)
 EPO-Internal

C. DOCUMENTS CONSIDERED TO BE RELEVANT

Category*	Citation of document, with indication, where appropriate, of the relevant passages	Relevant to claim No.
X	US 2013/343067 A1 (OKADA SATOSHI [JP]) 26 December 2013 (2013-12-26) abstract paragraphs [0037], [0044], [0047], [0054], [0075], [0087], [0091], [0096], [0102], [0117] - [0123] figures 2,7,9 -----	1-14

Further documents are listed in the continuation of Box C.

See patent family annex.

* Special categories of cited documents :

- "A" document defining the general state of the art which is not considered to be of particular relevance
- "E" earlier application or patent but published on or after the international filing date
- "L" document which may throw doubts on priority claim(s) or which is cited to establish the publication date of another citation or other special reason (as specified)
- "O" document referring to an oral disclosure, use, exhibition or other means
- "P" document published prior to the international filing date but later than the priority date claimed

- "T" later document published after the international filing date or priority date and not in conflict with the application but cited to understand the principle or theory underlying the invention
- "X" document of particular relevance; the claimed invention cannot be considered novel or cannot be considered to involve an inventive step when the document is taken alone
- "Y" document of particular relevance; the claimed invention cannot be considered to involve an inventive step when the document is combined with one or more other such documents, such combination being obvious to a person skilled in the art
- "&" document member of the same patent family

Date of the actual completion of the international search

18 September 2018

Date of mailing of the international search report

26/09/2018

Name and mailing address of the ISA/

European Patent Office, P.B. 5818 Patentlaan 2
 NL - 2280 HV Rijswijk
 Tel. (+31-70) 340-2040,
 Fax: (+31-70) 340-3016

Authorized officer

Gijsbertsen, Hans

INTERNATIONAL SEARCH REPORT

Information on patent family members

International application No

PCT/US2018/041774

Patent document cited in search report	Publication date	Patent family member(s)	Publication date	
US 2013343067	A1	26-12-2013	CN 103392242 A	13-11-2013
			JP 5920333 B2	18-05-2016
			JP 6156542 B2	05-07-2017
			JP 2016154255 A	25-08-2016
			JP WO2012117974 A1	07-07-2014
			TW 201240133 A	01-10-2012
			US 2013343067 A1	26-12-2013
			WO 2012117974 A1	07-09-2012
