

(19) World Intellectual Property Organization
International Bureau



(43) International Publication Date
20 September 2007 (20.09.2007)

PCT

(10) International Publication Number
WO 2007/106012 A1

(51) International Patent Classification:
H01Q 1/24 (2006.01)

(21) International Application Number:
PCT/SE2007/000211

(22) International Filing Date: 5 March 2007 (05.03.2007)

(25) Filing Language: English

(26) Publication Language: English

(30) Priority Data:
0600548-2 13 March 2006 (13.03.2006) SE

(71) Applicant (for all designated States except US): LAIRD TECHNOLOGIES AB [SE/SE]; Box 500, S-184 25 Åkersberga (SE).

(72) Inventors; and

(75) Inventors/Applicants (for US only): SJÖBERG, Johan [SE/SE]; Rådjursstigen 12, S-170 76 Solna (SE). NILSSON, Jerry [SE/SE]; Mästarbacken 137, S-129 40 Hägersten (SE).

(74) Agents: ROMEDAHL, Bengt et al.; Kransell & Wennborg KB, Box 27834, S-115 93 Stockholm (SE).

(81) Designated States (unless otherwise indicated, for every kind of national protection available): AE, AG, AL, AM, AT, AU, AZ, BA, BB, BG, BR, BW, BY, BZ, CA, CH, CN, CO, CR, CU, CZ, DE, DK, DM, DZ, EC, EE, EG, ES, FI, GB, GD, GE, GH, GM, GT, HN, HR, HU, ID, IL, IN, IS, JP, KE, KG, KM, KN, KP, KR, KZ, LA, LC, LK, LR, LS, LT, LU, LY, MA, MD, MG, MK, MN, MW, MX, MY, MZ, NA, NG, NI, NO, NZ, OM, PG, PH, PL, PT, RO, RS, RU, SC, SD, SE, SG, SK, SL, SM, SV, SY, TJ, TM, TN, TR, TT, TZ, UA, UG, US, UZ, VC, VN, ZA, ZM, ZW.

(84) Designated States (unless otherwise indicated, for every kind of regional protection available): ARIPO (BW, GH, GM, KE, LS, MW, MZ, NA, SD, SL, SZ, TZ, UG, ZM, ZW), Eurasian (AM, AZ, BY, KG, KZ, MD, RU, TJ, TM), European (AT, BE, BG, CH, CY, CZ, DE, DK, EE, ES, FI, FR, GB, GR, HU, IE, IS, IT, LT, LU, LV, MC, MT, NL, PL, PT, RO, SE, SI, SK, TR), OAPI (BF, BJ, CF, CG, CI, CM, GA, GN, GQ, GW, ML, MR, NE, SN, TD, TG).

Published:
— with international search report

For two-letter codes and other abbreviations, refer to the "Guidance Notes on Codes and Abbreviations" appearing at the beginning of each regular issue of the PCT Gazette.

(54) Title: AN ANTENNA ARRANGEMENT AND A PORTABLE RADIO COMMUNICATION DEVICE FOR SUCH AN ANTENNA ARRANGEMENT

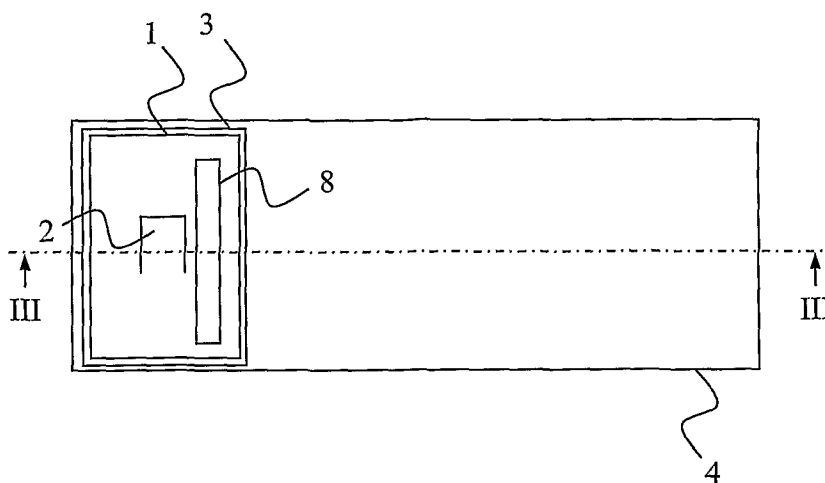

(57) Abstract: The present invention relates to an antenna arrangement comprising a flexible film (1) having a radiating element (8) mounted to a first side of a dielectric carrier (3). The dielectric carrier (3) has a through hole (5) from the first side thereof to a second side, opposite the first side, thereof. The flexible film (1) is dielectric and comprises a cut linear pattern providing a flip (2) positioned over said through hole (5), wherein said flip (2) is flush with said flexible film (1).

WO 2007/106012 A1

**AN ANTENNA ARRANGEMENT AND A PORTABLE RADIO COMMUNICATION
DEVICE FOR SUCH AN ANTENNA ARRANGEMENT**

FIELD OF THE INVENTION

The present invention generally relates to antenna
5 arrangements. In particular the present invention relates to
an antenna arrangement comprising a flexible film.

BACKGROUND OF THE INVENTION

Antennas for mobile or cellular phones, or other portable
radio communication devices, are today often mounted within
10 the chassis of the device it is used for. Since there today
is a demand for mobile phones that are small sized there is
a limited space for all desired components in a mobile
phone, which puts design restrictions on the components in
the mobile phone. Antennas are therefore sometimes mounted
15 above other components mounted on a printed wiring board in
the mobile phone.

When a component mounted under an antenna needs to be
accessed, e.g. for repair or for measurement tests, the
antenna needs to be dismantled. It is however not desirable
20 to dismantle an antenna, as the remounting of the antenna
needs to be very precise or else the antenna characteristics
may be changed in a negative way.

SUMMARY OF THE INVENTION

An object of the present invention is to provide an antenna
25 arrangement giving access to components mounted under the
antenna arrangement.

Another object of the present invention is to provide a
portable radio communication device giving access to

components mounted under an antenna arrangement of the portable radio communication device.

These objects, among others, are according to the present invention attained by an antenna arrangement and a portable
5 radio communication device, respectively, as defined in the appended claims.

By providing an antenna arrangement with a flexible film having a radiating element, which flexible film is dielectric and provided with a cut linear pattern over a
10 through hole in a dielectric carrier, it is possible to access a component mounted below the antenna arrangement by pushing a flip formed by the cut linear pattern into the through hole. The flip can thereafter, if desired, be mounted back over the through hole again reforming the
15 antenna arrangement to its original shape. In this way the appearance of the antenna arrangement is very little limited by an access door to the components under the antenna arrangement, at the same time allowing a reliable mounting of the radiating element onto the dielectric carrier. The
20 radiating element is many times very small and thin and handling of it is difficult. By embedding the radiating element into a dielectric film, called a flex film, to support the radiating element its handling and use is facilitated.

25 Further features and advantages of the present invention will be evident from the following description.

BRIEF DESCRIPTION OF THE DRAWINGS

The present invention will become more fully understood from the detailed description of embodiments given below and the
30 accompanying drawings, which are given by way of

illustration only, and thus, are not limitative to the present invention, wherein:

Fig. 1 shows a plan view of an antenna arrangement according to a first embodiment of the present invention;

5 Fig. 2 shows an exploded side view of the antenna arrangement shown in Fig. 1;

Fig. 3 shows an exploded side view of a cut along the line III-III in Fig. 1 with a flip closed;

10 Fig. 4 shows an exploded side view of a cut along the line III-III in Fig. 1 with a flip open;

Fig. 5 shows an antenna arrangement according to a second embodiment of the present invention; and

Figs. 6-9 show different cut patterns according to the present invention.

15 DETAILED DESCRIPTION OF EMBODIMENTS

In the following description, for purpose of explanation and not limitation, specific details are set forth, such as particular techniques and applications in order to provide a thorough understanding of the present invention. However, it
20 will be apparent for a person skilled in the art that the present invention may be practiced in other embodiments that depart from these specific details. In other instances, detailed description of well-known methods and apparatuses are omitted so as not to obscure the description of the
25 present invention with unnecessary details.

A first embodiment of the present invention will now be described with reference to Figs. 1-4.

An antenna arrangement comprises a flexible film 1 having a radiating element 8 mounted to a dielectric carrier 3. The flexible film 1 is dielectric and support handling and use of the radiating element 8, particularly handling prior and during mounting and use when mounted. The antenna arrangement is in turn mounted on a printed wiring board (PWB) 4 of a portable radio communication device such as a mobile phone or similar.

The PWB 4 has one or more components 6, or access points for e.g. measurement probes, mounted under the antenna arrangement and more precisely under the flexible film 1, i.e. the component 6 and the flexible film 1 occupy the same area of the PWB 4. The dielectric carrier 3 is provided with a through hole 5 substantially above the component 6. The flexible film 1 comprises a flip 2 positioned over the through hole 5, provided by a linear pattern, e.g. cut in a punch action, as it is not desirable to cut out material from the flexible film 1 since removal of such cutout parts are intricate and thus expensive. By a linear pattern the dimension of the cut is intended, whereby the pattern could be curved but still linear.

The flexible film 1, including the flip 2, is preferably attached to the dielectric carrier 3 by an adhesive, but could alternatively be attached by e.g. ultrasonic welding or heat staking. By providing the flexible film 1 with a non-curing adhesive the flip 2 is sturdily kept in position, flush with the flexible film 1, during mounting and use, despite the cut linear pattern, as the adhesive will bleed back over the cut linear pattern providing a supportive surface of the flexible film 1 substantially without any cut.

The through hole 5 is large enough to allow access through the antenna arrangement to the component 6 or access point on the PWB 4, either for removal/mounting of the component 6 or for passing through e.g. a measurement probe. By having the flip 2 somewhat smaller than the through hole 5 the flip 2 can be pushed into the through hole 5, e.g. by a measurement probe, whereby the flip 2 folds into the through hole 5 along a non-cut portion thereof. The flip 2 preferably has the same shape and is only slightly smaller than the outline of the through hole 5 to provide an as large as possible service door to the PWB 4 under the antenna arrangement. Preferably, the through hole 5 comprises a straight portion along which the flip 2 is folded into the through hole 5. By having the cut linear pattern extending slightly outside of the outline of the straight portion of the through hole 5 the flexible film 1 is unlikely to rip open when the flip is folded into the through hole 5 along the straight portion thereof.

The flip 2 and the through hole 5 are preferably rectangular-shaped, or U-shaped, to provide a large service door to the PWB 4 below the antenna arrangement. Preferably the flip 2 is positioned within the outline of the flexible film 1 and outside the outline of the radiating element 8, in order to affect the radiation characteristics of the antenna arrangement as little as possible. The flexible film 1 is preferably significantly larger than the radiating element 8 thereof, particularly when the radiating element 8 is small, since small radiating elements, and thus small flexible films, are intricate to handle e.g. during mounting. If the cut linear pattern is provided across the radiating element 8, or within the radiating element 8, the flip 2 is preferably reattached after its removal, to

influence the radiation characteristics of the antenna arrangement as little as possible.

The provided flip 2 can thus be opened by a slight push thereon, revealing the through hole 5 as a service door to
5 the component 6 or the access point under the antenna arrangement.

A second embodiment of the present invention will now be described with reference to Fig. 5. This second embodiment of the present invention is identical to the first
10 embodiment described above, apart from that the cut linear pattern, and thus the flip 2, is V-shaped and that the radiating element 8 has a different shape.

Further, the radiating element 8 and the flip 2 can have a shape e.g. as shown in Figs. 6-9. Figs. 6-9 also illustrate
15 differently curved end portions of the cut linear pattern to prevent the flip 2 from being ripped open when the flip 2 is folded into the through hole 5 along the straight portion thereof.

It will be obvious that the present invention may be varied
20 in a plurality of ways. Such variations are not to be regarded as departure from the scope of the present invention as defined by the appended claims. The flexible film has e.g. been illustrated as having a rectangular design, but the design of the flexible radiating element is
25 not essential for the present invention and can have any desired shape, generally influenced by the design of the portable radio communication device and of the design of the radiation element. The design of the radiating element has been illustrated with straight portions but can in fact have
30 any desired shape comprising slots, apertures, elongated portions, etc. Further, the shape of the flip can be adapted

to fit into a desired design of the flexible film and the radiating element taking the form of a multitude of shapes. Also, more than one flip can be provided for a through hole, more than one flip can be provided for more than one through
5 hole, and a combination of both and/or a plurality of flips. All such variations as would be obvious for a person skilled in the art are intended to be included within the scope of the present invention as defined by the appended claims.

CLAIMS

1. An antenna arrangement comprising a flexible film (1) having a radiating element (8) mounted to a first side of a dielectric carrier (3), **characterized in that**
- 5 - said dielectric carrier (3) has a through hole (5) from said first side to a second side opposite said first side, and
- said flexible film (1) is dielectric and comprises a cut linear pattern providing a flip (2) positioned over said
10 through hole (5), wherein said flip (2) is provided flush with said flexible film (1).
2. The antenna arrangement as claimed in claim 1, wherein said flexible film (1) is removably mounted to said dielectric carrier (3) by an adhesive.
- 15 3. The antenna arrangement as claimed in claim 2, wherein said adhesive is non-curing.
4. The antenna arrangement as claimed in any of claims 1-3, wherein said cut linear pattern is generally U-shaped.
5. The antenna arrangement as claimed in any of claims 1-4,
20 wherein said cut linear pattern is substantially inside an outline of said through hole (5).
6. The antenna arrangement as claimed in any of claims 1-5, wherein said cut linear pattern is within an outline of said flexible film 1.
- 25 7. The antenna arrangement as claimed in any of claims 1-6, wherein said cut linear pattern is outside an outline of said radiating element (8).

8. The antenna arrangement as claimed in any of claims 1-7, wherein the circumference of said through hole (5) has at least one straight portion.

5 9. The antenna arrangement as claimed in claim 8, wherein said flip (2) is provided to be folded into said through hole (5) along said straight portion.

10. The antenna arrangement as claimed in any of claims 1-9, wherein said flip (2) has a shape substantially similar to the outline of said through hole (5).

10 11. The antenna arrangement as claimed in any of claims 1-10, wherein said cut linear pattern comprises a curved end portion.

15 12. A portable radio communication device, **characterized in** that it comprises an antenna arrangement as claimed in any previous claim.

1/2

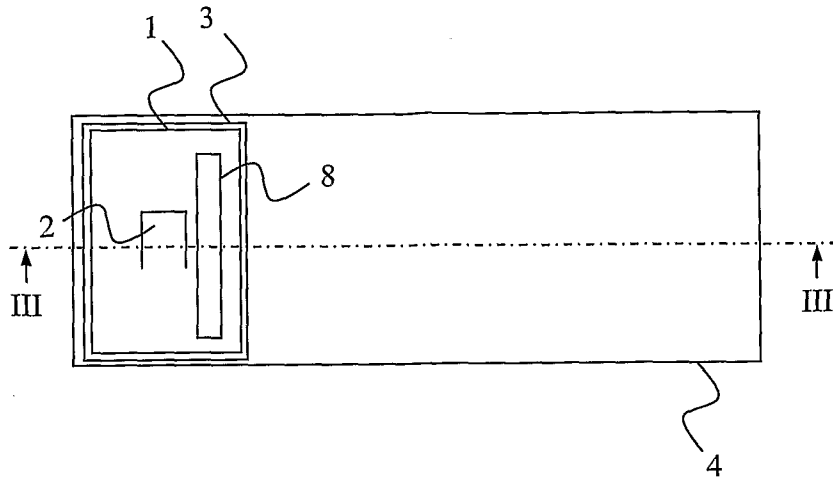

FIG. 1



FIG. 2

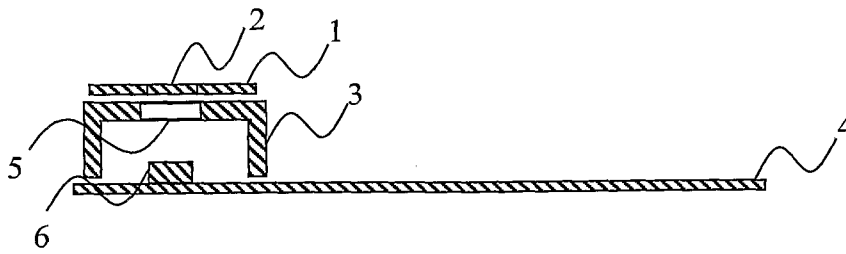

FIG. 3

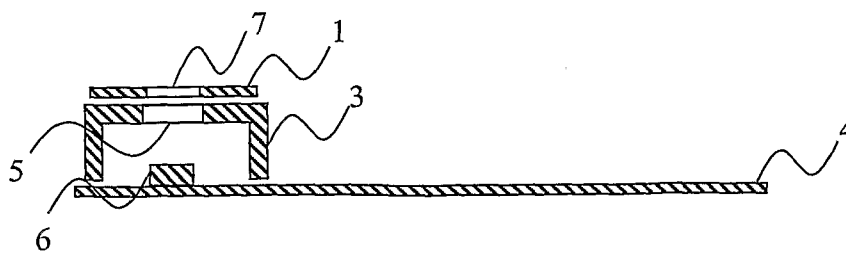

FIG. 4

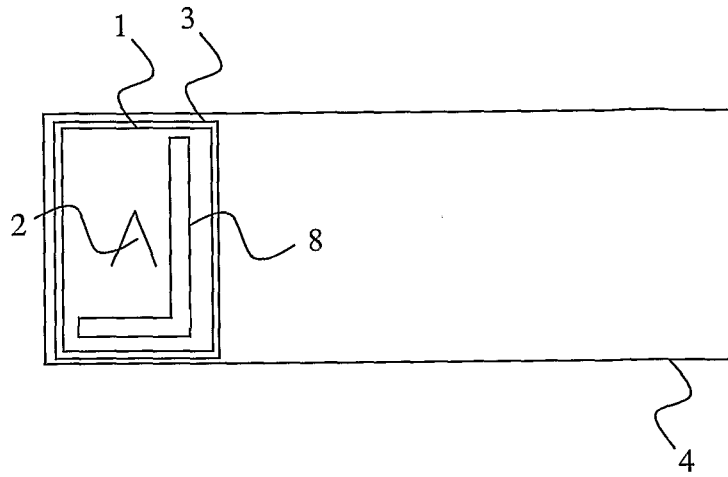

FIG. 5

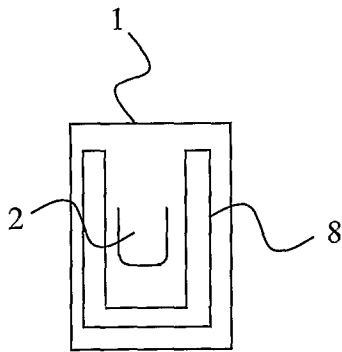

FIG. 6

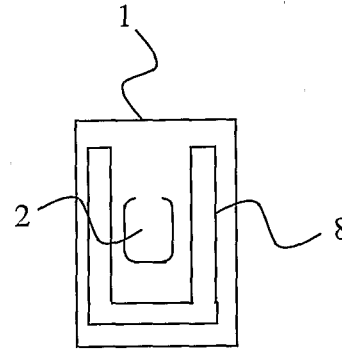

FIG. 7

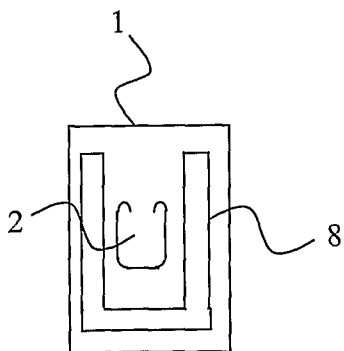

FIG. 8

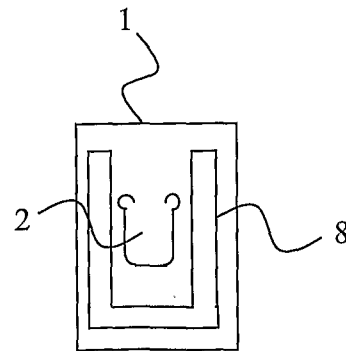

FIG. 9

INTERNATIONAL SEARCH REPORT

International application No.
PCT/SE2007/000211

A. CLASSIFICATION OF SUBJECT MATTER

IPC: see extra sheet

According to International Patent Classification (IPC) or to both national classification and IPC

B. FIELDS SEARCHED

Minimum documentation searched (classification system followed by classification symbols)

IPC: H01Q

Documentation searched other than minimum documentation to the extent that such documents are included in the fields searched

SE,DK,FI,NO classes as above

Electronic data base consulted during the international search (name of data base and, where practicable, search terms used)

EPO-INTERNAL, WPI DATA, PAJ

C. DOCUMENTS CONSIDERED TO BE RELEVANT

Category*	Citation of document, with indication, where appropriate, of the relevant passages	Relevant to claim No.
A	WO 0231912 A1 (AVANTEGO AB), 18 April 2002 (18.04.2002), the whole document --	1-12
A	US 20040075612 A1 (SPIROPOULOS, V.), 22 April 2004 (22.04.2004), the whole document --	1-12
A	WO 0133664 A1 (TELEFONAKTIEBOLAGET LM ERICSSON (PUBL)), 10 May 2001 (10.05.2001), the whole document --	1-12
A	EP 1445823 A1 (SONY ERICSSON MOBILE COMMUNICATIONS AB), 11 August 2004 (11.08.2004), the whole document --	1-12

 Further documents are listed in the continuation of Box C.
 See patent family annex.

* Special categories of cited documents:

"A" document defining the general state of the art which is not considered to be of particular relevance

"E" earlier application or patent but published on or after the international filing date

"L" document which may throw doubts on priority claim(s) or which is cited to establish the publication date of another citation or other special reason (as specified)

"O" document referring to an oral disclosure, use, exhibition or other means

"P" document published prior to the international filing date but later than the priority date claimed

"T" later document published after the international filing date or priority date and not in conflict with the application but cited to understand the principle or theory underlying the invention

"X" document of particular relevance: the claimed invention cannot be considered novel or cannot be considered to involve an inventive step when the document is taken alone

"Y" document of particular relevance: the claimed invention cannot be considered to involve an inventive step when the document is combined with one or more other such documents, such combination being obvious to a person skilled in the art

"&" document member of the same patent family

Date of the actual completion of the international search

25 May 2007

Date of mailing of the international search report

29 -05- 2007

Name and mailing address of the ISA/
Swedish Patent Office
Box 5055, S-102 42 STOCKHOLM
Facsimile No. +46 8 666 02 86

Authorized officer

Rune Bengtsson /OGU
Telephone No. +46 8 782 25 00

International patent classification (IPC)**H01Q 1/24 (2006.01)****Download your patent documents at www.prv.se**

The cited patent documents can be downloaded at www.prv.se by following the links:

- In English/Searches and advisory services/Cited documents (service in English) or
- e-tjänster/anförda dokument (service in Swedish).

Use the application number as username.

The password is **ZCEWKOZZJB**.

Paper copies can be ordered at a cost of 50 SEK per copy from PRV InterPat (telephone number 08-782 28 85).

Cited literature, if any, will be enclosed in paper form.

INTERNATIONAL SEARCH REPORT

Information on patent family members

31/03/2007

International application No.

PCT/SE2007/000211

WO	0231912	A1	18/04/2002	AU	9613101	A	22/04/2002
				SE	0003744	D	00/00/0000

US	20040075612	A1	22/04/2004	AU	6796601	A	30/01/2002
				CN	1284274	C	08/11/2006
				CN	1479956	A	03/03/2004
				EP	1311845	A	21/05/2003
				EP	1346439	A	24/09/2003
				JP	2004504509	T	12/02/2004
				SE	516861	C	12/03/2002
				SE	0002668	A	15/01/2002
				US	6803880	B	12/10/2004
				US	6935164	B	30/08/2005
				US	20040022128	A	05/02/2004
				WO	0206815	A	24/01/2002
				WO	02052678	A	04/07/2002

WO	0133664	A1	10/05/2001	AU	1426701	A	14/05/2001
				AU	1516901	A	14/05/2001
				CN	1237656	C	18/01/2006
				CN	1387687	A,T	25/12/2002
				EP	1226621	A	31/07/2002
				JP	2003513580	T	08/04/2003
				SE	523293	C	06/04/2004
				SE	9904002	A	04/05/2001
				US	7132987	B	07/11/2006
				WO	0133723	A	10/05/2001

EP	1445823	A1	11/08/2004	CN	1748337	A	15/03/2006
				US	20060038733	A	23/02/2006
				WO	2004070871	A	19/08/2004
