

(19) **DANMARK**

(10) **DK/EP 2819614 T3**



Patent- og
Varemærkestyrelsen

(12) **Oversættelse af
europæisk patentskrift**

-
- (51) Int.Cl.: **A 61 C 17/02 (2006.01)** **A 61 C 17/22 (2006.01)**
- (45) Oversættelsen bekendtgjort den: **2018-10-29**
- (80) Dato for Den Europæiske Patentmyndigheds bekendtgørelse om meddelelse af patentet: **2018-07-18**
- (86) Europæisk ansøgning nr.: **13712872.4**
- (86) Europæisk indleveringsdag: **2013-02-28**
- (87) Den europæiske ansøgnings publiceringsdag: **2015-01-07**
- (86) International ansøgning nr.: **FR2013050434**
- (87) Internationalt publikationsnr.: **WO2013128141**
- (30) Prioritet: **2012-03-01 FR 1251879**
- (84) Designerede stater: **AL AT BE BG CH CY CZ DE DK EE ES FI FR GB GR HR HU IE IS IT LI LT LU LV MC MK MT NL NO PL PT RO RS SE SI SK SM TR**
- (73) Patenthaver: **Willo 32, 12 rue Gemini, 87280 Limoges, Frankrig**
- (72) Opfinder: **DE GENTILE, Jean-Marie, 74 rue François Mourioux, 87220 Feytiat, Frankrig**
- (74) Fuldmægtig i Danmark: **Holme Patent A/S, Valbygårdsvej 33, 2500 Valby, Danmark**
- (54) Benævnelse: **Indretning til tandrensning**
- (56) Fremdragne publikationer:
DE-A1- 10 230 736
US-A- 3 731 675
US-A- 4 560 351
US-A1- 2011 027 746

CLEANING TEETH DEVICE

The present invention relates to a teeth cleaning device and method for simultaneously brushing all the teeth of at least one arch.

Its very simple use protocol is particularly intended for people with reduced mobility and, more generally, for all those having difficulties to clean their teeth with the traditional brushing systems.

Teeth cleaning is conventionally performed using a toothbrush. To be efficient, its handling requires learning and skill which are sometimes lacking.

The automation of the movements of the head of the electrical toothbrush facilitates its use but equally requires a good coordination and the compliance with a strict protocol. Cleaning is optimal only when it concerns a "standard" dental arch, namely without crooked teeth, and when the periodontal tissues are healthy. This ideal situation is rarely met with persons with disabilities.

It is then necessary to resort to systems adapted to complement and perfect the dental hygiene: the water toothpick, the floss and the interdental brush, the disinfecting mouthwashes. Their use is restricted to sufficiently skilled subjects and requires long minutes of patience.

There also exist particular situations, such as those of militaries on the move or in operation, for which ensuring the oral hygiene is difficult using a toothbrush.

The present inventor sought a solution overcoming all these disadvantages and, to this end, developed a teeth cleaning device according to which cleaning is performed by a contraction (which can also be referred to as being a constriction) and a relaxation, according to successive cycles, of a shell or mouth piece made of a resilient material

receiving and enclosing all the teeth of an arch or of both arches.

To the best knowledge of the applicant, no document of the prior art which describes a teeth cleaning or a dental treatment using a mouth piece or the like, such as US 2010/0151407 A1, EP 1506746, WO 2005/94719 A1, US 7537451 B1, DE 10153245, WO 2010/02498 A1, has suggested to perform a teeth cleaning by successive relaxation and contraction movements of a flexible mouth piece around the teeth of an arch or of two arches to be cleaned, said mouth piece being advantageously internally covered with a coating adapted to perfect the removal of soiling and of the dental plaque from the teeth and the interdental spaces, and the relaxation-contraction cycles being advantageously caused by the alternatively performed repeated operations of injecting in the mouth piece a fluid, namely a disinfecting new fluid, and then of evacuating from said mouth piece said used disinfecting fluid.

The US patent application US - A - 4 560 351 discloses a dental cleaning device according to the prior art, allowing to clean simultaneously the teeth of at least one arch.

The document DE 102 30 736 A1 discloses a dental cleaning device with a mouth piece shape combining the action of a fluid and of brushes.

Thus, in the case of using such a disinfecting fluid, the present invention provides the complementary advantage of allowing to perform as efficiently the cleaning and the disinfection of the teeth and of the interdental spaces, regardless of the configuration of the arches.

Furthermore, according to a particularly interesting embodiment, the use, for ensuring such relaxation-contraction cycles, of a device exerting pressure/depression cycles (pressure/depression cycle generator) within the mouth piece

allows to automate all the cleaning operations and requires no complex handling.

Thus, the invention allows to reduce the time dedicated to the oral hygiene and to the brushing to a few seconds and significantly increases its efficiency.

The present invention thus firstly relates to a teeth cleaning device for simultaneously cleaning the teeth of at least one arch, the device comprising a single or double arc-shaped mouth piece, adapted to enclose the teeth of an arch or of both arches at the same time, respectively, and to adapt, by its free edge or edges, on the corresponding gum or gums, said mouth piece being made of a flexible material accepting a reversible deformation and compatible with a medical use, and characterized by the fact that the device comprises fluid injection/extraction means for injecting fluid in the mouth piece and extracting said fluid from the inside of the mouth piece, said fluid injection/extraction means subjecting the mouth piece, once the latter is fitted on the teeth for their cleaning, to repeated fluid injection/extraction cycles causing pressurization/depressurization cycles of the mouth piece for cleaning the teeth by a combined action, in the mouth piece, of a fluid circulation on the teeth and between the teeth and a mechanical action of the internal surface of the mouth piece on the teeth, resulting from the relaxation and the constriction of the mouth piece during the injection and extraction cycles, respectively.

The overall shape of a simple mouth piece at rest is advantageously such that it can, for a given user, indifferently enclose the teeth of the upper maxilla or those of the lower maxilla (mandible). Indeed, the size correspondence of the upper and lower arches linked by the dental occlusion is such that, for the vast majority of people, a one and only mouth piece, given its elasticity, could adapt to both maxillae.

A simple mouth piece thus has the complementary shape of a recess of a dental arch to which it conforms by extending largely over the gum on both sides of the teeth.

On a front section passing through a median sector of the jaws, the contour of a simple mouth piece laterally begins at the bottom of the gingival-jugal sulcus and then bypasses the tooth leaving a gap corresponding to the thickness of an internal coating or to the height of the bristles internally covering the mouth piece when such a coating or bristles are provided such as described thereafter, and ends, in the case of the upper maxilla, in contact with the palatal mucosa and, in the case of the mandible, in the gingival-lingual mucous reflection area.

Indeed, the mouth piece can advantageously have, on at least one part of its internal surface, a non-smooth surface state or a non-smooth coating or interface, allowing it to promote the deconstruction of the dental plaque.

Thus, the mouth piece can have an internal surface, partially or entirely covered with reliefs, especially bristles in the manner of a brush. In particular, it can be provided that the internal surface of the mouth piece is covered with bristles on the whole surface facing the teeth.

The bristles can be of any kind and are intended, during the contraction/relaxation movements of the mouth piece, to deconstruct the dental plaque by friction and crushing.

Further technical solutions can be contemplated to obtain the same result of deconstruction of the dental plaque. It is thus possible to provide that a mouth piece has a slightly abrasive, porous, foam or sponge-type, flexible (which can be said to be depressible) interface having mechanical properties compatible with the teeth cleaning, the interface being interposed between the mouth piece and the teeth.

What has just been indicated for a simple mouth piece also applies for each mouth piece of a double mouth piece.

A mouth piece according to the invention is advantageously made in a flexible material which can be selected from flexible materials impermeable to gases (such as air) and liquids (water, cleaning liquid, disinfecting liquid), such as latex or silicone compatible with a medical use.

The technical advances made in the field of silicone for food use make this type of material the ideal constituent of the mouth piece.

The thickness of the mouth piece depends on the flexibility of the material used. It must maintain its shape without collapsing on itself. A final relative rigidity is required for facilitating its manipulation. The softer the consistency of the silicone will be, the thicker it must be.

The silicone nursing bottle nipples are an example of an ideal compromise between rigidity and flexibility, ensuring an optimal hold of the shape while preserving the resilient properties.

As in the case of a nursing bottle nipple, a non-homogeneous distribution of the resilient material, defining more or less thick areas, could serve as an armature.

Since the mouth piece is intended to undergo a depression for pressing it against the teeth as will be described thereafter, it should be advantageously provided on its entire free edge with a peripheral seal adapted to hold, under the best possible conditions, the air leaks resulting from the suction.

In other words, the mouth piece sealingly or substantially sealingly fits by its free edge or edges on the corresponding gum or gums.

By "substantially sealingly" is meant that a small amount of fluid (air, liquid, saliva) can be allowed to enter

the mouth piece positioned on the gum or gums provided that the repeated contraction/relaxation of the mouth piece can be correctly performed. However, it has been noted that, in operation, the cheeks and the lips, by abutting against the mouth piece, perfect the seal thereof on the gum or gums.

The peripheral adaptation of the mouth piece on the gum can be obtained by several technical solutions such as a "bellows" edge or a thicker edge made of a silicone with a lower hardness. Since the reason for this differential edge is to obtain the best possible pressing regardless of the anatomic configuration of the dental arches and their mucous environment, it must be designed sufficiently deformable and plastic for tightly conforming to the reliefs of the inside of the mouth. Moreover, since it has a lower hardness, it can avoid damaging the gums.

Thus, the free edge or edges of the mouth piece, simple or double respectively, can particularly be thickened in the shape of bulge. As indicated, this bulge can have a lower hardness than the rest of the mouth piece.

In the case of a device comprising a double mouth piece, said double mouth piece can be constituted by two simple mouth pieces attached by their bottom with or without communication opening(s) therebetween.

In other words, the mouth piece can be designed so as to simultaneously enclose both upper and lower dental arches. In this case, the two mouth pieces constituting this double mouth piece are secured to each other. This junction can be either a sealed junction, in which case both mouth pieces do not communicate with each other and there is no fluid exchange from one to the other, or a permeable junction, by the presence of the above-mentioned opening or openings, such that there is a transmission from one to the other of the fluids as well as of the pressure-depression cycles of a pressure-depression generator, as will be described in what follows.

In the first case, since each mouth piece composing the double mouth piece is independent from the other, the transmission of the pressures and the depressions will be via two independent pairs of transmission conduits, one of the conduits for injecting a fluid in the mouth piece and the other for extracting it.

In the second case, only one pair of transmission conduits will allow this injection and this extraction. These transmission conduits are described in more detail thereafter.

A mouth piece according to the invention can be manufactured by molding of a flexible material (such as silicone), with the reliefs (bristles) integrally molded with the mouth piece or integrated during the molding setting in the form of a fabric or a web having, for example, Nylon bristles.

In the case of a bulge provided on the edge of the mouth piece having a lower hardness than the rest of the mouth piece, this bulge could be formed by being separately injected in the mold or separately molded and then bonded to the rest of the mouth piece during the final setting, both portions being sticky at that time.

Furthermore, a mouth piece according to the invention can advantageously carry a gripping member for constituting a handle facilitating its insertion in the mouth.

Indeed, it is possible to add to a mouth piece according to the invention a handle-shaped gripping system so that it can be more easily inserted in the mouth and held, during its operation, pressed against the mucous membranes, thereby promoting the peripheral hermeticity. The mouth piece is then advantageously supported by a rigid structure extended in its anterior portion by a handle.

The mouth piece can also be inserted in a rigid receptacle adapted to be inserted in the mouth, wherein said

receptacle can comprise a gripping member for constituting a handle facilitating its insertion in the mouth.

The device according to the invention can also comprise a bite or occlusion plane located opposite the triturating portion of the antagonistic teeth for maintaining it in the mouth by closing the jaws, said bite or occlusion plane being carried by the mouth piece or by a gripping member carried by the mouth piece or by a rigid receptacle in which the mouth piece is inserted.

The subjects which are able to do it can, with such a bite or occlusion plane, maintain their mouth piece by tightening the jaws thereon.

According to a first embodiment of the present invention, the fluid injection/extraction means comprise at least one port made in said mouth piece for suctioning, by the wearer himself or herself, air and/or saliva it contains in order to contract the mouth piece, and then when the wearer stops suctioning, returning the air and/or saliva into said mouth piece for relaxing it.

The mouth piece can comprise at least one port for injecting/extracting fluid therein/therefrom.

In this case, the purging of the food residues is performed, similarly to a conventional brushing, by rinsing the mouth and the resilient mouth piece. This first embodiment corresponds to a particular use which, while remaining incidental, allows to improve the oral hygiene conditions of persons on the move such as military.

According to a second embodiment of the present invention, which is particularly preferred because it can impart to the device according to the invention its maximum efficiency with a short tooth brushing time, the fluid injection/extraction means inject in the mouth piece, in an injection phase, a dose of at least one fluid selected from air, an inert gas and a liquid, particularly a cleaning and/or

disinfecting liquid, and extract, in an extraction phase, said fluid dose from said mouth piece.

In particular, the fluid injection/extraction means can comprise a first fluid circuit connecting a new fluid reservoir to the inside of the mouth piece, a second fluid circuit connecting the inside of the mouth piece to a used fluid reservoir, pump means for circulating new fluid F_n in the first new fluid circuit to the mouth piece and for circulating used fluid in the second fluid circuit from the mouth piece to the used fluid reservoir, and valve means for isolating both fluid circuits from each other such that the flow of new fluid F_n is isolated from that of the used fluid F_u .

According to particular features:

- the first fluid circuit comprises, in order from the new fluid reservoir to the mouth piece, a first one-way valve, a branch to the chamber of a first plunger and a second one-way valve;

- the second fluid circuit comprises, in order from the mouth piece to the used fluid reservoir, a third one-way valve, a branch to the chamber of a second plunger and a fourth one-way valve;

- said first and second plungers have synchronous suction and discharge movements;

- the chambers of the first and second plungers are adapted to contain a same fluid dose;

- the second and fourth one-way valves are closed by a suction movement of the first and second plungers, respectively, and opened by a discharge movement of the first and second plungers, respectively;

- the first and third one-way valves are closed by a discharge movement of the first and second plungers, respectively, and opened by a suction movement of the first and second plungers, respectively;

whereby, during a suction movement of the first and second plungers, new fluid F_n is suctioned from the new fluid reservoir into the chamber of the first plunger, the used fluid F_u in the mouth piece being meanwhile passed into the chamber of the second plunger, the used fluid F_u of the mouth piece being prevented from penetrating the first fluid circuit by closing the second one-way valve and the used fluid F_u being prevented from circulating toward the used fluid reservoir by closing the fourth one-way valve and, during a discharge movement of the first and second plungers, new fluid is ejected from the chamber of the first plunger toward the mouth piece and used fluid F_u is ejected from the chamber of the second plunger toward the used fluid reservoir, the new fluid F_n being prevented from circulating in the second fluid circuit by closing the third one-way valve and the new fluid F_n being prevented from returning toward the new fluid reservoir by closing the first one-way valve, this arrangement allowing, during the fluid injection/extraction cycles, to avoid any mixing of the new fluid F_n and the used fluid F_u .

Means for controlling the plungers can be constituted by an electrical motor, the rotational movement of which is converted into a translation movement of said plungers by a mechanical device, wherein a rheostat for controlling the frequency of the pressurization and depressurization cycles of the mouth piece and/or a timer setting the operating time of the motor can be associated with said motor.

According to a particular alternative embodiment, the first fluid circuit further comprises, between the second one-way valve and the mouth piece, a first fitting, the second fluid circuit further comprises, between the mouth piece and the third one-way valve, a second fitting, said first and second fittings allowing to connect/disconnect the first and second fluid circuits to/from the mouth piece, the first and second fittings being further adapted to cooperate with

corresponding fittings of a pouch for inserting, the mouth piece being disconnected from the first and second fluid circuits, said pouch between the first and second fluid circuits for cleaning said first and second fluid circuits by purging.

Both fluid circuits can open into the mouth piece near each other, advantageously in the front central portion of said mouth piece.

The device of the present invention allows a method for simultaneously cleaning the teeth of at least one arch, by adapting on one or both of the dental arches the mouth piece, which is respectively simple or double, of a device as above-defined and by conducting repeated cycles for contracting the mouth piece on the teeth and relaxing this contraction are performed until the teeth and interdental spaces are cleaned by suctioning a fluid volume in said mouth piece and returning therein an equivalent fluid volume, respectively.

According to an optional particular feature of the method, 20 to 40 repeated contraction and relaxation cycles are performed during a period of time of 10 to 20 seconds.

Thus, according to a particularly preferred embodiment for cleaning teeth:

- in a first step, a cleaning liquid is injected via a plunger within the mouth piece made of a flexible and resilient material similar to a mouth protector, enclosing the dental arch. This has the effect of discreetly increasing the pressure within this resilient mouth piece and evenly distributing the fluid injected around the teeth and in the interdental spaces; and

- in a second step, this cleaning fluid is evacuated by suction, following a circuit separate from the injection circuit, and this short depression contracts the resilient mouth piece by pressing against the teeth the bristles internally covering it. The mechanical action of the bristles

on the teeth removes the dental plaque. The repetition of the injection and ejection cycles ensures the discharge of the plaque and the cleaning of the teeth.

To better illustrate the subject-matter of the present invention, several embodiments will be described thereafter, for indicative and non-limiting purposes, with reference to the appended drawings.

On the drawings:

- FIG.1 is a perspective view with a partial cutaway of a device for cleaning the teeth of an upper arch according to a first embodiment of the present invention;

- FIG.2 is a perspective view of a device for cleaning the teeth of an arch according to a second embodiment of the present invention;

- FIGS.3 and 4 are sectional schematic views of the mouth piece of FIG.1 fitted on the upper arch, at a premolar, in the respective relaxation and contraction positions;

- FIGS.5 and 6 are sectional schematic views of the mouth piece of FIG.1 fitted on the upper arch, at a central incisor, in the respective relaxation and contraction positions;

- FIGS.7 and 8 are sectional schematic views of a double mouth piece fitted on the upper and lower arches, at the premolars and central incisors, respectively, in the relaxation position;

- FIGS.9 and 10 are views similar to FIGS.7 and 8, respectively, of an alternative embodiment of the double mouth piece;

- FIGS.11 and 12 are diagrams illustrating the new fluid and used fluid paths toward and from the mouth piece of the device of FIG.1, respectively, causing the relaxation of said mouth piece with respect to its contact with the teeth,

and the contraction of said mouth piece, which surrounds the teeth, respectively; and

- FIG.13 is a schematic view of a pressure-depression generator ensuring a high frequency repetition of the relaxation-contraction cycles.

With reference to FIG.1, it can be seen that a simple shell or mouth piece 1 has been represented, closed at its ends, having the shape of an arc corresponding to a dental arch 2, the mouth piece 1 being shown fitted in place around this arch 2, that is, in the position in which it encloses the teeth 3 of this arch 2.

The mouth piece 1 has a generally U-shaped section having two side walls 4 joined at their opposed ends and connected to a bottom 5. Both side walls 4 become slightly closer to each other in the vicinity of their free edges, where they form a bulge 6 extending on the entire periphery of the mouth piece 1. The bulge 6 has a roughly cylindrical section.

In the illustrated example, the mouth piece 1 is made of silicone, from a mold allowing to obtain a silicone thickness of about 2 mm, with an average hardness number (Shore 30), conforming to the shape of a dental arch; the thicker bulge 6 corresponds to a cylinder with a diameter of about 4 mm and is made with a silicone with a lower hardness number (Shore 10).

As indicated, the narrowed walls of the mouth piece 1 along its free edge allow to exert on the mucous membrane a retention pressure.

The internal surface 7 of the mouth piece 1, that is, its internal surface in contact with the teeth 3, is covered with bristles 8, the base of which is integrated in the silicone wall. They are distributed as the bristles of a toothbrush would be, but are less long and more flexible.

Indeed, the space dedicated thereto being small (1 to 3 mm in the example shown), their length is selected for ensuring the cleaning of the gingival and dental tissues without damaging them. They are advantageously made of an end-rounded Nylon thread, again not to damage the gingival and dental tissues.

On the left and right parts of FIG.1 can be seen more precisely the position of the mouth piece 1 with respect to the arch at a cut passing through the second premolar 3a and at a cut passing through the right central incisor 3b, respectively.

The mouth piece 1, once in place on the arch 2, is adapted to receive a new fluid F_n for sweeping away the detritus removed from the teeth 3 during cleaning, the used fluid F_u must then be evacuated (see FIGS.11 and 12 which will be described in more detail thereafter).

The injection and the extraction of this cleaning fluid in and out of the mouth piece 1 is via two ports 5a, 5b made in the anterior portion thereof, just facing the free edge of the incisors. These two ports 5a, 5b constitute the areas for connecting two transmission conduits 9a, 9b, respectively, external to the mouth piece 1, having a length of a few centimeters, which end by a fitting (not shown) of a system for connecting two corresponding conduits 10a, 10b from the pressure-depression generator 11, as will be described thereafter with reference to FIG.13.

These transmission conduits 9a, 9b could be positioned indifferently at any points of this surface. However, for accessibility and comfort reasons, it is sensible to position them in the anterior part of the mouth piece 1, facing the central incisors, as shown in FIG.1.

In FIG.2, a mouth piece 1', similar to the mouth piece 1, is represented, but not covered with bristles, not comprising ports to which the transmission conduits 9a, 9b

connect with a pressure-depression generator 11, and comprising ports 5c made in its bottom 5.

The mouth piece 1' constitutes an independent and autonomous mouth piece which can ensure a cleaning of the teeth following the principle of contraction/relaxation on the teeth to be cleaned under the action of the movements of the mouth of the user himself or herself, the air and/or saliva passing through the ports 5c. This embodiment represents a particular case being useful in some circumstances as mentioned above.

FIGS.3 and 4 repeat, in more detail, the sections of the mouth piece 1 passing through the premolar 3a in the respective relaxation and contraction positions, the bristles 8 narrowing on the tooth in the contraction position. In the drawing, the mouth piece 1 has been represented with the ends of the bristles not pressing against the teeth in the relaxation position of FIG.3. In reality, the bristles 8 could already be pressed against the teeth in this position.

In FIGS.3 and 4, it can be noted that the peripheral bulge 6 has adapted to the gingival-jugal sulcus 12 as well as to the palate 13.

FIGS.5 and 6 are similar to FIGS.3 and 4, respectively, showing the mouth piece 1 at a central incisor 3b.

With reference to FIGS.7 and 8, in which the tongue 14, the upper lip 15 and the cheek 16 have been shown, it can be seen that views similar to FIGS.3 and 5, respectively, of a double mouth piece 100 adapted to enclose both the upper arch and the lower arch of a dentition are shown. The double mouth piece 100 is constituted by two mouth pieces similar to the mouth piece 1, the openings of which are oriented in opposite directions and which are attached by their bottoms 5.

As previously indicated, conduits such as the conduits 9a, 9b will be associated with each mouth piece of this double mouth piece 100.

With reference to FIGS.9 and 10, it can be seen that views similar to FIGS.7 and 8, respectively, are represented showing a double mouth piece 100' made according to an alternative embodiment of the mouth piece 100 of FIGS.7 and 8, alternative embodiment according to which the common bottom 5 has at least one port 17, the port or ports 17 being adapted to transmit the pressure differences from one mouth piece to the other of the double mouth piece 100'.

Thus, the double mouth piece 100' comprises a single conduit 9a and a single conduit 9b.

With reference to FIGS.11 and 12, it can be seen that the circulation of a new fluid F_n injected into a mouth piece 1 is schematically shown, for causing the relaxation of its wall, thereby disengaging it from the teeth, and that of a used fluid F_u , the extraction of which by depression out of the mouth piece 1 causes the contraction of the wall thereof against the teeth. By repeated and very fast relaxation-contraction cycles, a perfect cleaning of the teeth is obtained, with a very short time, as will be described thereafter.

To this end, plungers 18a, 18b move in a chamber 19a, 19b (FIG.13), respectively, for ejecting or suctioning volumes of the fluids F_n and F_u , respectively, which communicate with the conduits 10a, 10b (FIG.13), respectively, connected themselves to the conduits 9a, 9b (FIG.1), respectively.

On the path of each of the conduits 10a, 10b, is a branch 20a, 20b, respectively, the fluid F_n arriving in the conduit 10a by the branch 20a, and the used fluid F_u exiting the conduit 10b toward the branch 20b.

One-way valves 21a, 21b are arranged on the path of the conduits 10a, 10b, respectively, between the branches 20a,

20b, respectively, and the transmission conduits 9a, 9b, and one-way valves 22a, 22b are arranged on the path of the branches 20a, 20b, respectively. Small stop lines are schematically shown in FIGS.11 and 12 at the one-way valves 21a, 21b, 22a, 22b to better illustrate the two open and closed end positions they can take and, consequently, the circulation direction of the fluids.

In FIG.11, it can be seen that simultaneously pressing the plungers 18a, 18b along the arrows F creates a pressure P which closes the valves 21b and 22a, opens the valve 21a and sends in the mouth piece 1 the dose of new fluid F_n contained in the chamber of the plunger 18a, causing the relaxation of the mouth piece 1 with respect to its contact with the teeth, while the dose of used fluid F_u contained in the chamber of the plunger 18b is evacuated toward the outside of the system by the branch 20b, the valve 21b closing and the valve 22b opening under the pressure of the fluid F_u .

In FIG.12, it can be seen that simultaneously withdrawing the plungers 18a, 18b along the arrows f creates a depression D which opens the valve 22a, closes the valve 21a, so as to introduce a dose of fluid F_n in the chamber of the plunger 18a - which dose will be ready to be ejected in the mouth piece 1 when the stroke of the plunger 18a reverses, and to introduce the dose of fluid F_u from the mouth piece 1 to the chamber of the plunger 18b, by opening the valve 21b and closing the valve 22b due to the depression D from the removal of the plunger 18b, the dose of fluid F_u thus collected in the chamber in the plunger 18b being ready to be ejected toward the outside by the branch 20b when the stroke of the plunger 18b reverses.

In FIG.11, during the discharges of the plungers 18a, 18b, the valve 21b is closed by abutting by the pressure P on the plunger 18b side. The mouth piece 1 is inflated by the pressure P from the conduit 10a, which causes a fluid

circulation in the conduit 10b with a reduced pressure p ; the pressure difference on either side of the valve 21b maintains it closed.

In FIG.12, during the suction of the plungers 18a, 18b, the valve 21a is closed by abutment caused by the depression D on the plunger 18a side. The mouth piece 1 is compressed by the depression D from the conduit 10b, which causes a fluid circulation in the conduit 10a with a reduced depression d ; the pressure difference on either side of the valve 21a maintains it closed.

In FIG.13 has been schematically shown a pressure-depression generator 11, operating according to the principle which has just been described, with reference to FIGS.11 and 12. In this FIG.13, it is shown in the position where the plungers 18a, 18b have completely discharged the doses of fluid F_n and F_u , respectively, that they had previously suctioned.

The same reference numerals have been taken from FIGS.11 and 12 for designating similar parts.

In a housing 23 are mounted the plungers 18a, 18b adapted to slide in their chambers 19a, 19b. The fluid volumes moved by the plungers 18a, 18b pass in respective tubular parts 24a, 24b, constituted extensions of walls defining the chambers 19a, 19b which are sealingly connected to the base of the conduits 10a, 10b.

In the housing 23 is also mounted an electrical motor 25 adapted to drive a toothed wheel 26 which cooperates with a conventional mechanical device 27 converting the rotational movement into a repetitive translational movement for driving back and forth the plungers 18a, 18b. To this end, the device 27 is connected to the base of both plungers 18a, 18b and the electrical motor 25, powered by connecting wires 28 connected to batteries 29, transmits to both plungers 18a, 18b a back

and forth reciprocating movement allowing repetitive cycles of pressing and then withdrawal.

The electronic system for controlling the motor 25 has also been designated by the reference numeral 29, the housing referred by the reference numeral 29 comprising the batteries and the electronic system for controlling the motor 25. The control switches of the motor control electronic system are designated by the reference numeral 30.

The housing 23 also contains the injection tube of the fluid F_n (branch 20a), mounted on the conduit 10a (therefore made in two parts) by a T-fitting 31a, and the ejection tube of the fluid F_u (branch 20b) mounted on the conduit 10b (therefore made in two parts) by a T-fitting 31b.

The housing 23 also contains the four one-way valves 21a, 22a, 21b, 22b.

The sealed housing 23 envelops and secures the whole above-described device 11 and lets only the four conduits 10a, 10b, 20a, 20b protrude outside.

The conduits 10a, 10b for the mouth piece 1 are gathered into a common sheath 32. Their length, for manipulation comfort reasons, is about 1 meter. They are ended by a fitting of a connecting device intended to sealingly snap in the corresponding fitting located at the end of the conduits 9a, 9b at the front of the mouth piece 1 and allowing to connect the conduits 9a, 10a and the conduits 9b, 10b during brushing of the teeth.

Indeed, this connecting system must allow without damage, without alteration, in an easy manner and repeatedly, its connection and disconnection to/from the conduits 10a, 10b connecting the mouth piece 1 to the pressure-depression generator 11 for sealingly ensuring the injection and the evacuation of the cleaning liquids.

To do so, it is possible to resort to any appropriate technical solution provided that it ensures a correct

transmission of the flows ensuring alternatively the relaxation and contraction of the mouth piece; however, a "snap"-type device, such as mentioned above, remains the easiest device to implement.

The other two conduits 20a, 20b, designed to convey the fluid F_n from its storage container and to convey the fluid F_u to its evacuation container, respectively, stay independent and receive a sufficiently clear marking for avoiding any manipulation error. They are shorter than the previous ones.

One of the faces of the housing 23 comprises an impermeable control keypad allowing to turn on and off the electrical motor 25. This set of switches 30 can also control, via a rheostat, the frequency of the suction-ejection cycles and possibly set the operating time of the motor 25 using a timer.

On another one of its faces, the housing 23 comprises a trapdoor giving access to the housing of the batteries 29 allowing to replace them when they are used. The closing system of this trapdoor makes it completely waterproof.

The connecting system between the mouth piece 1 and the pressure-depression generator 11 must ensure a perfect cleanliness to all users of a personal mouth piece which would use a same generator 11. As only one generator 11 allows the operation of several mouth pieces 1, the problems generated by potential cross-contaminations must be subjected to a particular attention.

To this end, the area of the end of the double conduit 10a, 10b sheathed in 32 from the generator 11 can advantageously be provided, just before its connecting system to the ends of the conduits 9a, 9b of the mouth piece 1, with a second pair of one-way valves, adapted to open and close in the same direction as the one-way valves 21a, 21b.

For the same reason, the conduits 9a, 9b have a minimum length so as to avoid any potentially contaminated

liquid backflow from the mouth piece 1 into the inside of the conduit 10a allowing to inject the cleaning fluid.

Finally, at the end of a session of use, the pressure-depression generator 11 and the array of conduits 10a, 10b, 20a, 20b must be drained using a piece allowing to connect the injection conduit 10a and the suction conduit 10b.

Thus, a piece for draining the conduit array is provided to be connected to the system instead of the mouth piece 1 at the end of use thereof. This piece is constituted by a fitting corresponding to that of the end of the conduits 10a, 10b and comprises a sealed chamber or pouch made of a resilient material, for example of a volume from 1 to 2 cm³, designed to be inflated and contracted according to the circulation of the fluids. It is inserted instead of the mouth piece 1, once the use thereof is over, and allows to close the circuit for a final drainage of the device.

It is designed to stay in place for closing the circuit and allowing to store the cleaning device. In this particular embodiment, this piece is attached to the housing 23 of the generator 11.

The fittings of the system advantageously comprise a foolproof device for avoiding an inversion of the conduits.

With the mouth piece 1 and its pressure-depression generator 11, the user wishing to perform a teeth cleaning will firstly ensure that the ends of the conduits 20a, 20b for drawing and evacuating the cleaning liquid are indeed immersed in their respective containers.

The user will then insert the fittings of the conduits 9a, 9b of its mouth piece 1 to the corresponding fittings of the conduits 10a, 10b of the generator 11, respecting the direction set by the shape of the male and female parts of the fittings. Their shape is advantageously such that it allows their cooperation (co-adaptation) in only one position. A click from a flexible plastic tab inserting in

its housing at the end of the stroke indicates that locking is complete. It will be noted that, during deinsertion, a simple pressure on the basis of this tab will unlock the system.

After having moistened the mouth piece 1 by passing it under water, the user will insert it in his or her mouth, on one of both arches.

He or she will then control the switching on of the electrical motor 25 of the generator 11 by pushing on the trigger switch 30 located on the housing 23.

From triggering until stopping of the motor, the following operating cycles will reproduce about 2 per second:

- suction of the new cleaning liquid from the container toward the chamber of the first plunger 18a and, simultaneously, depression exerted in the mouth piece 1 resulting in a contraction (constriction) of the bristles 8 around the teeth and the ejection of the fluids contained in the thus-narrowed space. Suction of these fluids into the chamber of the second plunger 18b,

- injection of the new cleaning liquid from the chamber of the first plunger 18a toward the mouth piece 1 and, simultaneously, return to the normal shape thereof resulting in a distribution of this liquid around the teeth in the space thereby released. Evacuation of the fluids contained in the chamber of the second plunger 18b toward the destination container.

The estimated number of cycles for a complete cleaning is about 30, that is, approximately 15 seconds of operation.

Once the first dental arch is cleaned, the user will insert the mouth piece on the antagonist arch for 30 new cycles.

After having removed its mouth piece, he or she can disconnect it from the pressure-depression generator 11 and briefly rinse it under water. Then, he or she will drain the

circuits of the device by connecting the connecting piece instead of the mouth piece 1 and by performing several cycles unloaded. This connecting piece will remain connected until the next use of the teeth cleaning device. For practical reasons, this piece is, as already indicated, in this particular embodiment of the invention, attached to the housing of the pressure-depression generator 11 and facilitates its storage.

The mouth piece according to the invention is an independent, removable device. It is personal and individual the same as a toothbrush would be. A group of individuals can use only one pressure-depression generator and each one can connect thereto its personal mouth piece.

The mouth pieces have a limited shelf life and must be regularly replaced. Everyone can select, from a range of different sizes, the mouth piece best suited to the shape of his or her dentition. A single-use device allowing to register the shape of the dental arch will facilitate this selection.

It is of course understood that the embodiments which have been described are for indicative and non-limiting purposes, and that modifications can be made thereto, the scope of the present invention being defined by the claims.

Krav

1. Tandrensningsindretning til samtidig rensning af tænderne i mindst en række, indretningen omfatter en enkel- eller dobbeltskinne (1; 1'; 100; 100') med bueform, der er indrettet til på samme tid at omslutte tænderne i henholdsvis en række eller begge rækker, og til ved sin/sine frie kant eller kanter at tilpasse sig på den/de tilsvarende gumme eller gummer, nævnte skinne (1; 1'; 100; 100') er fremstillet af et fleksibelt materiale, der tillader reversibel deformation og er kompatibelt med medicinsk brug, og er **kendetegnet** ved det faktum, at indretningen omfatter fluidinjektions-/ekstraktionsmidler til at injicere fluid i skinnen og ekstrahere nævnte fluid fra skinnens inderside, nævnte fluidinjektions-/ekstraktionsmidler udsætter skinnen, når sidstnævnte er anbragt på tænderne for at rense dem, for gentagne fluidinjektions-/ekstraktionscyklusser, der forårsager tryk-/trykaflastningscyklusser i skinnen for i skinnen at rense tænderne ved kombineret virkning af en fluidcirkulation på tænderne og mellem tænderne og en mekanisk virkning på tænderne fra skinnens indre overflade (7), der skyldes henholdsvis skinnens relaksation og sammentrækning under henholdsvis injektions- og ekstraktionscyklusserne.
2. Indretning ifølge krav 1, **kendetegnet** ved det faktum, at skinnen (1; 100; 100') på mindst en del af sin indre overflade (7) har en ikke-glat overflade, eller en ikke-glat belægning eller grænseflade, der tillader det at fremme destrukturering af tandplakken.
3. Indretning ifølge krav 2, **kendetegnet** ved det faktum, at skinnen (1; 100; 100') har en indre overflade (8), delvist eller helt dækket med relieffer, især hår (8) som på en tandbørste, eller har en grænseflade, der er fleksibel, porøs, af typen skum- eller svampe, svagt slibende, har mekaniske egenskaber, der er kompatible med tandrensningen, grænsefladen er indskudt mellem skinnen og tænderne.
4. Indretning ifølge et af kravene 1 til 3, **kendetegnet** ved det faktum, at skinnens (1; 1'; 100; 100') fleksible materiale er valgt blandt fleksible materialer, der er uigennemtrængelige for gasser og væsker, såsom latex eller silikone, der er kompatibel med en medicinsk brug.

5. Indretning ifølge et af kravene 1 til 4, **kendetegnet** ved det faktum, at den frie kant eller de frie kanter på helholdsvis den enkelte eller den dobbelte skinne (1; 1'; 100; 100') er gjort tyk med formen som en vulst (6).
6. Indretning ifølge et af kravene 1 til 5, omfattende en dobbeltskinne, **kendetegnet** ved det faktum, at nævnte dobbeltskinne (100; 100') består af to enkeltskinner fastgjorte ved deres bund med eller uden kommunikationsåbning(er) (17) derimellem.
7. Indretning ifølge et af kravene 1 til 6, **kendetegnet** ved det faktum, at skinnen bærer et gribeelement, der udgør et greb til at lette dens indføring i munden.
8. Indretning ifølge et af kravene 1 til 7, **kendetegnet** ved det faktum, at skinnen er indføjjet i en stiv holder, der indrettet til at blive ført ind i munden, nævnte holder kan omfatte et gribeelement til at udgøre et greb til at lette dens indføring i munden.
9. Indretning ifølge et af kravene 1 til 8, **kendetegnet** ved det faktum, at den omfatter et bide- eller lukkeplan placeret overfor de modstående tænders triturationsdel for at fastholde den i munden ved at lukke kæberne, nævnte bide- eller lukkeplan bæres af skinnen, eller af et gribeelement båret af skinnen, eller af en stiv holder, hvori skinnen er indføjjet.
10. Indretning ifølge et af kravene 1 til 9, **kendetegnet** ved det faktum, at skinnen omfatter mindst en åbning (5a) til injektion/ekstraktion af fluid deri/derfra.
11. Indretning ifølge krav 9, **kendetegnet** ved det faktum, at fluidinjektions-/ekstraktionsmidlerne omfatter et første fluidkredsløb til at forbinde et reservoir med nyt fluid til skinnens (1; 1'; 100; 100') indre, et anden fluidkredsløb til at forbinde skinnens (1; 1'; 100; 100') indre til et reservoir til brugt fluid, pumpemidler til at cirkulere nyt fluid (F_n) i det første kredsløb til nyt fluid til skinnen (1; 1'; 100; 100'), og til at cirkulere brugt fluid i det anden fluidkredsløb fra skinnen (1; 1'; 100; 100') til reservoiret til brugt fluid, og ventilmidler til at isolere de to fluidkredsløb fra hinanden, således at cirkulationen af nyt fluid (F_n) er isoleret fra cirkulationen af det brugte fluid (F_u), fluidinjektions-/ekstraktionsmidlerne injicerer en dosis af mindst ét fluid valgt blandt luft, en inert gas og en væske i skinnen (1; 1'; 100; 100') i en injektionsfase, især en rensnings- og/eller

desinfektionsvæske, og ekstraherer nævnte fluiddosis fra nævnte skinn (1; 1'; 100; 100') i en ekstraktionsfase.

12. Indretning ifølge krav 11, **kendetegnet** ved det faktum, at:

- det første fluidkredsløb omfatter, i rækkefølge fra reservoiret til nyt fluid til skinnen (1; 1'; 100; 100'), en første kontraventil (22a), en forgrening til et første stempels (18a) kammer og en anden kontraventil (21a);
- det anden fluidkredsløb omfatter, i rækkefølge fra skinnen (1; 1'; 100; 100') til reservoiret til brugt fluid, en tredje kontraventil (21b), en forgrening til et anden stempels (18b) kammer og en fjerde kontraventil (22b);
- nævnte første og nævnte anden stempel (18a og 18b) har synkrone ansugnings- og fordrivningsbevægelser;
- det første og det anden stempels (18a og 18b) kamre er indrettede til at indeholde en samme fluiddosis;
- den anden (21a) og fjerde (22b) kontraventil lukkes af en ansugningsbevægelse (f) af henholdsvis det første (18a) og det anden (18b) stempel, og åbnes af en fordrivningsbevægelse (F) af henholdsvis det første (18a) og det anden (18b) stempel;
- den første (22a) og den tredje (21b) kontraventil lukkes af en fordrivningsbevægelse (F) af henholdsvis det første (18a) og det andet (18b) stempel, og åbnes af en ansugningsbevægelse (f) af henholdsvis det første (18a) og det andet (18b) stempel; hvorved nyt fluid (Fn), under en ansugningsbevægelse (f) af det første (18a) og det anden (18b) stempel, suges fra reservoiret til nyt fluid ind i det første stempels (18a) kammer, det brugte fluid (Fu) i skinnen (1; 1'; 100; 100') er samtidig blevet bragt til at passere ind i det anden stempels (18b) kammer, skinnens (1; 1'; 100; 100') brugte fluid (Fu) forhindres i at trænge ind det første fluidkredsløb ved at lukke den anden kontraventil (21a), og det brugte fluid (Fu) forhindres i at cirkulere mod reservoiret til brugt fluid ved at lukke den fjerde kontraventil (22b), og under en fordrivningsbevægelse af det første (18a) og det andet (18b) stempel udstødes nyt fluid fra det første stempels (18a) kammer til skinnen (1; 1'; 100; 100') og brugt fluid (Fu) udstødes fra det andet stempels (18b) kammer mod reservoiret til brugt fluid, det nye fluid (Fn) forhindres i at cirkulere i det andet fluidkredsløb ved at lukke den tredje kontraventil (21b), og det nye fluid (Fn) forhindres i at returnere til reservoiret med det nye fluid ved at lukke den første

kontraventil (22a), hvilket arrangement tillader at undgå enhver blanding af det nye fluid (Fn) og det brugte fluid (Fu) i fluidinjektions-/ekstraktionscykluserne.

13. Indretning ifølge krav 12, **kendetegnet** ved det faktum, at midler til at styre stemplerne udgøres af en elektrisk motor (25), hvis rotationsbevægelse omdannes til en translationsbevægelse af nævnte stempler (18a og 18b) ved hjælp af en mekanisk indretning (27), en reostat til at styre frekvensen af skinnens tryk- og trykaflastningscykluser og/eller en timer til at indstille motorens driftstid, kan være associeret med motoren.
14. Indretning ifølge et af kravene 11 til 13, **kendetegnet** ved det faktum, at det første fluidkredsløb yderligere omfatter et første forbindelsesstykke mellem den anden kontraventil (21a) og skinnen (1; 1'; 100; 100'), at det anden fluidkredsløb yderligere omfatter et anden første forbindelsesstykke mellem skinnen (1; 1'; 100; 100') og den tredje kontraventil (21b), nævnte første og anden forbindelsesstykke gør det muligt at tilkoble/frakoble det første og det andet fluidkredsløb til/fra skinnen (1; 1'; 100; 100'), det første og andet første forbindelsesstykke er yderligere indrettede til at samvirke med tilsvarende første forbindelsesstykke på en pose til, når skinnen (1; 1'; 100; 100') frakobles det første og det andet fluidkredsløb, at indføre nævnte pose mellem det første og det anden fluidkredsløb for at rense det første og det anden fluidkredsløb ved hjælp af tømning.
15. Indretning ifølge et af kravene 12 til 14, **kendetegnet** ved det faktum, at de to fluidkredsløb udmunder i skinnen (1) nær hinanden, fordelagtigt i nævnte skinnes (1) forreste midterdel.
16. Indretning ifølge krav 9, **kendetegnet** ved det faktum, at fluidinjektions-/ekstraktionsmidlerne består af mindst en åbning (5a) dannet i nævnte skinne (1'), hvilken tillader brugeren selv at ansuge luft og/eller spyt, som den indeholder, med henblik på at den trækker sig sammen, og derefter, når brugeren stopper med at ansuge, at returnere luften og/eller spyttet ind i nævnte skinne (1') for at relaksere den.

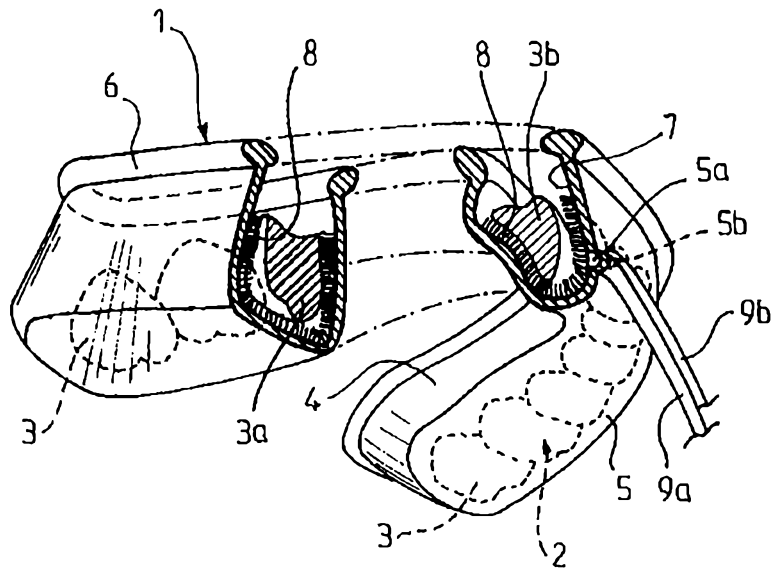

FIG. 1

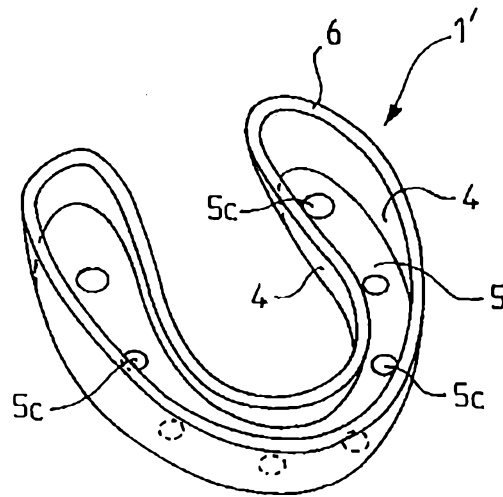

FIG. 2

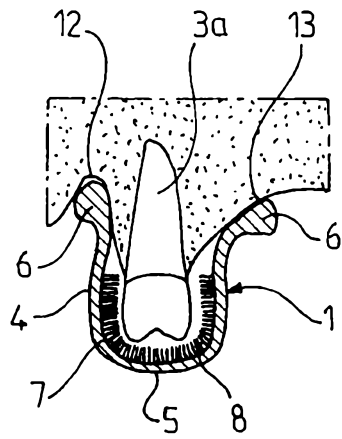

FIG. 3

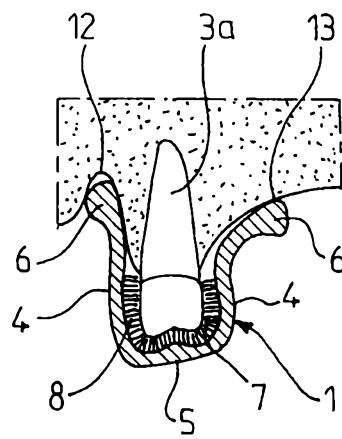

FIG. 4

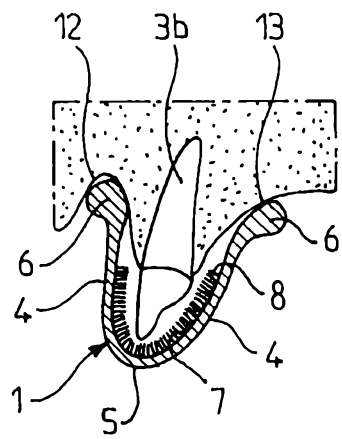

FIG. 5

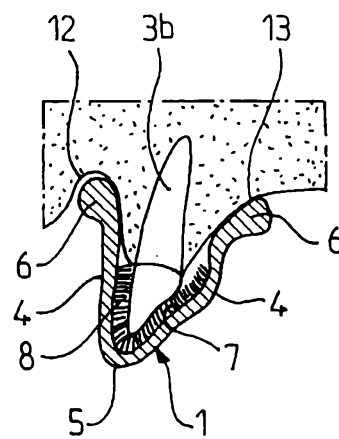

FIG. 6

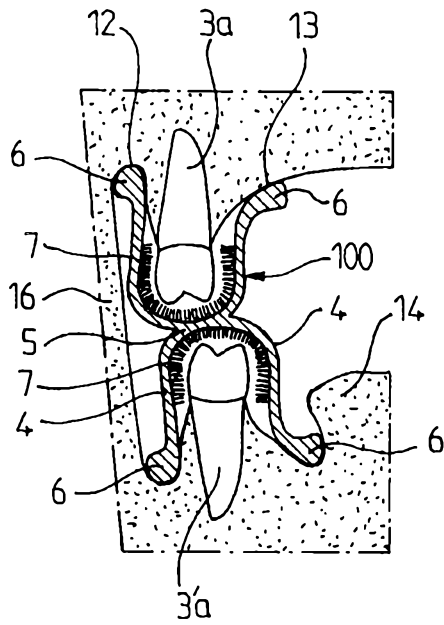

FIG. 7

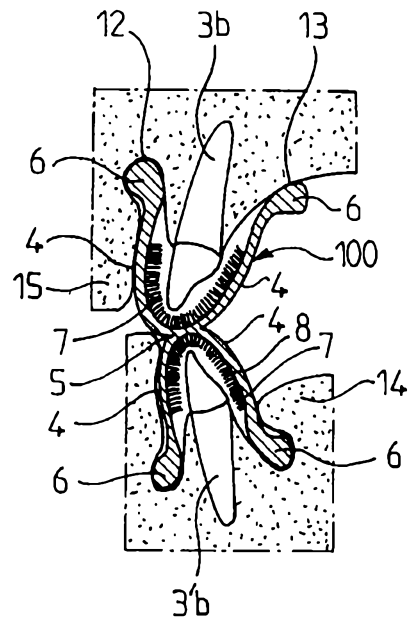

FIG. 8

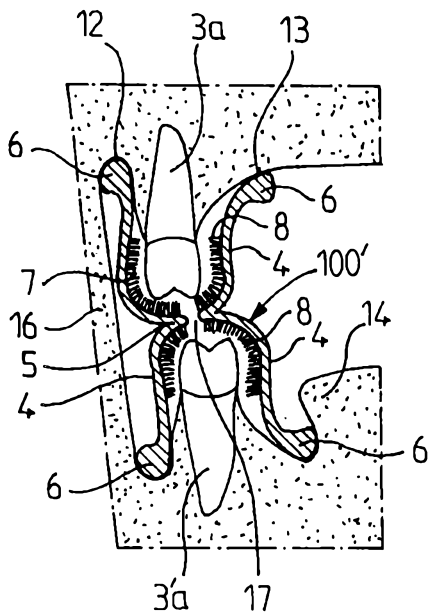

FIG. 9

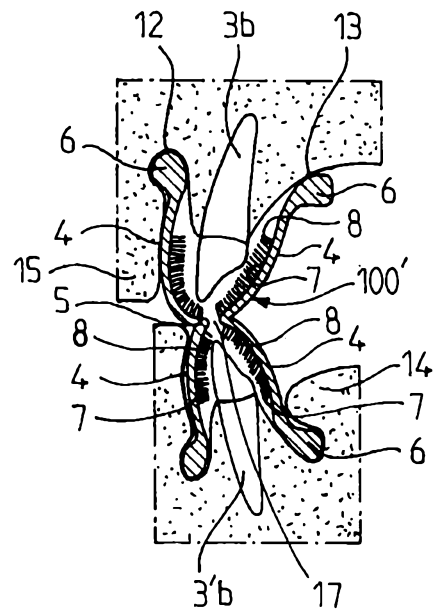

FIG. 10

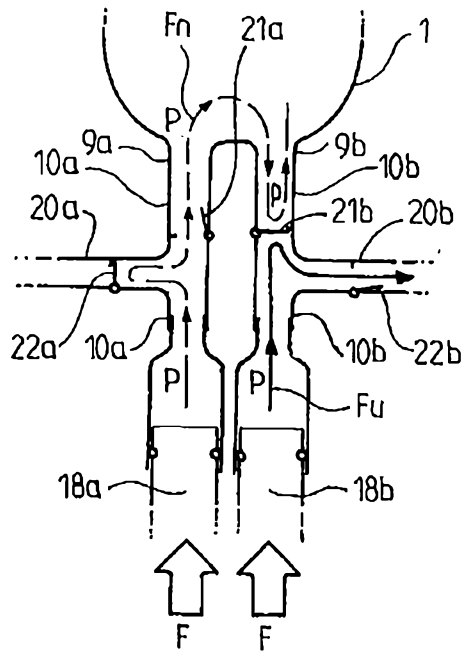

FIG.11

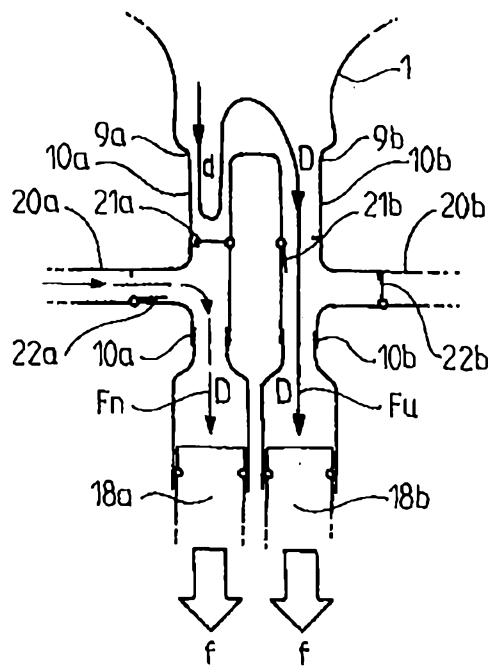

FIG.12

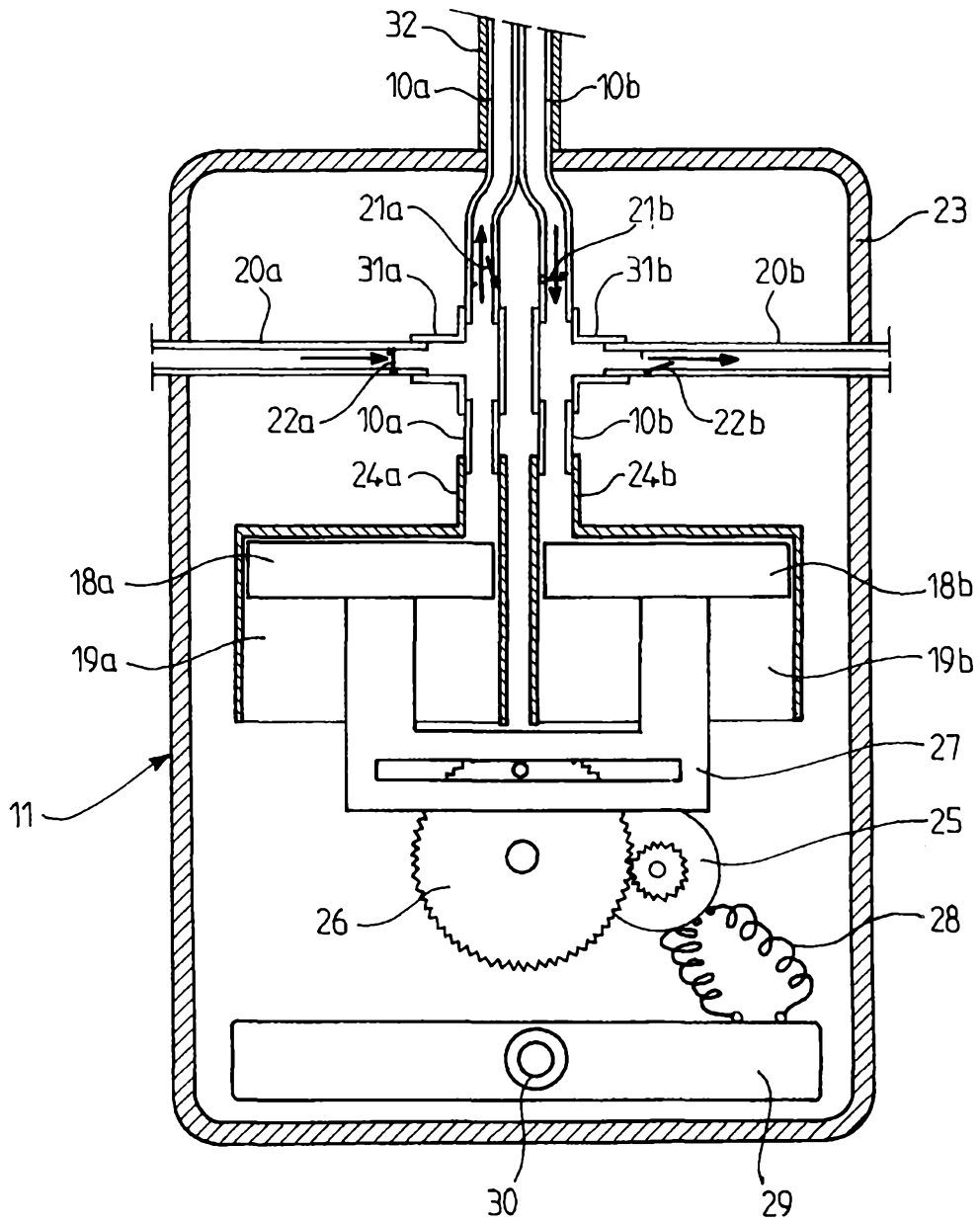

FIG.13