

C. F. BOSWORTH.
Machine for Sewing Straw-Braid.
No. 216,504. Patented June 17, 1879.

Fig 1

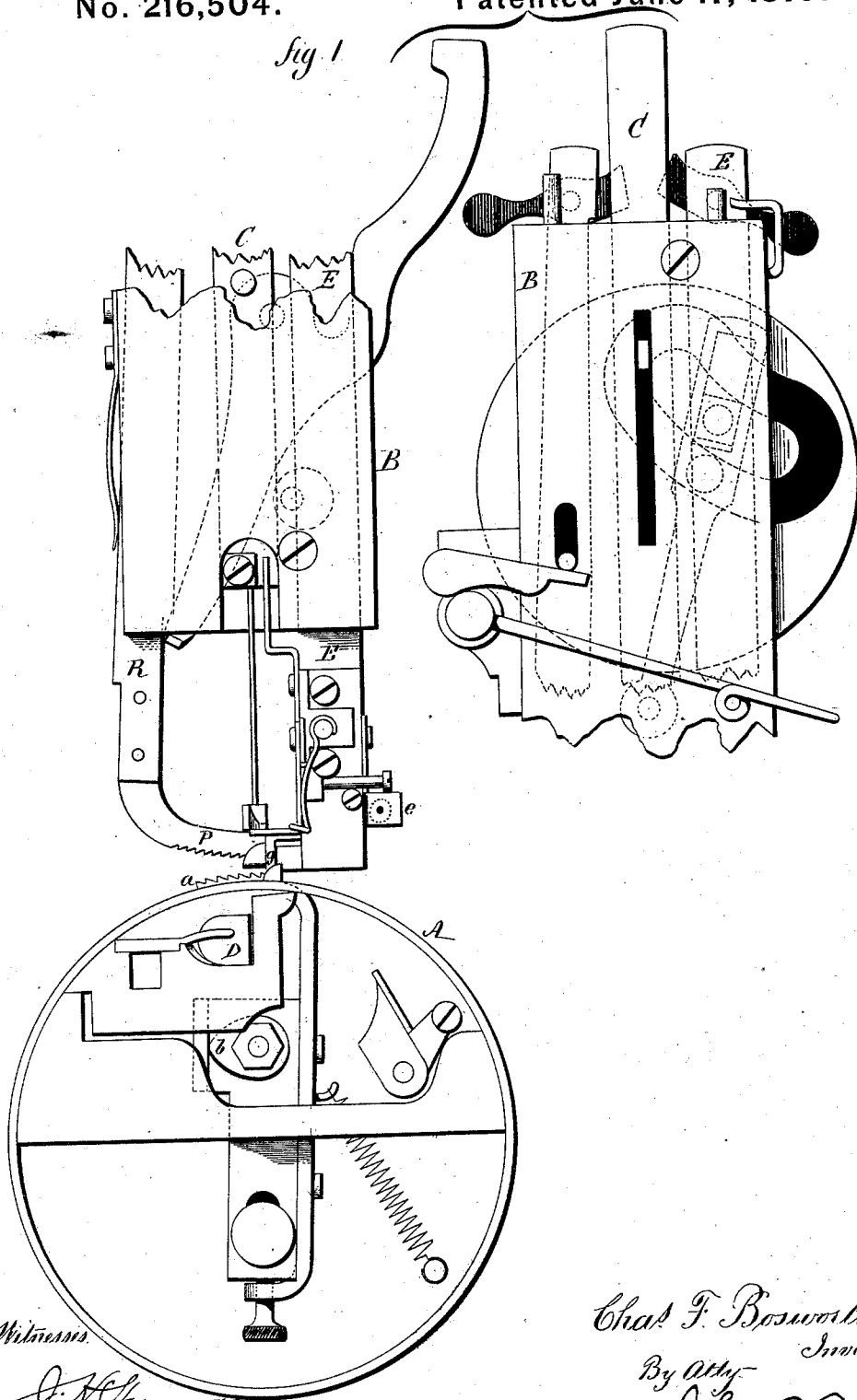

Witness.

J. A. Channing
Geo. A. Kittred.

Chas F. Bosworth
Inventor.

By Atty
Wm S. Earle

C. F. BOSWORTH.
Machine for Sewing Straw-Braid.
No. 216,504. Patented June 17, 1879.

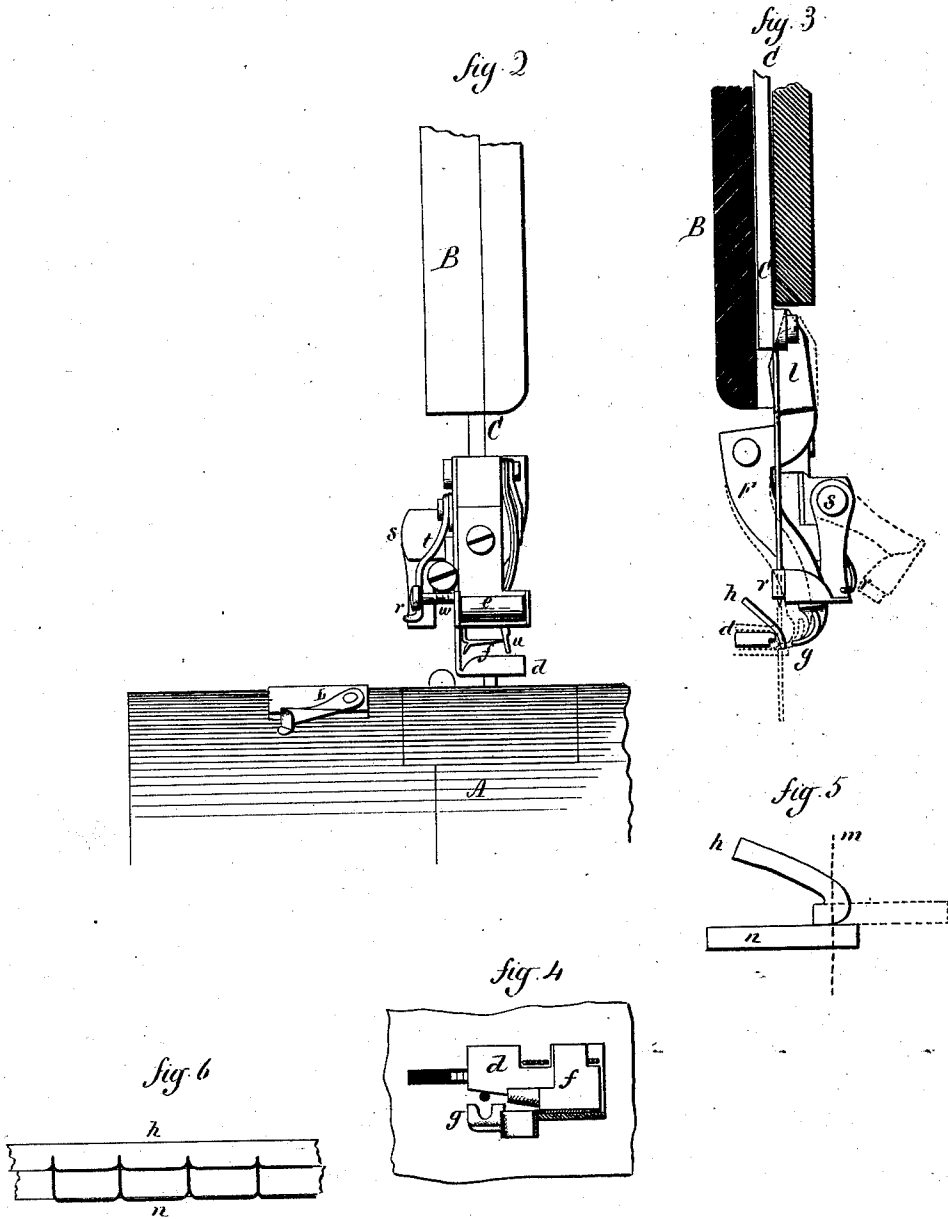

Witnesses
J. A. Murray
Chas. A. Ketchum

Chas. F. Bosworth
 By Atty. *Wm. H. Wade*
 Inventor

UNITED STATES PATENT OFFICE.

CHARLES F. BOSWORTH, OF MILFORD CONNECTICUT.

IMPROVEMENT IN MACHINES FOR SEWING STRAW BRAID.

Specification forming part of Letters Patent No. 216,504, dated June 17, 1879; application filed July 18, 1877.

To all whom it may concern:

Be it known that I, CHARLES F. BOSWORTH, of Milford, in the county of New Haven and State of Connecticut, have invented a new Improvement in Machines for Sewing Straw Braids; and I do hereby declare the following, when taken in connection with the accompanying drawings and the letters of reference marked thereon, to be a full, clear, and exact description of the same, and which said drawings constitute part of this specification, and represent, in—

Figure 1, a front-end view of the machine; Fig. 2, a side view of the portion adjacent to the work-table; Fig. 3, a section through the head, looking toward the needle; Fig. 4, a transverse section above, and so as to show the presser-foot; and Figs. 5 and 6, diagrams for illustration.

This invention relates to an improvement in machines specially adapted for sewing straw braids or other narrow strips, as for the manufacture of hats, caps, &c.

In the machine for this purpose generally used, and for which Letters Patent were granted to me June 9, 1863, No. 38,807, the strip to be sewed is bent transversely, and presented in a folded condition between the point of the needle and the braid to which it is to be sewed, so that the needle and the thread it carries enters the transversely bent or folded piece on the face or side which is to lie upon the other piece or braid to which it is to be sewed, and the needle continuing its movement leaves the first piece of braid on the same side or surface at which it entered, and then in its further movement penetrates from side to side through the second braid, to which the first is to be secured, and the needle-loop locked by a shuttle-thread or otherwise, and so that the thread uniting the braid appears but little, if at all, on the surface of the braid which is to form the outer side of the hat, or, if at all, to a much less extent than on the under surface.

The result of the stitch thus made through this transverse bend is, that the distance between successive punctures or stitches in the second or under braid is considerably greater than between the two corresponding punctures in the bent braid or strip being sewed;

hence, there is difficulty in making a firm stitch. The long stitch will yield more transversely than it would did the punctures in the two braids correspond to each other as to distance apart—that is to say, as would be the case were the braid sewed through and through.

The object of this invention is to accomplish the same result, so far as the hidden stitch is concerned, and yet avoid the loose stitch; and it consists in the construction hereinafter described, and particularly recited in the claims.

This invention is applicable, under certain changes of form, to most of the sewing-machines now in use and making different varieties of stitch; but for convenience of illustration the invention is shown as applied to a machine having a vertically-moving needle-bar and a horizontal shuttle.

A, the work-table here represented, is of a cylindrical form; B, the head, within which the needle-bar C is arranged in the usual manner. Below the work-table a shuttle, D, is also arranged, to operate, in combination with the needle, in substantially the usual manner for this class of machines. There is also the usual feed *a*, operated by a cam, *b*, and adjustable in the usual manner.

E is a vertical bar corresponding to the usual presser-bar, and arranged to be moved up and down in the usual manner. On the lower end of this bar the presser-foot *d* is attached. Between this presser-foot and the work-table the strip, braid, or material to which a strip is to be attached is passed and held down upon the work-table. Above the presser-foot a roll, *e*, is arranged as a preliminary guide for the braid to be sewed; thence the braid is run through a conductor, *f*, of which the presser-foot forms the lower part, the braid running down over the edge of the presser-foot, as seen in Fig. 3, *h* indicating the braid. The path of the needle is in close proximity to the edge of the presser-foot, as seen in Fig. 4; hence the braid at the edge nearest the needle is bent or turned downward.

In order to carry that edge of the braid back beneath the presser-foot, a lever, F, is hung to the presser-bar E, its lower end terminating in a finger, *g*, as seen in Figs. 3 and 4, the finger forked, as seen in Fig. 4, so that as the

finger is moved toward the presser-foot *d* the notch in the finger *g* will allow the ends of the finger to pass beyond without interfering with the needle.

The upper arm, *l*, of the lever *F* in its normal condition stands in the path of the needle-bar *C* or a projection thereon, so that when the needle descends, and before it enters the braid, the finger *g* will be forced toward the presser-foot, against the edge of the braid *h*, and turn the braid under the edge of the presser-foot, as indicated in broken lines in Fig. 3. In this bent condition of the braid the needle enters near the bend, and passes out through the bend on the same surface of the braid which it entered, then directly through the braid below, as indicated in Fig. 5, where the bent braid and the braid to which it is being stitched are shown enlarged, the line *m* indicating the needle and *n* the lower braid. As the work passes from the machine the braid *h* turns over into substantially the same plane as the lower braid, *n*, as indicated in broken lines, Fig. 5.

It will be seen that the bent braid passes from the machine with that surface up which was the lower surface when the braid was introduced to the guide *f*; hence this braid or strip to be sewed must be introduced with that which is to be the under surface up.

To prevent the needle glancing from the braid a guide, *r*, is applied near the braid, through which the needle passes. This guide is hinged at a point, *s*, above, so that it may be turned outward—as for the purpose of setting the needle—and is provided with a spring, *t*, to hold it in its proper position to guide the needle, but yet allow it to be turned away, as occasion may require.

The guide *f* is made adjustable for different width of braid by making its inner edge, *u*, movable and in connection with the adjusting-screw *w*.

An auxiliary upper feed, *P*, is arranged to work on the upper surface of the presser-foot and engage directly with the braid being intro-

duced. This feed is attached to vertical feed-bar *R*, operated from a cam from the driving-shaft, as indicated in Fig. 1, and working simultaneously with the lower or usual feed, which engages directly with the under braid. The upper feed holding the entering braid down upon the presser-foot, as indicated in broken lines, Fig. 3, insures a short and sharp bend, and the two feeds working simultaneously insure the regular movement of the work, the upper feed made adjustable independent of the lower, and adjusted so that a varying feed may be given to the two, if desired.

The usual guide for the strip or material to which the braid is being stitched is applied. (Represented at *l*, Fig. 2, as turned away for convenience of illustration.)

The peculiarity of the stitch made by this longitudinal bend and its advantages will be seen by reference to Fig. 6, a longitudinal section of the two strips of braid stitched together, as shown, enlarged, the distances between the punctures of the needle being identical in both braids.

Having described my invention, I claim—

1. The combination, with sewing mechanism, of mechanism adapted to guide straw or other plaited braid and present it in a longitudinally bent or folded condition between the point of the needle and the braid upon the face of which it is to be sewed, substantially as described.

2. In combination, the presser-foot or guide over which the braid is longitudinally bent and the reciprocating finger for turning the edge of the braid beneath the said presser-foot or guide, substantially as described.

3. The combination of the presser-foot or guide over which the braid is longitudinally bent with a feeding device above and another below the said presser-foot or guide, substantially as described.

CHARLES F. BOSWORTH.

Witnesses:

JOHN E. EARLE,
H. A. KITSON.