



INTERNATIONAL APPLICATION PUBLISHED UNDER THE PATENT COOPERATION TREATY (PCT)

<p>(51) International Patent Classification ⁵ : A61B 19/00, A61F 2/02, 2/28 A61F 2/30</p>	<p>A1</p>	<p>(11) International Publication Number: WO 94/07425 (43) International Publication Date: 14 April 1994 (14.04.94)</p>
<p>(21) International Application Number: PCT/US93/09244 (22) International Filing Date: 29 September 1993 (29.09.93) (30) Priority data: 07/953,475 29 September 1992 (29.09.92) US (71) Applicant: SMITH & NEPHEW RICHARDS INC. [US/ US]; 1450 Brooks Road, Memphis, TN 38116 (US). (72) Inventor: DAVIDSON, James, A. ; 2573 Windy Oaks Drive, Germantown, TN 38139 (US). (74) Agents: KRIEGER, Paul, E. et al.; Pravel, Hewitt, Kimball & Krieger, Tenth Floor, 1177 West Loop South, Houston, TX 77027-9095 (US).</p>		<p>(81) Designated States: AU, CA, JP, European patent (AT, BE, CH, DE, DK, ES, FR, GB, GR, IE, IT, LU, MC, NL, PT, SE). Published <i>With international search report. Before the expiration of the time limit for amending the claims and to be republished in the event of the receipt of amendments.</i></p>
<p>(54) Title: OSTEOINDUCTIVE BONE SCREW</p>		
<p>(57) Abstract</p> <p>A bone screw (19) and its method of manufacturing provides a low modulus osteoinductive bone screw with a high resistance to insertion torquing. The method includes the steps of pre-torquing a plurality of reinforcing fibers (23), molding a polymer matrix to bond with the pre-torqued fibers, and whereing the screw apparatus is coated with an osteoinductive material such as hydroxyapatite or calcium phosphate.</p> <div data-bbox="957 1254 1404 2016" data-label="Image"> </div>		

FOR THE PURPOSES OF INFORMATION ONLY

Codes used to identify States party to the PCT on the front pages of pamphlets publishing international applications under the PCT.

AT	Austria	FR	France	MR	Mauritania
AU	Australia	GA	Gabon	MW	Malawi
BB	Barbados	GB	United Kingdom	NE	Niger
BE	Belgium	GN	Guinea	NL	Netherlands
BF	Burkina Faso	GR	Greece	NO	Norway
BG	Bulgaria	HU	Hungary	NZ	New Zealand
BJ	Benin	IE	Ireland	PL	Poland
BR	Brazil	IT	Italy	PT	Portugal
BY	Belarus	JP	Japan	RO	Romania
CA	Canada	KP	Democratic People's Republic of Korea	RU	Russian Federation
CF	Central African Republic	KR	Republic of Korea	SD	Sudan
CG	Congo	KZ	Kazakhstan	SE	Sweden
CH	Switzerland	LI	Liechtenstein	SI	Slovenia
CI	Côte d'Ivoire	LK	Sri Lanka	SK	Slovak Republic
CM	Cameroon	LU	Luxembourg	SN	Senegal
CN	China	LV	Latvia	TD	Chad
CS	Czechoslovakia	MC	Monaco	TC	Togo
CZ	Czech Republic	MG	Madagascar	UA	Ukraine
DE	Germany	ML	Mali	US	United States of America
DK	Denmark	MN	Mongolia	UZ	Uzbekistan
ES	Spain			VN	Viet Nam
FI	Finland				

OSTEOINDUCTIVE BONE SCREW**BACKGROUND OF THE INVENTION:****1. Field Of The Invention:**

5 The present invention relates to surgical devices,
namely orthopedic bone screws and more particularly to a
high torque, low modulus, osteoinductive bone screw
article and a method of making said bone screw wherein
the screw is polymeric with an interval fiber
10 reinforcement, the fibers being pre-torqued prior to and
during a curing or molding with a polymer matrix. The
polymer matrix is used to bond with the pre-torqued
fibers in the shaft and head regions of the bone screw,
and the outer surface of the pre-torqued fiber reinforced
15 polymer screw can be coated with an osteoinductive
material such as hydroxyapatite or calcium-phosphate
material.

↑
BMP, GROWTH FACTORS,

Jordan
4/22/92

2. General Background:

Metal bone screws are routinely used to attach bone plates or to fix fractured bone fragments or tissue to bone. Most commonly used are bone screws made of 316L stainless steel. Stainless steel has an elastic modulus of about thirty (30) million p.s.i. significantly greater than that of cortical bone (about two (2) million p.s.i.). The presence of a hole in cortical bone acts as a stress concentrator and can weaken the bone. For example, Edgerton, et al. (J. Ortho. Res., 8,851-855, 1990) have shown that a hole size equal to twenty (20) percent of the bone diameter can reduce torsional strength by about thirty four percent (34%).

When steel screws are removed from plated femurs or tibias after fracture healing, the bone often fractures at the open hole remaining upon removal of the screw. Although the tendency for bone fracture may be less with the steel screw in the bone (i.e. filling the hole) the mismatch in elastic modulus between the steel screw and bone can still produce a certain level of stress concentration. A low modulus screw could be left in place and not allow stress shielding of the bone from the presence of the bone plate. The plate (even metal) would maintain acceptable axial and torsional motion at the bone fracture for healing, but because the attachment screws are of low modulus, flexion of the screw can occur allowing load to transfer through the healed bone in a near-normal fashion. Thus a second surgery to remove the device and screws would not be necessary. A bone screw of low modulus poses a smaller stress concentrator in the

bone, thus bone integrity would be similar to that of bone without the bone screws present.

BMP, GROWTH FACTORS,

JSD
9/22/92

5 To further assure a minimal or nonexistent reduction in bone strength from the presence of the low modulus screw, the screw or other type of anchoring device could be coated or bonded with hydroxyapatite or another effective osteoinductive (osteogenic) material to fully integrate the surrounding bone with the low modulus screw, further reducing any remaining stress concentration effects.

10 Various patents have been issued which discuss self-reinforced, absorbable materials having reinforcing elements that are would at least partially around some axis pertaining to the implant. For example, U.S. Patent 15 4,968,317 describes a resorbable material in which the reinforcing elements are formed by fibrillating a sheet of the reinforcing material by drawing it.

20 U.S. Patent 4,743,257 describes a resorbable material in which the reinforcing elements are parallel threads of the same chemical composition as the rest of the implant. U.S. Patent 4,743,257 describes an osteosynthesis composite material which is at least partially absorbable in living tissue. This material 25 comprises an absorbable polymer of copolymer matrix which is reinforced with absorbable polymeric reinforcement elements which have the same chemical element percentage composition as does the matrix. The reinforcing element is shown as parallel threads of polymer. International patent application 90/12550 describes a self-reinforced 30 absorbable surgical material characterized in that the reinforcing elements are wound at least partially around

some axis penetrating the implant. The spiral orientation of the reinforcing elements is claimed to allow the screws to resist higher torque forces than known parallel thread or non-reinforced screws.

5 In surgery it is known to use implants, or their parts or components, which are manufactured at least partially of an absorbable polymer and/or of a polymer composite containing reinforcing elements, for fixation of bone fractures, osteotomies or arthrodeses, joint
10 damages, tendon and ligament damages etc. Such implants are e.g. rods, screws, plates, intramedullary nails and clamps, which have been described in the professional literatures of material technique and medicine.

U.S. Patent No. 3,620,218, entitled "Cylindrical
15 Prosthetic Devices of Polyglycolic Acid" and U.S. Patent No. 3,739,733 entitled "Polyglycolic Acid Prosthetic Devices, both issued to E. Schmitt and R. Polistina, describe implants like rods, screws, plates, and cylinders which have been manufactured of polyglycolic
20 acid.

U.S. Patent No. 4,052,988 issued to N. Doddi, C. Versfelt and D. Wasserman, entitled "Synthetic Absorbable Surgical Devices of Polydioxanone" describes absorbable
25 sutures and other surgical devices manufactured of polydioxanone.

U.S. Patent No. 4,279,249 issued to M. Vert, F. Chabot, J. Leray and P. Christel, entitled "New Prosthesis Parts, Their Preparation and Their
30 Application" describes osteosynthesis devices which have been manufactured of polylactide or of copolymer containing plenty of lactide units, which matrix has been

reinforced with reinforcing elements which have been manufactured of polyglycolide or of copolymer including mainly glycolic acid units.

5 DE 2947985 A 1, issued to S. Belych, A. Davydov, G. Chromov, A. Moscenskij, I. Movsovic, G. Rojtberg, G. Voskresenskij, G. Persin and V. Moskvitin, entitled "Biodestruktiver Stoff für Verbindungselemente für Knochengewebe" describes at least partially degradable composites which comprise a copolymer of
10 methacrylate and N-vinylpyrrolidone, which has been reinforced with polyamide fibers or with oxycellulose fibers.

U.S. Patent No. 4,243,775, issued to M. Rosensaft and R. Webb, entitled "Synthetic Polyester Surgical
15 Articles" describes surgical products manufactured of copolymer of glycolic acid and trimethylene carbonate.

U.S. Patent No. 4,329,743, issued to H. Alexander, R. Parsons, I. Strauchler and A. Weiss, entitled "Bioabsorbable Composite Tissue Scaffold" describes a
20 composite of a bio-absorbable polymer and carbon fibers, which composite is suitable for manufacturing surgical articles.

U.S. Patent No. 4,343,931, issued to Barrows, entitled "Synthetic Absorbable Devices of
25 Poly(esteramides)" describes absorbable polyesteramides, which are suitable for manufacturing of surgical implants.

Patent Application EPO 0,146,398, issued to R. Dunn and R. Casper entitled "Method of Producing Biodegradable
30 Prosthesis and Products therefrom" describes a method for manufacturing of biodegradable prostheses about

biodegradable polymer matrix which is reinforced with biodegradable ceramic fibers.

WO 86/00533, issued to J. Leenslag, A. Pennings, R. Veth and H. Jansen entitled "Bone Implant" describes an
5 implant material for reconstructive surgery of bone tissue, which material comprises a biodegradable porous polymer material and biodegradable or biostable fibers.

The publication of D. Tunc, "A High Strength Absorbable Polymer for Internal Bone Fixation", 9th
10 Annual Meeting of the Society for Biomaterials, Birmingham, Alabama, April 27-May 1, 1983, p. 17, describes a high strength absorbable polylactide, with an initial tensile strength about 50-60 MPa and which material retains a significant part of its initial
15 strength 8-12 weeks after the implantation. This material can be considered suitable to be applied as basic material in manufacturing of internal bone fixation devices which are totally absorbable in living tissues.

The publication of D. Tunc, M. Rohovsky, W. Lehman,
20 A. Strogwater and F. Kummer entitled "Evaluation of Body Absorbable Bone Fixation Devices", 31st Annual ORS, Las Vegas, Nevada, January 21-24, 1985, p. 165, describes high strength, totally absorbable polylactide (initial strength 57,1 MPa), which was used as plates and screws
25 for fixation of canine radial osteotomies.

The publication of D. Tunc, M. Rohovsky, J. Zadwadsky, J. Speiker and E. Strauss entitled "Evaluation of Body Absorbable Screw in Avulsion Type Fractures", the
30 12th Annual Meeting of the Society for Biomaterials, Minneapolis - St. Paul, Minnesota, USA, May 29 to June 1, 1986, p. 168, describes the application of high strength

polylactide screws in fixation of avulsion-type fractures (fixation of canine calcaneus osteotomy).

U.S. Patent No. 4,776,329 issued to R. Treharne entitled "Resorbable Compressing Screw and Method",
5 describes a compression screw comprising a non-absorbable compression parts and a screw. At least the head of the screw comprises material, which is resorbable in contact with tissue fluids.

Self-reinforced absorbable fixation devices have
10 significantly higher strength values than the non-reinforced absorbable fixation devices. U.S. Patent No. 4,743,257 issued to P. Törmälä, P. Rokkanen, J. Laiho, M. Tamminmäki and S. Vainionpää entitled "Material for Osteosynthesis Devices", describes a self-reinforced
15 surgical composite material, which comprises an absorbable polymer or copolymer, which has been reinforced with absorbable reinforcing elements, which have the same chemical element composition as the matrix.

FI Patent Application No. 87 0111, issued to P.
20 Törmälä, P. Rokkanen, S. Vainionpää, J. Laiho, V.-P. Heponen and T. Pohjonen entitled "Surgical Materials and Devices", describes self-reinforced surgical bone fracture fixation devices which have been manufactured at least partially of fibrillated absorbable material(s).

25 According to the publication of T. Pohjonen, P. Törmälä, J. Mikkola, J. Laiho, P. Helevirta, H. Lähde, S. Vainionpää and P. Rokkanen entitled "Studies on Mechanical Properties of Totally Biodegradable Polymeric Rods for Fixation of Bone Fractures", VIth International
30 Conference PIMS, Leeuwenhorst Congress Center, Holland, 12-14 April 1989, p. 34/1-34/6, self-reinforced

absorbable surgical materials have excellent strength properties, e.g. SR-polyglycolide had bending strength 415 MPa and SR-poly lactide 300 MPa.

5 In the publication of D. Tunc and J. Jadhav entitled "Development of Absorbable Ultra High Strength Polylactide", Am. Chem. Soc., 196th ACS Meeting, Abstracts of Papers, L.A., California, Sept. 25-30, 1988, p. 383-387, a good tensile strength (300 MPa) for fibrillated SR-poly lactide was measured.

10 The publication of E. Partio, O. Böstman, S. Vainionpää, H. Pättälä, E. Hirvensalo, K. Vihtonen, P. Törmälä and P. Rokkanen entitled "The Treatment of Cancellous Bone Fractures with Biodegradable Screws", Acta Orthop. Scand., 59(5), 1988, p. 18, describes the
15 fixation of cancellous bone fractures with self-reinforced absorbable screws, which have a flat head, which head can be located to a slot at the tip of the screwdriver in order to drive the screw into a channel made into the bone.

20 The following patents relate to absorbable (biodegradable or resorbable) polymers, copolymers, polymer mixtures, or composites:

U.S. Patent No. 3,297,033; U.S. Patent No. 3,636,956,
U.S. Patent No. 4,052,988; U.S. Patent No. 4,343,931;
25 U.S. Patent No. 3,969,152; U.S. Patent No. 4,243,775; FI Patent Appln. No. 85 5079, FI Pat. Appln. No. 86 0366; FI Patent Appln. No. 86 0440 and FI Pat. Appln. No. 88 5164.

SUMMARY OF THE PRESENT INVENTION:

30 The present invention provides an improved method of manufacturing a low modulus bone screw with a high

resistance to insertion torque. The method includes a pre-torquing of a plurality of reinforcing fibers, a polymer matrix is molded to bond with pre-torqued fibers and the screw can be coated with an osteoinductive material.

The bone screw formed by the method of the present invention provides an improved bone screw with an elongated shaft portion, and can have an enlarged head portion at one end of the shaft, the bone screw being coated with an osteoinductive material such as hydroxyapatite, calcium phosphate or the like for example.

*BMP - GROWN FROM
JED:sk
9/24/92*

The bone screw thus formed by the method of the present invention provides a bone screw with a transverse modulus of elasticity of between about six and fifty GPa., i.e. the effective modulus of the screw when loaded transversely as opposed to longitudinally.

To reduce or eliminate the stress concentration effects of metal bone screws and holes in the bone, to optimize strength of a low-modulus bone screw to allow more reliable insertion and bone fracture stability, and to eliminate the need for a second surgery to remove the implant, a pre-torqued, low-modulus, fiber reinforced polymer matrix bone screw is proposed with or without an hydroxyapatite or other osteogenic material incorporated onto the surface to bond the screw to the bone. A biocompatible high strength fiber and polymer matrix material can be used to construct the bone screw of the present invention described more fully hereinafter.

Fibers are aligned in an uniaxial or longitudinal direction and impregnated with a self-curing or heat

curing polymer, or co-mingled with a thermoplastic fiber or powder. The bundle of fibers is passed through an appropriate molding die and fanned out at the top end of the die which is also used to form the head portion of
5 the bone screw.

The fibers at the top are tightly fixed to the die. The fibers are then turned tightly in the direction which will oppose the applied torque during insertion of the final molded bone screw. Fabric and other woven forms of
10 fibers or pre-braided fibers can also be used versus just uniaxial fibers. The torque should be sufficient to allow acceptable insertion into the bone, following molding or curing of the polymer matrix, without failure of the screw head or shaft. The head and thread regions
15 can be finished with pure polymer or random-fiber reinforced polymer.

Because the fibers are pre-torqued in the direction that the torque will be applied during insertion, these fibers will be able to carry the same (or higher) level
20 of torque without breaking when inserted into the bone. Because they are pre-loaded along the screw axis, the screw will be resistant to loading and fracture under the screw head. Circumferentially wound fiber can also be added to the head region to further improve resistance to
25 torque during insertion by the screw driver or like driving implement. Both of these problems currently renders the use of existing resorbable polymer screws to fixation of very low-stress fractures, as screw failure can readily occur.

30 Because of the low modulus and minimal stress concentration effects, the present pre-torqued bone screw

is designed to remain in the bone without the need for a second surgery. Even if a metal bone plate is used, the low modulus neck region of the pre-torqued screw will flex and not allow stress shielding at the healed bone fracture to occur as is the case with current metal screws. Thus even a metal bone plate attached by the pre-torqued bone screws may be left in place and thereby avoiding a second surgery.

Left in place, the low modulus-pretorqued bone screw with a bioactive (osteoinductive) surface will not produce the undesirable level of stress concentration in the bone (and subsequently weaken the bone) as currently produced by metal screws such as stainless steel. Most importantly, the pre-torqued method of manufacture will enable such effective low-modulus bone screws to be reliably inserted into the bone without the high incidence of breakage which limits currently made low-modulus polymer or polymer matrix bone screws.

BRIEF DESCRIPTION OF THE DRAWINGS:

For a further understanding of the nature and objects of the present invention, reference should be had to the following detailed description taken in conjunction with the accompanying drawings, in which like parts are given like reference numerals, and wherein:

FIGURE 1 is a schematic perspective view illustrating the die and fibers used with the method of the present invention, and particularly the step of aligning the fibers in a uniaxial direction in a die;

FIGURE 2 is a sectional schematic view illustrating the die and the fibers aligned in a uniaxial direction

prior to the torquing step of the method of the present invention;

FIGURE 3 is a schematic perspective view illustrating the method of the present invention in the twisting of fibers to pre-torque them prior to a molding of a polymer matrix to the pre-torqued fibers;

FIGURE 4 is a sectional schematic view illustrating the pre-torquing of fibers as part of the method of the present invention;

FIGURE 5 is a schematic view illustrating test results of the torquing of a simulated bone with an opening in the simulated bone;

FIGURE 6 is a schematic view illustrating test results of the torquing of a simulated bone, and with a metallic bone screw occupying an opening in the bone; and

FIGURE 7 is a schematic view illustrating test results of the torquing of a simulated bone, and with a bone screw occupying an opening in the bone wherein the bone screw has a modulus that is similar to that of the bone.

DETAILED DESCRIPTION OF THE PREFERRED EMBODIMENT:

Figures 1-4 illustrate the method of the present invention wherein a low modulus bone screw with high resistance to insertion torquing is formed. In Figure 1, die 10 is generally cylindrically shaped having a central longitudinal and open ended cavity 11. The die 10 includes an upper flat surface 12 and a lower flat surface 13. Bore 11 is open-ended, communicating with upper opening 14 and lower opening 15.

The cavity 11 of die 10 is shaped to define the shape of the low modulus bone screw which is formed using the method of the present invention. The cavity 11 includes a threaded section 16 with a continuous helical thread pattern for forming a bone screw thread, a cylindrical, unthreaded section 17, and a frustroconical upper section 18 that is designed to form the head of the screw. Die 10 has a generally cylindrically shaped outer wall 19 which can be gripped and turned during a twisting of fibers 20 to pre-torque them to a level acceptable for screw insertion into the bone of a patient during surgery. In Figures 1-2, fibers 20 are shown axially aligned and concentrated together in a group. The fibers 20 extend through cavity 11 in the aligned fashion as shown in Figures 1 and 2. Fibers 20 are spread out in the frustroconical section 18 that forms the screw head region, with the upper end portion 21 of each fiber 20 radially extending away from cavity 11 and abutting flat surface 12 as shown in Figures 1 and 2. Die 10 is then twisted in the direction of arrow 22 (see Figure 3) while the lower end 23 of fibers 20 are fixed at fixed support 24. In Figure 4, the circumferentially wound fibers 20 are shown after twisting in order to pre-torque them. The circumferentially wound fibers 20 help absorb the head torque from a screwdriver or like implement as generated during surgical insertion of the bone screw. The head 18 and thread 16 regions of cavity 11 define a space of desired volume for polymer fill between die 10 and fibers 20. In Figure 4, the space between wound fibers 20 and die 10 is designated by the numeral 25. Bone screw S is outlined in phantom lines in Figure 4.

The bone screw S typically comprises a cylindrical shank portion 26, a helical thread portion as defined by threaded section 16 of die 10, a head portion H, and may have a lower pointed tip T. The shank can comprise an inner most isotropic metallic core integral with the head H, and covered with the low modulus polymer ~~matrix~~ *matrix* *Asst Dir*

Because the fibers are pre-torqued in the direction that the torque will be applied during insertion, these fibers will be able to carry the same (or higher) level of torque without breaking when inserted into the bone. Because they are pre-loaded along the screw axis, the screw will be resistant to loading and fracture under the screw head. Circumferentially wound fiber can also be added to the head region to further improve resistance to torque during insertion by the screw driver or like driving implement. Both of these problems currently renders the use of existing resorbable polymer screws to fixation of very low-stress fractures, as screw failure can readily occur. *9/22/92*

Figures 5, 6 and 7 are photographs that demonstrate the results of a torsion test that demonstrates the effect of holes and filled holes on stress concentration. To demonstrate the effect of holes and filled holes on stress concentration, 6 mm diameter holes were drilled in 18 mm diameter wood cylinders (15 cm long) with a wall thickness of 2.5 mm. In one case the hole was left unfilled (Figure 5). In another case, a hard metal ^{STAINLESS STEEL} dowel was press-fit into the hole (Figure 6). In the final case, a low modulus (wood) dowel was press-fit and glued (epoxy) into the hole to simulate a bioactive material (hydroxyapatite) coated-low modulus screw (Figure 7). *Asst Dir*
9/22/92

The samples were loaded in torsion in a Bionix MTS machine and compared to tests in which no hole was present. The wood cylinders were filled with a wood insert (1.5 cm long) for gripping at each end. Results are given below in Table 1, and show the dramatic reduction (48%) in strength due to the hole. Importantly, this reduction in strength is still present with a pressed steel dowel (i.e., bone screw), while the glued, low modulus, wood dowel completely restores the strength.

Figures 5, 6, and 7 show clearly how the crack initiates at the hole whether unfilled (Figure 5) or filled with the tight stainless steel dowel pin (Figure 6). However, when the pin is an integral part of the wood cylinder, the hole effect can be eliminated and the crack due to torsional loading can initiate anywhere along the cylinder. Notice in Figure 7 that the crack did not initiate from the hole region.

20

TABLE 1. RESULTS OF THE TORSION TESTS

Condition	Average Peak Torque (Nm)	Torsional Energy (Area Under Torque -Rotation Curve) Nm-Deg.	Reduction in Strength
No hole	10.3	75.7	-----
Hole (unfilled)	7.8	39.3	48%
Hole with steel dowel	7.0	33.2	56%
Hole with glued wood dowel	10.7	75.4	<1%

11
12
13
14
15
16
17
18
19
20
21
22

Perhaps even more important is that a permanent,
 low-modulus screw with an osteoinductive coating would
 25 not necessarily have to be removed.

The following table 2 lists the part numbers and
 part descriptions as used herein and in the drawings
 attached hereto.

TABLE 2 - PARTS LIST

	<u>PART NO.</u>	<u>DESCRIPTION</u>
	10	die
	11	cavity
5	12	upper flat surface
	13	lower flat surface
	14	upper opening
	15	lower opening
	16	threaded section
10	17	unthreaded section
	18	frustroconical section
	19	die outer wall
	20	reinforcing fibers
	21	upper end portion
15	22	arrow
	23	lower end of fibers
	24	fixed support
	25	space
	26	cylindrical shank portion
20	S	bone screw
	H	head
	T	lower tip

Because many varying and different embodiments may
 25 be made within the scope of the inventive concept herein
 taught, and because many modifications may be made in the
 embodiments herein detailed in accordance with the
 descriptive requirement of the law, it is to be
 understood that the details herein are to be interpreted
 30 as illustrative and not in a limiting sense.

What is claimed as invention is:

CLAIMS:

- 1 1. A method of manufacturing a low modulus bone
2 screw with a high resistance to insertion torque;
3 comprising the steps of
4 a) pre-torquing a plurality of reinforcing
5 fibers;
6 b) molding a polymer matrix to bond with the
7 pretorqued fibers;
8 c) wherein the fibers are wound in a direction
9 that orients the fibers to resist insertion torque
10 applied to the bone screw.
- 1 2. The method of Claim 1 further comprising the
2 step of coating the screw with an osteoinductive
3 material.
- 1 3. The method of Claim 1 wherein the bone screw
2 has an elongated shaft with an enlarged head at one end
3 portion of the shaft.
- 1 4. The method of Claim 1 wherein the
2 osteoinductive material is hydroxyapatite.
- 1 5. The method of Claim 1 wherein the
2 osteoinductive material is calcium phosphate.
- 1 6. The method of Claim 1 wherein the bone screw
2 modulus of elasticity is between about six and fifty GPa.
- 1 7. The method of Claim 1 wherein in step c, the
2 osteoinductive material is bonded to the outer surface
3 portion of the screw.
- 1 8. The method of Claim 1 wherein in step "b" the
2 polymer matrix is a biocompatible high strength fiber and
3 polymer matrix.

1 9. The method of Claim 1 wherein in step "a" the
2 fibers are preliminarily aligned in a uniaxial direction.

1 10. A method of manufacturing a low modulus bone
2 screw with a high resistance to insertion torque
3 comprising the steps of

4 a) preliminarily aligning a plurality of fibers in
5 a uniaxial direction to form a

6 b) impregnating the fibers with a polymer;

7 c) rotate the fiber ends with respect to one
8 another and in a direction which will oppose the applied
9 torque during insertion of the bone screw; and

10 d) allowing the polymer to harden after rotation
11 of the fibers.

1 11. The method of Claim 9 wherein in step "b" the
2 polymer is a self-curing polymer.

1 12. The method of claim 9 wherein in step "b" the
2 polymer is a heat curing polymer.

1 13. The method of Claim 9 wherein in step "b" the
2 polymer is a thermoplastic powder.

1 14. The method of Claim 9 wherein in step "b",
2 thermoplastic fibers are co-mingled with the aligned
3 fibers.

1 15. The method of Claim 1 further comprising the
2 step of forming polymeric threads on the bone screw.

1 16. The method of Claim 1 further comprising the
2 step of forming fiber reinforced polymer threads on the
3 bone screw.

1 17. The method of Claim 9 further comprising the
2 step of forming a fiber reinforced head portion on the
3 screw.

1 18. The method of Claim 16 wherein the head portion
2 is formed with circumferentially wound fiber
3 reinforcement.

1 19. The method of Claim 9 further comprising the
2 step of coating the screw with an osteoinductive coating.

1 20. The method of Claims 1 or 18 further comprising
2 the step of coating the screw with a porous coating.

1 21. The method of Claim 1 or 9 wherein the fibers
2 are torqued before molding or curing of the polymer
3 matrix.

1 22. A bone screw article formed according to the
2 method of Claim 1.

1 23. A bone screw article formed according to the
2 method of claim 10.

1 24. A bone screw, comprising:

2 a) a shank portion;

3 b) a helical thread wound upon the shank portion;

4 c) a head portion at one end of the shank;

5 d) means on the head portion for transmitting
6 torque to the shank portion; and

7 e) wherein the shank portion is of a polymeric
8 matrix reinforced with fibers that are pre-torqued in a
9 direction that maximizes resistance to insertion torque
10 applied to the bone screw.

1 25. The bone screw of Claim 24 wherein the threads
2 have a surface that is coated with an osteoinductive
3 material.

1 26. The bone screw of Claim 24 wherein the shank is
2 isotropic metal.

an
J. D. Sch
9/22/92

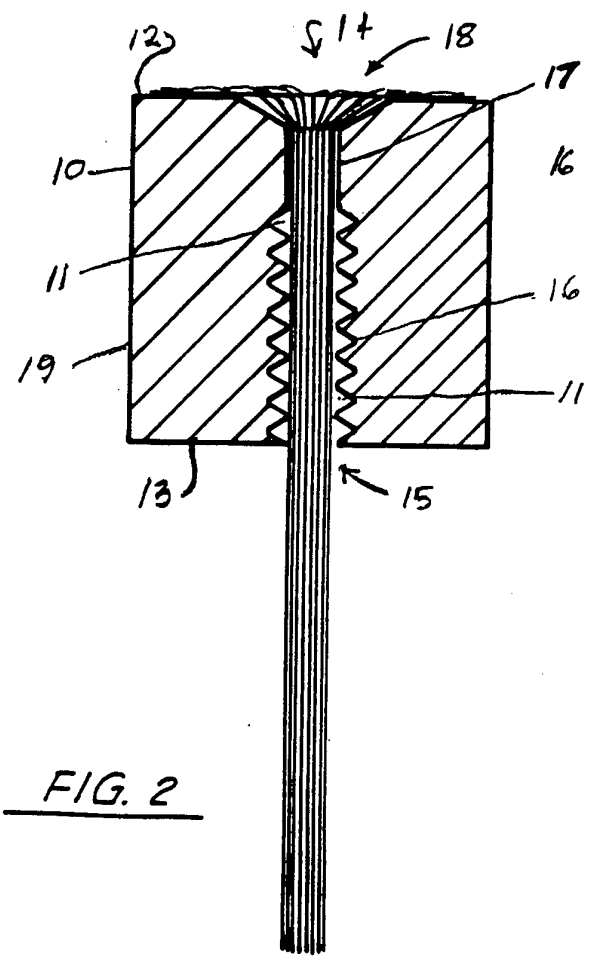
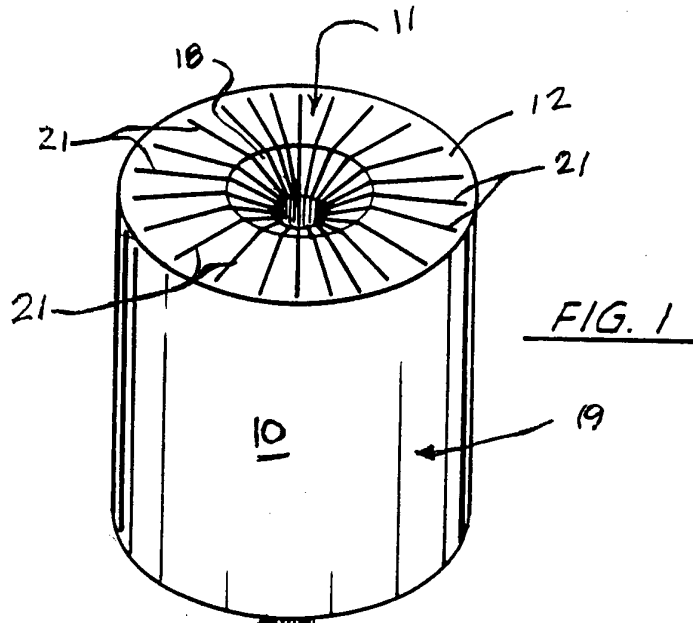

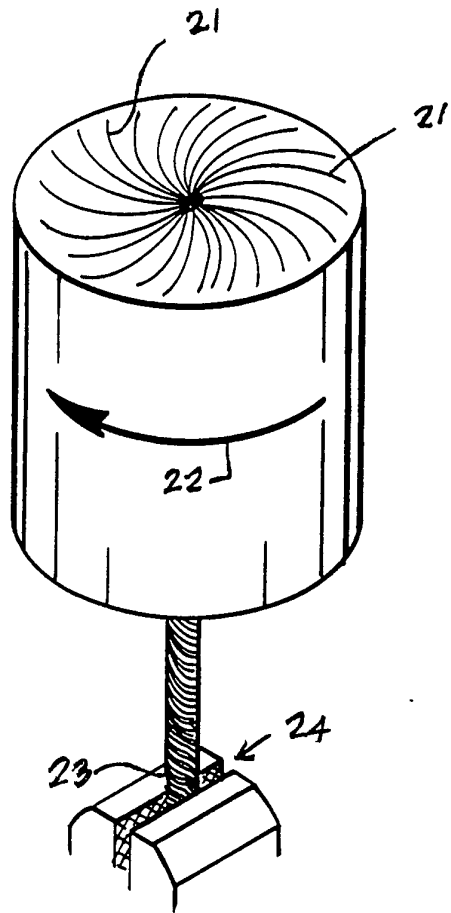

FIG. 3

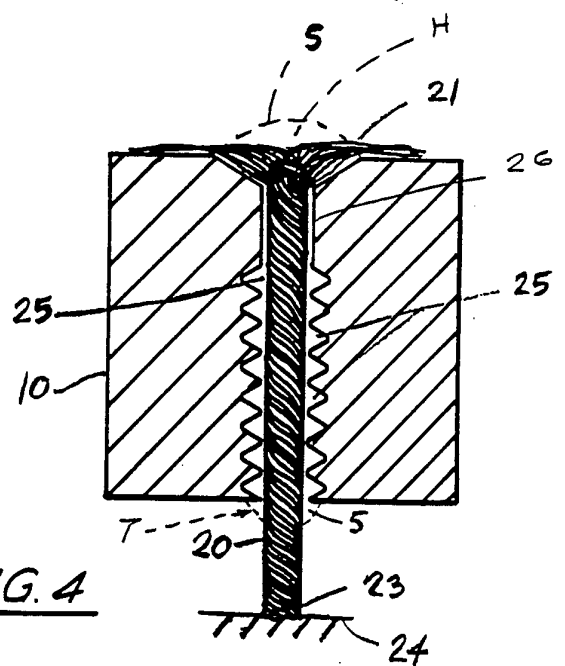

FIG. 4

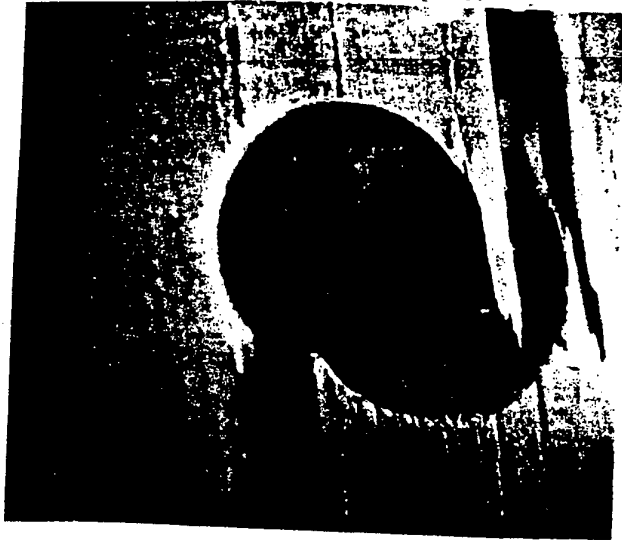

FIG. 5

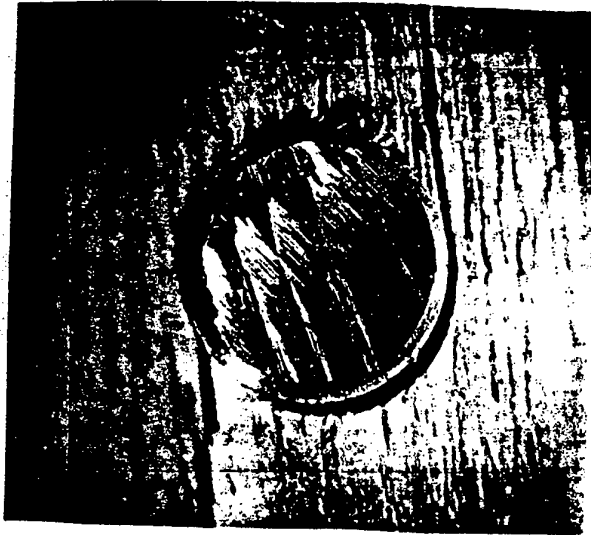

FIG. 6



3/3
FIG. 7

*Original Photos sent to
Patent Office with application.
9/29/92*

INTERNATIONAL SEARCH REPORT

International application No.
PCT/US93/09244

A. CLASSIFICATION OF SUBJECT MATTER
 IPC(5) :A61B 19/00; A61F 2/02, 2/28, 2/30
 US CL :128/898, 897; 623/11, 16, 18, 901; 606/60, 65, 66, 73
 According to International Patent Classification (IPC) or to both national classification and IPC

B. FIELDS SEARCHED
 Minimum documentation searched (classification system followed by classification symbols)
 U.S. : 128/898, 897; 623/11, 16, 18, 901; 606/60, 65, 66, 67, 72, 73

Documentation searched other than minimum documentation to the extent that such documents are included in the fields searched
 NONE

Electronic data base consulted during the international search (name of data base and, where practicable, search terms used)
 NONE

C. DOCUMENTS CONSIDERED TO BE RELEVANT

Category*	Citation of document, with indication, where appropriate, of the relevant passages	Relevant to claim No.
A	US, A, 3,636,956 (Schneider) 25 January 1972, see abstract and figures.	1-9, 11-22
A	US, A, 4,052,988 (Doddi et al.) 11 October 1977, see abstract and figures	1-9, 11-22
A	US, A, 4,743,257 (Tormala et al.) 10 May 1988, see abstract and figures.	1-9, 11-22

Further documents are listed in the continuation of Box C. See patent family annex.

* Special categories of cited documents:	*T	later document published after the international filing date or priority date and not in conflict with the application but cited to understand the principle or theory underlying the invention
A document defining the general state of the art which is not considered to be part of particular relevance	*X*	document of particular relevance; the claimed invention cannot be considered novel or cannot be considered to involve an inventive step when the document is taken alone
E earlier document published on or after the international filing date	*Y*	document of particular relevance; the claimed invention cannot be considered to involve an inventive step when the document is combined with one or more other such documents, such combination being obvious to a person skilled in the art
L document which may throw doubts on priority claim(s) or which is cited to establish the publication date of another citation or other special reason (as specified)	*Z*	document member of the same patent family
O document referring to an oral disclosure, use, exhibition or other means		
P document published prior to the international filing date but later than the priority date claimed		

Date of the actual completion of the international search 01 FEBRUARY 1994	Date of mailing of the international search report MAR 17 1994
---	---

Name and mailing address of the ISA/US Commissioner of Patents and Trademarks Box PCT Washington, D.C. 20231 Facsimile No. NOT APPLICABLE	Authorized officer <i>Dinh Nguyen</i> DINH NGUYEN Telephone No. (703) 308-3255
---	--