

W. B. Stewart,
Making Wooden Boxes, &c.
N^o 6,765. Patented Oct. 2, 1849.

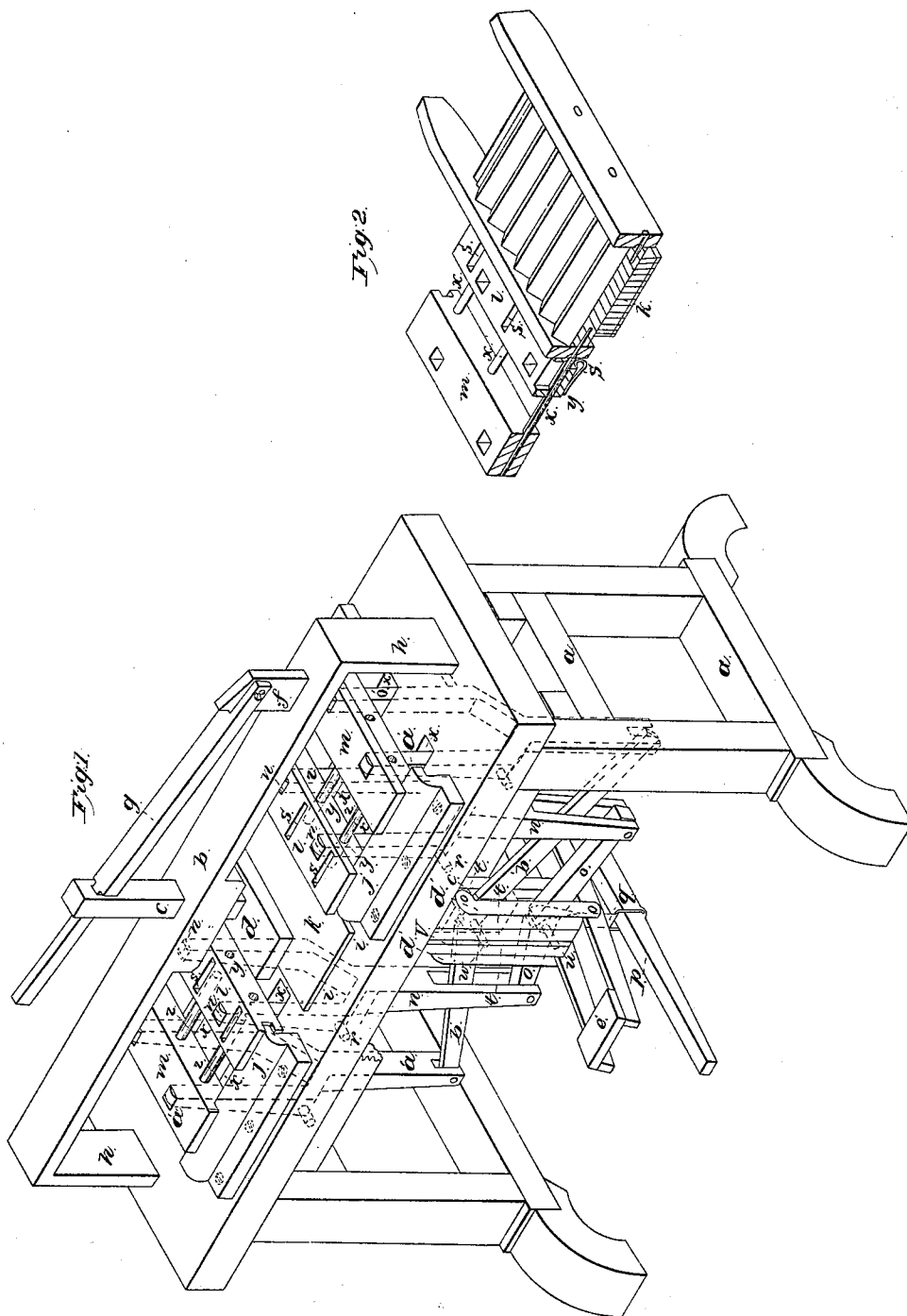

UNITED STATES PATENT OFFICE.

WILLIAM B. STEWART, OF CINCINNATI, OHIO.

MACHINE FOR MAKING WASHBOARDS.

Specification of Letters Patent No. 6,765, dated October 2, 1849.

To all whom it may concern:

Be it known that I, WILLIAM B. STEWART, of the city of Cincinnati, Hamilton county, Ohio, have invented new and useful Improvements in Machinery for Manufacturing Washboards or other Analogous Articles, and do hereby declare the following to be a full, clear, and exact description of the same, reference being had to the annexed drawings, making part of this specification, in which the machine is represented in isometrical perspective.

The necessity, which every family rich or poor, has for a good and cheap article on or with which to wash clothes, has created a demand for wash-boards such as could only be met by machinery so arranged and combined that it could supply the market. After wash-boards had undergone many changes in the construction and arrangement involved in their mechanism and had arrived at a stage of perfection scarcely admitting of being surpassed, and after the means had been invented of making the joint between the zinc and the legs of the washboard water tight by sharpening the edge of the zinc, crimping it, attaching it to the body board, and making it cut its own way into the wood of the legs by forcing the latter against the metal, the zinc and the body board being clamped down for that purpose as will be fully set forth in this specification, great delay still occurred and much loss of time was suffered in consequence of the fitting and adjustment required in making and putting the rest of the parts of a washboard together, and previous thereto nailing the legs to the body board. It was in order to obviate all further difficulties, and render the manufacture of the article sufficiently cheap for the purses of all people rich or poor that I invented the machine such as will be described.

The nature of my invention consists in nailing by pressure upon the nails when properly located and fixed for the purposes described, any one portion of any article (such as washboards, common boxes, &c.) to any other portion of the same article whether done by the precise mechanical arrangement described or done by any other analogous device. This I effect by con-

structing a suitable frame (*a*) which has a crosshead or beam (*b*) running lengthwise of the frame and intended for guiding and supporting the staff (*c*) of the clamp (*d*) and the fulcrum (*e*) on the standard (*f*) of the lever (*g*) which passes through a mortise in the staff (*c*). The beam (*b*) rests on standards (*h*) upon the table (*i*) of the frame (*a*) the incising and nailing apparatus are arranged one set on each side of the clamp (*d*) which clamp is to be adjusted and changed to suit the size of the crimp. Ways (*j*) are screwed to the table at a suitable distance (that is, at a distance a little greater than the width of the sheet of zinc when sharpened crimped and attached to the body board, and the thickness of the legs) from the bed (*k*) of the clamp. Pressure blocks slide on these ways by means of the usual arrangement of tongues and grooves—the nearest pair (*l*) to the clamp (*d*) are arranged and operated so as to precede in their action the pair (*m*) similarly arranged but farthest from the clamp. The duty in one particular of the nearest pair (*l*) is (when the crimped and edge sharpened zinc is attached to the body board of the washboard and in proper juxtaposition with the legs and pressed and held firmly down on the bed (*k*) by the clamp (*d*)) to approach one another and thereby compel the zinc to incise the legs to the required depth, by which action of the zinc the comparatively water tight joint is made between the metal and the wood. This motion is produced by means of the vertical levers (*n*) operated upon below their fulcrum by the toggle (*o*) which is attached to the treadle (*p*) by means of the metallic strap and buckle (*q*)—the levers (*n*) are suitably hung upon a fulcrum at (*v*) just above the commencement of the fork into which they divide for the purpose of equalizing their pressure along the whole bearing of the pressure blocks (*l*) against the article being manufactured. The pressure blocks (*l*) have mortises through their entire thickness as seen in the drawing for the purpose of allowing the levers (*n*) to describe the curve due to their sweep the ends of the levers (*n*) are slotted for the purpose of allowing play to another toggle to be pres-

ently described. The blocks (*l*) have mortises (*s*) with springs designed and arranged to balance the nail to be dropped therein and keep its axis horizontal as it ties in the mortise ready for use. Guides (*t*) project downward from the table (*i*) of the frame (*a*) and receive the joint pin (*u*) of the toggle (*o*) and strap (*g*) in a slot (*v*) which extends up sufficiently high to give full play to the sweep of the toggle joint pins (*u*) and (*w*) of the other toggle above alluded to. The treadle (*p*) is jointed to a standard projecting downward from the back of the frame in the usual way. The table (*i*) has suitable mortises (*x*) through which the forks of the vertical levers play—cylindrical openings (*y*) are made through the ends of the mortises (*s*). These openings give access to the drivers (*z*) to be presently described. The blocks (*l*) also act as clamps when the body board and legs are brought together for the purpose of being nailed.

The pair of blocks (*m*) farthest from the clamp (*d*) rest on the ways (*j*) by means of tongues and grooves and have the forks of the levers (*a'*) projecting up through mortises in like manner and for the same purpose at the blocks (*l*). These forked levers are arranged and operated exactly like the levers (*n*); that is, at their lower ends a toggle (*b'*) the joint pin (*w*) of which passes through a slide block (*e'*) that glides vertically between the guides (*t*) the joint pin (*w*) similarly moving in and being guided by the slot (*v*). From the block (*e'*) straps (*d'*) playing in journals, extend down to the treadle (*e'*) which is made to straddle the treadle (*p*) in order to avoid any collisions between the several parts during their motions. The blocks (*m*) have drivers (*z*) inserted horizontally through them and these drivers penetrate the mortises (*s*) through the openings (*y*) in the blocks (*l*), nails having been laid upon top of one another in the mortises (the drivers being made of suitable length for the performance of their duty, which is to press the nails home into the legs and body board thereby nailing the one to the other) and the treadle (*p*) being pressed down by the foot of the operator sufficiently far to cause the blocks (*l*) to perform their duty heretofore described; viz., to incise the legs by means of the crimped and edge sharpened zinc and attach the metal to the wood thereby and hold the wooden parts together while they are being nailed, the treadle (*e'*) is then pressed down, and through the straps (*d'*) attached to the vertical slide block (*e'*) to which the middle joint of the toggle (*b'*) is attached by the pin (*w*) and through this toggle by means of its further attachment to the lower ends of the levers (*a'*), these

levers are operated and by their forks the blocks (*m*) carrying the drivers (*z*) are made to approach each other; and the drivers carrying during each approach, a nail before them and traversing the entire breadth (and a little beyond) of the blocks (*l*) which blocks (*l*) have just performed their duty and hug closely the legs to the body board of the washboard the nail by the action of the drivers is slightly depressed below the general level of the surface of the leg, as is usual in driving and punching nails in the ordinary way.

It is obvious that the aforescribed machine can readily be made self acting by means of arms or other analogous devices, and operated by steam, water or other power. As represented, the treadles after being pressed down and made to operate the parts of the machine as above described are raised and retained by suitable straps and hooks, pendant from the ceiling of the room in which it may be. By this upraising of the treadles the pressure blocks (*l* and *m*) are withdrawn from the position they had assumed; the clamp (*d*) is then released from duty in a similar way and the washboard removed to have its back board and cap attached, and be completed by similar machinery if desired.

Having thus fully described the nature, construction and operation of my invention what I claim therein as new and desire to secure by Letters Patent is—

1. Driving by pressure and simultaneously the series of nails necessary to attach one part of a washboard, box, or other article to another part of the same as the case may be by means of the combination of machinery as described, or any equivalent device, viz. the blocks (*m*) with their series of drivers (*z*) and the block (*l*) with their series of nail boxes or mortises (*s*) springs (*s'*) and cylindrical guide openings (*y*); the blocks (*l*) forming to this extent a portion of the apparatus for nailing by pressure.

2. I claim the combination of the apparatus for driving nails by pressure as described in the foregoing specification with the clamp (*d*) and the blocks (*l*) acting as clamps on the article to be nailed by the drivers (*z*).

3. I claim the combination of machinery as described viz. the pressure blocks (*l*) in their distinct and separate capacity as such, the table (*i*) bed (*k*) and clamp (*d*) by which the crimped and edge sharpened sheet metal is made to incise the wood and by which in addition thereto the legs and body board of a washboard are put and held in suitable juxtaposition for the operation of the drivers whether the combination of machinery as described be operated by levers

toggle and treadle as described or by any equivalent devices.

4. And lastly I claim the combination of machinery viz. blocks (*m*) drivers (*z*) blocks
5 (*l*) mortises (*s*) springs (*s'*) guide openings
(*y*), ways (*j*), table (*i*), bed (*k*) and clamp
(*d*) by which I clamp, incise and clamp
and nail in the order described the several

parts of a washboard as described or a box
or other similar article, whether operated by 10
levers, toggles and treadle as described or
by other equivalent power.

WM. B. STEWART.

Attest:

EDW. H. KNIGHT,
THOS. G. CLINTON.