

(19) **DANMARK**

(10) **DK/EP 3556210 T3**



Patent- og
Varemærkestyrelsen

(12) **Oversættelse af
europæisk patentskrift**

-
- (51) Int.Cl.: **A 01 M 7/00 (2006.01)**
- (45) Oversættelsen bekendtgjort den: **2023-09-18**
- (80) Dato for Den Europæiske Patentmyndigheds bekendtgørelse om meddelelse af patentet: **2023-08-23**
- (86) Europæisk ansøgning nr.: **19401015.3**
- (86) Europæisk indleveringsdag: **2019-04-11**
- (87) Den europæiske ansøgnings publiceringsdag: **2019-10-23**
- (30) Prioritet: **2018-04-20 DE 102018109500**
- (84) Designerede stater: **AL AT BE BG CH CY CZ DE DK EE ES FI FR GB GR HR HU IE IS IT LI LT LU LV MC MK MT NL NO PL PT RO RS SE SI SK SM TR**
- (73) Patenthaver: **Amazonen-Werke H. Dreyer SE & Co. KG, Am Amazonenwerk 9-13, 49205 Hasbergen, Tyskland**
- (72) Opfinder: **Trentmann, Markus, Dörnter Weg 12, 49134 Wallenhorst, Tyskland**
- (74) Fuldmægtig i Danmark: **Novagraaf Brevets, Bâtiment O2, 2 rue Sarah Bernhardt CS90017, F-92665 Asnières-sur-Seine cedex, Frankrig**
- (54) Benævnelse: **LANDBRUGSANORDNING MED STYREENHED SAMT FREMGANGSMÅDE**
- (56) Fremdragne publikationer:
EP-A1- 2 586 304
EP-A2- 2 630 856
WO-A1-96/02817
DE-A1-102008 005 191
DE-B3-102008 009 753

AGRICULTURAL DEVICE WITH CONTROL DEVICE AND METHOD

Description

The invention relates to an agricultural machine according to the preamble of claim 1 and to a method for spreading material according to the preamble of claim 9.

5 When spreading material, such as fertilizer, pesticide or seed, on agricultural land, both the vertical guidance of a structure supporting the spreading elements of the agricultural spreader and the control of the spreading amount are of particular importance in order to be able to achieve the highest possible yield while at the same time using little material.

10 With regard to the vertical guidance, it is necessary to detect the orientation of the structure supporting the spreading elements with respect to the soil as accurately as possible in order to be able to prevent or at least reduce vertical vibrations of the structure supporting the spreading elements, for example. With regard to the control of the spreading amount, knowing the state of vitality of the plants is of particular
15 relevance so that local and needs-based material discharge can be carried out if a plant is found to be in a non-optimal state of vitality. In addition, the spreading amount can also be controlled in such a way that harmful growth, such as wild growth, is combated by spreading a suitable material.

Sensors by means of which the distance to a reference object can be determined are
20 known in the prior art. Sensors of this type are disclosed, for example, in DE 10 2008 009 753 B3, EP 2 586 304 A1 and EP 2 630 856 A2. In principle, such sensors can also be used for the vertical guidance of a structure supporting the spreading elements of an agricultural machine. Furthermore, sensors are known by means of which the reflection properties of plants can be detected, enabling plant properties
25 and/or plant states to be derived on the basis of the reflection properties.

However, fitting an agricultural machine with appropriate sensors involves a high cost, as different types of sensors have to be used for distance detection and vitality detection, as is disclosed, for example, in DE 10 2008 005 191 A1. This leads to an increase in the overall costs of corresponding agricultural machines.

In addition, very complex sensors are known from WO 96/02817 A1, which determine distances using triangulation. At the same time, reflection properties of scanned objects can be determined by comparing reflectivities of two wavelengths. These sensors are thus very complex and susceptible to the vibrations occurring in the
5 agricultural environment.

The object of the invention thus consists in enabling an agricultural machine to detect distances and plant states without substantially increasing the production costs and/or the system complexity of the agricultural machine.

This object is achieved by the characterizing features of claim 1.

10 The invention makes use of the knowledge that existing sensor types can be used for detecting a distance from a reference object and for detecting reflection properties of the reference object. The requirement to use separate sensor types for distance
15 detection and for detection of the reflective properties is thus eliminated. The reference objects for the respective sensors are preferably plants or the soil. By detecting the distance at one or more positions, the orientation and/or the distance to a structure supporting the spreading elements can be detected, enabling the structure to be vertically guided. The spreading elements can, for example, be designed as spray nozzles, wherein the structure supporting the spreading elements can, for example, be designed as a spraying boom. The one or more sensors is/are preferably
20 arranged on and/or fastened to the spraying boom. By means of the sensors, the reflection properties of plants on the soil can be detected at the same time. When spreading liquid fertilizer, liquid fertilizer can thus be selectively spread locally to plants whose reflection properties indicate a non-optimal state of health. When spreading pesticides, selective local spreading to undesired plants, such as wild
25 plants, which have been identified on the basis of their reflection properties, can be carried out.

According to the invention, the control device has an evaluation device which is connected in a signal-conducting manner to the one or more sensors and is configured to ascertain, from the sensor data from the respective sensors, the
30 distance between the respective sensors and the particular reference object and the reflection properties of the particular reference object. The evaluation device can be

configured to store the sensor data from the one or more sensors on an internal memory and/or to transmit said data to an external memory for storage. Preferably, a plurality of sensors are arranged spaced apart from one another on a support structure for the spreading elements of an agricultural machine such that the position and/or orientation of the support structure can be determined by the evaluation device using the distance values. Preferably, the plurality of sensors are spaced apart from one another in such a way that reference objects can be detected over the entire working width of the agricultural machine. This prevents individual plants to be treated from not being detected during the spreading process.

10 In a development of the control device according to the invention, the evaluation device is configured to determine the chlorophyll activity and/or the chlorophyll state of the reference object on the basis of the ascertained reflection properties. The chlorophyll state of the reference object can relate, for example, to the chlorophyll content of the reference object. The chlorophyll activity and/or the chlorophyll state of the reference object is preferably determined via one or more functions and/or via one or more calibration curves. The one or more functions and/or the one or more calibration curves preferably define a relationship between the detected reflection properties of the reference object and the chlorophyll activity and/or the chlorophyll state of the reference object.

20 According to the invention, a control device is provided in which the evaluation device is configured to determine the vitality state of the reference object on the basis of the ascertained reflection properties. Preferably, the reference object is a plant, and therefore the evaluation device is configured to detect the plant state on the basis of the ascertained reflection properties. In particular, the evaluation device is configured to determine the plant species and/or the plant type of the detected plant on the basis of the ascertained reflection properties. Preferably, the evaluation device is configured to ascertain the height or other geometric properties of the respective reference object from the sensor data from the respective sensors. The height of a reference object can be ascertained via a plurality of distance detection processes, wherein the distance from the reference object in question is compared with the distance from a reference object identified as soil. The vitality state of the reference object is preferably determined via one or more functions and/or via one or more calibration curves. The one or more functions and/or the one or more calibration curves

preferably define a relationship between the detected reflection properties and/or the detected height of the reference object and the state, in particular the vitality state, of the reference object. If the reference object is a plant, the height of the reference object relates to the plant height. Similarly to the chlorophyll content and the color of a plant, the plant height is a characteristic vitality feature from which the state of health of a plant can be derived. Furthermore, the evaluation device can be configured to determine the density of a plant population from the sensor data from the respective sensors.

According to the invention, a control device is provided in which the one or more sensors are each configured to transmit one or more electromagnetic waves and to detect the transit time and/or the intensity of the one or more electromagnetic waves reflected on the reference object. Preferably, the one or more electromagnetic waves form(s) a light beam. The distance from the reference object can be determined using the propagation delay of the one or more electromagnetic waves reflected on the reference object, taking into account the propagation speed of the electromagnetic waves. The reflection properties of the reference object can be detected using the intensity of the one or more electromagnetic waves reflected on the reference object.

In a development of the control device according to the invention, the one or more sensors comprises or each comprise one or more transmission units, in particular LED transmission units and/or laser transmission units, which are each configured to transmit a transmission signal which has a pulse and/or fluctuates in intensity.

Preferably, the plurality of transmission units are arranged next to one another such that multi-dimensional, in particular two-dimensional or three-dimensional, distance detection can be carried out by means of a plurality of individual measurements. Preferably, the one or more sensors has or each have a receiver unit configured to receive an incoming signal which has a pulse and/or an incoming signal which fluctuates in intensity. Preferably, the one or more sensors and/or the evaluation device comprises or each comprise a measuring unit which is configured to associate transmitted and received pulses and/or transmitted and received signals with one another and preferably to ascertain the propagation delay and/or the change in intensity of the one or more reflected electromagnetic waves from the time of transmission and the time of reception of associated pulses and/or signals.

In addition, a control device according to the invention in which the one or more transmitted electromagnetic waves comprise(s) light waves from the near-infrared range is advantageous. Near-infrared (NIR) is the range of the electromagnetic spectrum that is adjacent to visible light in the direction of longer wavelengths. Light waves from the near-infrared range are particularly suitable for detecting the chlorophyll state of plants.

In another embodiment of the control device according to the invention, the one or more transmitted electromagnetic waves has/have a wavelength in the range from 0.7 μm to 1.3 μm , preferably a wavelength in the range of from 780 nm to 900 nm. In particular, the evaluation device is configured to evaluate reflected electromagnetic waves from the near-infrared range, in particular having a wavelength in the range from 0.7 μm to 1.3 μm , particularly preferably having a wavelength in the range from 780 nm to 900 nm, in order to determine the reflection properties of the reference object.

The control device of the agricultural machine according to the invention is designed according to one of the embodiments described above. With regard to the advantages and modifications of the agricultural machine according to the invention, reference is initially made to the advantages and modifications of the control device according to the invention.

In a preferred embodiment of the agricultural machine according to the invention, said machine comprises a spraying boom on which a plurality of spreading elements for spreading the material formed as a spray liquid are arranged, the one or more sensors of the control device likewise being arranged on the spraying boom. The agricultural machine can be, for example, a field sprayer, in particular an add-on sprayer, a mounted sprayer, a trailed sprayer or a self-propelled sprayer. The spreading elements can be designed, for example, as spray nozzles.

In a further embodiment of the agricultural machine according to the invention, the control device is configured to use the sensor data from the one or more sensors for vertical guidance of the spraying boom and/or for vibration reduction on the spraying boom. The sensor data from the one or more sensors can be used to determine the distance from the spraying boom to the soil in several positions, enabling the

orientation of the spraying boom in relation to the soil to be ascertained. The sensor data can be used to control the inclination of the spraying boom in such a way that the spraying boom is always parallel to the soil. Furthermore, vertical vibrations can be detected on the basis of the sensor data such that the vibrations on the spraying boom can be eliminated or at least reduced by means of suitable counter-pulses.

According to the invention, an agricultural machine is provided in which the control device is configured to use the sensor data from the one or more sensors to control the spreading amount. If the evaluation device of the control device detects a plant with a non-optimal vitality state on the basis of the sensor data, local spreading of pesticide or liquid fertilizer can be carried out in the region of the detected plant by controlling the spreading amount. Furthermore, the amount of fertilizer and/or pesticide that is spread can be temporarily increased locally in order to combat undesirable plants or to help plants with a non-optimal state of health.

In another embodiment of the agricultural machine according to the invention, the control device is configured to control the spreading amount by means of pulse width modulation or pulse width frequency modulation on the spreading elements or valve units upstream of the spreading elements. Using pulse width modulation or pulse width frequency modulation, spreading amounts can be set with extreme precision without having to vary the supply pressure of the liquid to be spread. However, in addition to pulse width modulation or pulse width frequency modulation, the supply pressure of the liquid to be spread can be set at the spreading elements or the valve units upstream of the spreading elements.

Furthermore, an agricultural machine according to the invention is advantageous in which the control device is configured to use the sensor data from the one or more sensors to create an application map and/or to send said data to an external device in order to create an application map. The sensor data from the one or more sensors can also be sent to an external device for other purposes. In particular, the sensor data from the one or more sensors can be supplied to a farm management system, by means of which a farmer can manage his/her agricultural land.

The object addressed by the invention is further achieved by a method according to the characterizing features of claim 9. With regard to the advantages and

modifications of the method according to the invention, reference is initially made to the advantages and modifications of the control device according to the invention and to the advantages and modifications of the agricultural machine according to the invention.

- 5 According to the invention, the distance between the respective sensors and the relevant reference object is ascertained from the sensor data from the respective sensors, in particular by means of an evaluation device of the agricultural machine, and reflection properties of the relevant reference object are ascertained from the sensor data from the respective sensors, in particular by means of an evaluation
10 device of the agricultural machine. Alternatively or additionally, the sensor data from the one or more sensors are stored on an internal memory of the agricultural machine and/or the sensor data from the one or more sensors are transmitted to an external device.

- In addition, the method according to the invention preferably comprises ascertaining
15 the chlorophyll activity and/or the chlorophyll state of the reference object on the basis of the ascertained reflection properties and/or determining the state, in particular the vitality state, of the reference object on the basis of the ascertained reflection properties. In particular, the method comprises ascertaining the height and/or other geometric properties of the reference object from the sensor data from the respective
20 sensors. The height of the reference object can be ascertained via a plurality of distance detection processes, wherein the distance from the reference object in question is compared with the distance from a reference object identified as soil. The chlorophyll activity and/or the chlorophyll state are ascertained and/or the state, in particular the vitality state, of the reference object is determined in particular by the
25 evaluation device of the agricultural machine and/or on the basis of one or more functions and/or one or more calibration curves. If the reference object is a plant, the height of the reference object relates to the plant height. Furthermore, the method may comprise ascertaining the density of a plant population from the sensor data from the respective sensors. In addition, a method according to the invention in which the
30 one or more sensors transmits or each transmit one or more electromagnetic waves and/or the one or more sensors detect(s) the relevant propagation delay of the one or more electromagnetic waves reflected on the reference object is preferred. Alternatively or additionally, the intensity of the one or more electromagnetic waves

reflected on the reference object is detected. Furthermore, a transmission signal which has a pulse and/or fluctuates in intensity can be transmitted by the one or more transmission units, in particular LED transmission units or laser transmission units, of the respective sensors. Furthermore, a receiver unit of the one or more sensors can receive an incoming signal which has a pulse and/or fluctuates in intensity. Preferably, the plurality of transmission units are arranged next to one another such that multi-dimensional, in particular two-dimensional or three-dimensional, distance detection can be carried out by means of a plurality of individual measurements. The method preferably comprises associating the transmitted and received pulses or signals with one another. Furthermore, the method can comprise ascertaining the propagation delay of the reflected electromagnetic waves from the time of transmission and the time of reception of associated pulses or signals. Further, the method can comprise ascertaining the change in intensity of associated pulses or signals.

The method is further advantageously developed in that the one or more transmitted electromagnetic waves comprise(s) wavelengths from the near-infrared range. The one or more transmitted electromagnetic waves preferably has or have a wavelength in the range from 700 nm to 1.3 μm , in particular a wavelength in the range from 780 nm to 900 nm.

Furthermore, a method according to the invention is preferred in which the agricultural machine has a spraying boom on which a plurality of spreading elements for spreading the material formed as a spray liquid are arranged, and the one or more sensors is/are arranged on the spraying boom. In particular, the method comprises performing vertical guidance on the spraying boom on the basis of the sensor data from the one or more sensors and/or performing vibration reduction on the spraying boom on the basis of the sensor data from the one or more sensors. According to the invention, the method comprises controlling the spreading amount on the basis of the sensor data from the one or more sensors. Alternatively or additionally, the method according to the invention comprises creating an application map on the basis of the sensor data from the one or more sensors by means of the agricultural machine and/or an external device. The agricultural machine can be a field sprayer, in particular an add-on sprayer, a built-on sprayer, a trailed sprayer or a self-propelled sprayer. The spreading amount is preferably controlled by means of pulse width modulation or pulse width frequency modulation on the spreading elements or valve

units upstream of the spreading elements. The method may comprise transmitting the sensor data from the one or more sensors to an external device.

Further details of the invention can be found in the description of the figures and in the drawings. The following are shown:

5 Fig. 1 a perspective view of an embodiment of the agricultural machine according to the invention;

Fig. 2 a schematic view of an embodiment of the control device according to the invention;

10 Fig. 3 a rear view of an embodiment of the agricultural machine according to the invention; and

Fig. 4 an evaluation of electromagnetic waves according to the method according to the invention.

Fig. 1 shows an agricultural machine 100 designed as a trailed sprayer, by means of which fertilizer, namely liquid fertilizer, and liquid pesticide can be spread. The
15 agricultural machine 100 is drawn by a towing vehicle 200 in the form of a tractor.

In addition to a storage tank 110, the agricultural machine 100 has a spraying boom 102 comprising a left arm 104a and a right arm 104b. The spraying boom 102 is divided into boom sections 106a-106i, wherein adjacent boom sections 106a-106i of an arm 104a, 104b can be pivoted relative to one another.

20 A plurality of spreading elements 108 designed as spray nozzles are arranged on the spraying boom 102 for spreading a material formed as a spray liquid.

The agricultural machine 100 also has a control device 10 for controlling the spreading process. The control device 10 comprises a plurality of sensors 12, 12a-12f (not shown in Fig. 1) and an evaluation device 14. The sensors 12, 12a-12f are
25 arranged on the spraying boom 104 over the entire working width of the agricultural machine 100 and are each configured to supply sensor data for detecting a distance from a reference object B1, B2 and for detecting reflection properties of the reference object B1, B2. The evaluation device 14 is configured to determine the distance

between the respective sensors 12, 12a-12f and the particular reference object B1, B2 and the reflection properties of the particular reference object B1, B2 from the sensor data from the respective sensors 12, 12a-12f. The reference objects B1, B2 for the respective sensors 12, 12a-12f can be, for example, plants or the soil.

- 5 Furthermore, the height of a reference object B1 identified as a plant can be ascertained from the sensor data from the respective sensors 12, 12a-12f.

Fig. 2 shows a corresponding control device 10 having a sensor 12 which is connected in a signal-conducting manner to an evaluation device 14. The sensor 12 is configured to transmit electromagnetic waves 18 and to detect the propagation delay 32 and the intensity of the electromagnetic waves 24 reflected on the reference object B1 formed as a plant. For this purpose, the sensor 12 has a transmission unit 16, namely an LED transmission unit, which is configured to transmit a transmission signal which has a pulse 20. In addition, the sensor 12 comprises a receiver unit 22 configured to receive an incoming signal which has a pulse 26. The sensor 12 or the
10 evaluation device 14 further comprises a measuring unit which is configured to associate the transmitted and received pulse 20, 26 with one another and to detect the change in pulse as well as to ascertain the propagation delay 32 of the reflected electromagnetic waves 18, 24 from the time of transmission 28 and the time of reception 30 of these pulses 20, 26. The transmitted electromagnetic waves 18
15 comprise light waves from the near-infrared range having a wavelength in the range from 0.7 μm to 1.3 μm . Accordingly, the evaluation device 14 is configured to evaluate reflected electromagnetic waves 24 having a wavelength in the range from 0.7 μm to 1.3 μm in order to ascertain the reflection properties of the reference object B1.

The evaluation device 14 is configured to ascertain the chlorophyll state of the
25 reference object B1 formed as a plant and to determine the vitality state of the reference object B1 formed as a plant on the basis of the ascertained reflection properties using functions and/or calibration curves. When determining the vitality state of the reference object B1 formed as a plant, the previously ascertained plant height is also taken into account.

- 30 Furthermore, the evaluation device 14 is configured to store the sensor data from the sensor 12 on an internal memory and to transmit said data to an external device for further evaluation.

It is not illustrated that the sensor 12 can also comprise a plurality of transmission units 16 arranged next to one another, enabling two-dimensional distance measurement to be carried out using a plurality of individual measurements. In this case, electromagnetic waves are transmitted in different directions from the individual transmission units 16 of the sensor 12.

Fig. 3 shows an agricultural machine 100 designed as a field sprayer and comprising a control device 10. The control device 10 comprises a plurality of sensors 12a-12f and an evaluation device 14 connected in a signal-conducting manner to the sensors 12a-12f. The sensors 12a-12f are arranged on a spraying boom 102 and are each configured to provide sensor data for detecting reflection properties of reference objects B1 designed as plants and for detecting the distance from the reference object B2 formed as soil.

The control device 10 is configured to use the sensor data from the sensors 12a-12f for vertical guidance of the spraying boom 102, for vibration reduction on the spraying boom 102 and for controlling the spreading amount. The spreading amount is controlled by means of pulse width frequency modulation on the spreading elements 108, which are designed as spray nozzles.

The sensor data from the sensors 12a-12f are also used to create an application map. For this purpose, the sensor data from the sensors 12a-12f are transmitted to an external device in order to create the application map.

Fig. 4 shows the manner in which the distance between a sensor 12 and a reference object B1, B2 and the reflection properties of the reference object B1, B2 can be ascertained from the sensor data from the sensor 12.

First, electromagnetic waves 18 are transmitted by the sensor 12. The transmitted signal is then reflected by reference object B1, B2. The propagation delay 32 and the intensity of the electromagnetic waves 24 reflected on the reference object B1, B2 can then be detected by means of the sensor 12.

For this purpose, the transmitted signal 18 comprises a pulse 20. Accordingly, the received signal 24 also has a pulse 26. The transmitted and received pulses 20, 26 can be associated with one another such that the propagation delay 32 can be

ascertained from the time of transmission 28 and the time of reception 30 of associated pulses 20, 26. In this manner, the distance from the reference object B1, B2 can be ascertained by means of the propagation speed of electromagnetic waves. In addition, the reflection properties of the reference object B1, B2 can be determined
5 by comparing the transmitted and received pulses 20, 26, in particular their intensity.

The chlorophyll activity and/or the vitality state of the reference object B1, B2 can then be ascertained on the basis of the ascertained reflection properties.

List of reference signs

	10	Control device
	12, 12a-12f	Sensors
	14	Evaluation device
5	16	Transmission unit
	18	Electromagnetic wave
	20	Pulse
	22	Receiver unit
	24	Electromagnetic wave
10	26	Pulse
	28	Time of transmission
	30	Time of reception
	32	Propagation delay
	100	Agricultural machine
15	102	Spray boom
	104a, 104b	Lateral arms
	106a-106i	Boom portions
	108	Spreading elements
	110	Supply tank

200 Towing vehicle

B1, B2 Reference objects

PATENTKRAV

1. Landbrugsmaskine (100) til spredning af materiale, f.eks. gødning, plantebeskyttelsesmiddel eller frø, hvilken landbrugsmaskine omfatter en styreenhed (10) til styring af spredeprocessen, hvilken styreenhed (10) er
5 udformet til at have

- én eller flere sensorer (12, 12a-12f), som hver især er konfigureret til at tilvejebringe sensordata til detektering af en afstand fra et referenceobjekt (B1, B2),

hvor den ene eller flere sensorer (12, 12a-12f) hver især er konfigureret til at tilvejebringe sensordata til detektering af refleksionsegenskaber for
10 referenceobjektet (B1, B2), hvor den ene eller flere sensorer (12, 12a-12f) hver især er konfigureret til at udsende én eller flere elektromagnetiske bølger (18) og til at detektere løbetiden (32) for og intensiteten af den ene eller flere elektromagnetiske bølger (24) reflekteret på referenceobjektet (B1, B2),

kendetegnet ved en evalueringsindretning (14), som er forbundet til den
15 ene eller flere sensorer (12, 12a-12f) på en signalledende måde og er konfigureret til at konstatere, på grundlag af sensordataene fra de respektive sensorer (12, 12a-12f), de respektive sensorers (12, 12a-12f) afstand fra det pågældende referenceobjekt (B1, B2) og det pågældende referenceobjekts (B1, B2) refleksionsegenskaber, hvor afstanden fra referenceobjektet bestemmes via
20 løbetiden for den ene eller flere elektromagnetiske bølger reflekteret på referenceobjektet, under hensyntagen til de elektromagnetiske bølgers udbredelseshastighed, og hvor referenceobjektets refleksionsegenskaber detekteres via intensiteten af den ene eller flere elektromagnetiske bølger reflekteret på referenceobjektet, hvor evalueringsindretningen (14) er konfigureret
25 til at bestemme referenceobjektets (B1, B2) vitalitetstilstand på grundlag af de konstaterede refleksionsegenskaber, hvor den ene eller flere sensorers sensordata anvendes til at styre spredemængden, hvor mængden øges lokalt, når der detekteres en plante med en ikke-optimal vitalitetstilstand.

2. Styreenhed (10) ifølge krav 1,

kendetegnet ved, at evalueringsindretningen (14) er konfigureret til at bestemme referenceobjektets (B1, B2) klorofylaktivitet og/eller klorofyltilstand på grundlag af de konstaterede refleksionsegenskaber.

3. Styreenhed (10) ifølge et hvilket som helst af de foregående krav,

5 **kendetegnet ved, at** den ene eller flere sensorer (12, 12a-12f) hver især omfatter én eller flere sendeenheder (16), især LED-baserede sendeenheder og/eller laserbaserede sendeenheder, som hver især er konfigureret til at sende et transmissionssignal, som har en puls (20) og/eller varierer i intensitet.

4. Styreenhed (10) ifølge et hvilket som helst af de foregående krav,

10 **kendetegnet ved, at** den ene eller flere udsendte elektromagnetiske bølger (18) omfatter lysbølger fra det nær-infrarøde spektrum.

5. Landbrugsmaskine (100) ifølge et hvilket som helst af de foregående krav,

15 **kendetegnet ved** en sprøjtebom (102), hvorpå et antal spredeelementer (108) til spredning af materialet, der udgøres af en sprøjtevæske, er anbragt, hvor styreenhedens (10) ene eller flere sensorer (12, 12a-12f) ligeledes er anbragt på sprøjtebommen (102).

6. Landbrugsmaskine (100) ifølge krav 5,

20 **kendetegnet ved, at** styreenheden (10) er konfigureret til at anvende sensordataene fra den ene eller flere sensorer (12, 12a-12f) til vertikal styring af sprøjtebommen (102) og/eller til vibrationsreduktion på sprøjtebommen (102).

7. Landbrugsmaskine (100) ifølge et hvilket som helst af de foregående krav,

25 **kendetegnet ved, at** styreenheden (10) er konfigureret til at styre spredemængden ved hjælp af pulsbreddemodulation eller pulsbreddefrekvensmodulation på spredeelementerne (108) eller ventilhuse opstrøms for spredeelementerne (108).

8. Landbrugsmaskine (100) ifølge et hvilket som helst af de foregående krav,

kendetegnet ved, at styreenheden (10) er konfigureret til at anvende sensordataene fra den ene eller flere sensorer (12, 12a-12f) til at udarbejde et tildelingskort og/eller til at sende dataene til en ekstern anordning for at udarbejde et tildelingskort.

5 9. Fremgangsmåde til spredning af materiale, f.eks. gødning, plantebeskyttelsesmiddel eller frø, hvilken fremgangsmåde fortrinsvis udføres ved hjælp af en landbrugsmaskine (100) ifølge et hvilket som helst af krav 8 til 12, hvilken fremgangsmåde omfatter følgende trin:

- 10 - udsendelse af én eller flere elektromagnetiske bølger (18) ved hjælp af én eller flere sensorer (12, 12a-12f),
- generering af sensordata, hvor en landbrugsmaskines (100) ene eller flere sensorer (12, 12a-12f) anvendes til at detektere en afstand for de respektive sensorer (12, 12a-12f) fra et referenceobjekt (B1, B2),
- 15 - generering af sensordata, hvor den ene eller flere sensorer (12, 12a-12f) anvendes til at detektere referenceobjektets (B1, B2) refleksionsegenskaber,
- detektering af den pågældende løbetid (32) for den ene eller flere elektromagnetiske bølger (24) reflekteret på referenceobjektet (B1, B2) ved hjælp af den ene eller flere sensorer (12, 12a-12f),
- 20 - detektering af intensiteten af den ene eller flere elektromagnetiske bølger (24) reflekteret på referenceobjektet (B1, B2),

kendetegnet ved følgende trin:

- 25 - konstatering af de respektive sensorers (12, 12a-12f) afstand fra det pågældende referenceobjekt (B1, B2) på grundlag af sensordataene fra de respektive sensorer (12, 12a-12f) vedrørende løbetiden for den ene eller flere elektromagnetiske bølger reflekteret på referenceobjektet, under hensyntagen til de elektromagnetiske bølgers udbredelseshastighed, især ved hjælp af en evalueringsindretning (14) på landbrugsmaskinen (100);

- konstatering af det pågældende referenceobjekts (B1, B2) refleksionsegenskaber på grundlag af de respektive sensorers (12, 12a-12f) sensordata via intensiteten af den ene eller flere elektromagnetiske bølger reflekteret på referenceobjektet, især ved hjælp af en evalueringsindretning (14) på landbrugsmaskinen (100);
- bestemmelse af referenceobjektets (B1, B2) vitalitetstilstand på grundlag af de konstaterede refleksionsegenskaber,
- styring af spredemængden på grundlag af sensordataene fra den ene eller flere sensorer (12, 12a-12f); hvor mængden øges lokalt, når der detekteres en plante med en ikke-optimal vitalitetstilstand.

10. Fremgangsmåde ifølge krav 9,

kendetegnet ved mindst ét af følgende trin:

- lagring af sensordataene fra den ene eller flere sensorer (12, 12a-12f) i en intern hukommelse i landbrugsmaskinen (100);
- transmission af sensordataene fra den ene eller flere sensorer (12, 12a-12f) til en ekstern anordning.

11. Fremgangsmåde ifølge krav 10,

kendetegnet ved mindst ét af følgende trin:

- konstatering af referenceobjektets (B1, b2) klorofylaktivitet og/eller klorofyltilstand på grundlag af de konstaterede refleksionsegenskaber,
- bestemmelse af referenceobjektets (B1, B2) tilstand, især vitalitetstilstand, på grundlag af de konstaterede refleksionsegenskaber.

12. Fremgangsmåde ifølge et hvilket som helst af krav 9 til 11,

kendetegnet ved mindst ét af følgende trin:

- udsendelse af et transmissionssignal, der har en puls (20) og/eller varierer i intensitet, ved hjælp af én eller flere sendeenheder (16), især LED-baserede

sendeenheder eller laserbaserede sendeenheder, i de respektive sensorer (12, 12a-12f);

- modtagelse af et modtaget signal, som har en puls (26) og/eller varierer i intensitet, ved hjælp af en modtageenhed (22) i den ene eller flere sensorer (12, 5 12a-12f).

13. Fremgangsmåde ifølge et hvilket som helst af krav 9 til 12,

kendetegnet ved, at den ene eller flere udsendte elektromagnetiske bølger (18) omfatter bølgelængder fra det nær-infrarøde spektrum.

14. Fremgangsmåde ifølge et hvilket som helst af krav 9 til 13,

- 10 hvor landbrugsmaskinen (100) har en sprøjtebom (102), hvorpå et antal spredeelementer (108) til spredning af materialet, der udgøres af en sprøjtevæske, er anbragt, og hvor den ene eller flere sensorer (12, 12a-12f) er anbragt på sprøjtebommen (102),

kendetegnet ved mindst ét af følgende trin:

- 15 - udførelse af vertikal styring på sprøjtebommen (102) på grundlag af sensordataene fra den ene eller flere sensorer (12, 12a-12f);
- udførelse af vibrationsreduktion på sprøjtebommen (102) på grundlag af sensordataene fra den ene eller flere sensorer (12, 12a-12f);
 - udarbejdelse af et tildelingskort på grundlag af sensordataene fra den ene 20 eller flere sensorer (12, 12a-12f), ved hjælp af landbrugsmaskinen (100) og/eller en ekstern anordning.

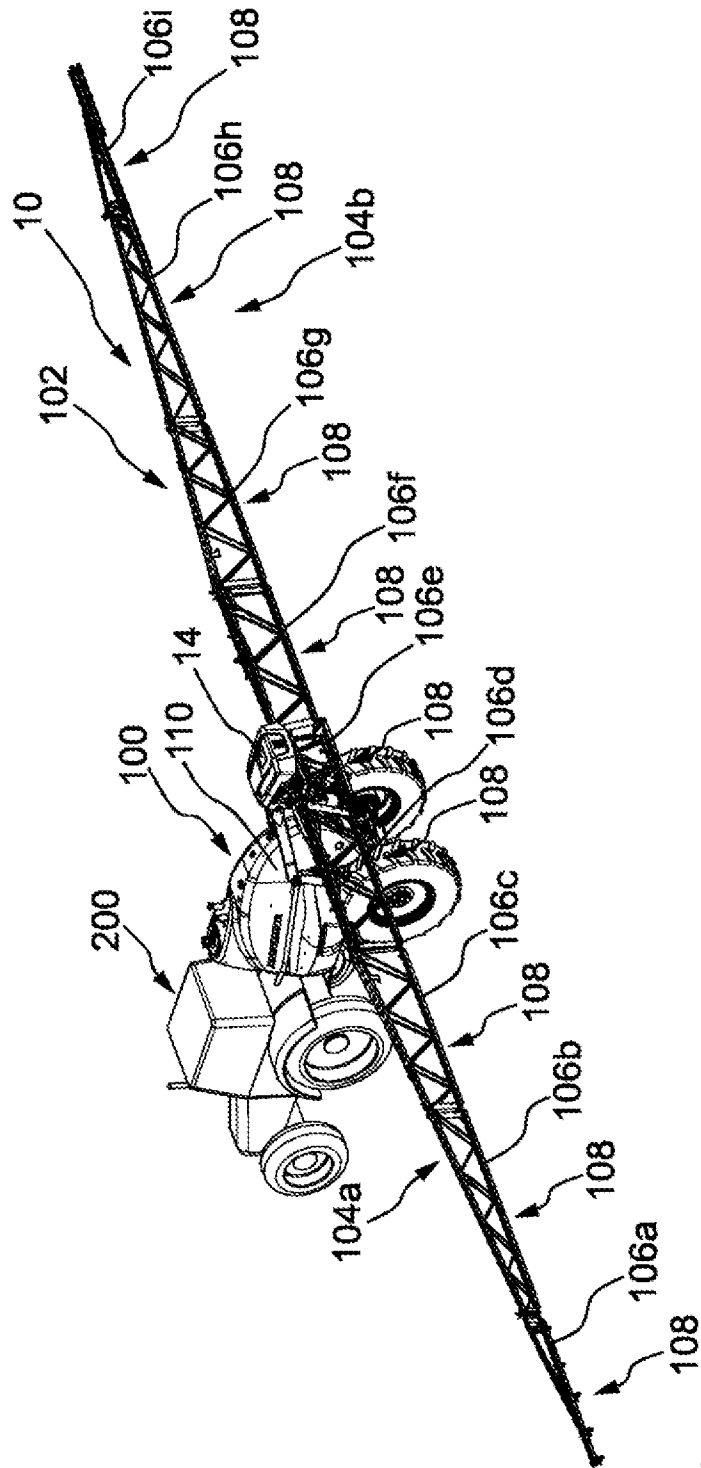

Fig.1

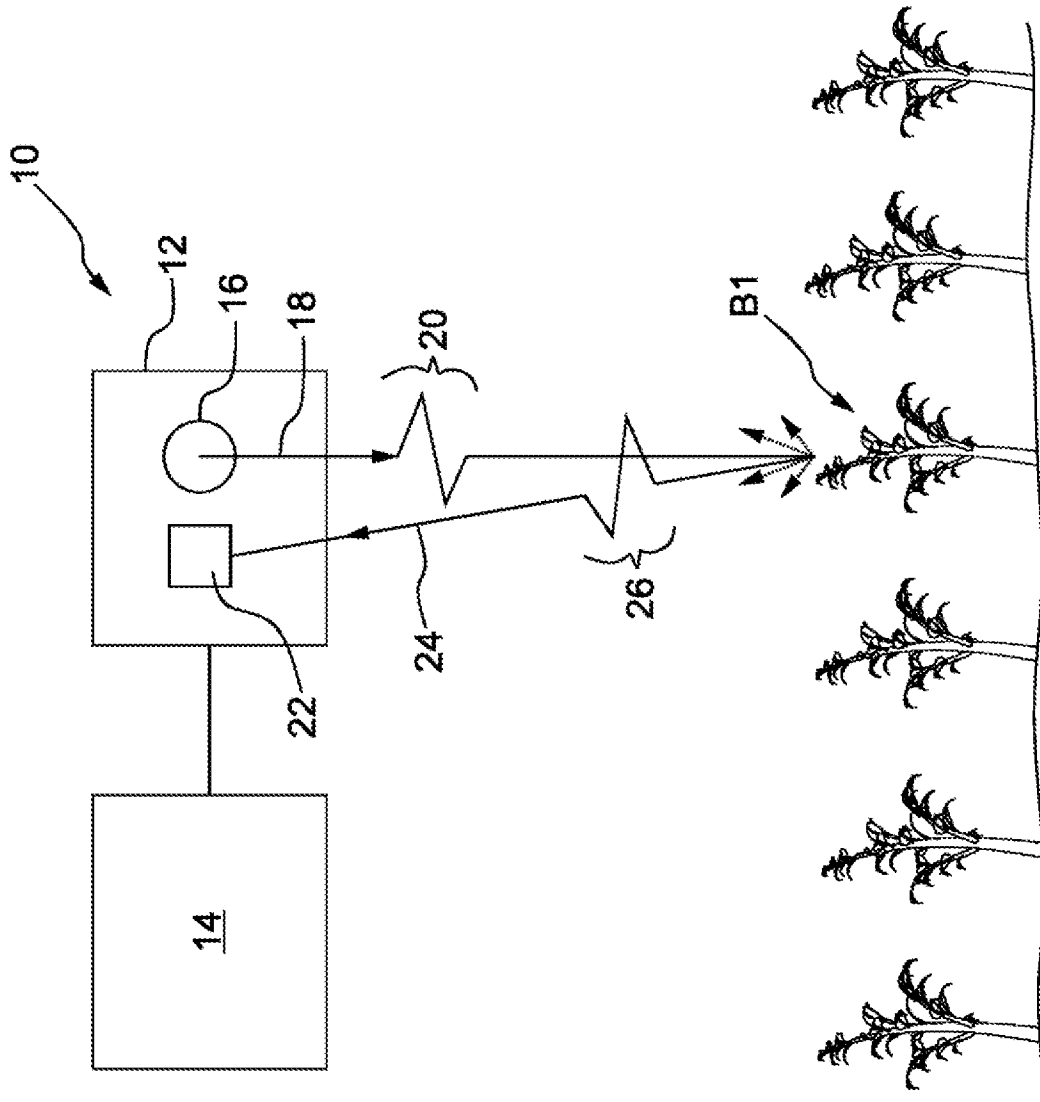

Fig.2

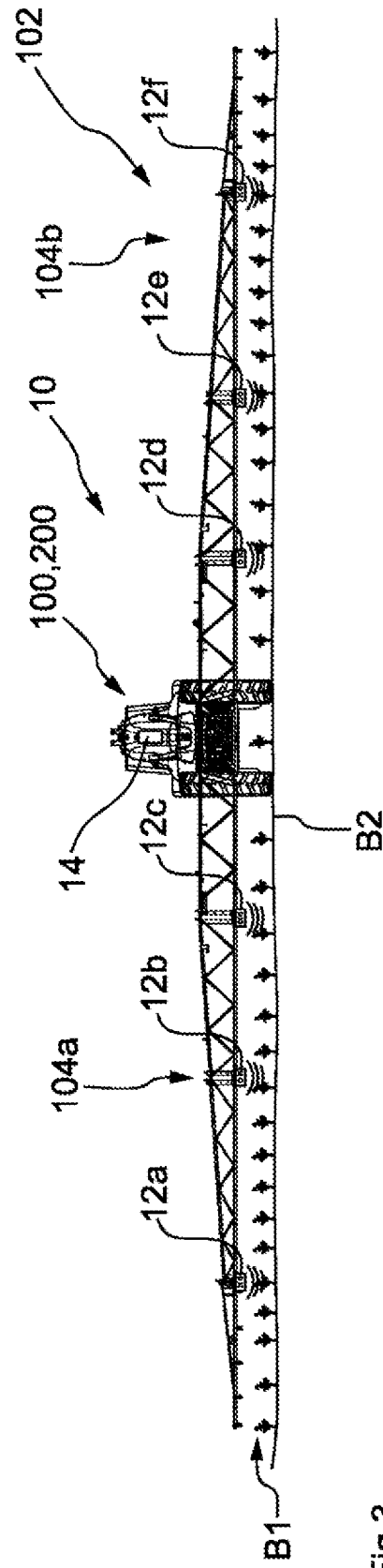

Fig.3

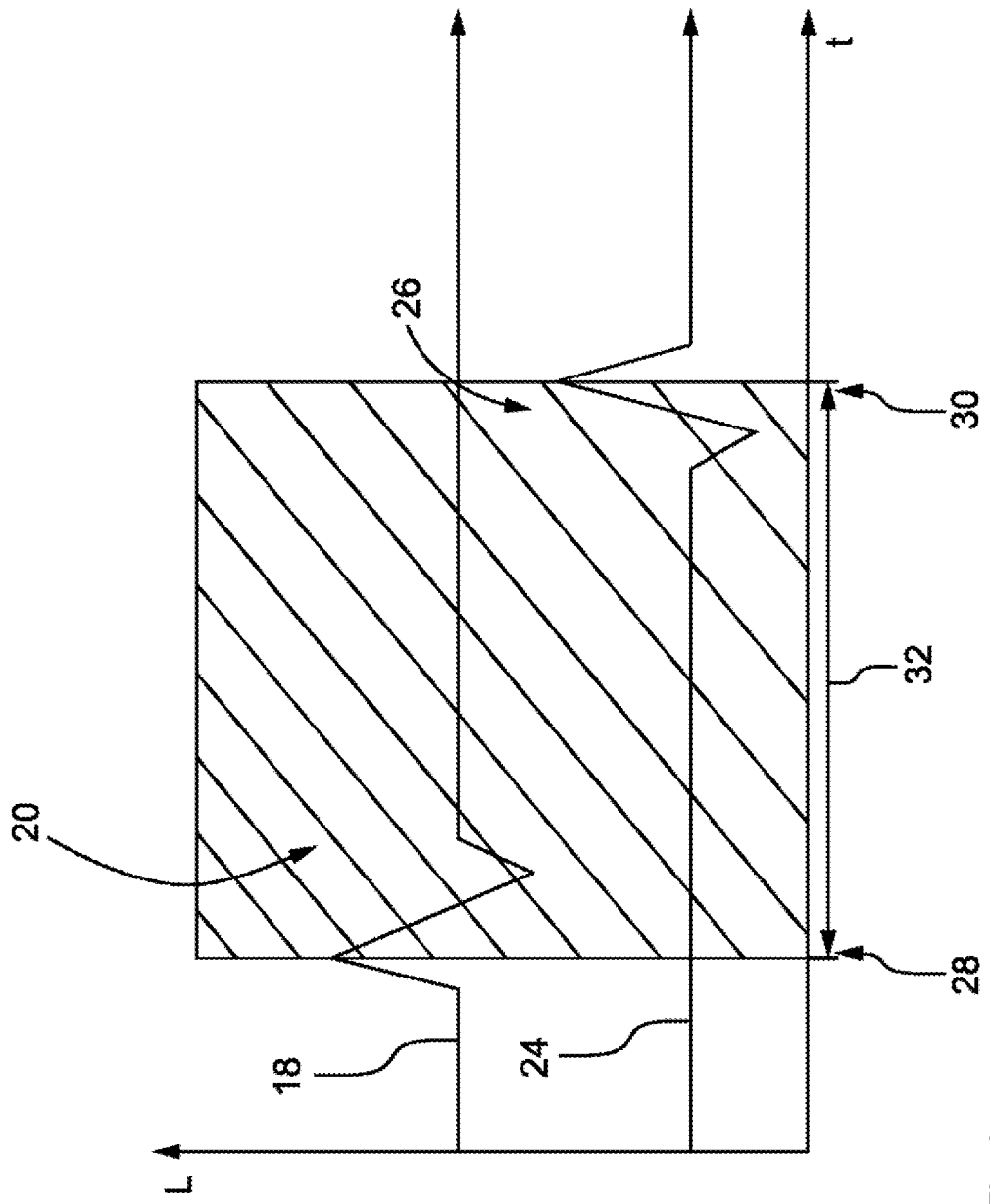

Fig.4