



- (51) International Patent Classification:
F24F 6/00 (2006.01) F24F 13/20 (2006.01)
- (21) International Application Number:
PCT/KR2012/011545
- (22) International Filing Date:
27 December 2012 (27.12.2012)
- (25) Filing Language: English
- (26) Publication Language: English
- (30) Priority Data:
10-2012-0021039
29 February 2012 (29.02.2012) KR
10-2012-0142216 7 December 2012 (07.12.2012) KR
- (71) Applicant: COWAY CO., LTD. [KR/KR]; 136-23, Yugumagoksa-ro, Yugu-eup, Gongju-si, Chungcheongnam-do 314-895 (KR).
- (72) Inventors: BAE, Jun-Hyoung; R&D Center Seoul National University Research Park, 60, Nakseong-daero15-gil, Gwanak-gu, Seoul, 151-851 (KR). LEE, Kyung-Mi; R&D Center Seoul National University Research Park, 60, Nakseong-daero15-gil, Gwanak-gu, Seoul, 151-851 (KR). LEE, Chan-Yong; R&D Center Seoul National University Research Park, 60, Nakseong-daero15-gil, Gwanak-gu, Seoul, 151-851 (KR).

(74) Agent: C&S PATENT AND LAW OFFICE; 7th Floor, Daelim Acrotel, 13, Eonju-ro 30-gil, Gangnam-gu, Seoul 135-971 (KR).

(81) Designated States (unless otherwise indicated, for every kind of national protection available): AE, AG, AL, AM, AO, AT, AU, AZ, BA, BB, BG, BH, BN, BR, BW, BY, BZ, CA, CH, CL, CN, CO, CR, CU, CZ, DE, DK, DM, DO, DZ, EC, EE, EG, ES, FI, GB, GD, GE, GH, GM, GT, HN, HR, HU, ID, IL, IN, IS, JP, KE, KG, KM, KN, KP, KZ, LA, LC, LK, LR, LS, LT, LU, LY, MA, MD, ME, MG, MK, MN, MW, MX, MY, MZ, NA, NG, NI, NO, NZ, OM, PA, PE, PG, PH, PL, PT, QA, RO, RS, RU, RW, SC, SD, SE, SG, SK, SL, SM, ST, SV, SY, TH, TJ, TM, TN, TR, TT, TZ, UA, UG, US, UZ, VC, VN, ZA, ZM, ZW.

(84) Designated States (unless otherwise indicated, for every kind of regional protection available): ARIPO (BW, GH, GM, KE, LR, LS, MW, MZ, NA, RW, SD, SL, SZ, TZ, UG, ZM, ZW), Eurasian (AM, AZ, BY, KG, KZ, RU, TJ, TM), European (AL, AT, BE, BG, CH, CY, CZ, DE, DK, EE, ES, FI, FR, GB, GR, HR, HU, IE, IS, IT, LT, LU, LV, MC, MK, MT, NL, NO, PL, PT, RO, RS, SE, SI, SK, SM, TR), OAPI (BF, BJ, CF, CG, CI, CM, GA, GN, GQ, GW, ML, MR, NE, SN, TD, TG).

Published:
— with international search report (Art. 21(3))

(54) Title: WATER LEAKAGE PREVENTING HUMIDIFICATION APPARATUS

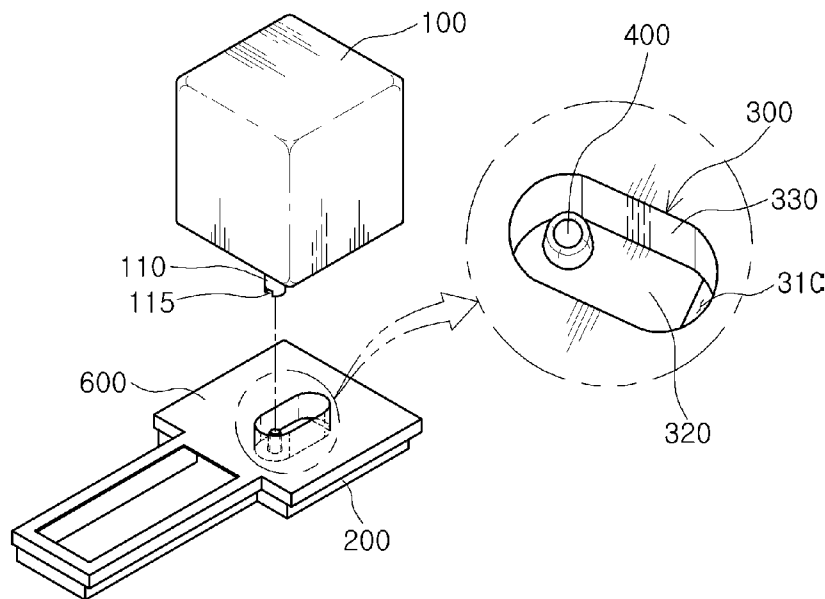

(57) Abstract: There is provided a water leakage preventing humidification apparatus including: a housing; a water tank installed in the housing and storing water for humidification; a water bottle having a water guide unit having an outlet formed therein to allow water to flow out therefrom, and installed in the water tank to provide water for humidification to the water tank; an installation part disposed in the water tank and having a confinement water formed to surround at least a portion of the circumference of the water guide unit of the water bottle and a water tank input hole formed on one end of the bottom surface along which water flowing out through the outlet flows and communicating with the water tank; and a humidification unit provided to perform humidification with water stored in the water tank.

WO 2013/129764 A1

Description

Title of Invention: WATER LEAKAGE PREVENTING HUMIDIFICATION APPARATUS

Technical Field

- [1] The present invention relates to a water leakage preventing humidification apparatus for preventing water leakage and, more particularly, to a water leakage preventing humidification apparatus capable of preventing water from leaking when the humidification apparatus is sloped.

Background Art

- [2] In general, a humidification apparatus is an apparatus artificially generating and releasing moisture to increase humidity of an indoor area.
- [3] Humidification apparatuses may be classified into various types thereof, according to a method of generating moisture used therein.
- [4] First, a heating type humidification apparatus naturally releases steam generated by heating water stored in a water tank within an indoor area. A supersonic humidification apparatus releases water particles vaporized by ultrasonically-vibrating water stored in a water tank.
- [5] Also, a compound humidification apparatus including both a heating type humidification scheme and an ultrasonic humidification scheme has been used.
- [6] Recently, a natural (a ventilation type) humidification apparatus in which a humidification filter is immersed in a water tank and water moving upwardly of the humidification filter is vaporized by an air blast or in which some of a plurality of disks are immersed in a water tank and rotated to allow water remaining to surfaces of the disks to be vaporized has also been used.
- [7] Meanwhile, referring to FIG. 1, in a related art humidification apparatus, in a state in which a water tank 40 and a water bottle 50 are coupled, a valve 30 of an opening and closing unit 20 provided in the water bottle 50 is pressurized by a protrusion 10 so as to be opened.
- [8] Thereafter, when a water surface of the water tank 40 is consistent with a lower end of the opening and closing unit 20, air cannot be introduced and water stored in the water bottle 50 may no longer be discharged to the outside.
- [9] However, when the humidification apparatus is sloped due to a movement thereof, or the like, water accommodated in the water tank 50 may be moved to one side therein, so that water accommodated in the water tank 40 and water stored in the water bottle 50 are separated, generating space in the separated spot to allow air to be introduced thereto.

[10] Here, since air is introduced to the interior of the water bottle 50 through the opening and closing unit 20 opened in a state of being coupled to the protrusion 10, water within the water bottle 50 is discharged to the outside according to the introduction of air.

[11] As a result, when the related art humidification apparatus is sloped due to a movement thereof, or the like, water continuously flows out of the water bottle 50 to overflow to the outside.

Disclosure of Invention

Technical Problem

[12] An aspect of the present invention provides a water leakage preventing humidification apparatus capable of preventing water from leaking even in the case that the humidification apparatus is sloped.

Solution to Problem

[13] According to an aspect of the present invention, there is provided a water leakage preventing humidification apparatus, including: a housing; a water tank installed in the housing and storing water for humidification; a water bottle having a water guide unit having an outlet formed therein to allow water to flow out therefrom, and installed in the water tank to provide water for humidification to the water tank; an installation part disposed in the water tank and having a confinement wall formed to surround at least a portion of the circumference of the water guide unit of the water bottle and a water tank input hole formed on one end of the bottom surface along which water flowing out through the outlet flows and communicating with the water tank; and a humidification unit provided to perform humidification with water stored in the water tank, wherein when the housing is sloped at a predetermined angle or more, a water confinement space is formed between the confinement wall and the water tank input hole of the installation part to confine water therein.

[14] In an embodiment, the bottom surface of the installation part may extend in a length direction of the water tank.

[15] Here, the outlet may be positioned in a front surface of the bottom surface of the installation part, and the water tank input hole may be positioned in a rear surface of the bottom surface of the installation part.

[16] Also, the installation part may be disposed in a rear portion of the water tank.

[17] Also, in an embodiment, the outlet may be open in a position opposite to the water tank input hole.

[18] Meanwhile, the confinement wall of the installation part may be formed to extend upwardly from the edge of the bottom surface of the installation part such that it is higher than the outlet, when the water bottle is installed in the installation part.

- [19] Also, the humidification apparatus may further include: a protrusion formed in the installation part and pressurizing the opening and closing unit formed on the water bottle to open the opening and closing unit, when the water guide unit is installed in the installation part.
- [20] The protrusion may be protruded from the bottom surface of the installation part.
- [21] Meanwhile, in another embodiment, the bottom surface of the installation part may be formed to be sloped downwardly toward the water tank input hole.
- [22] Also, the humidification apparatus may further include: a water tank cover coupled to an upper end of the water tank, wherein the installation part may be formed in the water tank cover.
- [23] In a water leakage preventing humidification apparatus according to another embodiment of the present invention, the installation part may be protruded from the bottom of the water tank.
- [24] Meanwhile, the housing may further include an air purifying filter installed therein.

Advantageous Effects of Invention

- [25] In the case of the water leakage preventing humidification apparatus according to embodiment of the present invention, although the water leakage preventing humidification apparatus is sloped, water trapped in a settling region blocks an outlet of the water bottle, thus preventing water from leaking from the water bottle.
- [26] Also, in the case of the water leakage preventing humidification apparatus according to embodiment of the present invention, when the water leakage preventing humidification apparatus is sloped, since an outlet is positioned to be lower than a water level and a water tank input hole is positioned to be higher than the water level, thus preventing water from leaking from the water bottle.

Brief Description of Drawings

- [27] FIG. 1 is a perspective view of a related art humidification apparatus.
- [28] FIG. 2 is an exploded perspective view of a water leakage preventing humidification apparatus according to an embodiment of the present invention.
- [29] FIG. 3 is an exploded perspective view of a water bottle and a water tank of the water leakage preventing humidification apparatus according to an embodiment of the present invention.
- [30] FIG. 4 is a cross-sectional view illustrating the water leakage preventing humidification apparatus maintained horizontally according to an embodiment of the present invention.
- [31] FIGS. 5 and 6 are cross-sectional views illustrating sloped water leakage preventing humidification apparatuses according to an embodiment of the present invention.
- [32] FIG. 7 is a perspective view illustrating an interior of a water guide unit of the water

leakage preventing humidification apparatus according to an embodiment of the present invention.

[33] FIG. 8 is a cross-sectional view illustrating the water leakage preventing humidification apparatus maintained horizontally according to another embodiment of the present invention.

[34] FIG. 9 is a cross-sectional view illustrating a sloped water leakage preventing humidification apparatus according to another embodiment of the present invention.

[35] FIG. 10 is a view illustrating a water tank and a settling region of the water leakage preventing humidification apparatus according to another embodiment of the present invention.

[36] FIG. 11 is a cross-sectional view illustrating an installation structure of the water bottle with respect to the water tank of the water leakage preventing humidification apparatus according to another embodiment of the present invention.

Best Mode for Carrying out the Invention

[37] In the present disclosure, singular forms "a", "an" and "the" are intended to include the plural forms as well, unless the context clearly indicates otherwise. It will be further understood that terms such as "including" or "having," etc., are intended to indicate the existence of the features, numbers, operations, actions, components, parts, or combinations thereof disclosed in the specification, and are not intended to preclude the possibility that one or more other features, numbers, operations, actions, components, parts, or combinations thereof may exist or may be added.

[38] Hereinafter, a humidification apparatus 1000 will be described in detail with reference to the accompanying drawings.

[39] Referring to FIG. 2, the humidification apparatus 1000 according to an embodiment of the present invention includes a housing 900, a water bottle 100, and a water tank 200.

[40] The housing 900 forms an outer appearance of the humidification apparatus 1000 according to an embodiment of the present invention.

[41] The water bottle 100 may be installed in the water tank 200 and provide water for humidification to the water tank 200.

[42] The water tank 200 may be insertedly installed in the housing 300 and store water for humidification to provide stored humidification water to a humidification unit 700.

[43] Hereinafter, respective components will be described in detail.

[44] Referring to FIG. 2, the water bottle 100 includes a water guide unit 110 having an outlet 115 allowing water to be discharged therethrough, in order to provide water used for humidification.

[45] In an embodiment, the water guide unit 110 may extend from a lower portion of the

water bottle 100 in a length direction.

[46] The water guide unit 110 may have a hollow structure to guide a movement of water when water stored in the water bottle 100 is introduced to the water tank 200.

[47] Also, referring to FIGS. 4 and 7, an opening and closing unit 500 for opening and closing the water bottle 100 may be provided within the water guide unit 110

[48] Here, the opening and closing unit 500 may include a sealing unit 510 opening and closing the water guide unit 110 to allow water to flow out therefrom or flow in therethrough, and a rod unit 520 connected to the sealing unit 510 to drive the sealing unit 510.

[49] An elastic unit 530 such as a spring, or the like, may be coupled to one side of the rod unit 520 in order to return the opening and closing unit 500 to its original position after being opened.

[50] Meanwhile, as shown in FIG. 2 or 4, the outlet 115 may be formed on an end portion of the water guide unit 110. However, the position of the outlet 115 is not limited thereto and may be changed according to a required appropriate level.

[51] As illustrated in FIG. 2, the outlet 115 may be formed by cutting away a portion of an end of the water guide unit 110.

[52] Meanwhile, the water tank 200 may be provided to store water supplied from the water bottle 100.

[53] An installation part 300 allowing the water guide unit 110 of the water bottle 100 to be installed therein may be disposed in the water tank 200. In an embodiment, the water tank 200 may have a shape elongated in a forward and a backward direction. Here, based on a length direction of the water tank, a side in which the water bottle 100 is not installed is a front surface, and the opposite side is a rear surface.

[54] Meanwhile, the installation part 300 may be disposed in the rear surface of the water tank 200.

[55] In an embodiment, the installation part 300 may include a bottom surface 320 and a confinement wall 330 to form a recess accommodating the water guide unit 110, and may have a water tank input hole 310 formed on one end of the bottom surface 320 and communicating with the water tank 200.

[56] Here, the bottom surface 320 forms a water circulation path allowing water flowing out through the outlet 115 from the water bottle 110 to circulate to the water tank 200.

[57] In an embodiment, the bottom surface 320 may extend in a length direction of the water tank 200.

[58] Also, the confinement wall 330 is formed to surround at least a portion of the circumference of the water guide unit 110 of the water bottle 100. The confinement wall 330 may form a water confinement space confining water in the installation part 300 in association with the bottom surface 320.

- [59] To this end, the confinement wall 330 may extend upwardly from the edge of the bottom surface 320.
- [60] Here, the confinement wall 330 may be formed to be higher than the outlet 115 formed on the water guide unit 110 when the water bottle 100 is installed in the installation part 300.
- [61] The water tank input hole 310 formed on one end of the bottom surface 320 of the installation part 300 is a water inlet allowing water introduced to the installation part 300 through the outlet 115 from the water bottle 100 to flow into the water tank 200.
- [62] Meanwhile, in an embodiment, the installation part 300 may be formed in a water tank cover 600 coupled to an upper end of the water tank 200. Here, the water tank cover 600 may be coupled to an upper end of the water tank 200 at a rear surface of the water tank 200 and supports a lower end of the water bottle 100 installed in the water tank 200.
- [63] Meanwhile, the installation part 300 may include a protrusion 400.
- [64] The protrusion 400 may press the opening and closing unit formed on the water bottle 100 to open the opening and closing unit, when the water guide unit 110 is installed in the installation part 300.
- [65] In an embodiment, the protrusion 400 may be protruded from the bottom surface 320 of the installation part 300.
- [66] Here, as illustrated in FIGS. 4 and 5, when the water bottle 100 is installed in the installation unit 300, the protrusion 400 formed on the installation part 300 may pressurize the rod unit 520 of the opening and closing unit 500 to lift the rod unit 520.
- [67] Accordingly, the sealing unit 510 coupled to the rod unit 520 is lifted from the water guide unit 110 so as to be released from its contact with the water guide unit 110, opening the water guide unit 110.
- [68] Meanwhile, in the embodiment illustrated in FIGS. 4 through 6, when the water bottle 100 is installed in the installation part 300, the outlet 115 may be positioned in a front surface of the bottom surface 320 of the installation part 300 and the water tank input hole 310 may be positioned in a rear surface of the bottom surface 320.
- [69] Namely, the outlet 115 and the water tank input hole 310 may be disposed to be spaced apart by the medium of the bottom surface 320 of the installation part 300. Accordingly, when the housing 900 is sloped, there may be a difference in height between the outlet 115 and the water tank input hole 310.
- [70] Also, the outlet 115 of the water guide unit 110 may be open in a position opposite to the water tank input hole 310. Accordingly, when the housing 900 is sloped, the outlet 115 may be reliably immersed in water confined in the confinement space.
- [71] Meanwhile, referring to FIG. 2, the humidification unit 700 performs humidification with water accommodated in the water tank 200. Here, the humidification unit 700

may perform humidification according to various methods and the humidification method is not limited.

[72] An air purifying filter 80 may be provided within the housing 900 in order to purify air introduced to the housing 900.

[73] Here, a plurality of air purifying filters 800 may be provided and various types of filters may be provided.

[74] Hereinafter, an operation of supplying water to the water tank 200 of the humidification apparatus 1000 having the foregoing configuration according to an embodiment of the present invention will be described with reference to FIGS. 4 through 6.

[75] First, as illustrated in FIG. 4, in case that the water tank 200 is placed horizontally, when water accommodated in the water tank 200 fills up to the outlet 115 formed on the water guide unit 110, water blocks the outlet 115, preventing air from being introduced to the water bottle 110, so water stored in the water bottle 100 cannot flow out therefrom.

[76] Also, as illustrated in FIG. 5, when the water tank 200 is sloped forwardly (i.e., when the water tank 200 is sloped leftwardly in the drawing), namely, when the portion in which the water bottle 100 of the water tank 200 is lifted, the water tank input hole 310 is positioned higher than water level of water accommodated in the water tank 200, so water is confined in the water confinement space formed by the confinement wall 330 and the water tank input hole 310 of the installation part 300.

[77] Here, the outlet 115 is closed by water confined in the water confinement space, preventing air from flowing into the water bottle 100, and thus, water stored in the water bottle 100 cannot flow out therefrom.

[78] Thus, although the water tank 200 is sloped, water leakage from the water bottle 100 can be prevented.

[79] Meanwhile, as illustrated in FIG. 6, when the water tank 200 is sloped backwardly (i.e., when the water tank 200 is sloped rightwardly in the drawing), namely, when a front surface of the water tank 200 is lifted, since the installation part 300 is disposed in the rear surface of the water tank 200, water stored in the water tank 200 is collected to the rear surface of the water tank 200, raising a water level of water stored in the rear surface of the water tank 200.

[80] Accordingly, since the water level of water is lifted, water blocks the outlet 115, preventing water leakage.

[81] The humidification apparatus 1000 according to another embodiment of the present invention will be described with reference to FIGS. 8 and 9.

[82] As illustrated in FIGS. 8 and 9, the bottom surface 320 of the installation part 300 may be formed to be sloped downwardly toward the water tank input hole 310.

- [83] Thus, although the humidification apparatus 1000 according to an embodiment of the present invention is installed in a slightly sloped area, water can flow along the bottom surface 320 so as to be smoothly supplied to the water tank 200.
- [84] Namely, in case that the humidification apparatus 1000 is installed in an area which is sloped, rather than being completely horizontal, so it may be internally sloped forwardly of the water tank 200, if the water tank input hole 310 of the installation part 300 is formed at a position higher than the outlet 115 of the water guide unit 110, water cannot flow to the water tank input hole 310 along the installation part 300 but block the outlet 115, preventing water stored in the water bottle 100 from flowing out through the outlet 115.
- [85] In order to solve this problem, in the humidification apparatus 1000 according to another embodiment of the present invention, the bottom surface 320 of the installation part 300 is formed to be sloped downwardly toward the water tank input hole 310, so, although the humidification apparatus 1000 is installed in an area sloped at an angle within a predetermined range, the outlet 115 may be positioned to be higher than or equal to the water tank input hole 310.
- [86] For example, when the humidification apparatus 1000 according to an embodiment of the present invention is designed to smoothly perform a water supply operation although it is installed in an area sloped by 6° or less, the installation part 300 may be formed at a tilt angle of 6°.
- [87] FIGS. 10 and 11 are a perspective view and a cross-sectional view illustrating the water tank 200 of the humidification apparatus 1000 according to another embodiment of the present invention.
- [88] As illustrated in FIGS. 10 and 11, unlike the humidification apparatus 1000 according to the embodiment illustrated in FIGS. 3 through 9, the humidification apparatus 1000 according to another embodiment of the present invention has a structure in which the installation part 300 is protruded from the bottom of the water tank 200, rather than being formed in the water tank cover 600.
- [89] Here, the bottom surface 320 of the installation part 300 may be formed in a position raised by a predetermined height from the bottom of the water tank 200, and the confinement wall 330 may be protruded upwardly along the edge of the bottom surface 320.
- [90] Here, the water tank input hole 310 is formed as a portion of the confinement wall 330 is excluded.
- [91] In this manner, when the installation part 300 is integrally formed with the water tank 200, an extra component such as the water tank cover 600 for forming the installation part 300 is excluded, a number of assembly components of the apparatus can be reduced and the configuration of the apparatus is simplified.

Claims

- [Claim 1] A water leakage preventing humidification apparatus comprising:
a housing;
a water tank installed in the housing and storing water for humidification;
a water bottle having a water guide unit having an outlet formed therein to allow water to flow out therefrom, and installed in the water tank to provide water for humidification to the water tank;
an installation part disposed in the water tank and having a confinement wall formed to surround at least a portion of the circumference of the water guide unit of the water bottle and a water tank input hole formed on one end of the bottom surface along which water flowing out through the outlet flows and communicating with the water tank; and
a humidification unit provided to perform humidification with water stored in the water tank,
wherein when the housing is sloped at a predetermined angle or more, a water confinement space is formed between the confinement wall and the water tank input hole of the installation part to confine water therein.
- [Claim 2] The water leakage preventing humidification apparatus of claim 1, wherein the bottom surface of the installation part extends in a length direction of the water tank.
- [Claim 3] The water leakage preventing humidification apparatus of claim 2, wherein the outlet is positioned in a front surface of the bottom surface of the installation part, and the water tank input hole is positioned in a rear surface of the bottom surface of the installation part.
- [Claim 4] The water leakage preventing humidification apparatus of claim 3, wherein the installation part is disposed in a rear portion of the water tank.
- [Claim 5] The water leakage preventing humidification apparatus of claim 1, wherein the outlet is open in a position opposite to the water tank input hole.
- [Claim 6] The water leakage preventing humidification apparatus of claim 1, wherein the confinement wall of the installation part is formed to extend upwardly from the edge of the bottom surface of the installation part such that it is higher than the outlet, when the water bottle is installed in the installation part.

- [Claim 7] The water leakage preventing humidification apparatus of claim 1, further comprising:
a protrusion formed in the installation part and pressurizing the opening and closing unit formed on the water bottle to open the opening and closing unit, when the water guide unit is installed in the installation part.
- [Claim 8] The water leakage preventing humidification apparatus of claim 7, wherein the protrusion is protruded from the bottom surface of the installation part.
- [Claim 9] The water leakage preventing humidification apparatus of claim 2, wherein the bottom surface of the installation part is formed to be sloped downwardly toward the water tank input hole.
- [Claim 10] The water leakage preventing humidification apparatus of any one of claim 1 to 9, further comprising:
a water tank cover coupled to an upper end of the water tank, wherein the installation part is formed in the water tank cover.
- [Claim 11] The water leakage preventing humidification apparatus of any one of claim 1 to 9, wherein the installation part is protruded from the bottom of the water tank.
- [Claim 12] The water leakage preventing humidification apparatus of any one of claim 1 to 9, wherein the housing further includes an air purifying filter installed therein.

[Fig. 1]

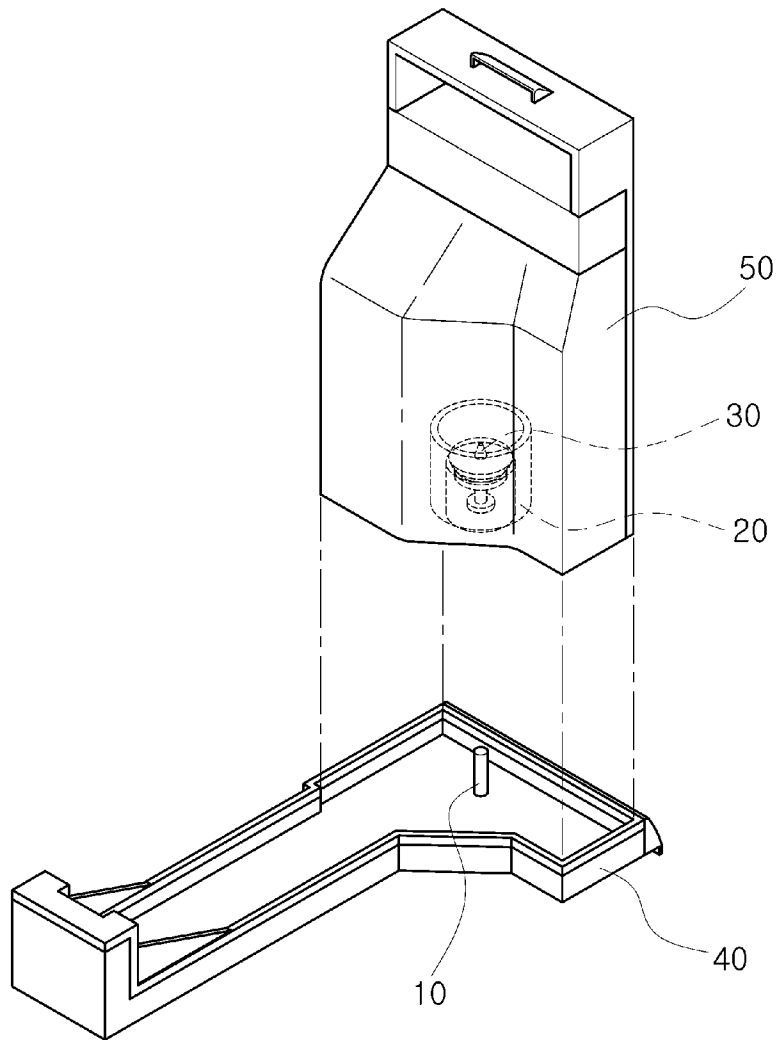

[Fig. 2]

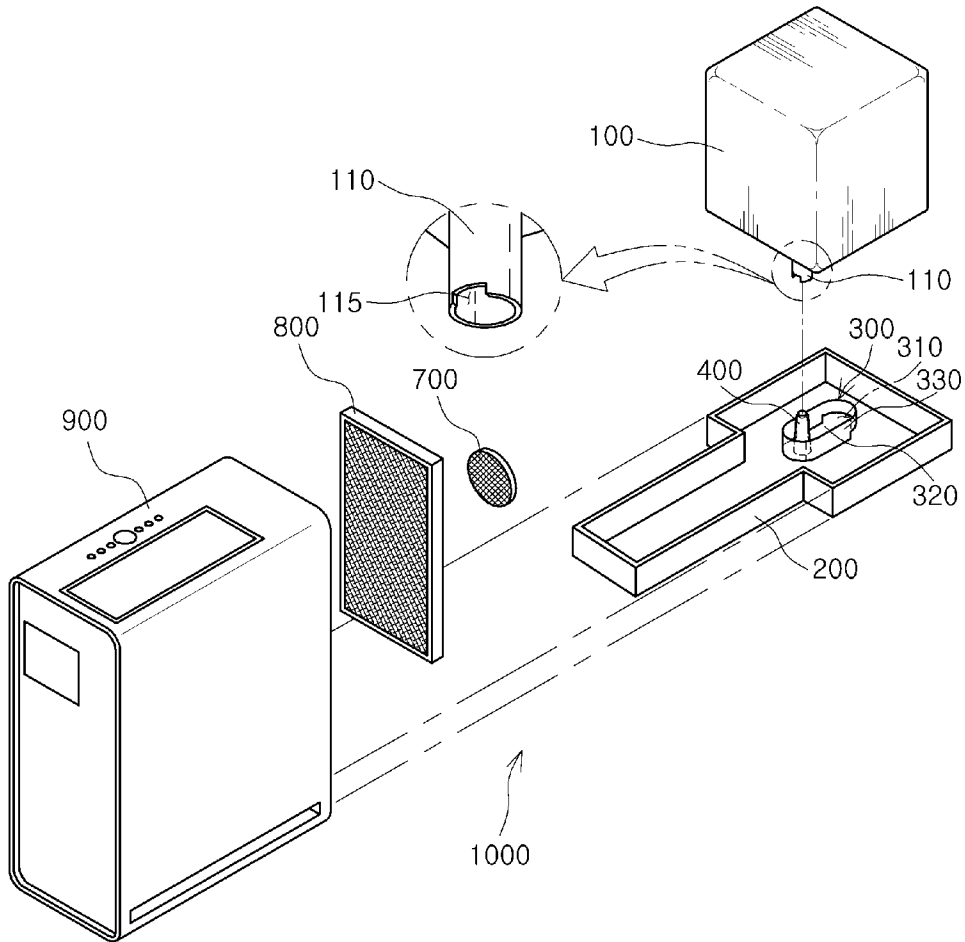

[Fig. 3]

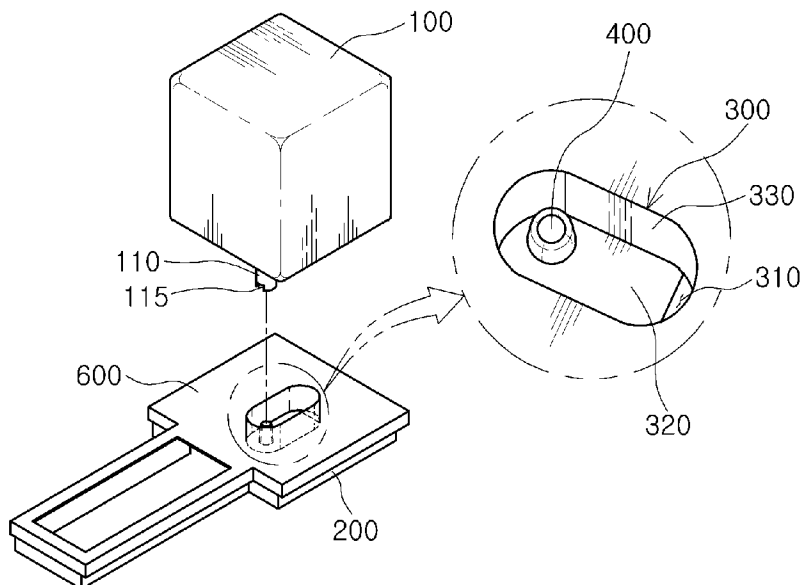

[Fig. 4]

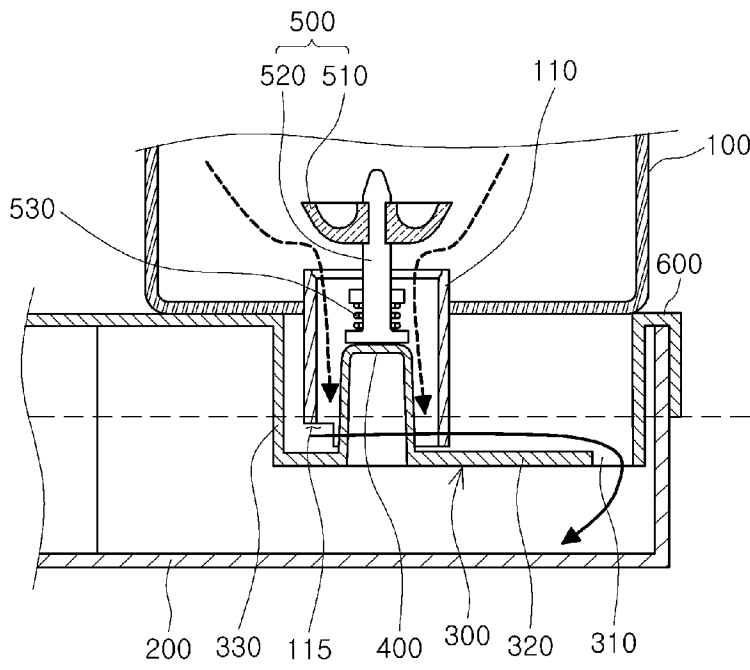

[Fig. 5]

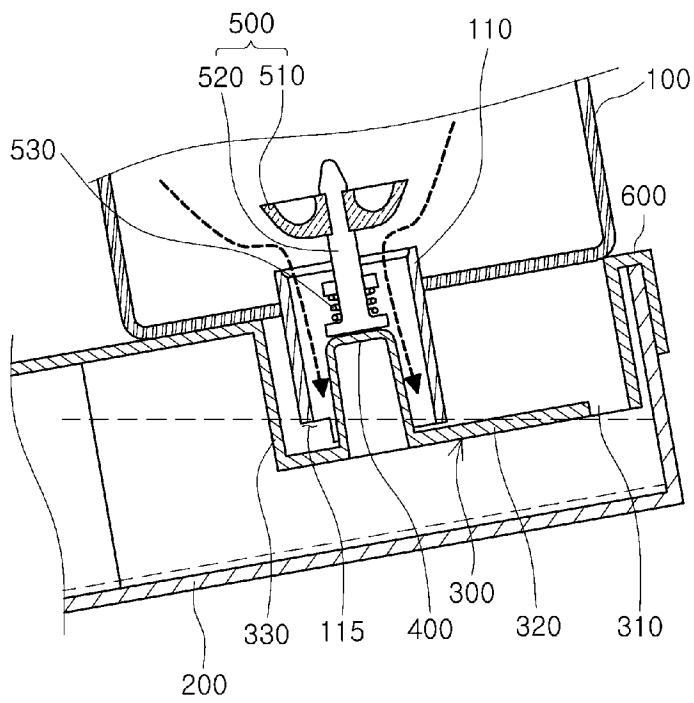

[Fig. 6]

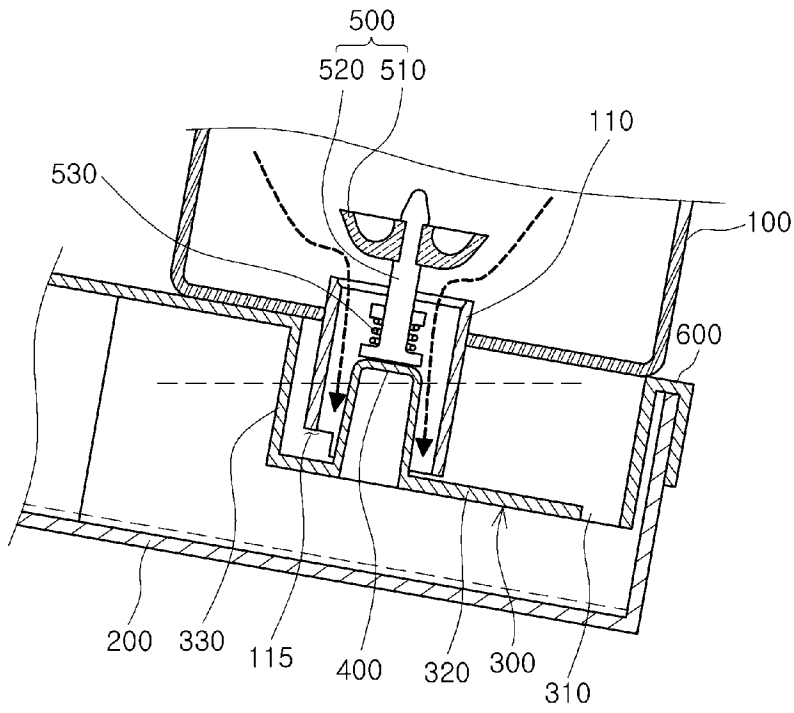

[Fig. 7]

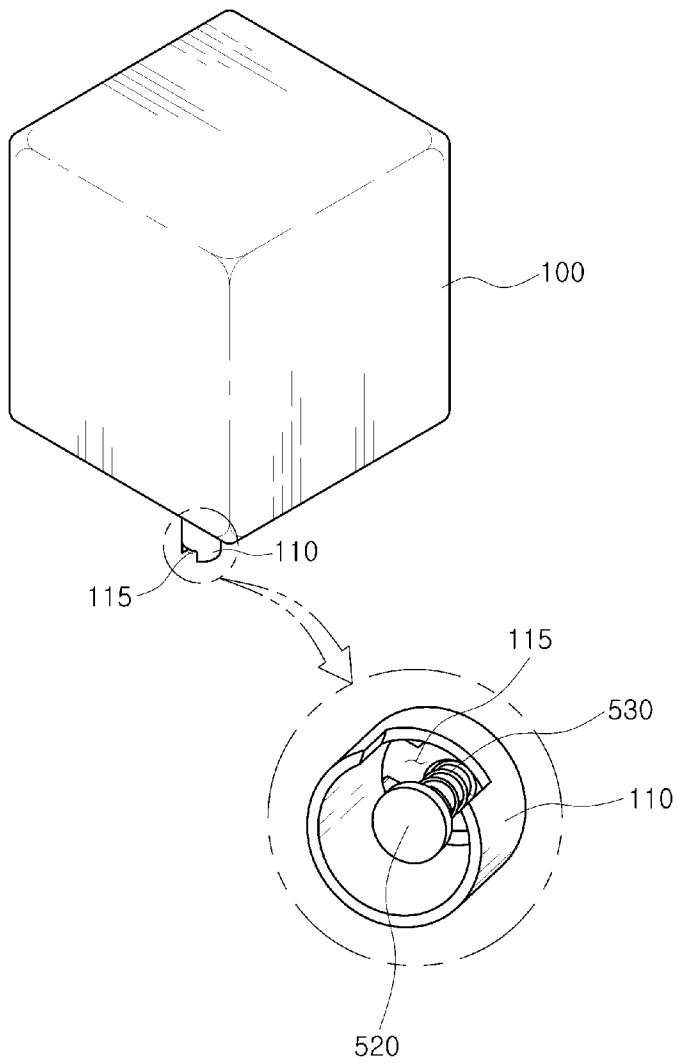

[Fig. 8]

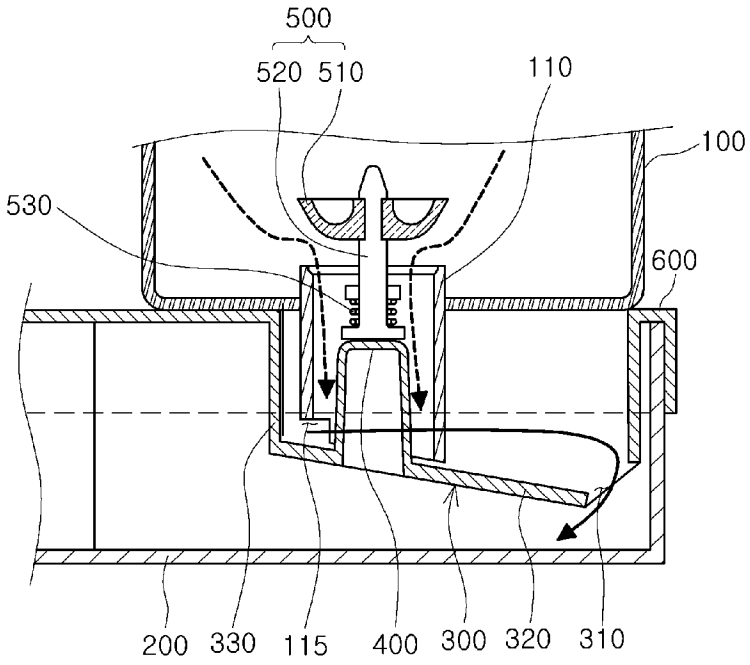

[Fig. 9]

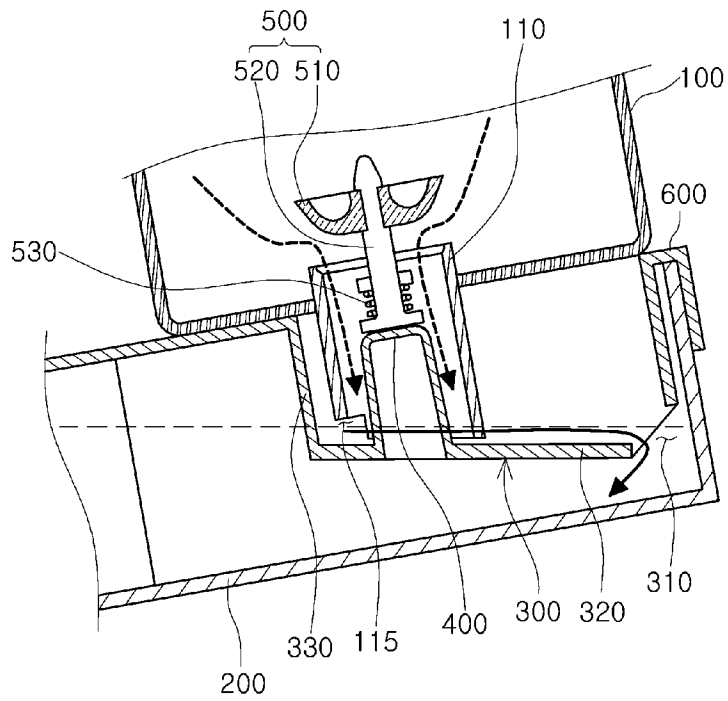

[Fig. 10]

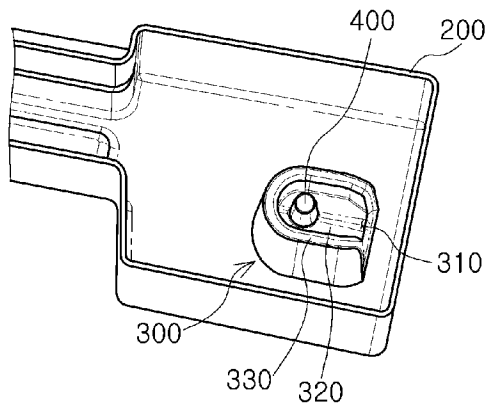

[Fig. 11]

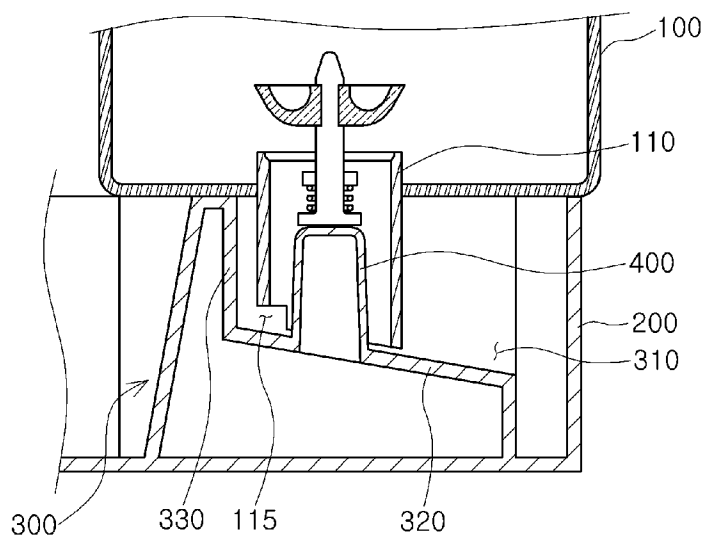

A. CLASSIFICATION OF SUBJECT MATTER*F24F 6/00(2006.01)i, F24F 13/20(2006.01)i*

According to International Patent Classification (IPC) or to both national classification and IPC

B. FIELDS SEARCHED

Minimum documentation searched (classification system followed by classification symbols)

F24F 6/00; A61L 9/14; F24F 6/04; A61M 16/00; F24F 3/14; B65D 25/42

Documentation searched other than minimum documentation to the extent that such documents are included in the fields searched

Korean utility models and applications for utility models

Japanese utility models and applications for utility models

Electronic data base consulted during the international search (name of data base and, where practicable, search terms used)

eKOMPASS(KIPO internal) & Keywords: humidification apparatus, humidifier, water tank, water bottle, and leakage

C. DOCUMENTS CONSIDERED TO BE RELEVANT

Category*	Citation of document, with indication, where appropriate, of the relevant passages	Relevant to claim No.
A	JP 2012-013361 A (PANASONIC CORP.) 19 January 2012 See abstract, paragraphs [0001],[0033]-[0047], and figures 3,5-8	1-12
A	JP 06-041068 Y2 (TOSHIBA HOME TECHNOLOGY CORP.) 26 October 1994 See claim 1 and figures 1,2.	1-12
A	US 5677982 A (LEVINE, LAWRENCE et al.) 14 October 1997 See abstract, column 3, lines 53-63, and figures 1,7.	1-12
A	JP 2006-057943 A (SHARP CORP.) 02 March 2006 See abstract and figures 3,4.	1-12
A	JP 2008-020115 A (DAINICHI CO., LTD.) 31 January 2008 See abstract and figures 4-6.	1-12

 Further documents are listed in the continuation of Box C. See patent family annex.

* Special categories of cited documents:

"A" document defining the general state of the art which is not considered to be of particular relevance

"E" earlier application or patent but published on or after the international filing date

"L" document which may throw doubts on priority claim(s) or which is cited to establish the publication date of citation or other special reason (as specified)

"O" document referring to an oral disclosure, use, exhibition or other means

"P" document published prior to the international filing date but later than the priority date claimed

"T" later document published after the international filing date or priority date and not in conflict with the application but cited to understand the principle or theory underlying the invention

"X" document of particular relevance; the claimed invention cannot be considered novel or cannot be considered to involve an inventive step when the document is taken alone

"Y" document of particular relevance; the claimed invention cannot be considered to involve an inventive step when the document is combined with one or more other such documents, such combination being obvious to a person skilled in the art

"&" document member of the same patent family

Date of the actual completion of the international search

05 April 2013 (05.04.2013)

Date of mailing of the international search report

08 April 2013 (08.04.2013)

Name and mailing address of the ISA/KR

Korean Intellectual Property Office
189 Cheongsu-ro, Seo-gu, Daejeon Metropolitan
City, 302-701, Republic of Korea

Facsimile No. 82-42-472-7140

Authorized officer

KIM, Jin Ho

Telephone No. 82-42-481-8699



INTERNATIONAL SEARCH REPORT

Information on patent family members

International application No.

PCT/KR2012/011545

Patent document cited in search report	Publication date	Patent family member(s)	Publication date
JP 2012-013361 A	19.01.2012	None	
JP 06-041068 Y2	26.10.1994	JP 02-093631 U	25.07.1990
US 5677982 A	14.10.1997	US 5859952 A	12.01.1999
JP 2006-057943 A	02.03.2006	JP 4486444 B2	23.06.2010
JP 2008-020115 A	31.01.2008	JP 4675846 B2	27.04.2011