

May 9, 1933.

H. T. PAISTE

1,908,441

SWITCH

Filed Feb. 19, 1932

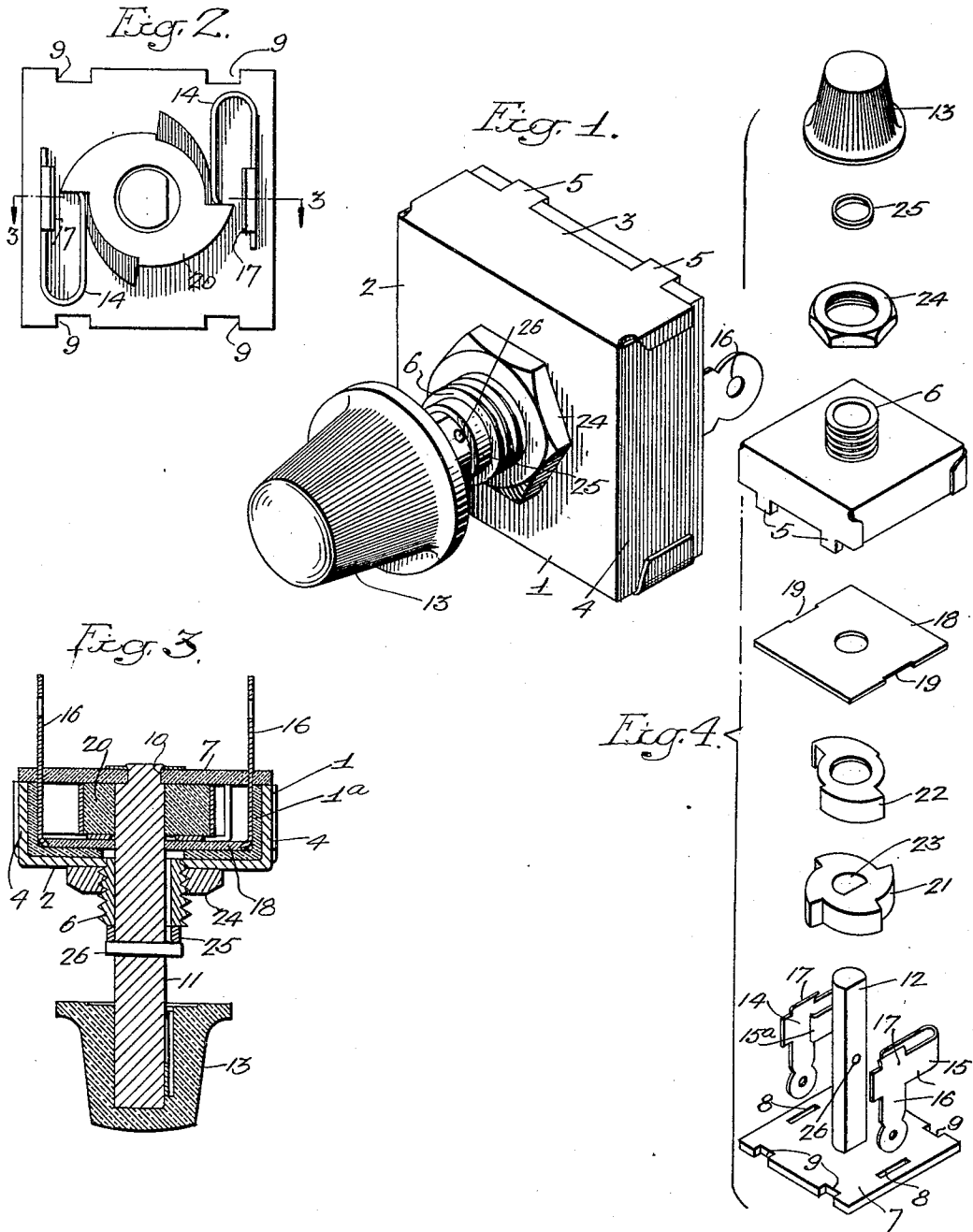

Inventor:
Henry T. Paiste,
by his Attorneys
Hosson & Hosson

UNITED STATES PATENT OFFICE

HENRY T. PAISTE, OF PHILADELPHIA, PENNSYLVANIA

SWITCH

Application filed February 19, 1932. Serial No. 594,119.

This invention relates to rotary switches and particularly to switches of this type which are suitable for controlling the current in small current-consuming devices where compactness and simplicity of the switch is essential. While not limited thereto, the invention is particularly directed to radio receivers and like equipment where the need of switches of the type in question is relatively great.

The general object of the invention is to provide a simple and compact switch which is susceptible of economic manufacture and assembly and at the same time highly efficient in operation.

A more specific object of the invention is to provide a switch having novel features of construction which impart to it the desired characteristics.

These and other objects of the invention, as well as the novel features of the improved switch, will appear more clearly hereinafter. Reference may be had to the following detailed description and accompanying drawing for a full and complete disclosure of a specific embodiment of the invention.

In the drawing:

Fig. 1 is a perspective view of the assembled switch;

Fig. 2 is a face view of the switch assembly with the casing removed;

Fig. 3 is a sectional view of the switch taken along line 3—3 of Fig. 2; and

Fig. 4 is an exploded view of the switch, showing the various parts thereof in perspective.

Referring to the several views of the drawing, the switch comprises a metallic casing 1 lined with insulation 1a and having a front wall 2 and pairs of side walls 3 and 4, respectively. Side walls 3, one of which is visible, are each provided with extending prongs or projections 5, whose purpose will be clearly apparent hereinafter. Casing 1 is preferably made by stamping a suitable blank from sheet metal and then bending the blank to the desired shape as illustrated. The front face 2 of the casing is centrally apertured and carries an extending threaded nipple 6, the purpose of which will appear

hereinafter. An insulating cover plate 7 (see Fig. 4) having a pair of spaced slit openings 8 therein and being recessed, as at 9, serves to support the essential elements of the switch and also serves as a rear wall for the casing. As shown clearly in Fig. 1, when the switch is assembled, the projections 5 extend into recesses 9 of the cover plate to securely lock the same relative to the casing.

The cover plate 7 is centrally apertured, as at 10, (see Fig. 3) and rotatably carries an operating shaft 11 which extends through the casing and nipple 6. The shaft is flattened longitudinally, as at 12, to adapt it for carrying the elements mentioned hereinafter. The shaft carries at its outer end a suitable operating knob 13. A pair of spring contact elements 14, shaped as clearly illustrated in Fig. 4, are disposed within the casing. Each of these contact elements comprises a U-shaped body 15, an extending terminal finger 16 and a slightly curved detent 17. The free end of the U-shaped body is curved or bent as at 15a. These elements are preferably made as stampings from suitable sheet metal, such as copper. When the device is assembled, terminal fingers 16 of the contact elements extend externally of the casing through slits 8 of the cover plate 7. The purpose of these terminal fingers is, of course, to enable the ready attachment of conductors to the contact elements. An insulating retainer plate 18 is nested within the casing, as shown in Fig. 3. This plate has opposite sides recessed, as at 19 (see Fig. 4), the recesses receiving the detents 17 of the contact elements to aid in immovably mounting these elements. It will be apparent then that when the contact elements are mounted in relation to the other elements, as above described, they are rigidly and immovably supported by virtue of plate 7 and the cooperating retainer plate 18, the contact elements being firmly held between these two parallel spaced plates.

A ratchet switch member, designated generally by numeral 20, (see Fig. 2) is mounted upon shaft 11 so as to turn therewith. The cam surfaces of the ratchet member fric-

tionally engage the spring fingers of contact elements 14, as clearly shown in Fig. 2. The ratchet member preferably comprises an insulating block 21 (see Fig. 4) and a metallic stamping 22 adapted to embrace the insulating cam surfaces. Block 21 may be cut from a suitable fibre sheet, while stamping 22 may be formed by stamping the desired blank from sheet metal and thereafter bending it to the desired shape. Block 21 has a central aperture 23 which conforms in shape with shaft 11 and is adapted to slidably receive the shaft. By means of this construction, the ratchet switch member is securely mounted upon the shaft for rotation therewith.

A nut 24 may be screw threaded upon nipple 6 and a collar 25 may be positioned upon shaft 11 in engagement with the end of the nipple. Shaft 11 is provided with a transverse aperture 26 immediately adjacent collar 25, the purpose of which aperture is to receive a suitable cotter key or pin to firmly lock the various elements together.

The manner in which the various elements of the device are assembled is clearly apparent from the above description and the illustration of Fig. 4. It will be noted that the switch comprises relatively few simple parts, all of which may be easily and economically manufactured. By virtue of its peculiar construction, as illustrated and described, the switch is at all times efficient in operation to positively make and break the circuit at both contact points simultaneously. There is little likelihood that the device will get out of order or that any of the parts thereof become dislodged to impair its operation. A very important feature of the device is the manner in which the stationary contact elements 14 of the switch are formed and immovably mounted. By virtue of the construction utilized, the contact elements are held rigidly and there is no possibility of them turning to impair operation of the switch. The elements make and break the circuit in a positive manner and they function simultaneously. The curved ends 15a of the elements enhance their operation.

While the invention has been illustrated and described herein in its application to a specific preferred embodiment, it will be understood that various changes and modifications in construction may be resorted to without departing from the spirit and scope of the invention. Only such limitations as are contained in the appended claims are to be considered as limiting the invention.

I claim:

1. An electric switch, comprising a casing, an insulating plate having a recess therein disposed within said casing, an insulating cover plate for said casing having an opening therein, a spring contact element disposed between said plates, said contact ele-

ment having a terminal finger extending externally of said casing through said opening and having a detent extending into said recess, whereby the main body of said contact element is immovably supported between said plates, and a movable contact element disposed within said casing and adapted to frictionally engage said spring contact element.

2. An electric switch, comprising a casing, an insulating plate having spaced recesses therein disposed within said casing, an insulating cover plate for said casing having a pair of spaced openings therein, a pair of spring contact elements disposed between said plates, said contact elements having terminal fingers extending externally of said casing through said openings and having detents extending into said recesses, whereby the main body of each of said contact elements is immovably supported between said plates, and a movable contact element disposed between said spring contact elements and adapted to frictionally engage said elements.

3. An electric switch, comprising a casing having front and side walls, an insulating plate having spaced recesses therein disposed within said casing, an insulating cover plate for said casing having a pair of spaced openings therein, a pair of spring contact elements disposed between said plates, said contact elements having terminal fingers extending externally of said casing through said openings and having detents extending into said recesses, whereby the main body of each of said contact elements is immovably supported between said plates, a shaft rotatably carried by said cover plate and extending through said casing, and a ratchet switch member carried by said shaft and frictionally engaging said contact elements.

4. An electric switch, comprising a casing having front and side walls, an insulating plate having spaced recesses therein disposed within said casing, an insulating cover plate for said casing having a pair of spaced openings therein, a pair of U-shaped spring contact elements disposed between said plates, said contact elements having terminal fingers extending externally of said casing through said openings and having detents extending into said recesses, whereby the main body of each of said contact elements is immovably supported between said plates, a shaft rotatably carried by said cover plate and extending through said casing, and a ratchet switch member carried by said shaft and frictionally engaging said contact elements.

HENRY T. PAISTE.