

F. KUHN & J. A. HAND.
SAD IRON.
APPLICATION FILED FEB. 21, 1918.

1,288,043.

Patented Dec. 17, 1918.

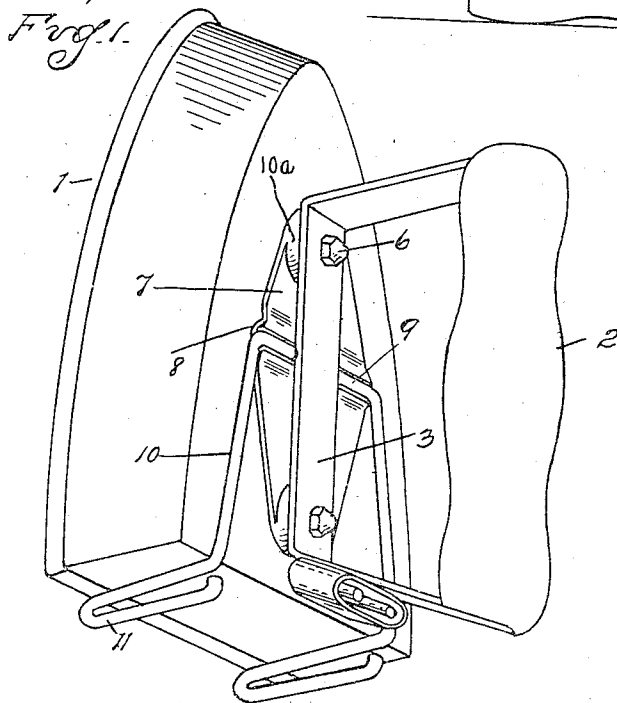
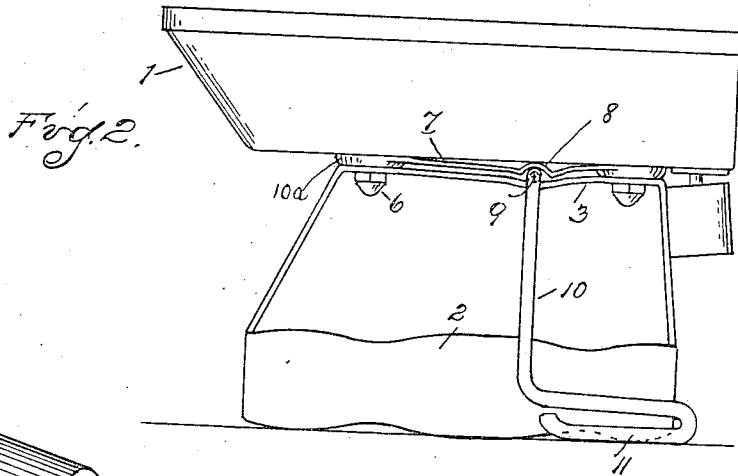
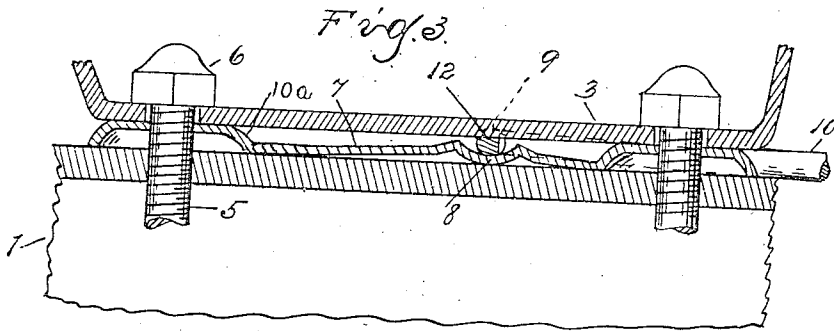

Inventors
Frank Kuhn
Jay A. Hand

By Whittemore, Hulbert, & Whittemore

Attorneys

UNITED STATES PATENT OFFICE.

FRANK KUHN AND JAY A. HAND, OF DETROIT, MICHIGAN, ASSIGNORS TO AMERICAN ELECTRICAL HEATER COMPANY, OF DETROIT, MICHIGAN, A CORPORATION OF MICHIGAN.

SAD-IRON.

1,288,043.

Specification of Letters Patent.

Patented Dec. 17, 1918.

Application filed February 21, 1918. Serial No. 218,398.

To all whom it may concern:

Be it known that we, FRANK KUHN and JAY A. HAND, both citizens of the United States of America, residing at Detroit, in the county of Wayne and State of Michigan, have invented certain new and useful improvements in Sad-Irons, of which the following is a specification, reference being had therein to the accompanying drawings.

The invention relates to sad-irons and particularly relates to such sad-irons as have permanently connected therewith a supporting member or stand.

It is the object of the invention to provide a sad-iron having permanently mounted thereon a pivotal supporting member having two positions of adjustment adapting the sad-iron to be supported either in an inverted position or in an upright position in which it is spaced from the supporting surface.

In the accompanying drawings:

Figure 1 is a perspective view showing the sad-iron adapted by its supporting member to be supported in an upright position;

Fig. 2 is a view of the sad-iron in side elevation retained in inverted position conjointly by said supporting member and the handle of the sad-iron;

Fig. 3 is a fragmentary longitudinal vertical section showing the co-action between the handle member and body of the sad-iron in establishing a pivotal mounting for the adjustable supporting member.

In these views the reference character 1 designates the body of a sad-iron, 2 the grip portion of the handle member and 3 the bracket portion of the handle member formed by a substantially U-shaped bar which is engaged with a pair of screws 5 projecting through the top of the sad-iron and is clamped by nuts 6 terminally engaging said screws. Between the handle member and body of the sad-iron there is clamped a sheet metal plate 7 engaged by the screws 5 and having its central portion formed with a trough 8 extended transversely of the iron and forming a seat for the pivotal central portion 9 of a substantially U-shaped supporting member 10, the free ends of which are provided with return-bent portions 11 disposed in an angular relation to the members 10 to serve as supporting feet. The member 10 is proportioned in length so that when adjusted at a

right angle to the body of the iron, as illustrated in Fig. 2, said member will be adapted to coact with the handle member to form a three-point support for the sad-iron when the latter occupies an inverted position. The pivotal axis of the member 10 is spaced longitudinally from the rear or flat end of the sad-iron a distance such that the feet 11 will occupy a position closely adjacent to said flat end face of the body 1 when the leg portions of the member 10 extend parallel and adjacent to the top of said body. At its points of engagement with the screws 5 the plate 7 is upwardly embossed, as indicated at 10^a, whereby the bracket portion 3 of the handle member is spaced sufficiently from the body 1 to permit the pivotal portion of the supporting member 10 to be interposed between said bracket member and body. The bracket portion 3 of the handle member serves not only to prevent displacement of the pivotal portion of the supporting member 10 from the trough 8 but further coacts with said pivotal portion to yieldably resist displacement of the supporting member from either of its two positions of adjustment, the pivotal member 9 being formed with cam faces 12 perpendicular one to the other and respectively engaging the bracket portion 3 of the handle member in the two positions of adjustment of the supporting member. The resiliency of the member 3 will be sufficient to allow an upward yielding of said member in its central portion when the member 10 is shifted from one to the other of its two positions.

In addition to its function of providing a pivotal seat for the member 10, the plate 7 further forms air spaces between the body of the iron and the handle member so as to decrease the transmission of heat from the former to the latter.

What we claim as our invention is:

1. The combination with a sad-iron, of a member pivotally carried thereby adjustable to support the iron in a plurality of positions, and a handle member coacting with the pivotal portion of said adjustable member to yieldably resist displacement thereof from said positions.

2. The combination with a sad-iron, of a supporting member pivotally mounted upon the top thereof, said supporting member comprising a U-shaped member having the legs thereof terminally bent to form feet,

- 2
- said member being adjustable through a substantially right angle and lying in one position adjacent the top of the iron with its feet in proximity to an end face thereof and extending substantially across said face to support the iron on end and in spaced relation to the supporting surface and in its other position being substantially perpendicular to the top of the iron with its feet substantially parallel to said top.
3. The combination with a sad-iron, comprising a body and a handle projecting from the top thereof, said handle comprising a grip and a bracket portion, of a member pivoted intermediate the body of the iron and the bracket portion of the handle and adjustable from a position adjacent the top of said body to a position substantially transverse to said top, said member co-acting with the handle in its last-mentioned position to support the iron when inverted.
4. The combination with a sad-iron, comprising a body and a handle projecting from the top thereof, said handle comprising a grip and a bracket portion, of a metal plate interposed between the body of the iron and the bracket portion of the handle, said plate being transversely grooved, and a member pivoted within said transverse groove and retained therein by the bracket portion of the handle, said member being adjustable to support the iron either on end or in inverted position.
5. The combination with a sad-iron, of a supporting member pivotally carried thereby, said member being terminally formed with a foot projecting substantially at a right angle thereto, said member lying in one position closely adjacent to the top of the body of the iron and having said foot extending close adjacent to an end face of said iron and in another position co-acting with the handle to support the iron in inverted position.
6. The combination with a sad-iron, a body and a handle projecting from the top thereof, said handle comprising a grip and a bracket portion, of a member pivoted between the body of the iron and the bracket portion of the handle adjustable to support the iron either on end or inverted, said member having cam faces engaging the bracket portion of the handle in its respective positions of adjustment, said bracket portion yieldably resisting pivotal movement from said positions.
7. The combination with a sad-iron, of a yieldable member extending adjacent the top surface of said iron and a supporting member having a pivotal portion engaged between the top of the iron and said yieldable member, said member being adjustable to support the iron either on end or inverted, the pivotal portion thereof having cam faces engaging said yieldable member in the respective limiting positions of said portion, movement of the portion between said positions being resisted by said yieldable member.
8. The combination with a sad-iron comprising a body and a handle projecting from the top thereof, said handle comprising a grip and a bracket portion, of a metal plate interposed between the body of the iron and the bracket portion of the handle, said plate having adjacent intermediate projections and having bosses at its extremities maintaining a spaced relation between the bracket portion of the handle and the body of the iron, and a member pivoted between the bracket portion of the handle and said plate and engaged between said intermediate projections of the plate, said member being adjustable to support the iron either on end or in inverted position.
- In testimony whereof we affix our signatures.

FRANK KUHN.
JAY A. HAND.