

[72] Inventor **John H. Bickford**
 Middletown, Conn.
 [21] Appl. No. **868,070**
 [22] Filed **Oct. 21, 1969**
 [45] Patented **Jan. 4, 1972**
 [73] Assignee **Veeder Industries, Inc.**
 Hartford, Conn.

[56] **References Cited**
UNITED STATES PATENTS
 3,225,178 12/1965 Glot 235/92 R
Primary Examiner—Maynard R. Wilbur
Assistant Examiner—Robert F. Gnuse
Attorney—Prutzman, Hayes, Kalb & Chilton

[54] **COMPUTING DEVICE**
 29 Claims, 5 Drawing Figs.
 [52] U.S. Cl. **235/92 FL,**
 235/92 R, 235/92 V, 235/151.34
 [51] Int. Cl. **G06m 1/272**
 [50] Field of Search **235/92 V,**
 92 FL, 92 WT, 151.34

ABSTRACT: A cost computing device for a fuel-dispensing system having a rotary disc with a plurality of light apertures arranged in four light aperture circles and a plurality of output heads for different places respectively of a multiple place unit volume fuel price range—each having a bank of four lamps for the four aperture circles respectively and a photoelectric cell adapted to be selectively operated by the light apertures of each aperture circle when the corresponding lamp is energized to generate an output pulse train. A bank of presettable indicator switches is provided for selectively energizing the lamps to establish the unit volume price and for posting the established unit volume price.

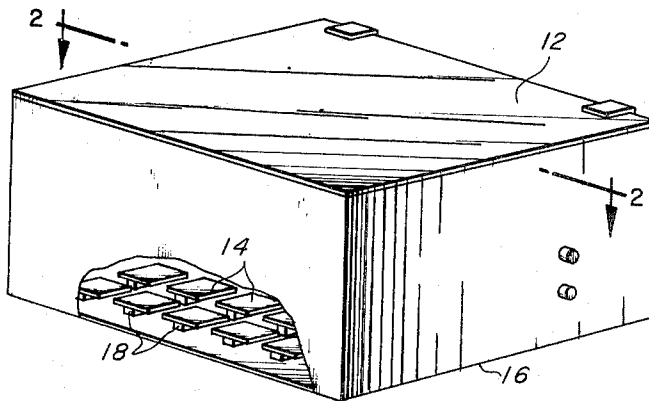
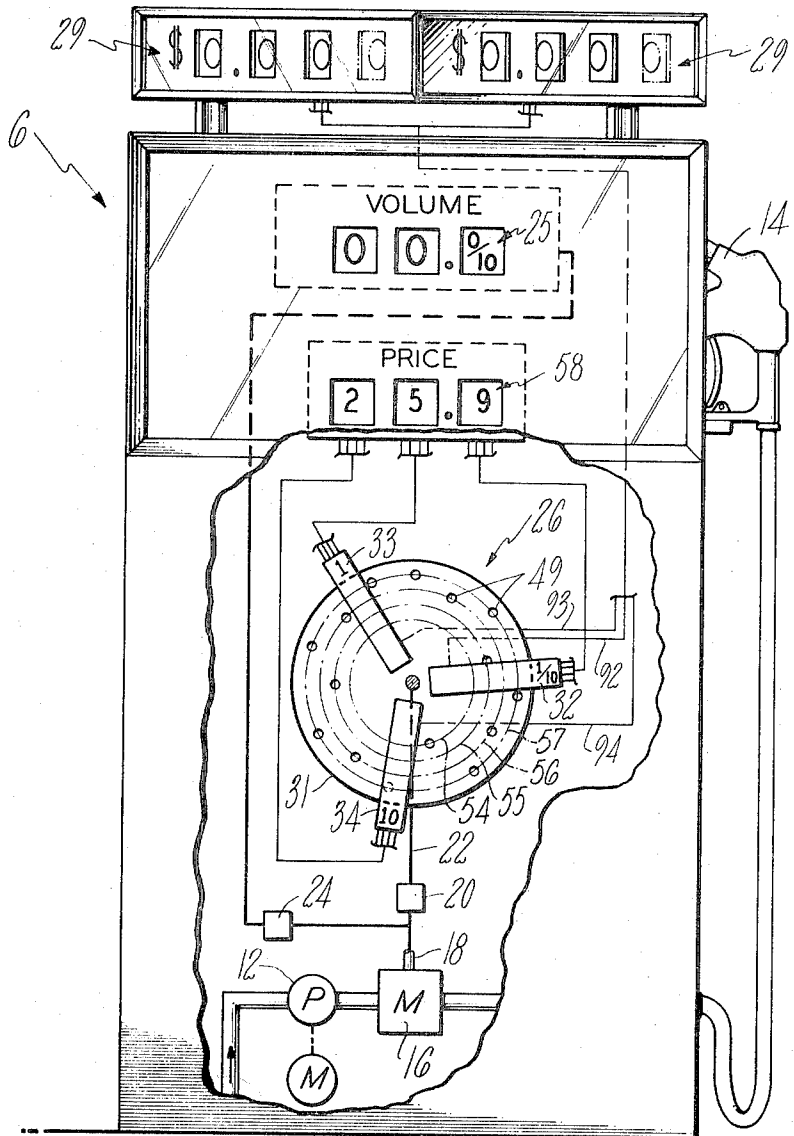

FIG. 1



INVENTOR.
JOHN H. BICKFORD

BY *Putzmann, Hayes, Hall and Chilton*

ATTORNEYS

FIG. 2

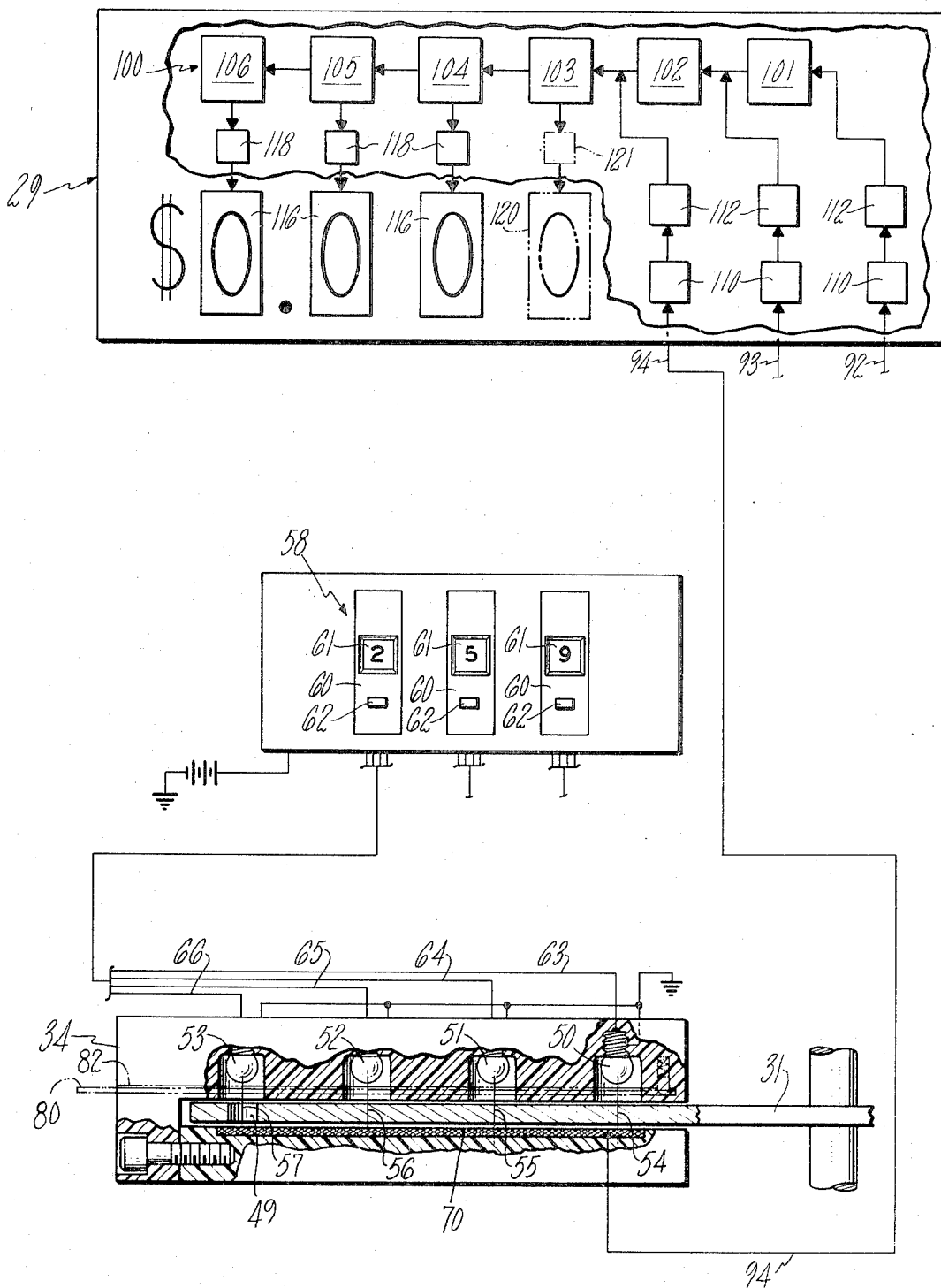

FIG. 3

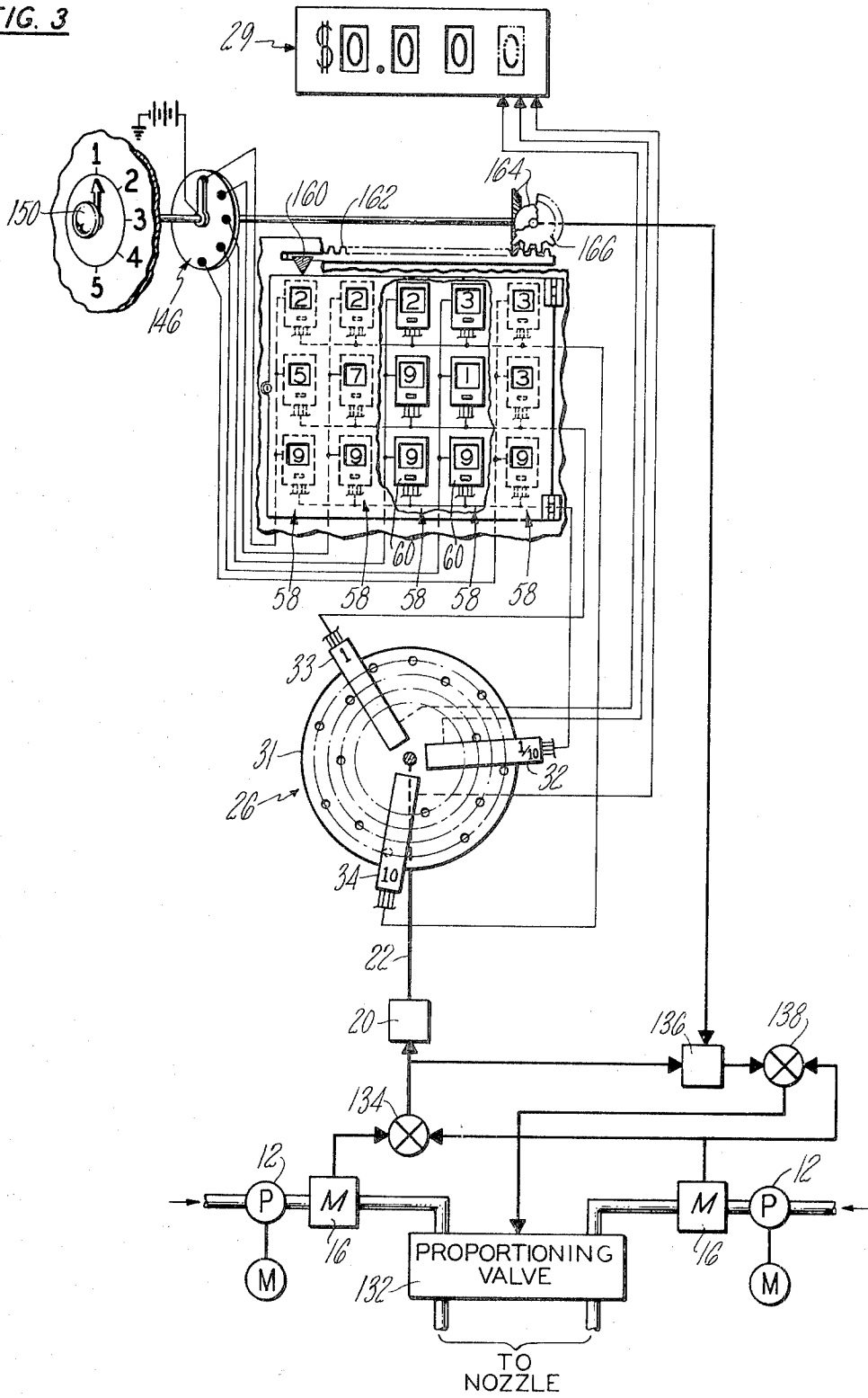

FIG. 4

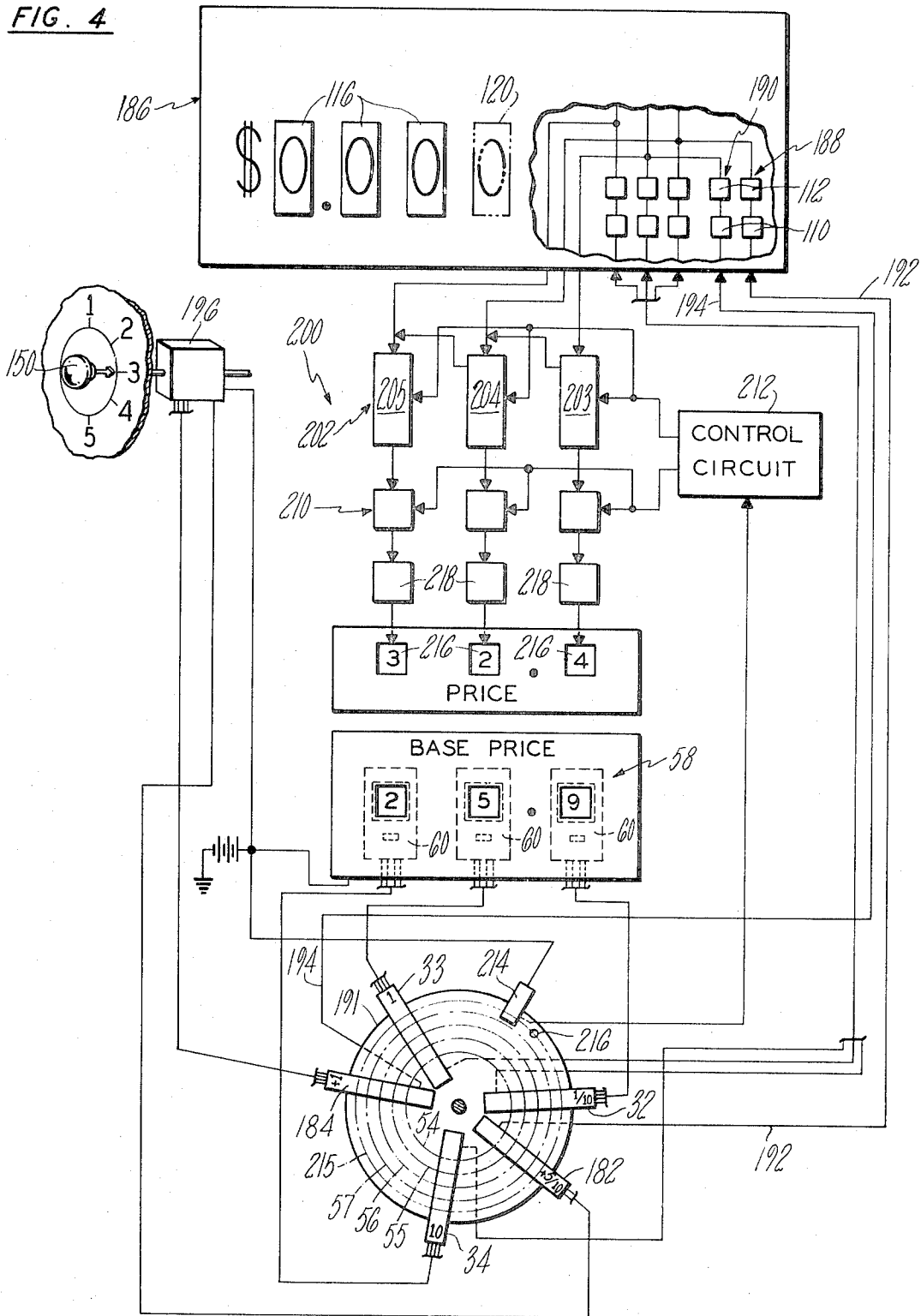
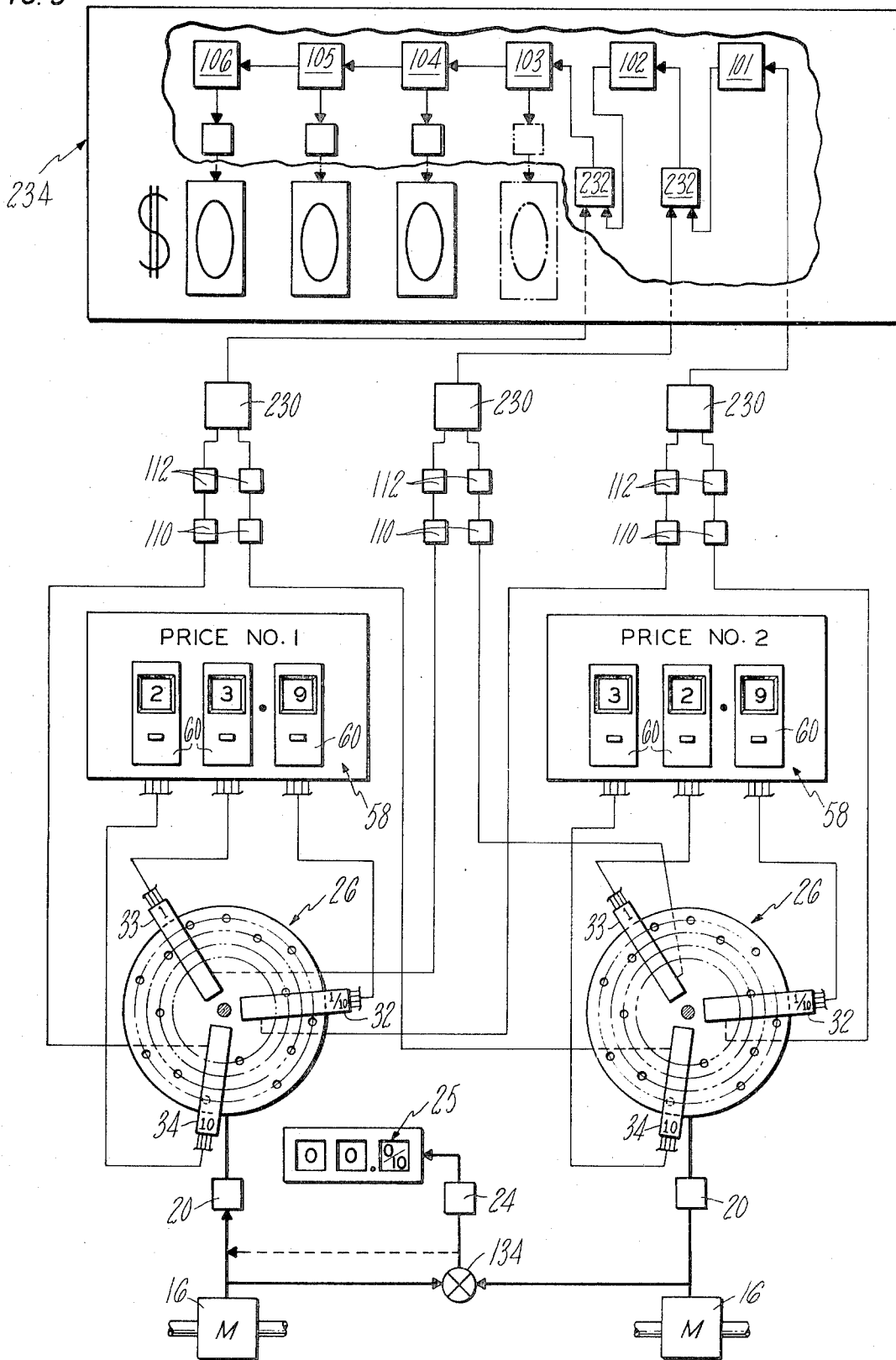

FIG. 5



COMPUTING DEVICE

BRIEF SUMMARY OF THE INVENTION

The present invention relates to computing devices having notable utility in fuel-dispensing apparatus for computing the cost of the fuel dispensed in accordance with the volumetric amount of fuel dispenses and a unit volume price established by the setting of the computing device.

It is a principal aim of the present invention to provide a new and improved computing device for fuel-dispensing apparatus having an economical and reliable construction and readily presettable for establishing the unit volume price of fuel.

It is another aim of the present invention to provide a new and improved variator for a computing device.

It is a further aim of the present invention to provide a new and improved cost variator of the type useful in fuel-dispensing apparatus and adapted for generating pulses for operating a cost counter for obtaining the total cost of the fluid delivered and for establishing a unit volume price by varying the number of pulses for each unit volume of fluid dispensed. The present invention may for example employ a fluid pulse generator or for example employ an electrical pulse generator in which photoelectric means, capacitance means, magnetic induction, or mechanically actuated switches are used to generate the pulses.

It is another aim of the present invention to provide a variator of the pulse generator type having a new and improved price posting system for posting the unit volume price established by the variator setting.

It is a further aim of the present invention to provide a new and improved variator for fuel-dispensing apparatus permitting flexibility in the manner and location of the cost register.

It is another aim of the present invention to provide a new and improved computing device for fluid-dispensing systems of the type adapted to deliver various blends of separate fluids.

Other objects will be in part obvious and in part pointed out more in detail hereinafter.

A better understanding of the invention will be obtained from the following detailed description and the accompanying drawings of illustrative applications of the invention.

BRIEF DESCRIPTION OF THE DRAWINGS

In the drawings:

FIG. 1 is an elevation view, partly broken away and partly shown in schematic, of a fuel pump employing an embodiment of the computing device of the present invention;

FIG. 2 shows a transverse section view, partly broken away and partly in section, of a variator rotor and output head of the computing device, an elevation view of a combined price posting and price setting means of the variator and a generally schematic view of a cost register of the computing device;

FIG. 3 is a generally schematic view, partly broken away, of a fuel dispensing system for dispensing various blends of two separate grades of fuel and employing a second embodiment of the computing device of the present invention;

FIG. 4 is a generally schematic view partly broken away and partly in section, showing another embodiment of the computing device of the present invention having particular utility in fuel-blending systems; and

FIG. 5 is a generally schematic view showing a portion of a fuel blending system incorporating another embodiment of the computing device of the present invention.

DESCRIPTION OF THE PREFERRED EMBODIMENTS

Referring now to the drawings in detail wherein like numerals represent like parts, and referring particularly to FIGS. 1 and 2, a fuel pump 6 incorporating an embodiment of a computing device of the present invention is shown comprising a motor-driven pump 12 for delivering fuel to a dispensing nozzle 14 and a meter 16 for metering the amount of fuel delivered. The meter output shaft 18 is connected via suitable

gearing 20 for rotating a computer input shaft 22 and via suitable gearing 24 for driving a volume counter 25 for registering the volumetric amount of fuel dispensed and which is preferably resettable for being reset to zero prior to the commencement of each fuel delivery.

The computing device comprises a variator 26 and a pair of cost registers 29 (which are shown mounted to facilitate reading the total cost of the fuel delivered from sidewise of the pump) for registering the total cost of each fuel delivery and which are also preferably resettable for being reset to zero prior to the commencement of each fuel delivery.

The variator 26 comprises a unitary rotor or disc 31 driven by the shaft 22 and a plurality of elongated radially extending output heads 32, 33, 34 angularly spaced about the axis of rotation of the disc 31. An output head is provided for each of the three lowest places of the four-place unit volume price range of the variator and is set in accordance with the desired unit volume price. For example, if a three-place unit volume price of 25.9 (e.g., 25.9 cents per gallon) is to be established, the "tenths" or lowest place head 32 would be set at "9," the "units" or middle place head 33 would be set at "37 5" and the "tens" or highest place head 34 would be set at "2."

Referring to FIG. 2, a bank of four radially spaced lamps 50-53 are mounted in each output head 32-34, and 15 light-transmitting apertures 49 are provided on the disc 31 in four concentric pulse actuator circles 54-57 in radial alignment with the lamps 50-53 respectively. As shown in full lines in FIG. 2, a bank 58 of three price selector switches 60 is provided for selectively energizing the lamps of the three lamp banks. The price selector switches 60 are preferably binary switches of the type shown and described in U.S. Pat. No. 3,445,636 of Joseph A. Richards entitled Single Wheel Counter Circuit and having a number wheel 61 providing a numerical readout of the binary switch position and suitable means such as a pushbutton 62 for selectively setting the switch and number wheel. The output leads 63-66 of the binary switches have binary values of 1, 2, 4 and 8 respectively such that, for example, lead 63 would be energized when the number wheel 61 is set at "1," the lead 64 would be energized when the number wheel is set at "2," the leads 63 and 64 would be energized when the number wheel is set at "3," etc.

The pulse actuator circles 54-57 preferably have one, two, four and eight light apertures respectively, and therefore, numbers of apertures equal to the "binary values" of the respective lamps 50-53. The light apertures are shown in FIG. 1 positioned with equiangular spacing of 24°, and the output heads 32-34 are angularly spaced so that only one aperture appears in line with a lamp at any one time. For example, the output heads 32-34 may, as shown in FIG. 1, have an angular spacing of 128°, 128° and 104° such that one of the light apertures would appear in line with one of the lamps each 8° of rotation of the disc 31. Alternatively the light apertures could be angularly spaced within a sector (for example a 90° sector) of the disc and the output heads angularly spaced to provide for operating the heads in sequence with the light aperture sector.

A photoelectric pickup 70, which is preferably a single photoelectric cell as shown in FIG. 2, is provided in each output head in alignment with the corresponding bank of lamps 50-53 on the opposite side of the disc 31. Each photoelectric pickup 70 is therefore positioned to be actuated by each light aperture on the disc 31 to generate a train of spaced electrical pulses. The number of such pulses for each revolution of the rotor 31 may vary from zero through 15 depending on which, if any, of the pulse actuator circles 54-57 are activated by energization of the corresponding lamps. Thus, where all four of the circles are activated for operating a particular photoelectric pickup 70, the pickup will generate 15 electrical pulses for each revolution of the disc 31; and, for example, by activation of pulse actuator circle 54 (having one light aperture) and pulse actuator circle 57 (having eight light apertures) the photoelectric pickup 70 will be operated to generate nine angularly spaced electrical pulses for each revolution of the disc 31.

The number of pulses generated by each pickup for each revolution of the disc 31 therefore depends upon the setting of the corresponding selector switch 60 and is the same as the numerical reading of the switch number wheel. Thus, in the example shown in FIGS. 1 and 2, with the bank 58 of price selector switches 60 set at 25.9, the "tenths" output head 32 would generate nine pulses for each revolution of the disc 31, the "units" output head 33 would generate five pulses for each revolution of the disc, and the "tens" output head 34 would generate two pulses for each revolution of the disc 31. (Since the available single revolution pulse range is zero through 15, the selector switch 60 for at least the highest place output head 34 preferably has a range of zero through 15 to provide for setting and posting unit volume prices in a price range of 000.0 to 159.9.)

In lieu of the price selector switches 60, a suitable price selector mask 80 could be provided (as shown in broken lines in FIG. 2) for selectively inhibiting the lamps 50-53, in which case all of the lamps would remain energized and an appropriate mask 80 would be inserted into a suitable slot 82 in the output head to provide for masking and unmasking selected lamps and for thereby selectively activating and deactivating the selected pulse actuator circles for operating the corresponding pickup 70.

In operation the "tenths," "units" and "tens" output heads 32-34 respectively are set in accordance with the desired unit volume price (prior to the commencement of the fuel delivery) and three separate pulse trains with noncoincident electrical pulses are generated in the pickup output leads 92-94 during the delivery of fuel. In the described embodiment the gearing 20 preferably provides for rotating the disk 31 100 revolutions for each unit volume (for which the fuel is priced) of fuel delivered (although for example the disc 31 may be driven to rotate 10 revolutions for each unit volume of fuel dispensed where a lower degree of accuracy is desired or driven to rotate 50 revolutions for each unit volume of fuel dispensed where twice as many light apertures are provided in each pulse actuator circle) such that with a unit volume price setting of 25.9 cents per gallon, pulse trains of 900 pulses, 500 pulses and 200 pulses would be generated by the three pickups 70 for each gallon of fuel dispensed.

The output leads 92-94 are connected to the registers 29 for indexing the registers to provide a readout of the total cost amount of fuel delivered in accordance with unit volume fuel price established by the variator setting. For this purpose each register 29 is provided with a suitable counter 100 which in the described embodiment has six decades 101-106 (of increasing order from right to left as viewed in FIG. 2) suitably connected for generating transfers from adjacent lower to higher order decades. The output heads 32-34 are connected via parallel entry to the three lowest order decades 101-103 respectively and therefore in accordance with the relative values or weights of the corresponding places of the established multiple place price. Schmidt triggers 110 and one-shot multivibrators 112 are shown provided in the circuits to the decades 101-103 to form suitable electrical pulses for avoiding miscounting or overcounting in the operation of the counter 100.

In the described example with the variator set at a unit volume price of 25.9, the "tenths" output head 32 will index the lowest order decade 101, 900 steps for each unit volume of fuel dispensed; the "units" output head 33 will index the decade 102, 500 steps for each unit volume of fuel dispensed and the "tens" output head 34 will index the decade 103, 200 steps for each gallon of fuel dispensed. As a transfer step is transferred to each higher order decade from the adjacent lower order decade for each ten steps of the lower order decade, after a gallon of fuel is delivered the decade counter sections 105, 104 and 103 would be stepped to their "2," "5" and "9" positions (i.e., the unit volume price established by the variator setting) and the counter 100 would continuously provide a count of the total cost of fuel delivered in accordance with the price established by the variator setting.

The counter 100 could for example be a suitable electromagnetic counter having counter wheels for displaying the cost amount of the fuel delivered. Alternatively the counter 100 could be an electronic counter, in which case suitable visual indicators 116 and decoder-driver circuits 118 for operating the indicators 116 may be provided to produce a visual readout of the three highest counter sections 104-106 for registering the total cost of the fuel delivered. Also if desired a suitable indicator 120 and corresponding decoder-driver circuit 121 could be provided as shown in broken lines in FIG. 2 for producing a tenth cent indication.

Referring to FIG. 3, another embodiment of the computing device of the present invention is shown employed in a fuel dispensing system of the type adapted for dispensing various blends of two separate fuel grades. In a conventional manner the two fuel grades are directed to the fuel delivery nozzle (not shown) via pumps 12, meters 16 and a proportioning valve 132, and the meter outputs are combined by a differential 134 to drive the computer input gearing 20 and suitable blend gearing 136. The outputs of the blend gearing 136 and one of the meters 16 are combined by a subtraction differential 138 to operate the proportioning valve 132 and to thereby establish the proportion of the two fuel grades in accordance with the setting of the blend gearing 136.

The computing device comprises a disc 31 and a plurality of output heads 32-34 for generating output pulse trains for operating a cost register 29 in the manner of the embodiment of FIGS. 1 and 2. Instead of a single bank 58 of selector switches 60 as shown in the embodiment of FIGS. 1 and 2, the computing device is shown comprising five banks 58 of selector switches 60, one bank for each available blend, and a master selector switch 146 for selectively energizing the switch banks 58. The selector switch 146 and the blend gearing 136 are operated by a blend selector knob 150 for selecting each available blend and corresponding switch bank 58. Corresponding switches 60 of the banks 58 are preferably connected in parallel as shown in FIG. 3 in which case suitable means such as diodes (not shown) would be provided for isolating the switches 60 for preventing feedback through inactive switches. Also, the selected switch bank 58 may be suitably indicated as by an index 160 mounted on a rack 162 and adapted to be positioned by the knob 150 through bevel gearing 164 and gear 166.

Referring now to FIG. 4, another embodiment of a computing device incorporating the present invention is shown having a pair of secondary or "adder" output heads 182, 184 for adding pulses to the "tenths" and "units" pulse trains respectively. A register 186 (which is like the register 29 excepting for the addition of a pair of adder input circuits 188, 190 connected to the output heads 182, 184 respectively) provides for registering the total cost of the fuel delivered in accordance with the settings of the primary output heads 32-34 and the "adder" output heads 182, 184.

The primary output heads 32-34 are controlled by a bank 58 of selector switches 60 in the manner of the embodiment of FIGS. 1 and 2 to establish a "base price," and the secondary output heads 182, 184 are selectively controlled to provide a "tenths" and "units" adder to the base price. The "tenths" adder head 182 may for example employ two lamps (not shown) associated with pulse actuator circles 54, 56 and with the lamps being connected to be energized together to provide for generating five pulses for each revolution of the variator disc 191. The "units" adder head 184 may for example be identical to the primary output head 33 and have four lamps which are selectively energized to provide for generating an adder pulse train of from zero to 15 pulses for each revolution of the disc 191.

The photoelectric pickup of the "tenths" adder head 182 is connected via the lead 192 and circuit 188 to combine its output pulse train with that of the primary "tenths" head 32, and the photoelectric pickup of the "units" adder head 184 is connected via the lead 194 and circuit 190 to combine its output pulse train with that of the primary "units" output head 33,

and for this reason the secondary output heads 182, 184 are angularly positioned with respect to the other output heads to generate noncoincident pulses. As a result, the total cost is computed on the basis of a unit volume price determined by adding the "tenths" and "units" adders provided by the adder heads 182, 184 respectively to the base price established by the primary output heads 32-34.

The embodiment of FIG. 4 has notable application in fuel-blending systems of the type described with reference to FIG. 3 and wherein the adder heads 182, 184 are operated for establishing the desired unit volume price for each of the available blends. For this purpose a suitable programmable selector switch mechanism 196 operated by the blend selector knob 150 is provided for programming the setting of the adder heads 182, 184 for each of the available fuel blends. Thus, for example, a unit volume price of 25.9 may be established by the switch bank 58 for the No. 1 blend, and the selector mechanism 196 may be programmed to provide an adder of 3.5, 7.0, 11.5 and 15.0 for the No. 2, 3, 4 and 5 blends respectively, thus establishing a unit volume price of 29.4 for blend No. 2; 32.9 for blend No. 3; 37.4 for blend No. 4; and 40.9 for blend No. 5.

The established unit volume price for the selected blend is posted by a price posting system 200 comprising a resettable decade counter 202 having decades 203-205 driven by the combined "tenths" and "units" pulse trains and the "tens" pulse train respectively. The decades 203-205 are interconnected to provide transfers from lower order to adjacent higher order decades and may have indicator wheels (not shown) for displaying the count of the counter. A suitable control circuit 212 is provided for selectively transferring the count of the counter 202 to a storage register 210, and for resetting the price posting counter 202 to zero. An auxiliary output head 214 operable by a pulse actuator circle 215 shown having a single light aperture 216 is connected to operate the control circuit 212 to transfer the count of the price posting counter 202 to the storage register 210 and to reset the counter 202 to zero. Thus, during each revolution of the disc 191 the counter 202 will be stepped to count from zero to the established unit volume price whereupon the price count will be transferred to the register 210 and the counter will be reset to zero. The storage register may have indicator wheels (not shown) for displaying the established unit volume price or price posting indicators 216 operated by suitable decoder-driver circuits 218.

Alternatively the control circuit 212 could provide for disconnecting the counter 212 after it has been stepped by the pulse trains generated by one revolution of the disc 191, in which case the price posting counter 202 would remain at the established unit volume price and the storage register 210 would be unnecessary.

Referring to FIG. 5 another embodiment of a computing device of the present invention is shown employed in a fuel blending system of the type shown in FIG. 3. The computing device employs two separate variators 26 which may be separately driven by the meters 16 as shown in full lines in FIG. 5, or, alternatively, one of the variators may be driven in accordance with the total amount of fuel delivered irrespective of the blend, by the output of the differential 134 as shown in broken lines in FIG. 5.

A separate bank 58 of price selector switches 60 is provided for setting the output heads 32-34 of each variator 26 and the pulse trains generated by corresponding output heads of the variators are combined by suitable parallel to series converters 230 to avoid dropping a coincident or overlapping pulse. Also, parallel to series converters 232 are provided for combining the output pulse trains and transfer pulses to the counter sections 102 and 103.

Thus, where the variator discs are individually driven by the respective meters 16 the variators 26 are adapted to the individually set by the respective banks 58 of selected switches to establish individual prices for each of the two grades of fuel and the register 234 will register the total cost of the fuel blend

delivered in accordance with the established prices for the two fuel grades.

Alternatively, where one of the variators is driven in accordance with the total amount of fuel delivered irrespective of the blend, the corresponding selector switch bank 58 would be set at a base price for the lower priced grade and the other variator would be set at the price differential of the two grades of fuel and be driven by the meter 16 for the higher priced grade. In this case three output heads 32-34 for the variator driven by the higher priced grade may be unnecessary to provide an adequate price differential range and for example a "units" head 33 providing a zero to 15 pulse range may be sufficient.

As will be apparent to persons skilled in the art, various modifications, adaptations and variations of the foregoing specific disclosure can be made without departing from the teachings of the present invention.

I claim:

1. In a computing device for a fluid-dispensing system having a counter operable for being indexed for counting the monetary amount of fluid dispensed and settable variator means for indexing the counter in accordance with the volume of fluid dispensed and multiple place unit volume pricing established by the setting of the variator means, the improvement wherein the variator means comprises a variator having a rotor adapted to be rotated in accordance with the volume of fluid dispensed, a plurality of pickups mounted for cooperation with the rotor, the rotor having a plurality of pulse actuators arranged in a plurality of coaxial circles and to operate the pickups for generating separate pulse trains of noncoincident pulses for indexing the counter, each pickup being mounted to be operated by each of the pulse actuators of each of a plurality of the pulse actuator circles, setting means for each pickup for selectively activating the corresponding pulse actuator circles for operating the pickup for establishing the number of pulses generated thereby for each revolution of the rotor for thereby setting the multiple place unit volume pricing, and connector means for connecting the pickups for indexing the counter in accordance with the number of pulses in each separate pulse train.

2. A computing device according to claim 1 wherein the pulse actuators are arranged in a plurality of generally concentric circles of different diameters.

3. A computing device according to claim 2 wherein the pickups extend generally radially of the concentric pulse actuator circles.

4. A computing device according to claim 1 wherein the counter comprises a plurality of counter sections of ascending order operable for counting the monetary amount of fluid dispensed, wherein the plurality of pickups correspond to different places respectively of the multiple place pricing, and wherein the pickups are connected by parallel entry to separate counter sections in accordance with the relative values of the respective places of the multiple place pricing.

5. A computing device according to claim 1 wherein the pulse actuators are arranged to provide at least one bank of pulse actuator circles with numbers of pulse actuators respectively in accordance with the geometric progression of $1a, 2a, 4a, \dots$

6. A computing device according to claim 1 wherein the pickups are photoelectric pickups.

7. A computing device according to claim 6 wherein the pulse actuators are light transmitters and wherein the setting means for the pickups comprise lamp means adapted for activating the light transmitters for operating the photoelectric pickups.

8. A computing device according to claim 7 wherein the lamp means comprises a bank of lamps associated with each photoelectric pickup and having a lamp for each light transmitter circle adapted for activation thereof for operating the pickup.

9. A computing device according to claim 8 wherein the rotor comprises a disc and wherein the light transmitters are

light apertures arranged on the disc in a plurality of concentric circles of different diameters.

10. A computing device according to claim 6 wherein each photoelectric pickup is a single photoelectric element.

11. A computing device according to claim 7 wherein the setting means for each pickup comprises lamp masking means for selectively unmasking the light transmitter circles for operating the pickup.

12. A computing device according to claim 8 wherein the setting means for each pickup comprises a switch operable for selectively energizing the lamps associated with the pickup.

13. A computing device according to claim 1 wherein the variator means comprises a pair of said variators having rotors connected to be rotated in accordance with the volume of fluid dispensed, and means for combining the pulse trains generated by each pair of corresponding pickups of the variators for producing a combined pulse train with noncoincident pulses for operating the counter.

14. In a computing device for a fluid-dispensing system for dispensing different blends of separate fluids and having a counter operable for counting the monetary amount of the fluid dispensed and settable variator means for operating the counter in accordance with the volume of fluid dispensed and multiple place unit volume pricing established by the setting of the variator means, the improvement wherein the variator means comprises a pair of rotors adapted to be differently rotated in accordance with the volume of fluid dispensed, first pickup means cooperable with one of the rotors for generating separate output pulse trains for different places of the multiple place pricing, second pickup means cooperable with the other rotor for generating at least one output pulse train for one of the places of the multiple place pricing, variator setting means for selectively establishing the number of pulses in each pulse train for each revolution of the rotor; and means for combining each pair of corresponding pulse trains generated by the first and second pickup means for producing a combined pulse train for operating the counter.

15. A computing device according to claim 14 wherein the second pickup means is cooperable with said other rotor for generating separate output pulse trains for said different places of the multiple place pricing, and wherein the pair of rotors are connected to be rotated in accordance with the volumes dispensed of the separate fluids respectively irrespective of the blend.

16. A computing device according to claim 14 wherein said one rotor is connected to be rotated in accordance with the volume of the blend dispensed and the other rotor is connected to be rotated in accordance with the volume dispensed of one of the separate fluids irrespective of the blend.

17. In a computing device for a fluid-dispensing system having a counter operable for being indexed for counting the monetary amount of fluid dispensed and settable variator means for indexing the counter in accordance with the volume of fluid dispensed and multiple place unit volume pricing established by the setting of the variator means, the improvement wherein the variator means comprises a rotor adapted to be rotated in accordance with the volume of fluid dispensed, at least one photoelectric cell mounted for cooperation with the rotor, the rotor having a plurality of pulse actuators arranged in a plurality of coaxial circles and to operate the photoelectric cell to generate a pulse train of spaced pulses for operating the counter, each photoelectric cell being mounted to be operated by each of the pulse actuators of each of the plurality of pulse actuator circles, and setting means for selectively activating the pulse actuator circles to operate the photoelectric cell for establishing the number of pulses generated thereby for each revolution of the rotor for thereby setting the multiple place unit volume pricing, and connector means for connecting each photoelectric cell for indexing the counter in accordance with the number of pulses in the respective pulse train.

18. A computing device according to claim 17 wherein the variator comprises a plurality of photoelectric cells for dif-

ferent places respectively of the multiple place pricing and setting means for each photoelectric cell.

19. In a computing device for a fluid-dispensing system having a counter with a plurality of counter sections of ascending order operable for counting the monetary amount of fluid dispensed and settable variator means for operating the counter in accordance with the volume of fluid dispensed and multiple place unit volume pricing established by the setting of the variator means, the improvement wherein the variator means comprises a rotor adapted to be rotated in accordance with the volume of fluid dispensed, base pickup means cooperable with the rotor for generating separate base pulse trains for different places respectively of the multiple place pricing, variator setting means for selectively establishing the number of pulses in each base pulse train for each revolution of the rotor, for establishing a multiple place unit volume base price, adder pickup means cooperable with the rotor for generating an adder pulse train for at least one place of the multiple place pricing, adder setting means for selectively establishing the number of pulses in the adder pulse train for each revolution of the rotor for providing an adder to the base price, and means for connecting the base pickup means and adder pickup means for operating the counter with the base and adder pulse trains in accordance with the relative values of the respective places of the multiple place pricing.

20. In a computing device for computing the product of an amount proportional to a rotational input and a multiplier comprising a unitary rotor, a rotary input for rotating the rotor, the rotor having a plurality of light apertures arranged in a plurality of at least four spaced circles coaxial with the rotor to provide a plurality of separate light aperture sets, a photoelectric pickup with a single photoelectric cell mounted for cooperation with the plurality of light aperture sets to be operated by each light aperture of each light aperture set to generate a corresponding train of spaced electrical pulses, and setting means operable for selectively activating and deactivating the light aperture sets to operate the photoelectric cell for establishing the number of pulses generated thereby for each revolution of the rotor, and counting means connected to be indexed in accordance with the number of pulses in the electrical pulse train generated by the photoelectric pickup for counting the product of an amount proportional to the rotation of the rotary input and a multiplier established by the operation of the setting means.

21. A computing device according to claim 20 wherein the rotor is a rotary disc and said plurality of light apertures are arranged in a plurality of radially spaced circles.

22. A computing device according to claim 21 wherein the setting means comprises control light apertures for activating selected aperture sets and masking means for masking the remaining light aperture sets.

23. A computing device according to claim 21 wherein there are four light aperture sets with one, two, four and eight light apertures respectively.

24. A computing device according to claim 21 wherein the setting means comprises a bank of selectively operable lamps for the plurality of light aperture sets respectively.

25. A computing device according to claim 24 wherein the setting means comprises binary switch means for selectively energizing the lamps.

26. In a computing device for a fluid-dispensing system having a counter operable for counting the monetary amount of fluid dispensed and settable variator means for operating the counter in accordance with the volume of fluid dispensed and multiple place unit volume pricing established by the setting of the variator means, the improvement wherein the variator means comprises a variator having a rotor adapted to be rotated in accordance with the volume of fluid dispensed, a plurality of photoelectric pickups mounted for cooperation with the rotor, the rotor having a plurality of light transmitters arranged in a plurality of coaxial circles and to operate the photoelectric pickups for generating separate pulse trains of noncoincident pulses for operating the counter, and setting

means for each pickup for selectively activating light transmitter circles for operating the pickup for establishing the number of pulses generated thereby for each revolution of the rotor, the setting means comprising a bank of lamps associated with each photoelectric pickup and having a lamp for each light transmitter circle adapted for activation thereof for operating the pickup, and a switch operable for selectively energizing the lamps associated with the pickup having an angularly settable number wheel and a binary switch settable with the wheel to provide a binary signal corresponding to the angular position of the wheel for selectively energizing the lamps.

27. In a computing device for a fluid-dispensing system having a counter operable for counting the monetary amount of fluid dispensed and settable variator means for operating the counter in accordance with the volume of fluid dispensed and multiple place unit volume pricing established by the setting of the variator means, the improvement wherein the variator means comprises a variator having a rotor adapted to be rotated in accordance with the volume of fluid dispensed, a plurality of photoelectric pickups mounted for cooperation with the rotor, the rotor having a plurality of light transmitters arranged in a plurality of coaxial circles and to operate the photoelectric pickups for generating separate pulse trains of noncoincident pulses for operating the counter, and setting means for each pickup for selectively activating light transmitter circles operating the pickup for establishing the number of pulses generated thereby for each revolution of the rotor, the setting means comprising a bank of lamps associated with each photoelectric pickup and having a lamp for each light transmitter circle adapted for activation thereof for operating the pickup, and a plurality of switch banks each comprising a switch for each bank of lamps operable for selectively energizing the lamps thereof, and a selector for individually selecting

the switch banks for operating the banks of lamps.

28. In a computing device for a fluid-dispensing system having a counter operable for counting the monetary amount of fluid dispensed and settable variator means for operating the counter in accordance with the volumetric amount of fluid dispensed and unit volume pricing established by the setting of the variator means, the improvement wherein the variator means comprises a rotor adapted to be rotated in accordance with the volumetric amount of fluid dispensed, pickup means cooperable with the rotor for generating separate output pulse trains for different places respectively of the multiple place pricing, setting means for selectively setting the number of pulses in each output pulse train for each evolution of the rotor for establishing a multiple place price, means for connecting the pickup means to the counter for operating the counter with the pulse trains in accordance with the relative values of the respective places of the multiple place pricing, and price posting means connected for operation by the separate pulse trains in accordance with the relative values of the respective places of the multiple place pricing for posting the multiple place price established by the setting means, the price posting means comprising an auxiliary pickup mounted for cooperation with the rotor for generating at least one pulse for each revolution of the rotor, and a price posting counter operative by the separate pulse trains in accordance with the relative values of the respective places of the multiple place pricing for establishing a count according to the established multiple place price.

29. A counting device according to claim 28 wherein the price posting means comprises indicator means for indicating the established multiple place price and means for transferring the count of the price posting counter to the indicator means for indicating the established multiple place price.

* * * * *

40

45

50

55

60

65

70

75

UNITED STATES PATENT OFFICE
CERTIFICATE OF CORRECTION

Patent No. 3,633,000 Dated January 4, 1972

Inventor(s) JOHN H. BICKFORD

It is certified that error appears in the above-identified patent and that said Letters Patent are hereby corrected as shown below:

Figure 1 of the patent is substituted for the illustrative drawing on the cover sheet.

Signed and sealed this 29th day of May 1973.

(SEAL)
Attest:

EDWARD M. FLETCHER, JR.
Attesting Officer

ROBERT GOTTSCHALK
Commissioner of Patents