

⑫ **EUROPEAN PATENT APPLICATION**

⑰ Application number: 86115415.1

⑤① Int. Cl.⁴: **H 01 B 7/08**

⑱ Date of filing: 06.11.86

⑳ Priority: 18.11.85 US 798997

④③ Date of publication of application:
01.07.87 Bulletin 87/27

⑧④ Designated Contracting States:
DE ES FR GB IT

⑦① Applicant: **COOPER INDUSTRIES, INC.**
First City Tower Suite 4000 P.O. Box 4446
Houston Texas 77210(US)

⑦② Inventor: **Cox, Albert Ray**
689 Centerville Road North
Centerville Indiana 47330(US)

⑦② Inventor: **Biegon, Robert John**
1217 Ridgeway Avenue
Aurora Illinois 60506(US)

⑦② Inventor: **Men, Grigory**
1384 Queensgreen Circle
Naperville, Illinois 60540(US)

⑦② Inventor: **Turner, Lester Thomas**
P.O. Box 171
Tompkinsville Kentucky 42167(US)

⑦④ Representative: **Patentanwälte Grünecker, Kinkeldey,
Stockmair & Partner**
Maximilianstrasse 58
D-8000 München 22(DE)

⑤④ **Mass terminable flat cable and cable assembly incorporating the cable.**

⑤⑦ A flat cable for use with a mass termination connector having a plurality of regularly spaced terminal elements. The flat cable includes a laminated carrier film and a plurality of discrete conductors held in regularly spaced parallel relationship by the carrier film to match the terminal element spacing of the connector. Each conductor has an insulating jacket made of a thermoplastic material. The carrier film includes an attachment layer of thermoplastic insulation having a melting temperature similar to that of the jacket material, and a dimensional stabilization layer made of an insulative material having a melting temperature higher than those of the attachment layer and the jacket material and displaying dimensional stability at the melting temperatures of the attachment layer and jacket material. The jackets of the conductor are fused to the attachment layer, and the attachment layer is held by the stabilization layer. The carrier film can be longitudinally discontinuous to form first cable sections where the conductors are held parallel for ease of termination, and second cable sections where the conductors are not held to increase flexibility and reduce weight. The cable can also be formed into a round configuration to provide advantages during routing. A method of manufacturing this cable is also disclosed.

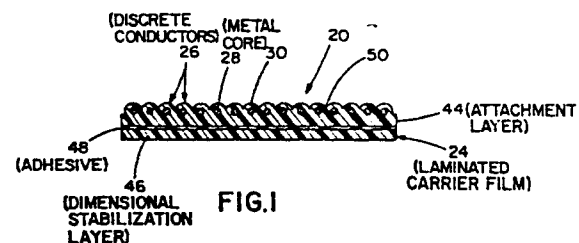

MASS TERMINABLE FLAT CABLE AND CABLE
ASSEMBLY INCORPORATING THE CABLE

The present invention relates to electrical wiring components and, more specifically, to a cable assembly incorporating a flat cable adapted for use with mass termination, insulation displacement connectors.

Background of the Invention

Mass termination, insulation displacement connectors have come into increasing commercial prominence because of the significant savings in time and labor they offer compared to stripping and individually terminating each conductor using a crimp terminal. These connectors have an insulative housing body holding a number of regularly spaced terminal elements having slotted plates terminating in sharpened free ends extending beyond a surface of the body. The conductors also include covers having recesses in a facing surface for receiving the free ends of the plates. After the insulated conductors are aligned with their corresponding slotted plates, relative closing of the housing body and cover results in displacement of the insulation with the conductor cores contacting the metallic plates. For further information regarding the operation and structure of such mass termination connectors, reference may be made to U.S. Patent Nos. 4,458,967 and 3,912,354.

The most efficient form of conductors for use with such connectors is the flat cable in which conductors, running parallel and spaced to match the spacing of the terminal elements in the connector, are held by a layer of insulation. The use of a flat cable avoids running the conductors one at a time and holding them in position for termination. The flat cable can be used for either a daisy chain connection (where the

connector is applied intermediate the cable ends) or an end connection. The sharpened ends of the slotted plates pierce the web material between the conductors in the flat cable as the body and cover close so slitting
5 of the cable between conductors is not required.

While flat cables offer many advantages with respect to efficiency in termination, they present difficulties during routing. Flat cables have certain dimensions larger than comparable round cables, the flat
10 cables do not bend as easily, they are more susceptible to damage during routing, and the continuous presence of the layer of insulation holding the discrete conductors may result in somewhat increased weight of a flat cable. Additionally, a flat cable is usually more
15 susceptible to electrical cross talk than a comparable round cable.

There are several methods for manufacturing flat cable. In one method, the insulation is extruded about parallel, coplanar conductors. In another, two
20 layers of insulation are bonded together with the conductors held in parallel, coplanar relationship. Some of these methods require the use of large expensive manufacturing equipment. One simpler manufacturing method has been proposed wherein individual conductors,
25 each having a thermoplastic jacket, are positioned on a layer of the same material as that used in the jackets. Upon raising the temperature to the melting point of the insulation, the jackets and layer will fuse, forming a flat cable. Unfortunately, the most commonly used
30 insulating materials, such as polyvinyl chloride, have poor dimensioned stability, particularly when the flat cable is subjected to varying temperatures.

A method of forming flat cable using conductor modules has also been suggested. In this method, pairs
35 of conductors are formed into modules by applying a jacket of insulation about them. The modules are fed in edge-to-edge relationship between two webs of polyester

material precoated with a hot-melt adhesive on their facing surfaces. This assembly is then subjected to heating and the application of pressure to form the final flat cable assembly. For additional information concerning this flat cable and its method of manufacture, reference may be made to U.S. Patent No. 4,468,089.

Summary of the Invention

Among the several aspects of the present invention may be noted the provision of an improved flat cable adapted for use with mass termination, insulation displacement connectors. The cable has greater strength, increased dimensional stability over a wide temperature range, lighter weight, and smaller finished cable thickness than conventional flat cables which employ a carrier film of the same insulating material as the jacket on the conductor cores. A cable embodying features of the present invention can be reconfigured from substantially round to flat, and has reduced electrical cross talk. The cable of the present invention is reliable in use, has long service life and is simple and economical to manufacture. Other aspects and features of the present flat cable will be, in part, apparent and, in part, pointed out hereinafter in the following specification and in the accompanying claims and drawings.

Briefly, the flat cable of the present invention includes a laminated carrier film and a plurality of discrete conductors held in regularly spaced parallel relationship by the carrier film to match the terminal elements spacing of the connector. Each conductor has an insulative jacket made of a thermoplastic material. The carrier film includes an attachment layer of thermoplastic insulation having a melting temperature similar to that of the jacket material. The carrier film also includes a dimensional stabilization layer holding the attachment layer and

made of an insulative material having a melting
temperature higher than those of the attachment layer
and the jacket material and displaying dimensional
stability at the melting temperatures of the attachment
5 layer and the jacket material. The jackets of the
conductors are fused to the attachment layer. The
carrier film can be longitudinally discontinuous to form
first cable sections where the conductors are held
parallel for ease of termination and second cable
10 sections where the conductors are not held to increase
flexibility and reduce weight. The cable can be formed
into a round configuration to provide advantages during
routing.

As a method of manufacturing a flat cable, the
15 present invention includes several steps: 1) The
jacketed conductors are positioned against the
attachment layer so that the spacing of the conductors
matches that of the terminal elements in the connector.
2) The temperatures of the conductors jackets and the
20 attachment layer are raised until the jackets and the
attachment layers fuse. 3) The conductors have their
positions maintained on the attachment layer until the
temperatures of the jackets and the attachment layer
drop sufficiently so that the jackets are fixed.

25 Brief Description of the Drawings

FIG. 1 is an end view of the mass terminable
flat cable of the present invention;

FIG. 2 is an exploded perspective view showing
a mass termination insulation displacement connector
30 usable with the cable of FIG. 1;

FIG. 3 is a simplified diagrammatic
representation of a method of manufacturing the cable of
FIG. 1.

FIG. 4 is a plan view of a cable assembly
35 incorporating an alternative embodiment of a cable
embodying various features of the present invention
wherein the cable can be reconfigured from a round

configuration to a flat configuration by removal of an outer protective sheath, and wherein first cable sections in which conductors run parallel and are held by a carrier film are spaced by second cable sections which do not have the carrier film and in which the conductors are paired and twisted;

FIG. 5 illustrates the cable assembly of FIG. 4 with certain components removed and with the cable in its round configuration throughout its length;

10 FIG. 6 is a cross-sectional view taken generally along line 6--6 of FIG. 5 through a first cable section in which the cable is spiralled around a central strength member;

15 FIG. 7 is a cross-sectional view taken generally along line 7--7 of FIG. 5 through a second cable section; and

FIG. 8 is a cross-sectional view of an alternative embodiment of the cable of FIG. 4 wherein the flat cable is folded instead of spiralled.

20 Corresponding reference numbers indicate corresponding components throughout the several views of the drawings.

Description of the Preferred Embodiment

25 Referring now to the drawings, a flat cable of the present invention adapted for use with a mass termination, insulation displacement connector 22 (shown in FIG. 2), is generally indicated by reference numeral 20. The flat cable 20 includes a laminated carrier film 24 and a plurality of discrete conductors 26 held in 30 regularly spaced, parallel relationship by the carrier film. Each conductor 26 includes a metallic, i.e., copper, core 28 and an insulating jacket 30 about the core. While the particular flat cable illustrated is intended for carrying electrical signals and has the 35 cores on .050 inch centers, it will be appreciated that the flat cable 20 of the present invention can be made in larger sizes for use in supplying electrical power to various electrical components.

The mass termination connector 22 shown in FIG. 2 is of the high terminal density, signal conductor type and includes an insulative body 32 having two rows of terminal element cavities. A terminal element 33 is
5 disposed in each cavity with elements in each row having a .100 inch pitch. Adjacent terminal elements in each row are staggered so that every other conductor 26 is terminated by elements in one row while the remaining conductors are terminated by the elements in the other
10 row. Each terminal element includes a slotted plate 34 extending beyond a surface 35 of the body with the plate terminating in sharpened ends for piercing the web material of the flat cable between the conductors. The plate edges defining the slot function to displace the
15 conductor jacket material so that by forcing a conductor 26 into a slotted plate 34, the conductor core 28 is engaged by the metallic plate to establish an electrical circuit. The connector 22 also includes a cover 36 held in alignment with the body 32 by means of pins 38. The
20 cover, also formed of insulating material, includes a facing surface 40 having pockets 42 for locating the flat cable conductors 26 with respect to the terminal elements 33, and a recess 43 for receiving the free ends of the slotted plates 34. Thus after the flat cable 20
25 is positioned between the cover 36 and the body 32, relative closing of the two results in mass termination of the conductors 26 of the flat cable 20.

Referring to FIG. 1, the carrier film 24 includes an attachment layer 44 of a thermoplastic
30 insulation having a melting temperature similar to that of the jacket material 30, and a dimensional stabilization layer 46 made of an insulating material having a melting temperature higher than those of the attachment layer and the jacket material and displaying
35 dimensional stability at the melting temperatures of the attachment layer and the jacket material. The jackets 30 of the conductors 26 are fused to the attachment

layer 44 and the attachment layer is held by the stabilization layer 46 preferably by bonding them together with an adhesive 48, or the attachment layer and the stabilization layer may themselves be fused.

5 Also preferably the attachment layer 44 and the conductor jackets 30 are made of the same insulating material. Among the several combinations of insulating materials are the following: polyvinyl chloride jackets and attachment layer with polyester stabilization layer; 10 fluorinated ethylene-propylene jackets and attachment layer with tetrafluoroethylene stabilization layer; polyethylene jackets and attachment layer with polyester stabilization layer; and polypropylene jackets and attachment layer with polyester stabilization layer.

15 With respect to the first combination, polyester offers a greater strength to weight ratio than polyvinyl chloride. Also polyester has better dimensional stability over a wide range of thermal and environmental conditions. The other combinations offer 20 similar characteristics. Thus the cable 20 can have greater strength, better temperature stability, smaller thickness and lighter weight than a conventional flat cable which uses a carrier layer of the same insulating material as the conductor jackets. Additionally, the 25 polyester stabilization layer 46 serves a strain relief function when mass termination connectors including strain clips are employed. Upon tensioning of the flat cable between connectors, the polyester layer resists extension of the jackets and the metallic conductor 30 cores.

It will also be appreciated that the flat cable 20 has a side 50 which is undulating, with the undulations formed by the individual jackets 30. These undulations are received by the pockets 42 in the 35 connector cover 36 to properly locate the various cores 28 in alignment with their corresponding slotted plates 34. This is advantageous over a flat cable having flat

sides because the connector does not have to be provided with alignment stops at the sides of the cover and/or body to position the flat cable in position for termination.

5 As shown diagrammatically in FIG. 3, the flat cable 20 of the present invention is relatively simple to manufacture using a continuous process. At a feed station 52 are positioned a roll 54 of the carrier film 24 and a number of spools 56 of the conductors 26. The
10 carrier film and the plurality of the conductors are received by a positioning die 58 which aligns the various conductors 26 in regularly spaced, parallel relationship on the attachment layer 44 of the carrier film. The die has conductor-receiving passageways which
15 decrease in dimension from the die entrance side to its exit side so that upon exit of the cable components, the conductors are held firmly against the attachment layer. The film and conductors next pass through a
20 heating zone 60 where the temperatures of the jacket material and the attachment layer are raised sufficiently that the conductors and attachment layer fuse. Next downstream is a cooling zone where another die 62 functions firmly to hold the conductors against the attachment layer until the jackets are fixed onto
25 the attachment layer. Finally, the completed flat cable 20 is wound on a take up reel 64. The above description assumes that the formation of the carrier layer has been completed. The carrier layer 24 can also be formed as a preliminary operation in this
30 manufacturing process by including an upstream station where the attachment layer and stabilization layer are bonded.

 As a method of manufacturing a flat cable for use with a mass termination connector 22 having regularly
35 spaced terminal elements 33, the present invention includes the following steps:

1) The jacketed conductors 26 are positioned in parallel spaced relationship against the carrier film 24 so that the conductor engage the attachment layer 44 with the spacing between the conductors matching that of the terminal elements in the connector.

2) The temperatures of the conductor jackets 30 and the attachment layer 44 are raised so that the jackets and the attachment layer fuse. However, the temperature of the stabilization layer 46 remains below its melting temperature.

3) The positioning of the conductors is maintained until the temperatures of the jackets and the attachment layer drop sufficiently so that the jackets become fixed on the attachment layer.

It will be appreciated that the particular construction of the flat cable 20 allows the use of different insulating materials for the jackets 30 of the conductors in the same manufacturing process without requiring modification of expensive equipment components. This is because of the great flexibility offered by cable 20. If a particular insulation is required for the conductor jackets, only the attachment layer coating on the polyester film stabilization layer need be changed to match the jacket material used in the conductors 26.

While the flat cable is shown with the conductors running parallel throughout the length of the cable, the cable could alternatively have sections wherein adjacent conductors form twisted pairs with those sections spaced by other sections wherein the conductors run parallel to one another.

Referring now to FIGS. 4-8, a cable assembly 66 is shown which includes an alternative embodiment 20A of the flat cable of the present invention. Components of the flat cable 20A corresponding to components of the flat cable 20 are indicated by the reference numeral applied to the component of the flat cable 20 with the

addition of the suffix "A". As shown in FIG. 4, the flat cable 20A is longitudinally divided into a plurality of spaced first cable sections 68 in which the conductors 26A are held in regularly spaced, parallel relationship by carrier film 24A by means of the attachment layer 44A being fused with the conductor jackets, and a plurality of second cable sections 70 wherein the conductors are not held. The conductors in the second sections 70 are preferably disposed in twisted pairs, as shown in FIGS. 4 and 5, or the conductors may be in an unpaired configuration. A second cable section 70 spaces each adjacent pair of first cable sections 68. The first cable sections 68 are preferably regularly spaced and are somewhat shorter than the second cable sections 70. The first cable sections are used for termination of the conductor cores 28A by the insulation displacement connectors 22 because it is at the first cable sections where the conductors are held in a regularly spaced array having centers matching those of the terminal elements 33 of the connector. On the other hand, the presence of the second cable sections 70 with the loose twisted pairs provides greater flexibility, lighter weight, and improves the electrical characteristics of the cable in that cross talk is reduced.

The flat cable 20A, when part of the cable assembly 66, is deformed into a non-flat and preferably substantially circular configuration. The cable assembly 66 includes an outer jacket 72 constituting means disposed about the periphery of the cable 20A for holding the cable in its preferably circular cross-sectional configuration. The outer jacket is formed of a tough, abrasion resistant thermoplastic material and the outer surface of the jacket 72 carries spaced indicia 74 (such as a circular stripes) to locate the presence of the first cable sections 68. Thus, the user can easily find a first cable section, strip the

outer jacket therefrom and apply a connector 22 after returning the cable section to its flat configuration. The round configuration of the cable 20A when held in the cable assembly 66 provides many advantages when the cable assembly is routed. A round configuration has smaller dimensions, is more flexible in certain directions (a flat cable configuration has restricted bending in the plane of the flat cable) and is more resistant to damage during routing, for example, during pulling of the cable assembly through a conduit.

The flat cable 20A can be deformed from its flat, as-manufactured configuration to the substantially round configuration by spiralling, as shown in FIG. 6, or by folding, as shown in FIG. 8. A central strength member 76, formed by a fiber or steel stranded rope, may be provided. The spiralled configuration offers certain advantages in that the deformed cable more closely resembles a round configuration without extensive use of fillers with the cable 20A inside the outer jacket 72, and the cable 20A is not required to undergo severe bending. On the other hand, the accordion folded cable shown in FIG. 8 can quickly be returned to its flat configuration by pulling apart the lateral sides of the exposed first cable section.

Optionally, as shown in FIG. 5, the cable assembly 66 can include a metallic shield encompassing the deformed flat cable 20A. The shield comprises a foil 78 which might be on Mylar (Mylar is a registered trademark of Dupont for polyester film) and/or a metallic braid 80. Optimum shielding is achieved using the foil 78 disposed under the braid 80 and in contact therewith, the use of the braid over the foil results in the lowest radio frequency leakage and lowest susceptibility to electrical noise. The braid functions to limit penetration of low frequency noise while the presence of the foil limits high frequency noise penetration.

In view of the above, it will be seen that the several objects of the invention are achieved and other advantageous results attained.

As various changes could be made without
5 departing from the scope of the invention, it is intended that all matter contained in the above description shall be interpreted as illustrative and not in a limiting sense.

CLAIMS:

1. A flat cable for use with a mass
termination connector having a plurality of regularly
spaced terminal elements, said cable comprising: a
plurality of discrete conductors extending throughout
5 the length of said cable, each conductor having an
insulative jacket made of a thermoplastic material; said
cable having a plurality of spaced first cable sections
in which said conductors are held in regularly spaced
parallel relationship, said cable further having a
10 plurality of spaced second cable sections in which said
conductors are not held in regularly spaced parallel
relationship, with adjacent first cable sections being
spaced by a second cable section; each first cable
section comprising a laminated carrier film holding said
15 conductors, said carrier film including an attachment
layer of thermoplastic insulation having a melting
temperature similar to that of the jacket material, and
a dimensional stabilization layer made of an insulative
material having a melting temperature higher than those
20 of the attachment layer and the jacket material and
displaying dimensional stability at the melting
temperatures of the attachment layer and jacket
material, the jackets of said conductors being fused to
said attachment layer and said attachment layer being
25 held by said stabilization layer.

2. A flat cable as set forth in Claim 1
wherein in said second cable sections said conductors
are arranged in twisted pairs.

3. A flat cable as set forth in Claim 1
30 wherein the conductor jackets and the attachment layer
are made of the same material.

4. A flat cable as set forth in Claim 1
wherein the said attachment layer is formed of polyvinyl
chloride.

5. A flat cable as set forth in Claim 1 wherein
35 said stabilization layer is made of a polyester film.

6. A flat cable as set forth in Claim 10226779 wherein each of said first cable sections has a substantially flat side and an opposite undulating side with each undulation formed by one of the jacketed
5 conductors.

7. A flat cable as set forth in Claim 1 wherein said carrier film comprises an adhesive bonding said attachment layer to said stabilization layer.

8. A cable assembly for use with a mass
10 termination connector having a plurality of regularly spaced terminal elements, said cable assembly comprising: a flat cable deformed from its flat, as-manufactured configuration into a non-flat configuration; and holding means disposed about the
15 periphery of said cable holding said cable in said non-flat configuration whereby removal of the holding means allows said cable substantially to return to its flat configuration, said cable in its as-manufactured configuration comprising: a plurality of discrete
20 conductors extending throughout the length of said cable, each conductor having an insulative jacket made of a thermoplastic material; said cable having a plurality of spaced first cable sections in which said conductors are held in regularly spaced parallel
25 relationship, said cable further having a plurality of spaced second cable sections in which said conductors are not held in regularly spaced parallel relationship, with adjacent first cable sections being spaced by a second cable section; each first cable section
30 comprising a laminated carrier film holding said conductors, said carrier film including an attachment layer of thermoplastic insulation having a melting temperature similar to that of the jacket material, and a dimensional stabilization layer made of an insulative
35 material having a melting temperature higher than those of the attachment layer and the jacket material and displaying dimensional stability at the melting

temperatures of the attachment layer and jacket material, the jackets of said conductors being fused to said attachment layer and said attachment layer being held by said stabilization layer. 0226779

5 9. A cable assembly as set forth in Claim 8 wherein said non-flat configuration is substantially circular.

10 10. A cable assembly as set forth in Claim 8 wherein the holding means comprises an outer jacket formed of an abrasion resistant thermoplastic material.

11. A cable assembly as set forth in Claim 10 wherein said jacket has spaced indicia on its outside surface locating said first cable sections.

15 12. A cable assembly as set forth in Claim 8 wherein said conductors are arranged in twisted pairs in said second cable sections.

13. A cable assembly as set forth in Claim 8 further including a central strength member.

20 14. A cable assembly as set forth in Claim 8 wherein said flat cable is spiralled to form said non-flat configuration.

15 15. A cable assembly as set forth in Claim 8 wherein said flat cable is folded to form said non-flat configuration.

25 16. A cable assembly as set forth in Claim 8 further comprising a metallic shield surrounding said cable.

17. A cable assembly as set forth in Claim 16 wherein said shield is a foil.

30 18. A cable assembly as set forth in Claim 16 wherein said shield is a braid.

1/2

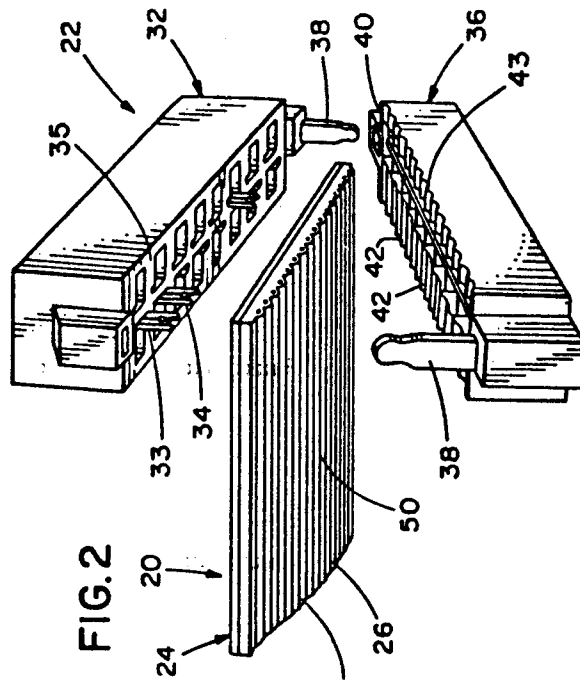

FIG. 2

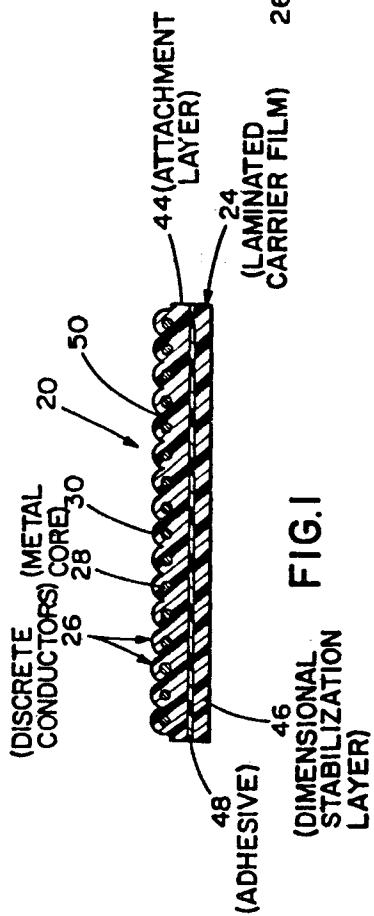

FIG. 1

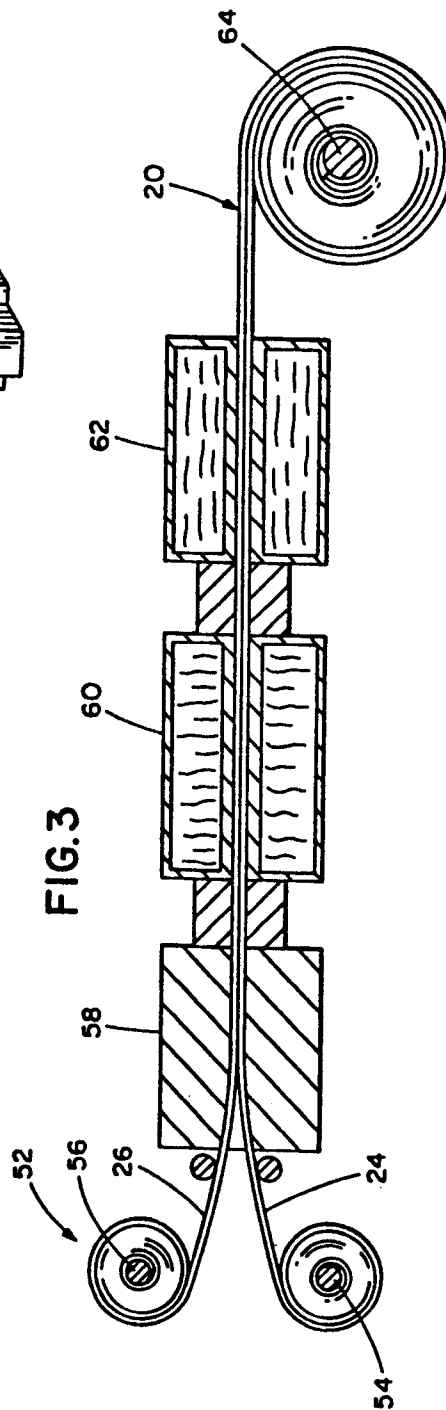

FIG. 3

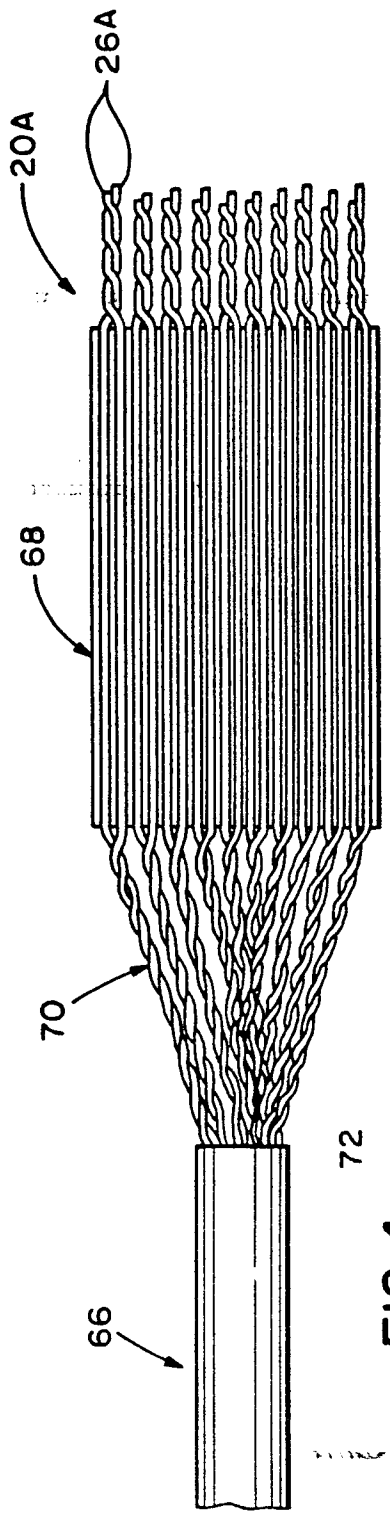

FIG. 4

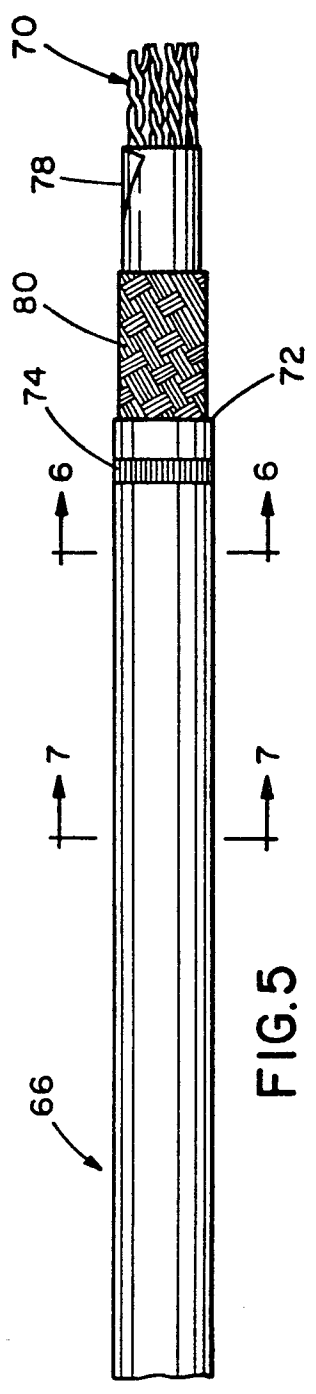

FIG. 5

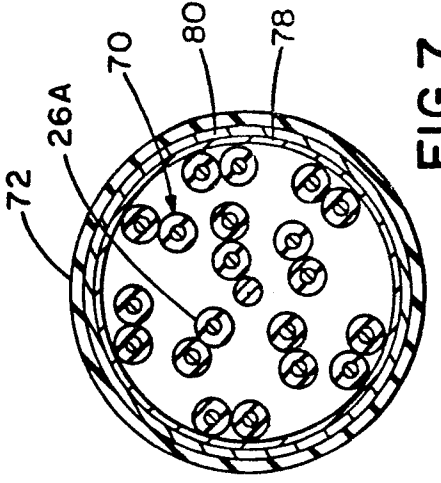

FIG. 7

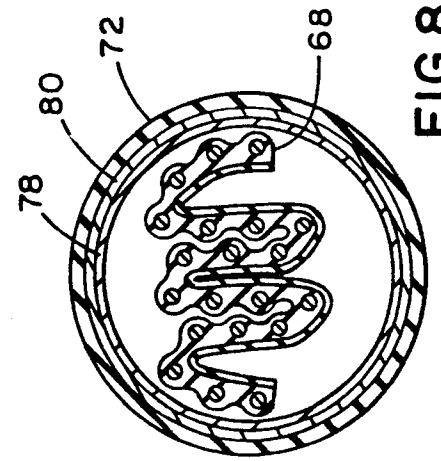

FIG. 8

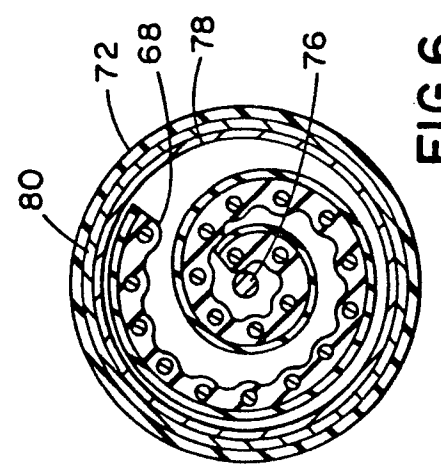

FIG. 6