

Dec. 7, 1926.

1,610,020

J. S. McILHENNY

GAS SHUT-OFF VALVE

Filed August 15, 1925

2 Sheets-Sheet 1

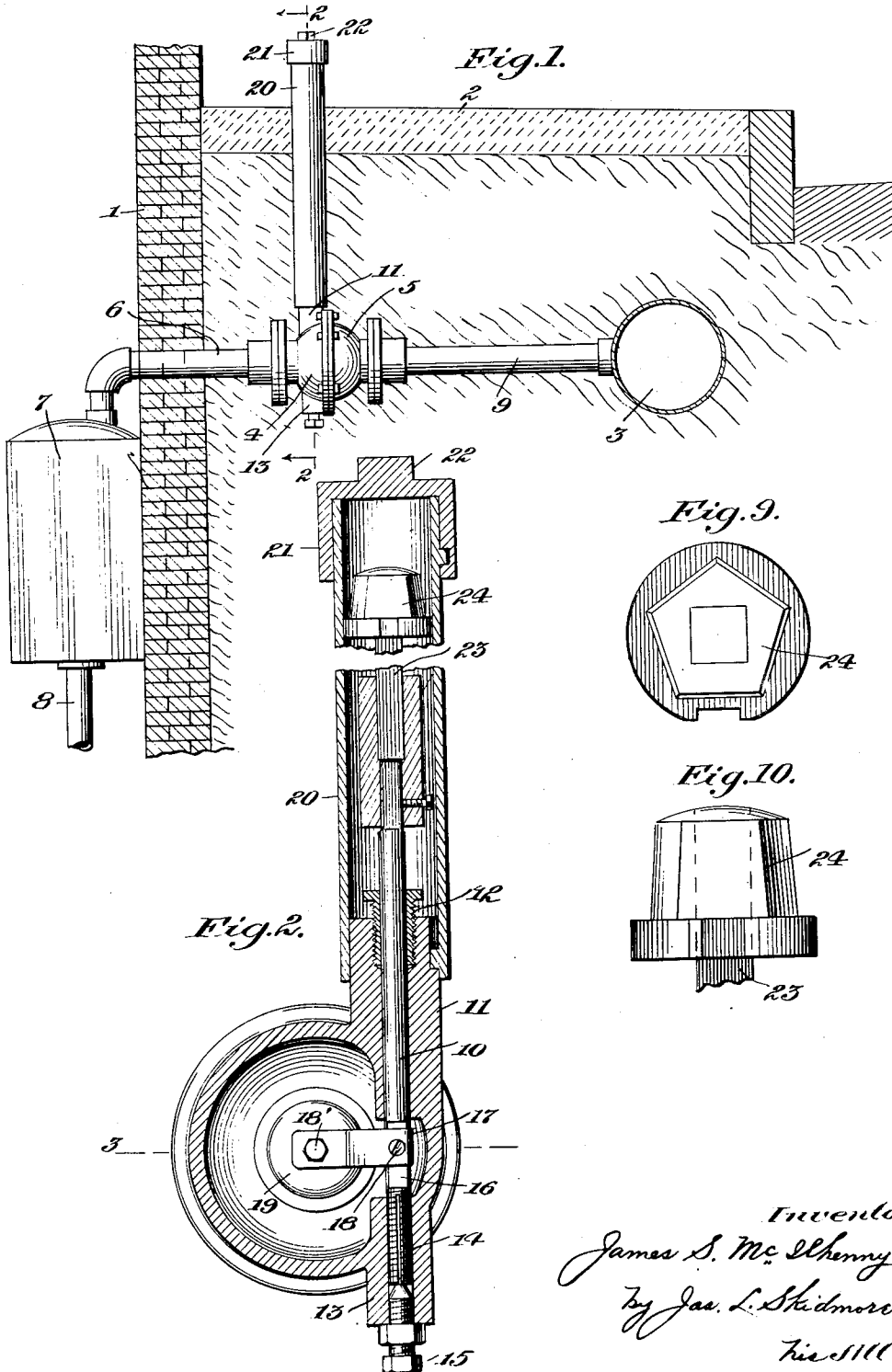

Inventor:  
James S. McIlhenny  
By Jas. L. Skidmore  
Tie 1111'4.

Dec. 7, 1926.

1,610,020

J. S. McILHENNY

GAS SHUT-OFF VALVE

Filed August 15, 1925

2 Sheets-Sheet 2

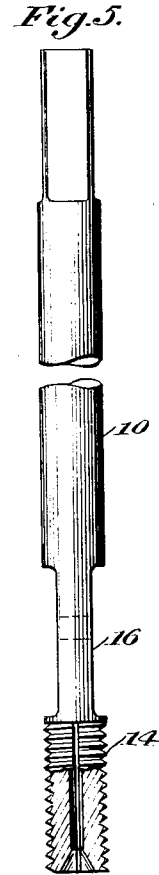
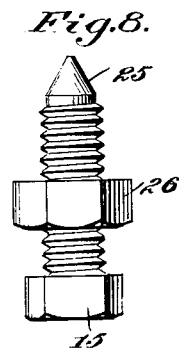
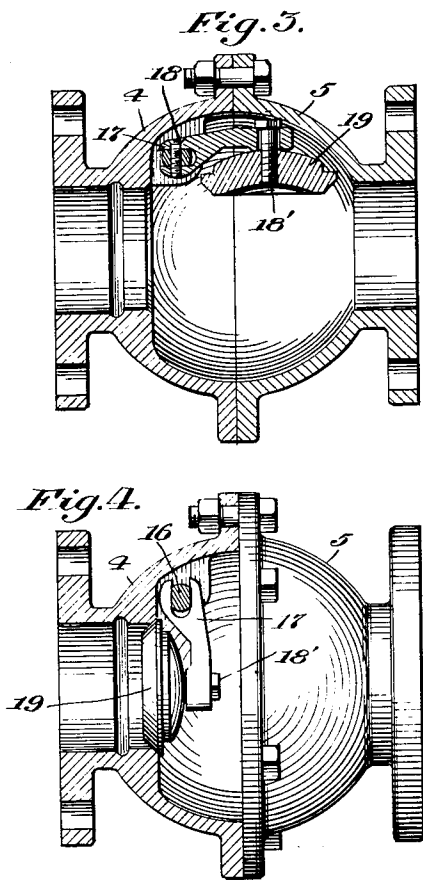

Inventor:  
James S. McIlhenney  
by Jas. L. Schildmoss  
his Atty.

Patented Dec. 7, 1926.

1,610,020

# UNITED STATES PATENT OFFICE.

JAMES S. McILHENNY, OF WASHINGTON, DISTRICT OF COLUMBIA.

## GAS SHUT-OFF VALVE.

Application filed August 15, 1925. Serial No. 50,523.

This invention pertains to means available in emergency such as in case of conflagration or other calamity in a building for safely and securely shutting off the connection between the street gas main and the pipe for the distribution of the gas to the consuming points in and throughout the building.

The prime object of the invention is to provide simple, durable, economical, practical and thoroughly efficient means for safely and reliably shutting off the gas from the main supply to the distributing pipes within buildings of all types of construction.

Another object of this invention is to provide a valve movably mounted within the valve casing located between the outer wall of the building and the main supply, said valve having operating connections leading therefrom to a suitable point above the grade, and preferably adjacent to the outer wall of the building whereby a fireman or other authorized person in possession of the standard wrench required may secure an immediate operation of the device for shutting off the gas.

Another object of the invention is to so construct the valve operating means that when the valve is rocked into the closed position it will be automatically retained in such closed position, and locked against accidental opening thereof.

The foregoing and such other objects as may appear from the ensuing description are accomplished by the construction, location, arrangement and combination of the several parts hereinafter more fully described, illustrated in the accompanying drawings, and more particularly pointed out in the claims appended hereto, it being understood that slight changes in the precise proportions and minor details of construction may be resorted to without departing from the spirit or sacrificing any of the advantages of the invention.

In the accompanying drawings forming a part of this specification, it will be seen that:

Figure 1 is a side elevation of the means embodying my invention,

Figure 2 is a sectional elevation taken in the plane of the dotted lines 2—2, Fig. 1, looking in the direction of the arrows,

Figure 3 is a central horizontal section through the valve casing, taken in the plane

of the dotted lines 3—3, Fig. 2, showing the valve in its open position,

Figure 4 is a similar view partly in section showing the valve in its closed position,

Figure 5 is an elevation of the valve operating stem removed showing one end portion of the stem in section,

Figure 6 is an end view of the valve stem,

Figure 7 designates an end view of a slightly modified form of valve stem,

Figure 8 is an elevation of the adjustable valve stem retaining and locking means removed,

Figure 9 is a plan of the top of the valve stem operating means, and

Figure 10 is a side elevation of the same.

In the embodiment of my invention as illustrated it will be seen that the numeral 1 indicates a portion of a vertical front wall of a building, 2 the grade line outside of the building, and 3 the usual gas supply main. Suitably disposed below the grade line, preferably just outside the building wall, is a valve casing preferably consisting of two cast iron sections 4 and 5, rigidly and firmly secured together in any desirable manner at their meeting ends, and connected to one end of said valve casing is a gas inlet pipe 6 which is passed through the wall and connected to one end of the usual gas meter 7, while to the other end of the meter is connected one end of the gas distribution pipe 8, and to the opposite end of the valve casing is suitably secured a pipe 9 leading to and connected with the supply main 3.

By reference to Fig. 2 of the drawings, it will be perceived that the section 4, constituting one-half portion of the valve casing, is formed with an integral extension at each side of its central portion, said extensions having a central opening therethrough forming a bearing for the valve stem 10, one extension 11 being formed with a screw-threaded socket within its outer end for the reception of a suitable packing sleeve 12 surrounding said stem, and the other extension 13 being formed with a central screw-threaded opening for the reception of the split or slotted end 14 of the valve stem and the adjustable valve stem retaining and locking means 15. The valve stem 10 is provided centrally within the valve casing with a flattened portion 16, which is embraced by the yoke-shaped end of an arm 17, said end and flattened portion being formed with an

opening therethrough for the reception of a suitable screw-threaded securing pin or bolt 18 for firmly securing the yoke end of the arm 17 to the valve stem, the other end of said arm being provided with an oblong opening therethrough for the reception of a screw-threaded bolt 18', for loosely securing said arm to the rocking valve 19, which valve is adapted to open and to securely close the gas inlet passage leading to the building.

Suitably secured around the upper end of the extension 11 is a tubular casing 20 extending upwardly above the grade, and secured in any suitable manner to the upper end of said casing is a cap 21, which is formed with a specially constructed integral top extension 22 for the reception of the standard wrench or other implement used by a fireman or other authorized person for the removal of said cap, and within said casing 20 is the upper end of the valve stem, which is preferably formed with a square contour at its outer end for the reception of a specially formed valve stem operating connection 23 formed at its top with an extension 24, corresponding in formation with the extension 22 of the cap 21, whereby the fireman or other authorized person may, when desired, cause the valve stem to be moved a quarter turn by the use of the standard wrench or implement, thus causing the valve, carried by said stem, to be rocked from the open into the closed position, this partial turn of the valve stem forcing the slotted end of the valve stem downwardly against the beveled end 25 of the stem retaining and locking means 15, thus expanding the split or slotted end of the stem into locked contact with the internally threaded portion of the extension 13 for firmly securing the valve 19 in its closed position.

It will be perceived that the retaining means such as is clearly shown in Figs. 2 and 8, consists of a screw-threaded headed bolt formed with a tapered or beveled inner end adapted to engage with the beveled formation within the lowermost end of the valve stem, and surrounding said bolt in engagement therewith is a lock nut 26, said retaining means being adjustably fitted to the lower threaded end of the extension 13, and when properly secured to said extension and adjusted into the desired contact with the lower end of the valve stem, the retaining means may be locked by the lock nut into its properly adjusted position, thereby firmly securing and retaining the shut-off valve 19 in its closed position.

In the slightly modified form of the lower screw-threaded end of the valve stem, said end of the stem is slotted or split crosswise at two places 27, as is clearly shown in Fig. 7.

The operation of my improved gas cut-off means may be briefly described as follows:

When a building equipped with gas distribution and consuming means is under conflagration or a portion or portions of the building is collapsed or any similar calamity occurs within a building, it is advisable to prevent explosions to securely cut off the flow of gas from the main supply to the said building; further, it is deemed advisable to so construct the gas shut-off means that only a fireman or other authorized person be in possession of the standard means to operate the gas cut-off means, hence when a fire or other calamity takes place within a building, it is only necessary for a fireman or other authorized person provided with the special standard implement to give a quarter turn to the cap 21, when it may be readily removed, then apply said implement to the headed portion, 24, of the valve stem operating connection 23, when by giving a quarter turn to said portion 24, a partial rotary movement will be imparted to the stem and to the valve, thus causing the valve to be moved from its open position shown in Fig. 3, to its closed position, such as shown in Fig. 4, and to be automatically retained in said closed position by the stem locking means, thus preventing any accidental opening of the valve caused by the jarring from heavy traffic or other reasons, and until it is opened by a fireman or authorized person provided with the proper standard implement employed for the direct operation of the valve.

Having thus described my invention what I claim and desire to secure by Letters Patent is:

1. A device of the character described, comprising a valve casing formed of two cast sections secured together, one section being provided with oppositely disposed integral extensions, a valve stem fitted vertically within said extensions formed with a flattened portion centrally of the casing and with a squared upper end and a lower slotted screw threaded end, a shut-off valve secured to said flattened portion, and operating means connected with the upper end of the valve stem.

2. A device of the character described, comprising a casing formed of two cast sections secured together at their meeting ends, one section being formed with an integral extension at each side thereof, a valve stem vertically mounted within said extensions and casing, said stem being formed with a square upper end, a flattened portion centrally disposed within the casing and a slotted screw threaded lower end portion, a cut-off valve secured to said flattened portion, and retaining means secured to one of the extensions and in contact with the slotted end of the valve stem to lock the valve and stem in closed position.

3. A device of the character described, comprising a casing formed with an integral

hollow extension at each side, a valve stem fitted within said extensions and casing and extending vertically, a cut-off valve secured to said stem, a tubular casing fitted around the upper end of one of said extensions entirely enclosing the upper end of the valve stem, valve stem locking means fitted in the lower end of the other extension and in contact with the lower end of said stem, and means within the tubular casing connected to the valve stem for closing the valve by imparting a quarter turn to the valve stem.

4. A device of the character described, comprising a casing formed with an integral extension at each side, a valve stem vertically fitted within said extensions and casing, a shut-off valve secured to said stem, said stem being formed with a screw-threaded split inwardly beveled lower end, valve stem retaining means secured to one of the extensions formed with a beveled inner end fitted within the end of the valve stem and a lock nut in contact with the outer face of the extension, and means secured to the upper

end of the valve stem for securely closing the valve by imparting a quarter turn to the valve stem.

5. A device of the character described, comprising a casing disposed at the outside of a building below the street grade, said casing being formed with an integral extension at each side, a vertically disposed valve stem mounted within said extensions and casing, a shut-off valve secured to said stem, a tubular casing mounted upon the upper end of one of said extensions and extending above the street grade, a cap secured to the tubular casing, a screw-threaded beveled split portion forming the lower end of said stem, adjustable stem retaining means fitted within the other extension and the lower end of the stem, and means secured within the tubular casing and to the upper end of the valve stem for closing the shut-off valve by a partial rotary movement of the valve stem.

JAMES S. McILHENNY.