

(19)
(12)

(KR)
(B1)

(51) 。 Int. Cl. ⁷
B61H 1/00

(45)
(11)
(24)

2002 07 25
10 - 0345240
2002 07 06

(21) 10 - 1999 - 0044096
(22) 1999 10 12

(65) 2001 - 0036897
(43) 2001 05 07

(73) 374 - 1

(72) 387 - 4 402

(74)
:

(54)

,

, ,

,

;

,

가 , ,

,

가 , ,

,

가 , ,

,

가 , ,

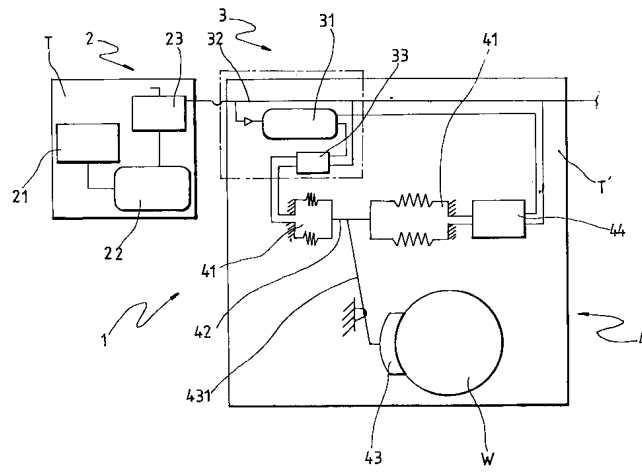

1

2a

2b

3

4

5a,b

<

- | | | |
|------------|----------|------------|
| 1 : | 2 : | 3 : |
| 4 : | 21 : | 22 : |
| 23 : | 31 : | 32 : |
| 33 : | 41,41' : | 42 : |
| 43 : | 44 : | 331,331' : |
| 332 : | 333 : | 334 : |
| 411,411' : | 431 : | 441 : |

442 : 443 : 444 :

W : T : T' :

가 (100) (100) (T) (10) 가 ,
 (20) , ,
 1 (T) (30) ,
 (Freight car) (40) (20) (40)
 (5kg/cm²) 가 (20) (40) (20)
 (40) 가 , ,
 (40) (20) (50) , (60)
 (60) (W) (70)가 .
 가 (T) (10) (20) (100) , (20) ,
 (50) (40) (70) (70)
 , (60) (W) ,
 (10) , (20) (40)
 (20) (50) (70)
 , (S) (W) (60)
 , (50) 2 a,b , 2a
 (20) 가 (50) 가 3 (40) ()
 70) (40) (70) ,
 (20) (50) (70)
 (S') (70)
 , (60) (W) .
 , (100) (50) (40)
 가 (70) (60) (W)
 (S,S') (S,S')
 (60) ,

$$\Sigma F = pA - K\chi$$

p : , A = , K = , \chi =

(70)

(S, S')

(50)

가

(20)

가

가

가

가

4

5a,b

(2)

(3)

(4)

(21) (2)

(22)

(22)

(21)

(23)

(31) (3) 4 5a,b (31) , (31)
 (32) (2) (32) , (31)
 (33) .

(31) (32) , (33)
 (23) (32) ,

(33) 5a,b (331,331') (332) ,
 (333) , (333) (332)
 (334)가 (32) (31) (31)
 (V) (31) 가 .

(4) 4 5a,b (42)
 (41,41') , (431) (43) ,

(41,41') (411,411') (42)
 (41) (411) (33) (44)
 332) , (41') (411') (44) .

(44) 5 (31) (32) (441)
 (442) , (442) , (444)가

(431) (43) 4 (42) (431)

(43) (W) (42) (43)
 1) (W) .

(1)

4 (T) (21) (T') (31)
 (32) , (32) (31) (5kg/cm² .)
 가 (23) , (32) ,

5a (32) (33) (31)
 (411) (411) ,

(32) (44) (441) (442) ,
 ()가 (442) (443)
 (31) (411')
 (444) (442) (411')

(411') 가 (41) (31)
 (431) (43)

, (23) , (32) ,
 5 b (32) (33) (41)
 (31) (41) (411)
 , (32) (44) (441) (442) ,
 가 (442) (443) (444)
 (31) (41') 가 , (444)
 , (41')
 ,
 , (43) , (32) 가 (44) ,
 (41,41')
 , (1) ,
 .

가 ,

(

(57)

1.

(21) (22) (T) , (22) ,
 (23)가 (2) ,
 (T') (31) (32) (23) ,
 (31) (32) (33)가 (3) ,
 (41,41') (42) , (41) (33) ,
 (41') (31) (23) , (44)가 ,
 (42) (43) (431)가 (4) ,
 (32) (41,41') (431) , ,

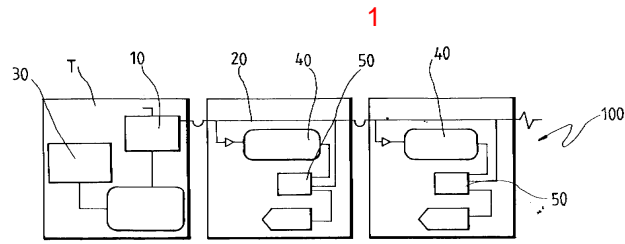

2a

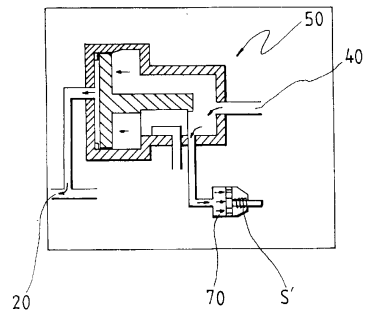

2b

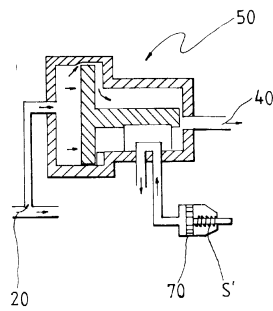

3

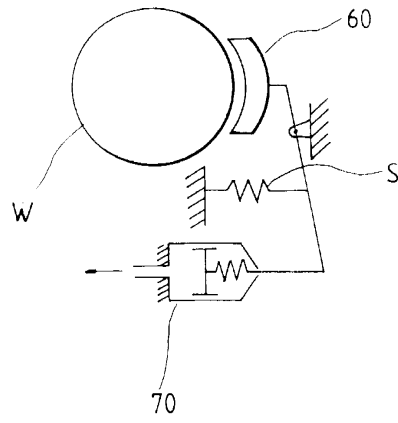

4

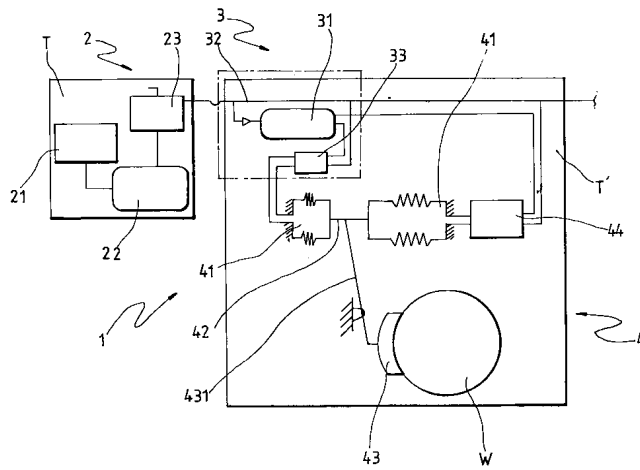

5a

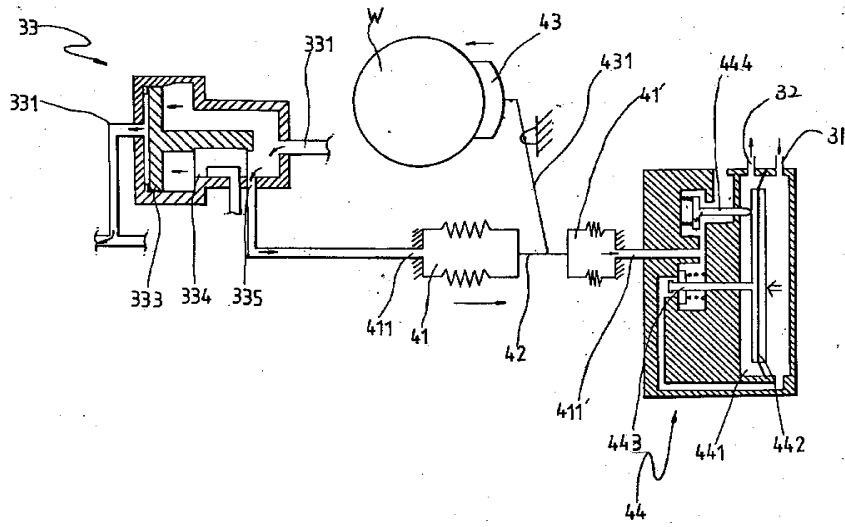

5b

