



(72) VASUDEVA, KAILASH C., CA

(71) MAXTECH MANUFACTURING INC., CA

(51) Int.Cl.<sup>6</sup> B25H 3/04, A47B 81/00

(30) 1998/08/14 (60/096,693) US

(54) **DISPOSITIF DE RETENUE AVEC MECANISME DE SECURITE  
DE MANCHON POUR TOURNEVIS OU OUTILS DU MEME  
GENRE**

(54) **HOLDER WITH SHAFT SECURITY MECHANISM FOR  
SCREWDRIVERS OR THE LIKE**

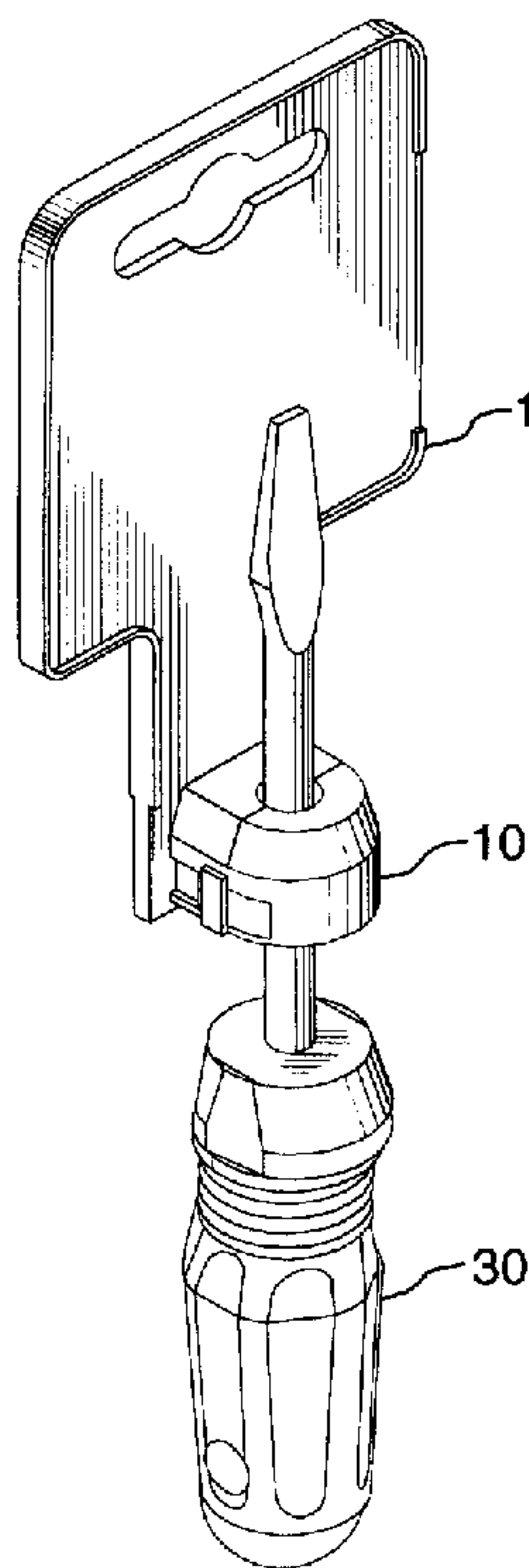

(57) A security mechanism adapted to a tool holder comprising a first member and a second member pivotally connected to the first, each of the members having a recessed portion defined on a mating surface to receive a portion of a tool shaft whereby a handle portion and/or other part of the secured tool is positioned outside of the security mechanism and the holder and is accessible to a user. The shaft security mechanism includes, preferably, a variable position locking means for securing the first and second members in the closed position in one of a number of locking positions. Preferably, a compressible insert slidably mountable onto the tool shaft portion may be inserted and registered into a cavity further defined by the recessed portions of the first and second members when the security mechanism is in an open position.

**ABSTRACT**

A security mechanism adapted to a tool holder comprising a first member and a second member pivotally connected to the first, each of the members having a recessed portion defined on a mating surface to receive a portion of a tool shaft whereby a handle portion and/or other part of the secured tool is positioned outside of the security mechanism and the holder and is accessible to a user. The shaft security mechanism includes, preferably, a variable position locking means for securing the first and second members in the closed position in one of a number of locking positions. Preferably, a compressible insert slidably mountable onto the tool shaft portion may be inserted and registered into a cavity further defined by the recessed portions of the first and second members when the security mechanism is in an open position.

## **HOLDER WITH SHAFT SECURITY MECHANISM FOR SCREWDRIVERS OR THE LIKE**

This invention relates to tool holders with shaft security mechanisms, i.e. means to retain tools in their packaging, via shaft portions thereof, for example, such that they are impossible or at least difficult to remove while the packaging remains in place.

The invention is particularly applicable to screwdrivers and the like, but could be used for any article having a generally straight shaft or shank, whether round, square, hexagonal or otherwise shaped in cross-section. Other examples of tools or tool components which could be retained would include nut drivers, drills, taps, hex power bits, etc., for example.

Traditional screwdriver holders comprise multiple parts, for example a holder base and a twist tie wrapped about the handle portion of the screwdriver to hold the screwdriver to the holder. There a number of problems with these traditional holders. First, the screwdriver is not actually secure from product price switching by unscrupulous individuals. Because screwdrivers in traditional packaging/holders are easily removable therefrom, an unscrupulous individual may remove the tool from a higher priced packaging/holder and insert the desired tool into a lesser priced package/holder. To resolve the problem of product price switching some traditional packaging/holders keep the screwdriver in a completely sealed box or compartment. The problem with this latter form of packaging is that the potential customer does not have an opportunity to grip and feel the handle of the tool before purchasing. Market research shows that allowing the potential customer accessibility to the grip and feel of the handle portion of the screwdriver will give the customer a better assessment of whether to screwdriver is best suited for his/her purposes and taste.

Accordingly, there exists a need for a screwdriver holder that can securely hold the screwdriver in the packaging/holder it is originally packaged in while at the same time allowing the potential customer to feel and grip the full length of the handle portion.

It is an object of the invention to overcome some of the drawbacks of traditional tool holders.

It is another object of the invention to provide an one piece holder that permits a potential customer to grip and feel the handle portion of the tool he/she is intending to purchase without removing the same from the holder.

The invention therefore provides a tool holder having a shaft security mechanism adapted to the holder, comprising a first member and a second member securable to the first member, each of the members having a recessed portion defined in a mating surface, the security mechanism being positionable between an open position where the first and second members are displaced from one another, and a closed position where the first and second members mate with one another and secure a shaft portion of a tool passing through the recessed portion. A locking means is secures the first and second members in the closed position.

Further features of the invention will be described or will become apparent in the course of the following detailed description.

In order that the invention may be more clearly understood, a preferred embodiment thereof will now be described in detail by way of example, with reference to the accompanying drawings, in which:

Fig. 1 is a perspective view of the holder with a single screwdriver being secured;

Fig. 1a is a perspective view of the holder without a screwdriver;

Fig. 2 is a close-up perspective view of a shaft security mechanism in an open position;

Fig. 2a is close-up perspective view of another embodiment of the shaft security mechanism;

Fig. 3 is a perspective view of a shaft mounted compressible insert installed into an open shaft security mechanism;

Fig. 4 is a perspective view of the screwdriver and compressible insert;

Fig. 5 is a front view of the holder and secured screwdriver;

Fig. 6 is a side view of Fig. 5;

Fig. 7 is a close-up front view of Fig. 3;

Fig. 8 is a partial side cross-sectional view through shaft security mechanism;

Fig. 9 is a side cross-sectional view through the holder;

Fig. 10 is a top cross-sectional view through an open shaft security mechanism;

Figs. 11 -12 are top cross-sectional views of the shaft security mechanism illustrating how the mechanism is locked;

Fig. 13 is a perspective view of a multiple screwdriver holder;

Fig. 13a is a cross-sectional view through a second embodiment of the shaft security mechanism;

Fig. 14 is a plan view of an unsecured multiple screwdriver holder;

Fig. 15 is a sectional view of the multiple screwdriver holder;

Fig. 16 is a sectional view of the multiple screwdriver holder with a screwdriver positioned in the shaft security mechanism;

Fig. 17 is a plan view of the multiple holder with a screwdriver secured therein;

Fig. 18 is a side view of the multiple holder with a screwdriver secured therein;

Fig. 19 is a sectional view of Fig. 18;

Figs. 20 - 24 are various views of an alternative embodiment of the tool holder that permits rotation of the security mechanism to allow the screwdriver to be stored during shipping/storage;

Figs. 25 - 29 are various views of another embodiment of the invention in which a rib in the recess has been added to 'bite' into the rubber insert thus causing added compression;

Fig. 30 is a front view of an alternative embodiment;

Fig. 31 is a side view of the Fig. 30 embodiment;

Figs. 32-34 are perspective views of another alternative embodiment;

Fig. 35 is a front view of the embodiment of Figs. 32-34;

Fig. 36 is a side view of the embodiment of Figs. 32-34;

Fig. 37 is a blank view of side view of an alternative embodiment, configured for a drill bit; and

Fig. 38 is a side view of the Fig. 37 embodiment.

A preferred embodiment of the invention is shown in Figs. 1 - 12. With reference to Fig. 1 there is shown a single tool holder, generally designated as 1, with

a shaft security mechanism **10** disposed at a lower portion thereof for securing a shaft portion of a screwdriver **30** or the like. The holder will preferably have a tab opening near a top end thereof for receiving a displaying shelving rod since the practical application of this holder will be in retail or wholesale settings. The holder and shaft security mechanism will be typically integrally molded from plastic or other suitable material.

The security mechanism is positionable between an open position, as shown in Fig. 2, and a closed position, as shown in Fig. 1 and 1a. The security mechanism comprises a stationary first half **12** abutting the face of the holder and a second half **14** connected to the first half via, preferably, a living hinge **16**. On the mating surfaces of the first and second halves is a recessed cavity, generally designated **18**. In the preferred embodiment, the recessed cavity is shaped so as to house a compressible washer/insert/grommet **11** snugly therein. In this preferred embodiment, the cavity has an intermediate tier **20** to assist in retaining the compressible insert in place and generally resisting any upward or downward shifting of the shaft when the secured tool is yanked by a customer. The mechanism includes a variable position locking means preferably comprising a ratcheting teeth tab **22** that is insertable into receiving end **24** and locked by one-way pin **26**. Although only three teeth are shown in the drawings, a different number of teeth will also work. Likewise, the halves can be of different shapes and sizes than illustrated, but still fall within the scope of the invention. Other variable position locking means are possible that will achieve the same result. One such alternative embodiment is illustrated in Fig. 13a. In this second embodiment, there are two ratcheting teeth tabs instead of one. In all cases, however, the variable position locking means permits the assembler to adjust the security level of the security mechanism for each retailer/wholesaler's particular requirement, by selecting one of a number of locking positions, ranging from somewhat loose to very tight.

With reference to Fig. 4, the compressible insert **11** has a central bore extending therethrough and is made of a material that is sufficiently elastic, such as PVC, Santoprene™ or rubber, so as to allow the insert to be slidably mountable onto the shaft of a tool regardless of whether the tip of a screwdriver has flared sides or not. In the same sense, the compressible insert may be slid off the shaft when no longer

required. However, the material and/or fit is such that it resists movement along the shaft unless considerable force is applied. In a preferred embodiment, the compressible insert has two spaced-apart portions radially extending from a central shaft, the top portion of which is bevelled. When the security mechanism is in the open position, the shaft mounted insert is positioned therein as shown in Figs. 3 and 7. After insertion, the tool is secured to the holder by simply closing the second half of the security mechanism against the first half and locking the same. An illustration of how the shaft of tool is secured to the holder via the insert is shown in Figs. 3, 7 and 10 - 12.

Depending on the security packaging requirements of the retailer/wholesaler a wide range of security levels may be achieved with this shaft security mechanism. In situations where the requirements call for high security means, the assembler of the holder and tool simply inserts the teeth a few more levels deeper past the pin 26. Since the insert is compressible the insert will accept tighter locked fits. Once locked, the secured screwdriver or other tool or item cannot be readily removed from the security mechanism without either tediously disassembling the tool from the holder or breaking open the locking means. In the least secure level, the tool may be twisted about its axis and in the most secure level, the tool is fixed in one position.

Advantageously, this overall scheme of the invention allows the potential customer to grip the tool handle and get a sense of how the tool feels before purchasing the same, while making it difficult, if not impossible, for the unscrupulous person to product price switch.

Furthermore, the same tool holder may be, advantageously, shipped to a wider range of retailers/wholesalers who have different security packaging requirements. This will reduce packaging costs of a tool or a tool set.

Another advantage that flows from the invention is the fact that the packaging avoids the flimsy look of a blister package typically associated with traditional packaging of the tools. The invention, also advantageously, provides for single piece holder to be integrally molded holder thereby allowing a sturdy and durable package.

A multiple screwdriver holder embodiment is shown in Figs. 13 - 19 having a security mechanism similar to that described above and having similar advantages that flow from its design. In this embodiment of the invention, a number of screwdrivers 50 are stored in the holder base 40 by aligning the bore 51 of the handle into upwardly

extending tabs **44** and the shafts with recessed cuts **43** of the support members **42**. The screwdrivers stored in the base are held in place by the combination of strap **46** and label card **45**. This strap and card combination is connected to the holder via a living hinge and locks therewith via thumb tack **48** - hole **49** combination. The locking mechanism according to the invention is applied as shown in Figs. 16-19, such that one of the screwdrivers has its handle fully exposed for the prospective purchaser to feel. The strap **46** prevents the remainder of the screwdrivers from being removed easily.

Figs. 20 - 24 are various views of an alternative embodiment of the tool holder, similar to the one shown in Figs. 13-19, which permits rotation of the security mechanism to allow the screwdriver to be rotated from the shipping/storage position of Figs. 20-21, to the preferred display position of Figs. 22-23, by virtue of pivotal mounting of the security mechanism via a mushroom pin **60**, best seen in Fig. 24.

Figs. 25 - 29 are various views of another embodiment of the invention in which a rib in the recess has been added to 'bite' into the rubber insert thus causing added compression of the insert, for more force against the tool.

Figs. 30-31 show an alternative embodiment, having a ratcheting locking strap which wraps around the handle of the screwdriver, and a snap-on cap to fit over the end of the screwdriver.

Figs. 32-36 are various views of a similar alternative embodiment, further having a locking clip which fits closely around the screwdriver shaft and then snaps into place on the card. In this embodiment, the ratcheting locking strap is not necessary, although obviously it could be used as well for greater security.

It will be appreciated that the above description relates to the preferred embodiment by way of example only. Many variations on the invention will be obvious to those knowledgeable in the field, and such obvious variations are within the scope of the invention as described and claimed, whether or not expressly described.

For example, the security mechanism may be used without the insert at all. What is required in this instance is that the hole **15** have an interference fit with the shaft of the tool and/or the diameter of the hole be less than the width of the flared ends of the secured screwdriver. In this embodiment of the invention, as shown in Fig. 2a, the recesses may be shaped to receive only the tool shaft portion. As a further

embodiment of the invention, the recessed portion of the members may instead be coated with a rubberized layer in lieu of the compressible insert.

**THE EMBODIMENTS OF THE INVENTION IN WHICH AN EXCLUSIVE PROPERTY OR PRIVILEGE IS CLAIMED ARE DEFINED AS FOLLOWS:**

1. A tool holder comprising at least one tool security mechanism adapted to the holder, said tool security mechanism comprising a first member and a second member securable to the first member, each of the members having a recessed portion defined on a mating surface to receive a portion of a tool shaft, the security mechanism being positionable between an open position where the first and second members are displaced from one another, and a closed position where the first and second members mate with one another and secure the tool shaft portion between the recessed portions.
2. A tool holder as recited in claim 1, wherein a compressible insert slidably mountable onto the tool shaft portion may be inserted and registered into a cavity further defined by the recessed portions of the first and second members when the security mechanism is in said open position, said compressible insert being trapped within said cavity when said security mechanism is in said closed position.
3. A tool holder as recited in claim 2, further comprising variable position locking means for securing the first and second members in the closed position in one of a variety of possible locking positions.
4. A tool holder as recited in claim 3, wherein said locking means comprises a plurality of teeth on at least one tab on one of said members and a corresponding one-way teeth receiving grip on the other said member to register the plurality of teeth therein.
5. A tool holder as recited in claim 4, wherein the security mechanism is disposed at a lower portion of the holder.
6. A tool holder as recited in claim 1, wherein an orifice defined by an upper surface of the recessed portions is lesser in diameter than the tool shaft portion.

7. A tool holder as recited in claim 1, wherein a plurality of screwdrivers are disposed a base thereof and secured thereon by upwardly extending tabs and a lid-like member connected to the holder via a living hinge.
8. A tool holder as recited in claim 1, wherein said members are connected via a living hinge.
9. A point of sale package for screwdrivers or the like having a shaft security mechanism adapted thereon, said mechanism comprising:
  - a first member adapted onto a base of the package,
  - a second member adapted onto a cover of the package pivotally connected to the base by a living hinge, the cover being positionable between an open and close position, each of the members having a recessed portion defined on a mating surface to receive a portion of a tool shaft,
  - the security mechanism being positionable between:
    - an open position where the first and second members are displaced from one another, and
    - a closed position where the first and second members mate with one another and secure the tool shaft portion between the recessed portions and whereby a handle portion of the secured tool is positioned outside of the package for easy accessibility
10. A package as recited in claim 9, further comprising variable position locking means for securing the first and second members in the closed position in one of a variety of possible locking positions.
11. A package as recited in claim 9 wherein a plurality of tools are stored on said base and secured thereon by fastening means and the cover in the closed position.

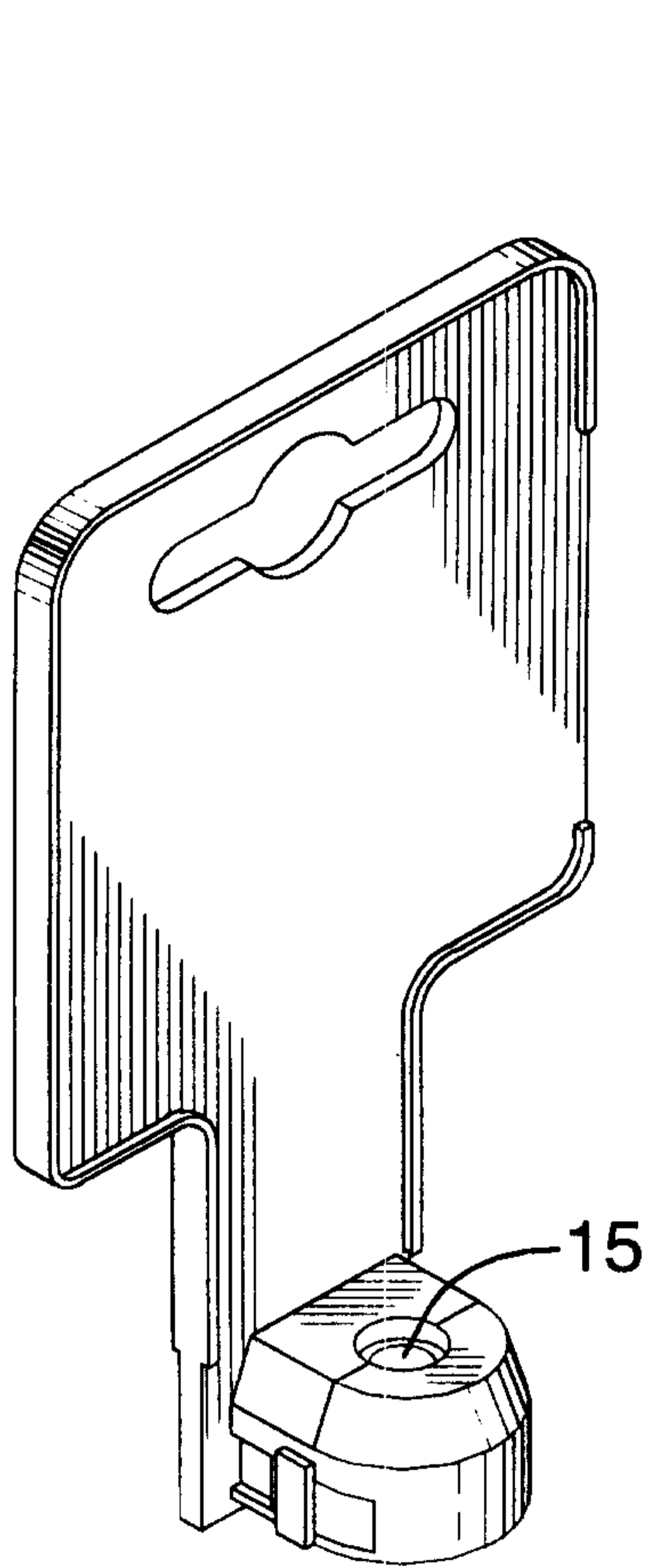

FIG. 1A

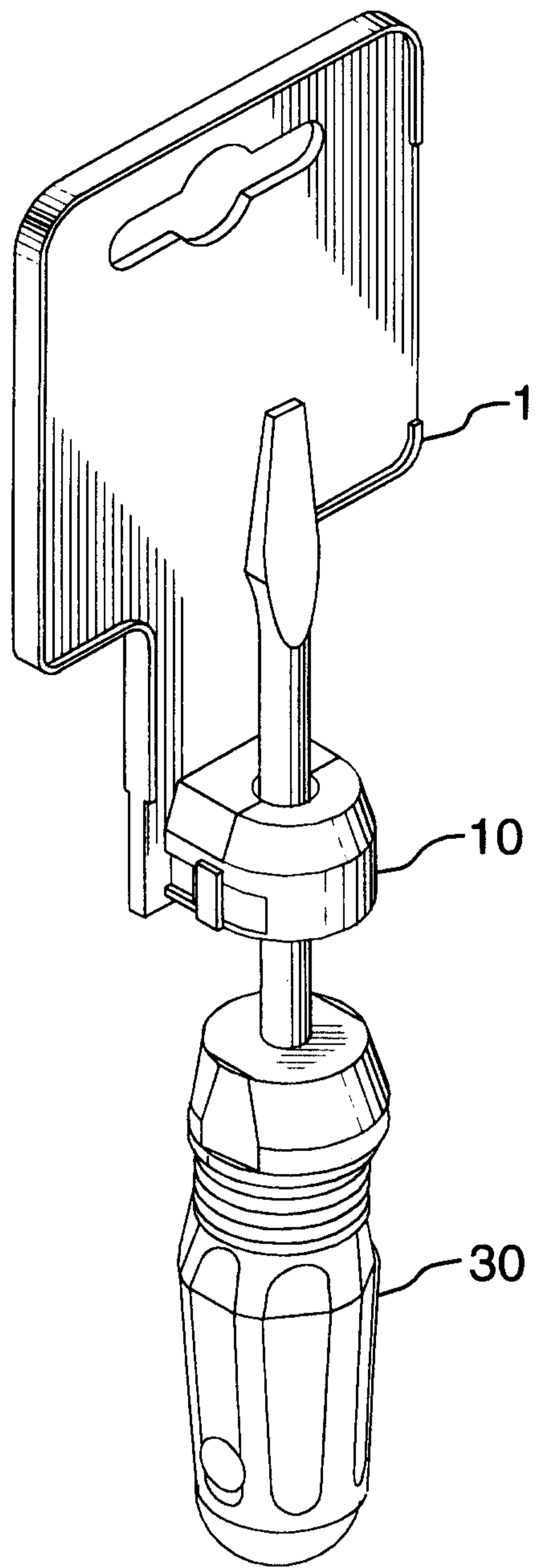

FIG. 1

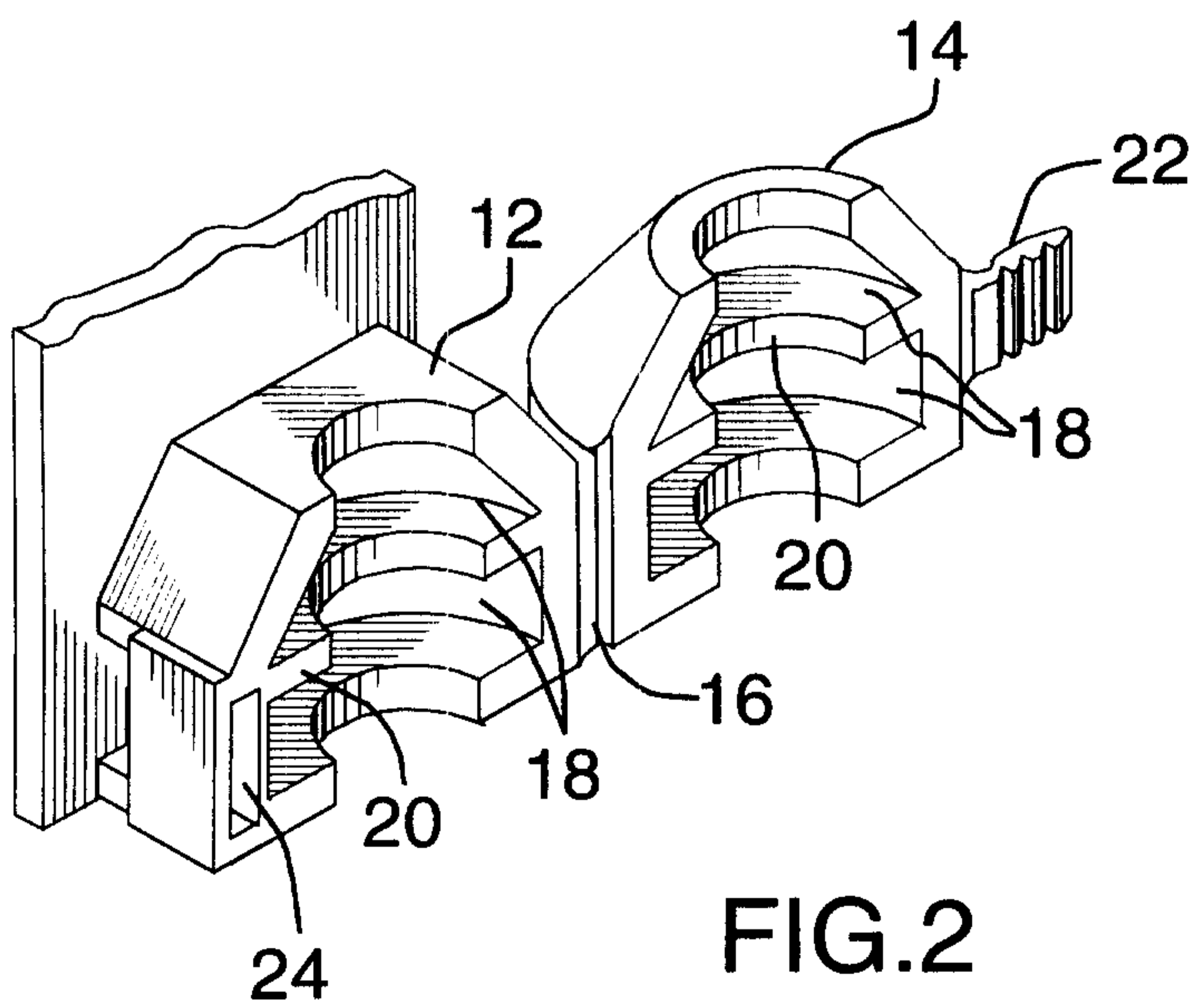

FIG. 2

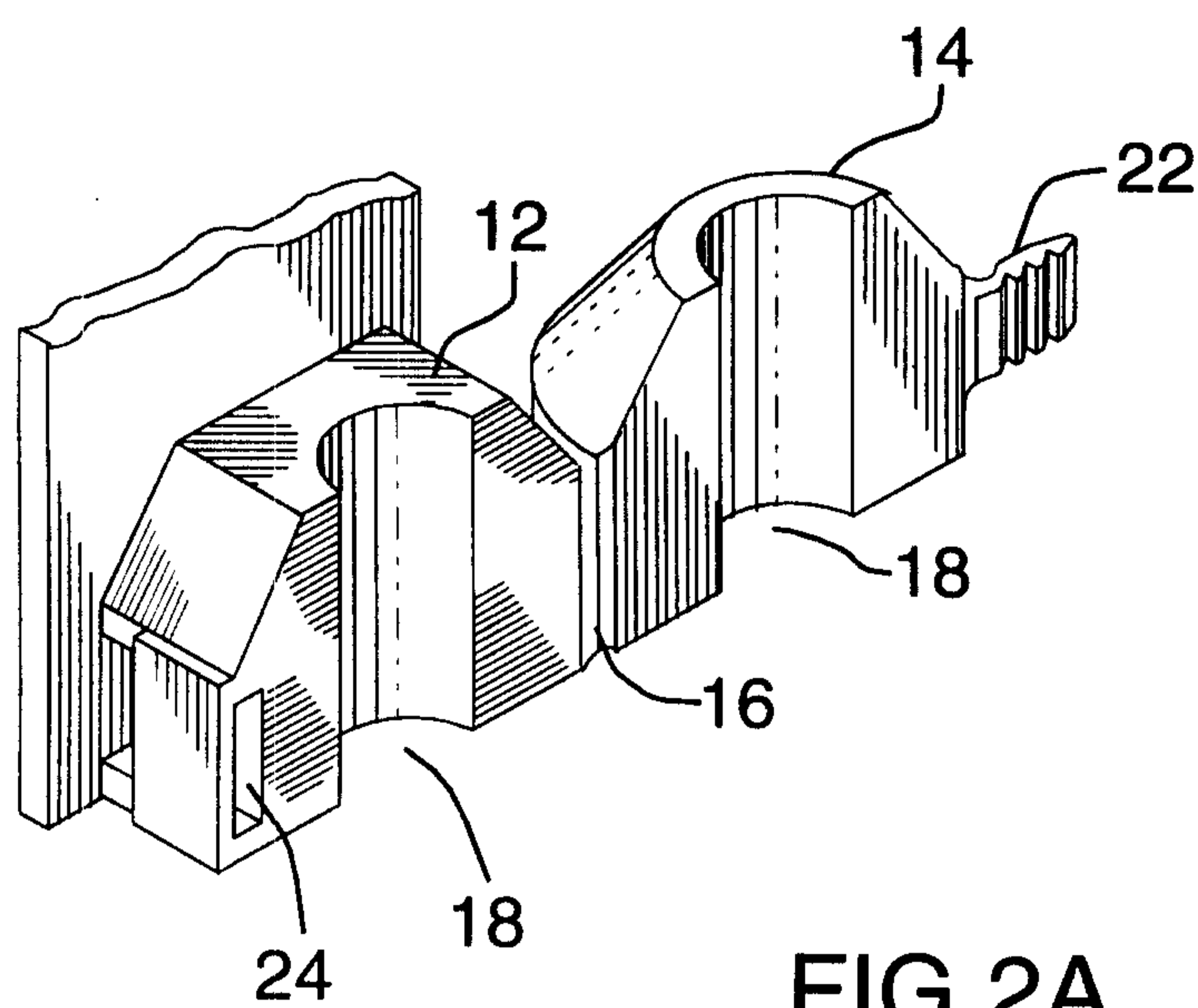

FIG.2A

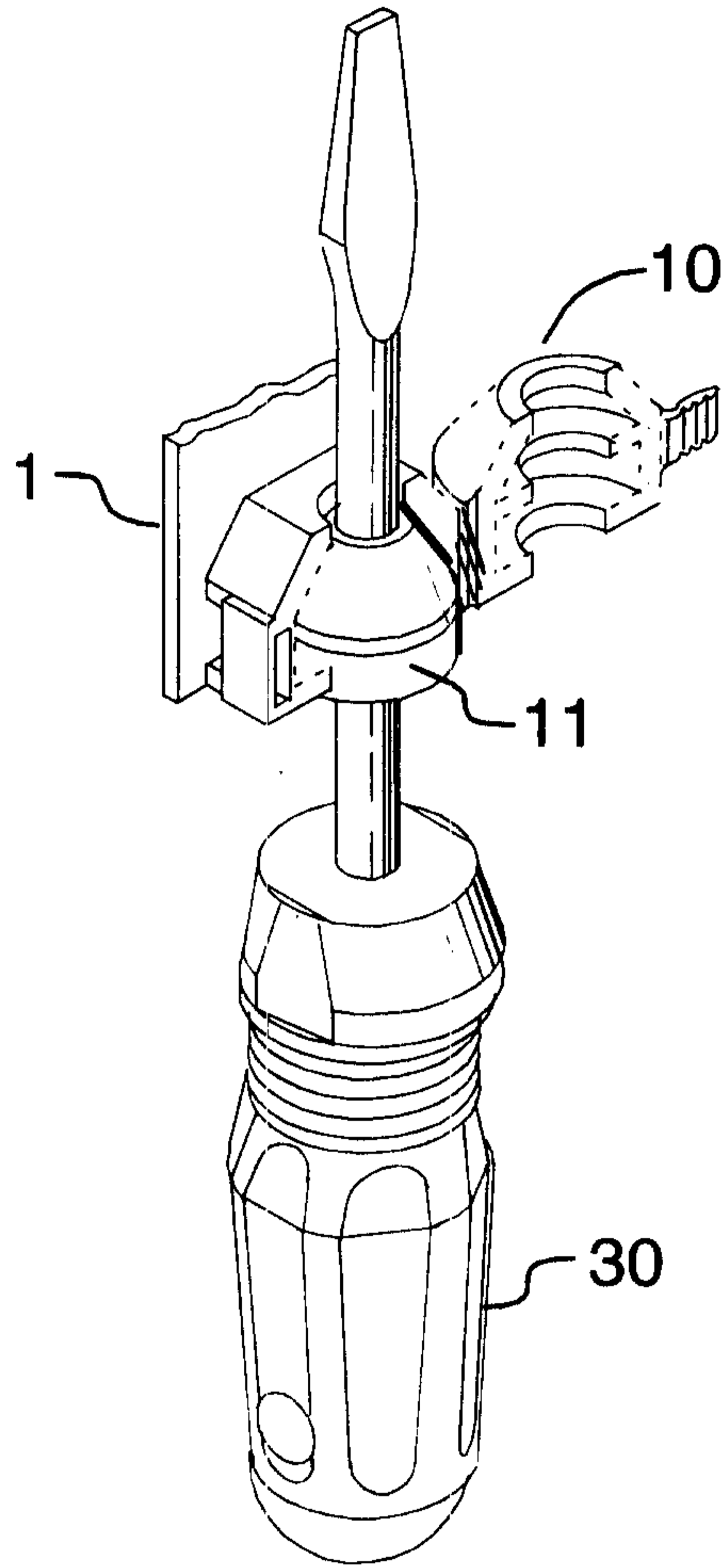

FIG. 3

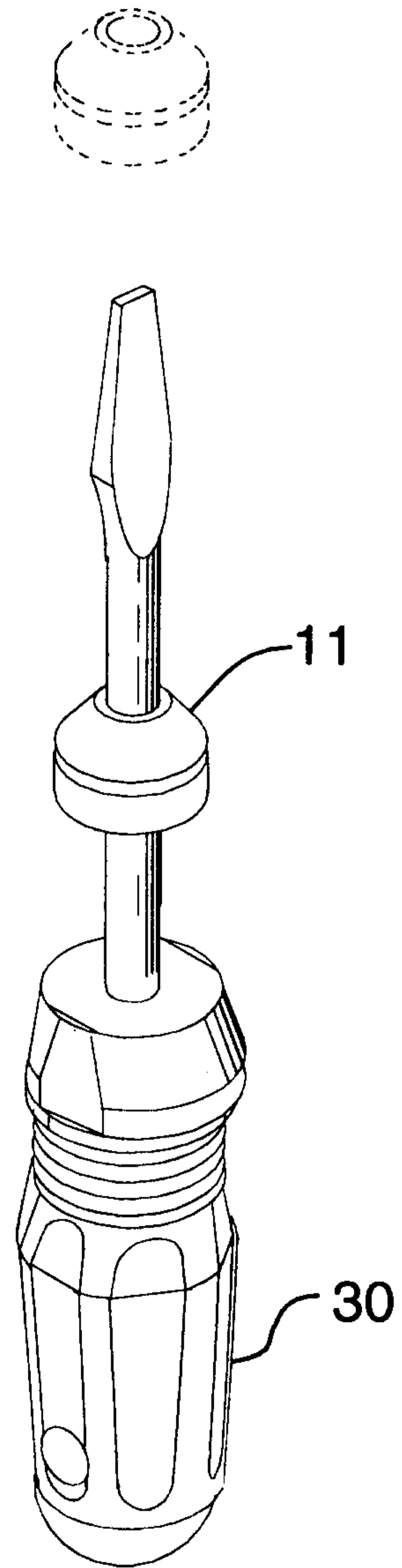

FIG. 4

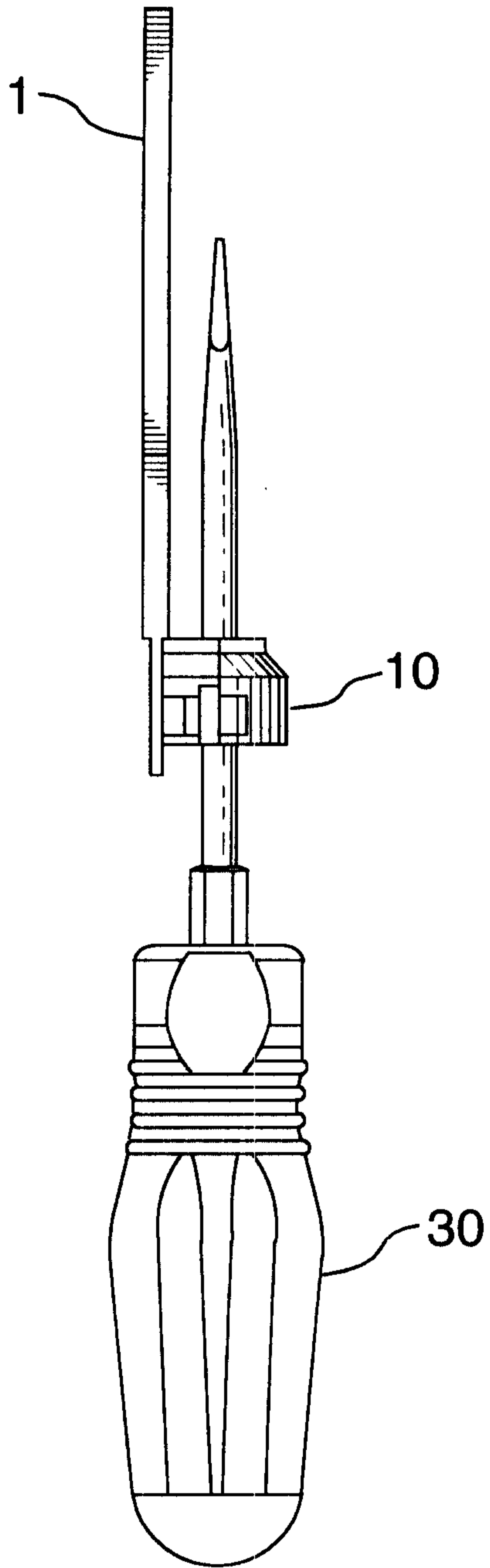

FIG. 6

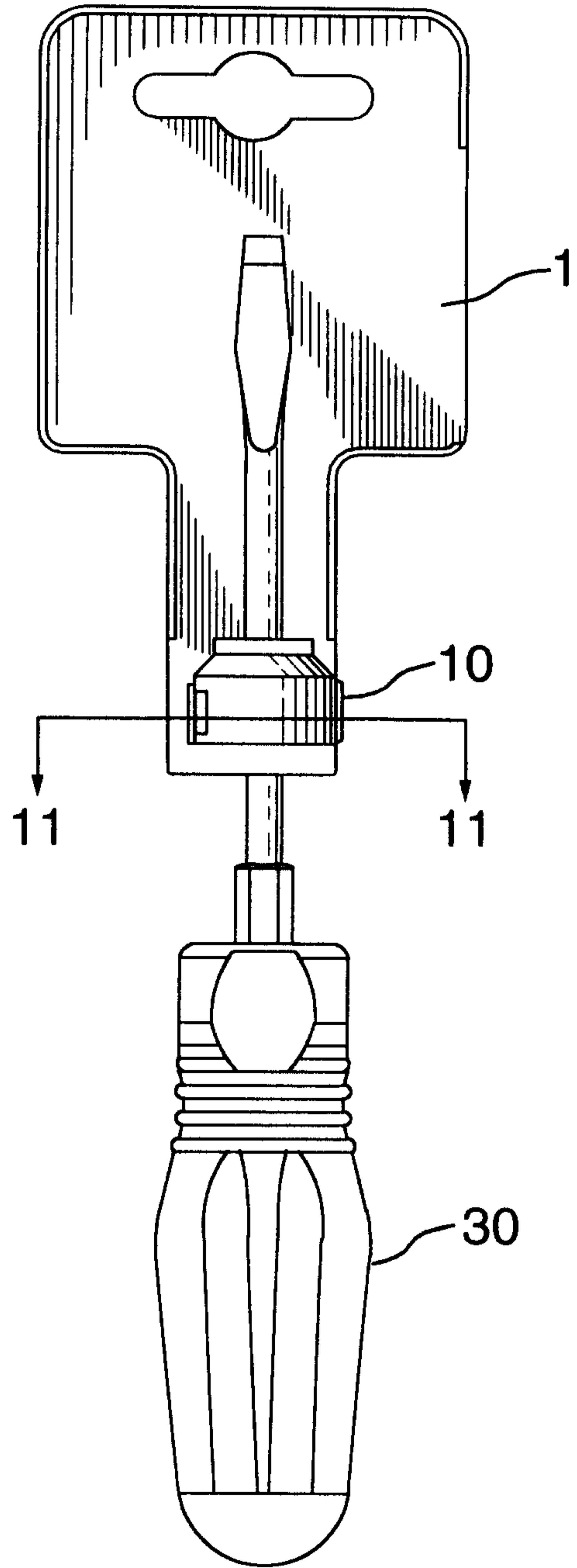

FIG. 5

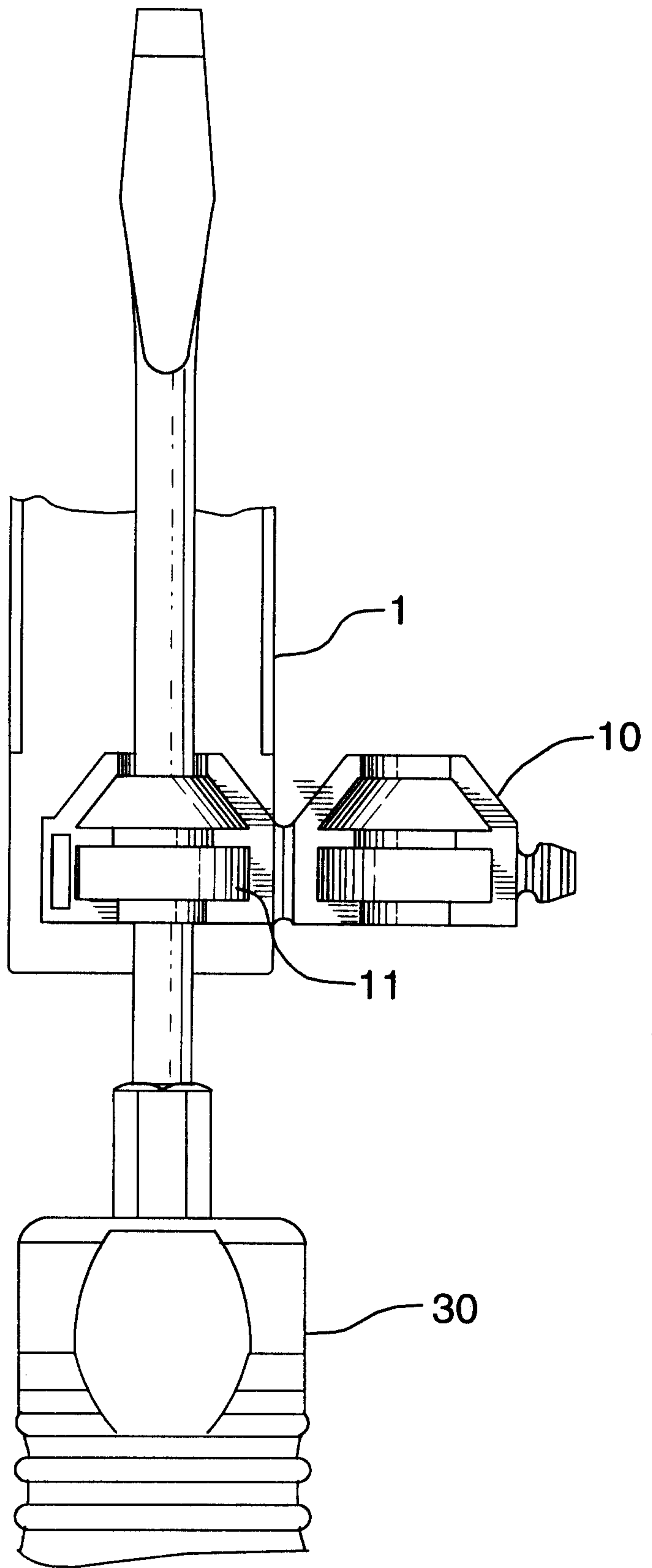

FIG.7

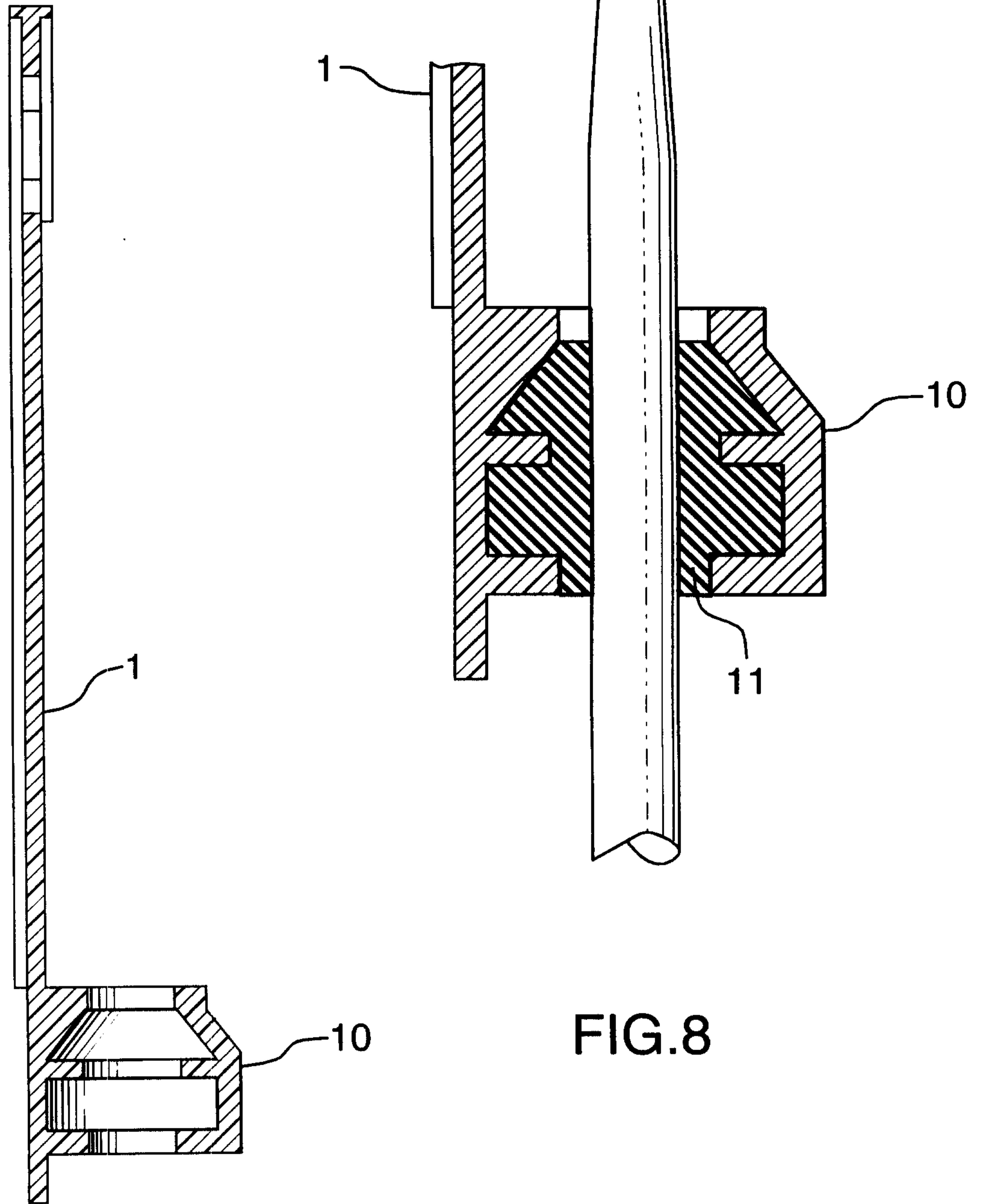

FIG.9

FIG.8

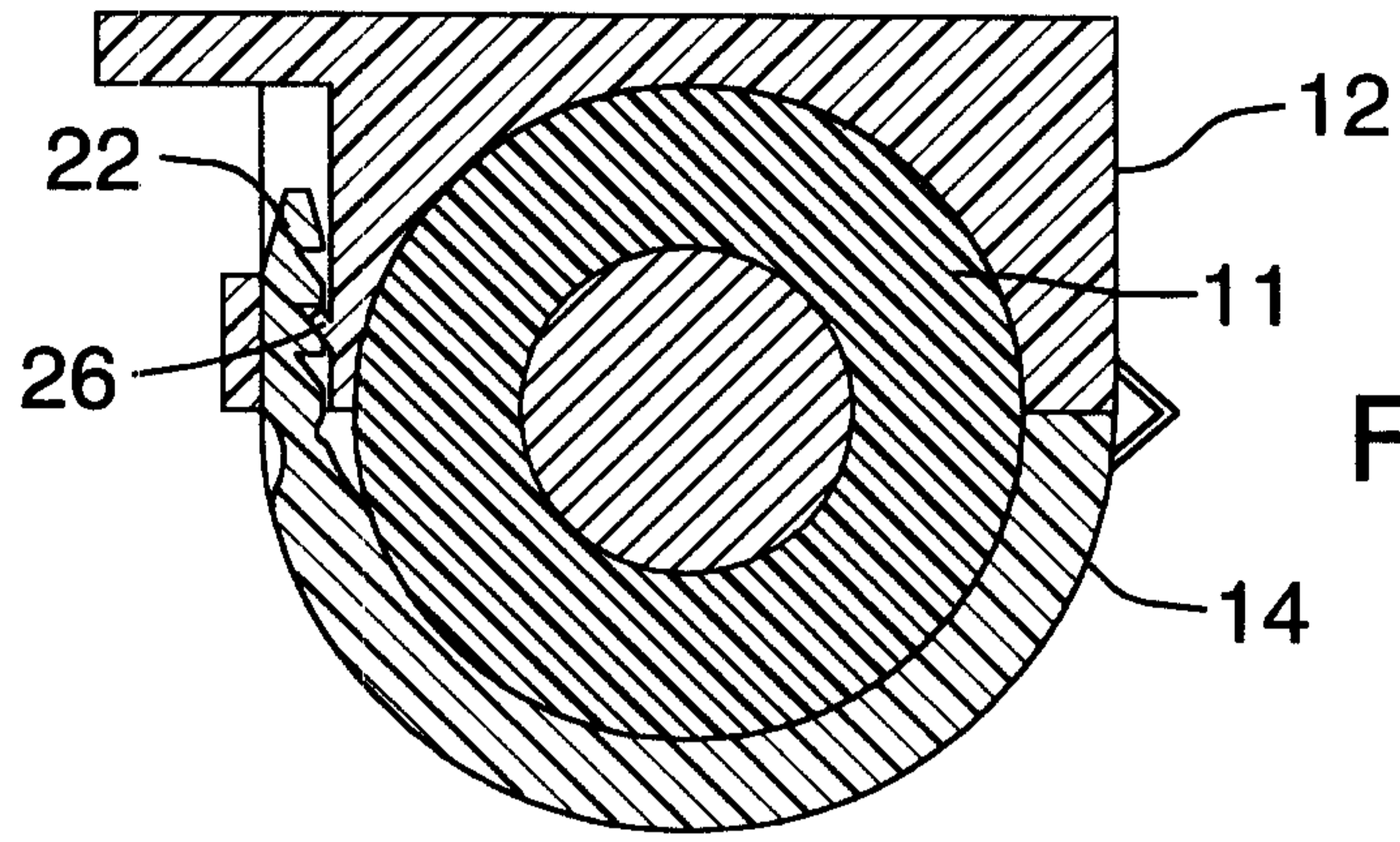

FIG. 12

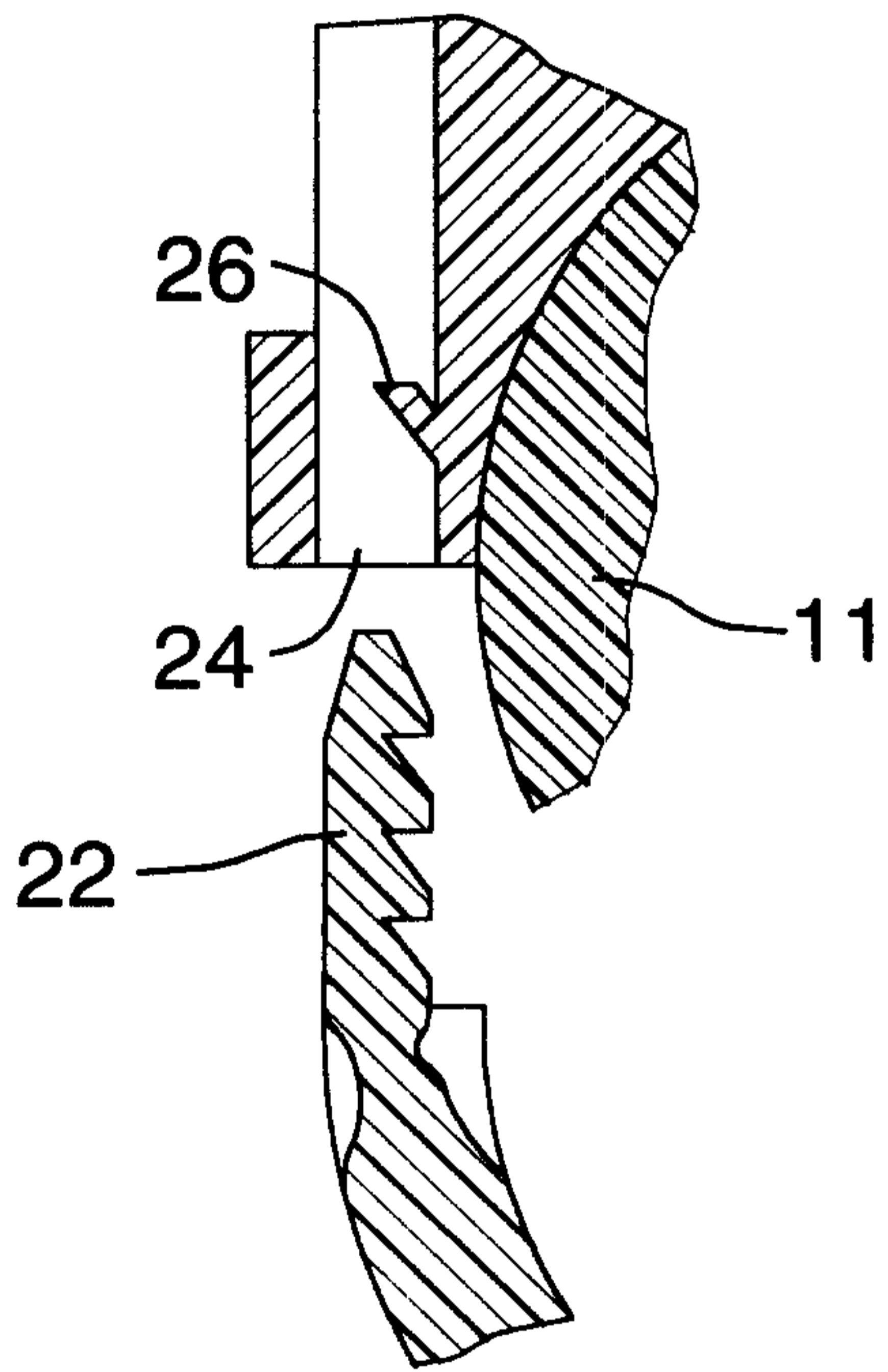

FIG. 11

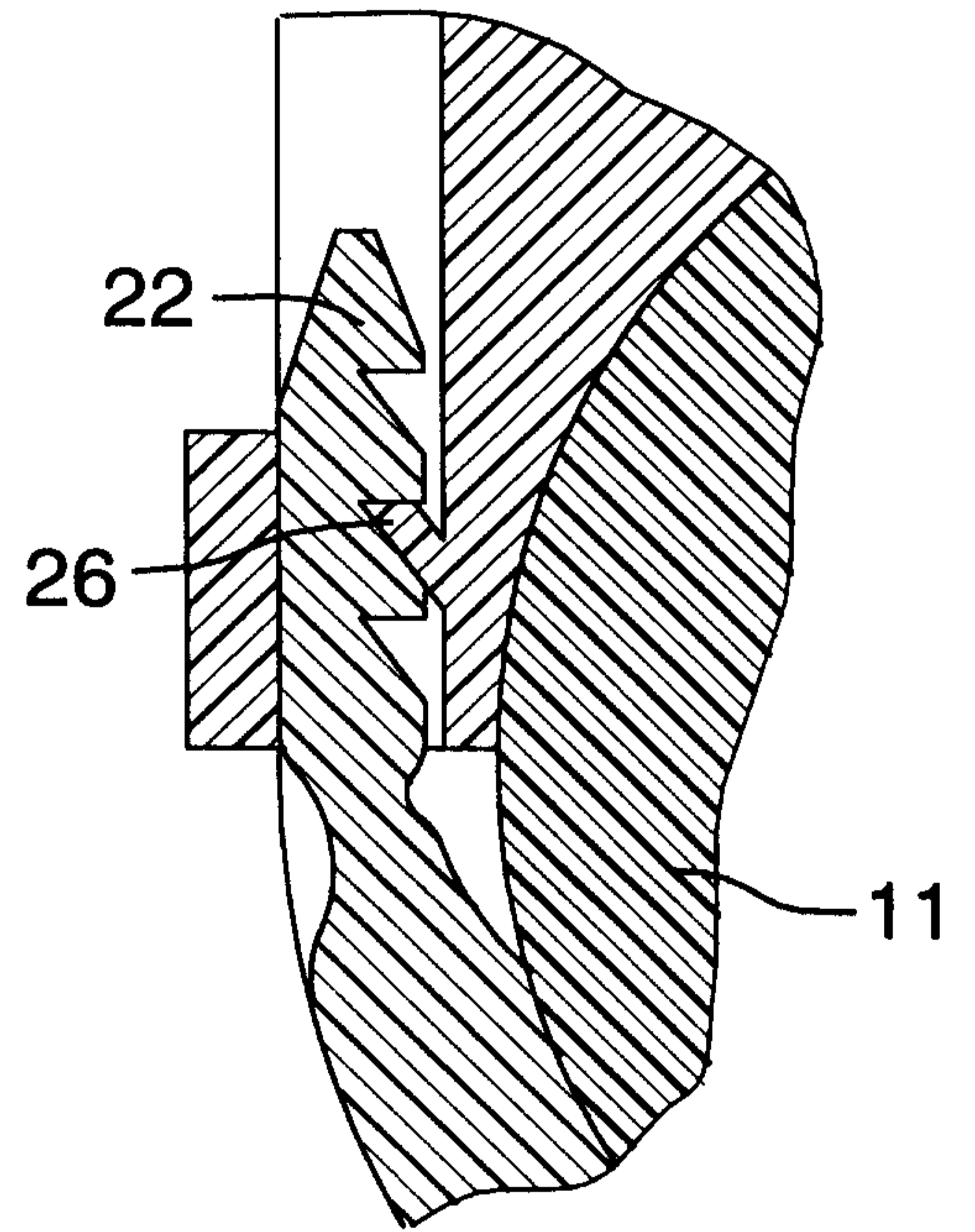

FIG. 11A

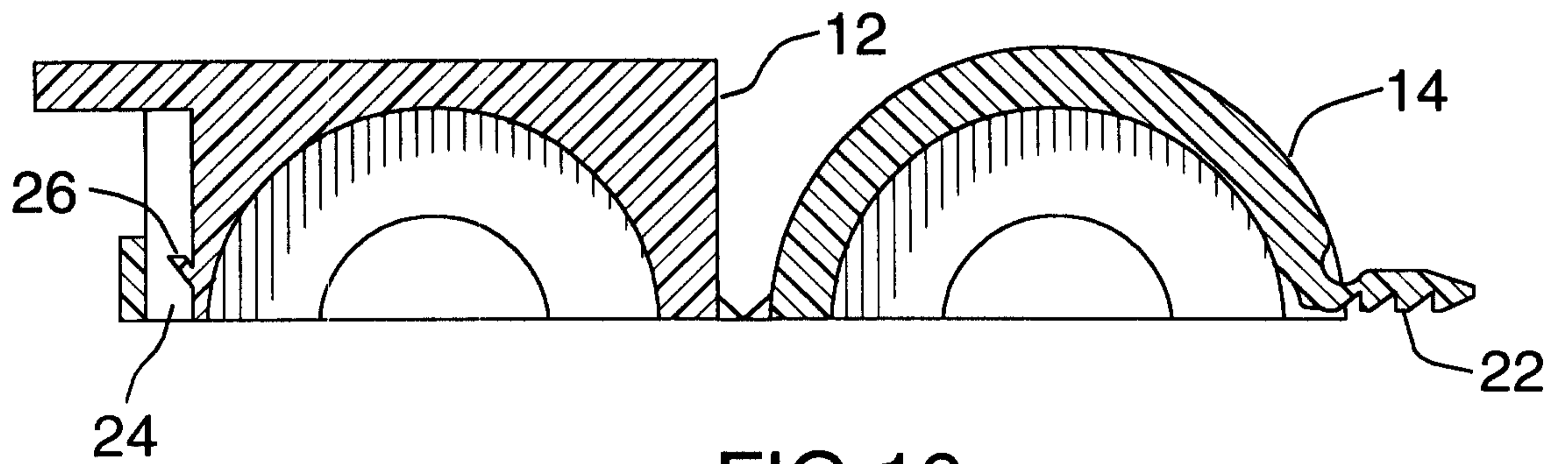

FIG. 10

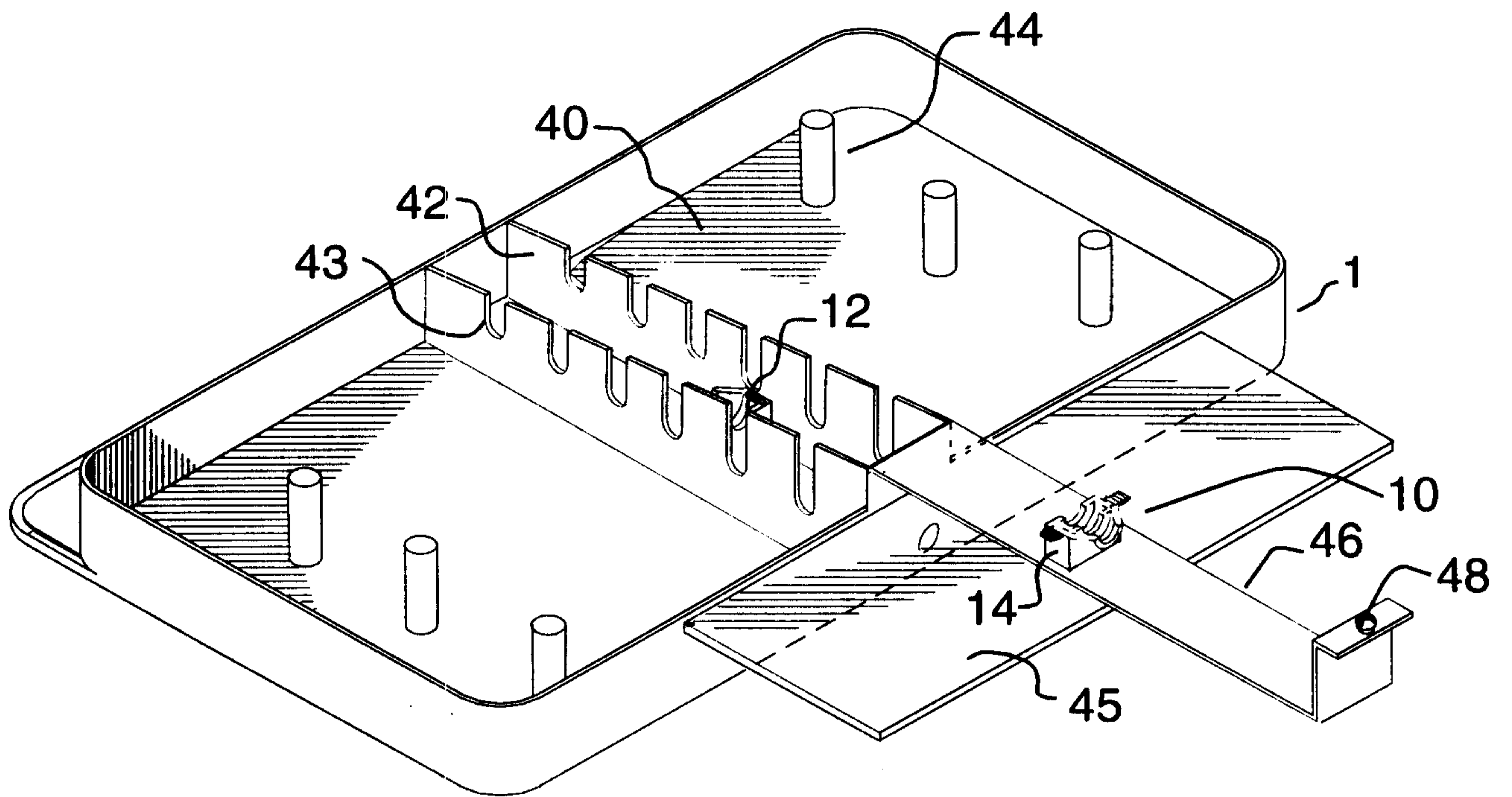

FIG.13

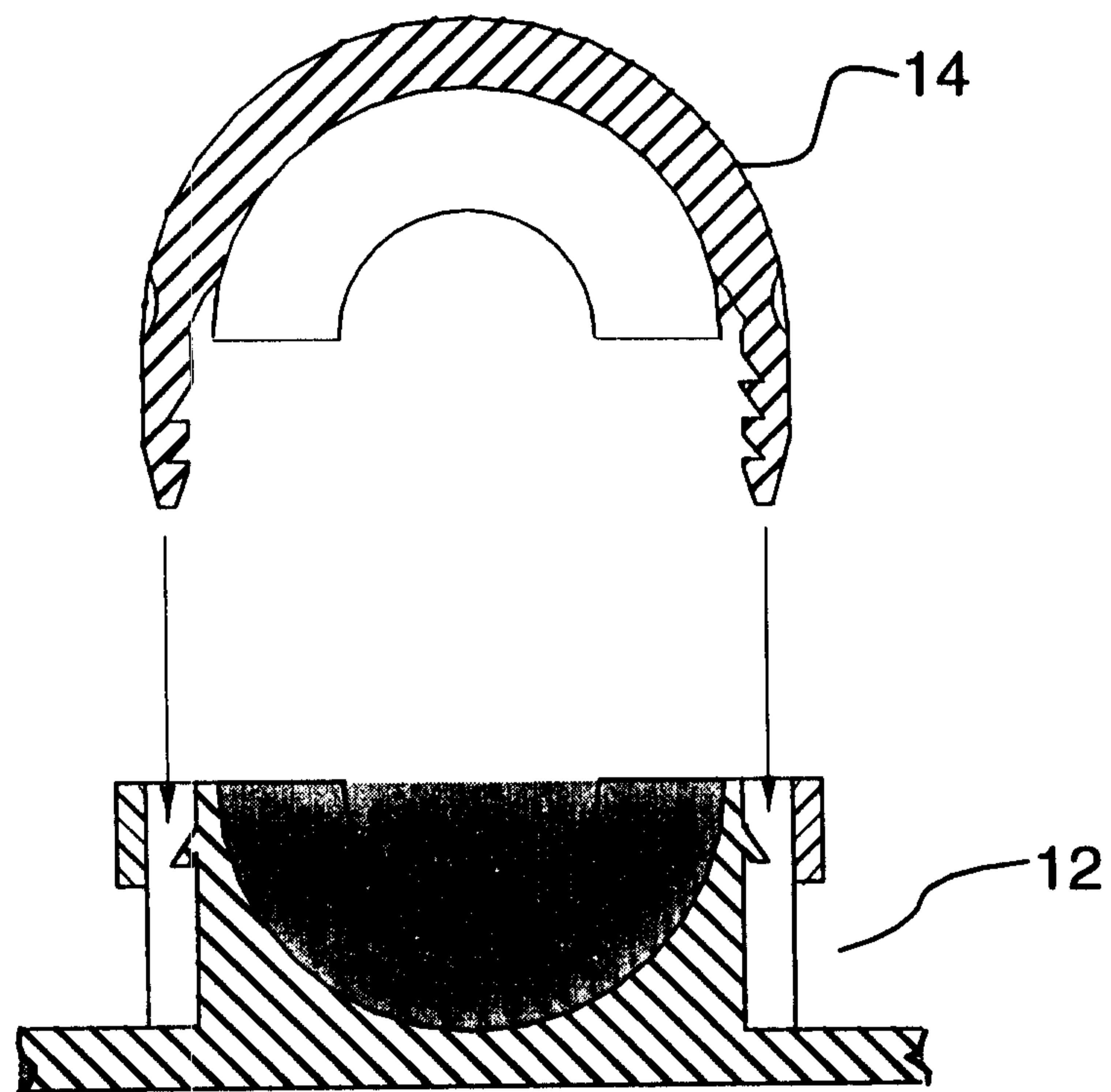

FIG.13.A

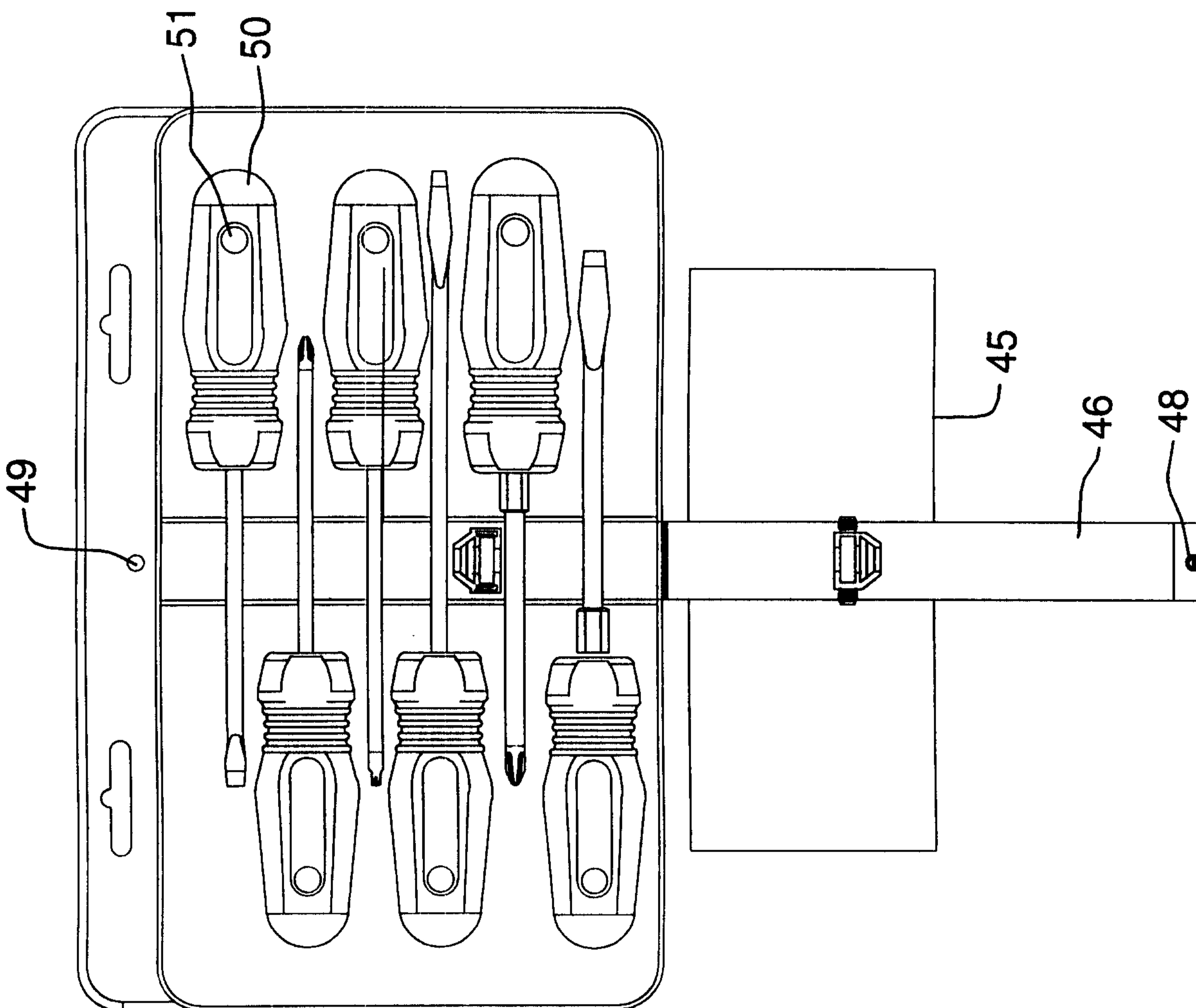

FIG. 14

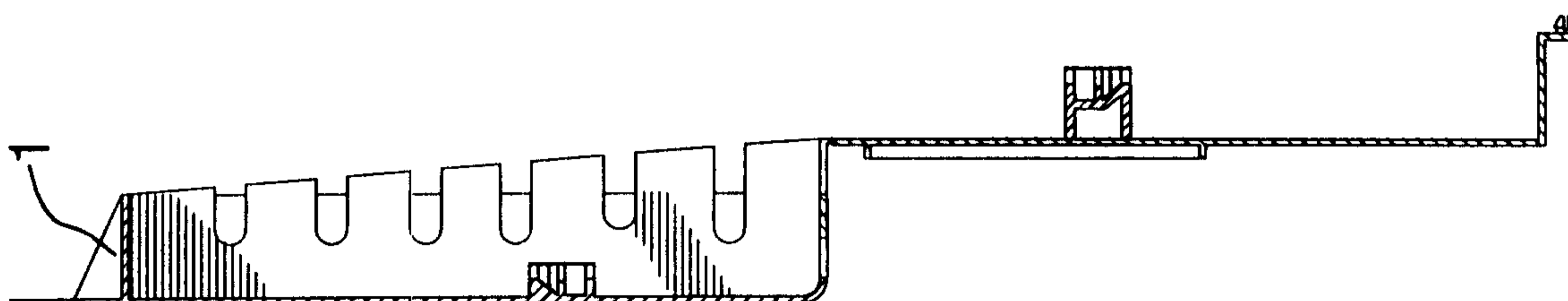

FIG. 15

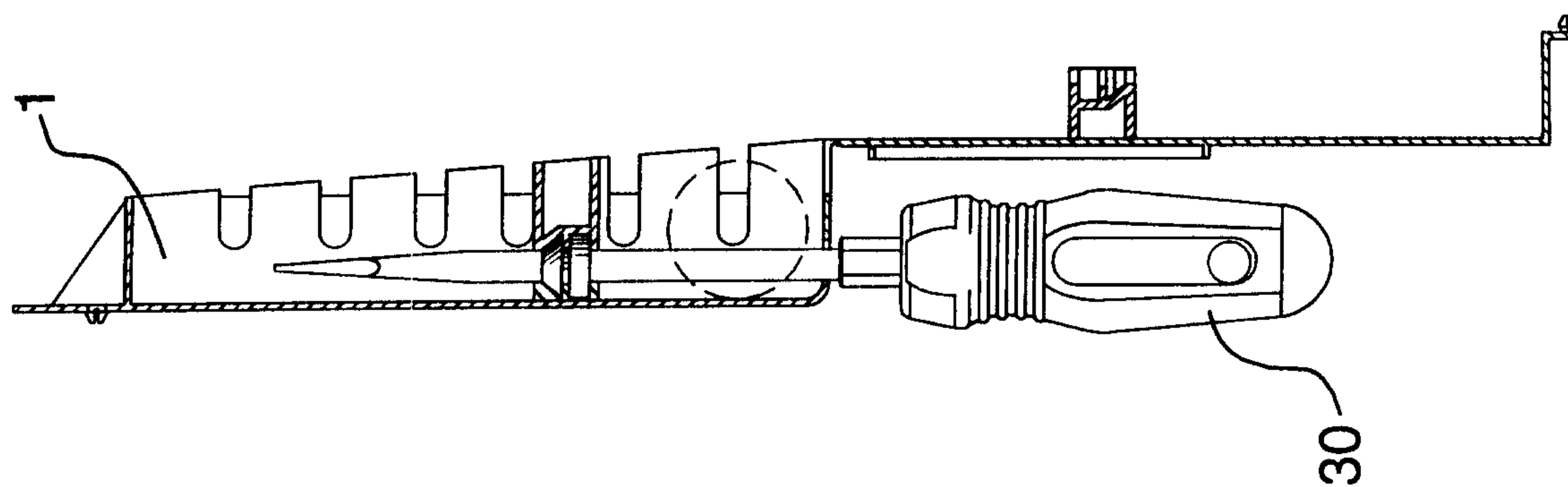

FIG. 16

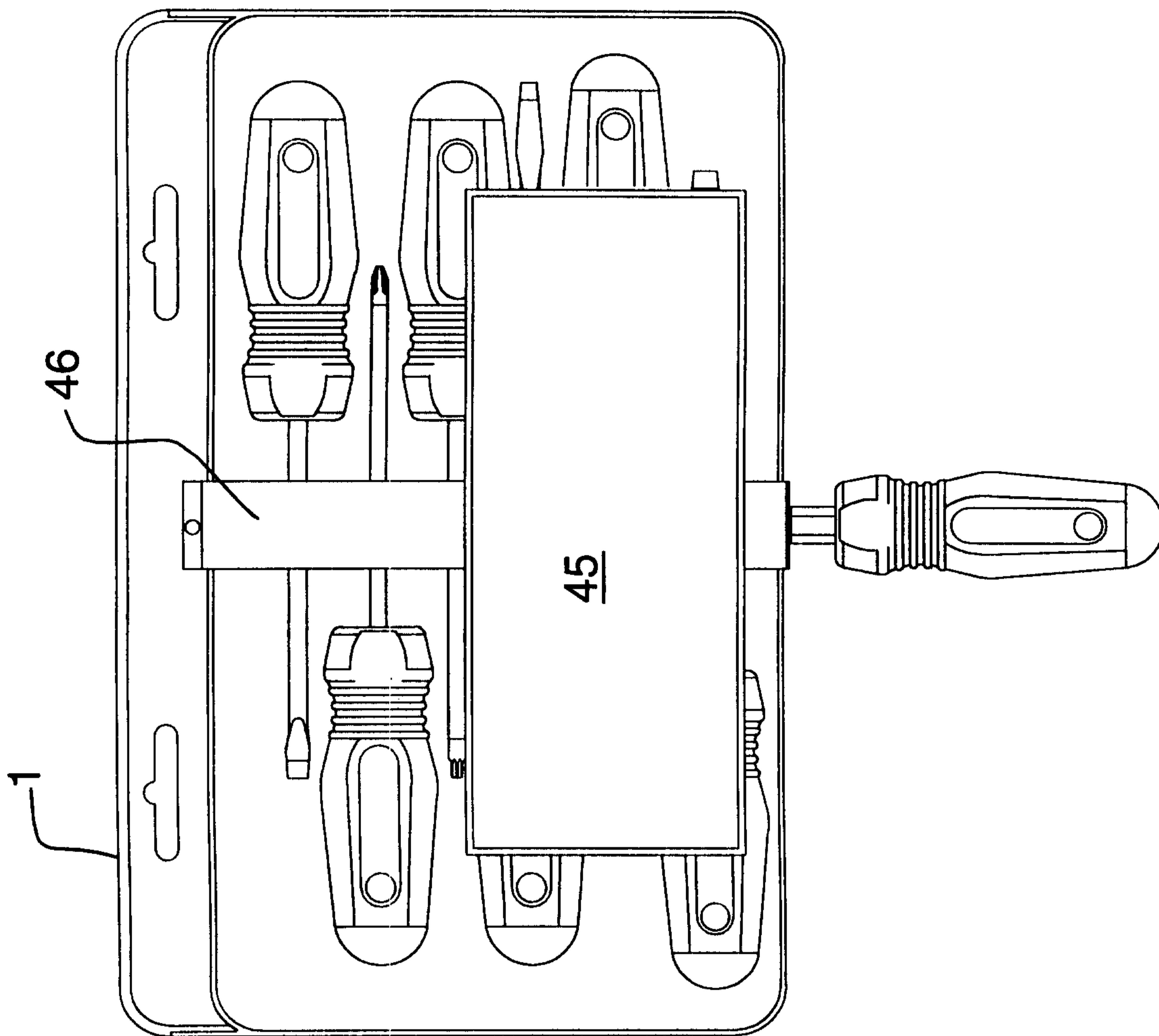

FIG.17

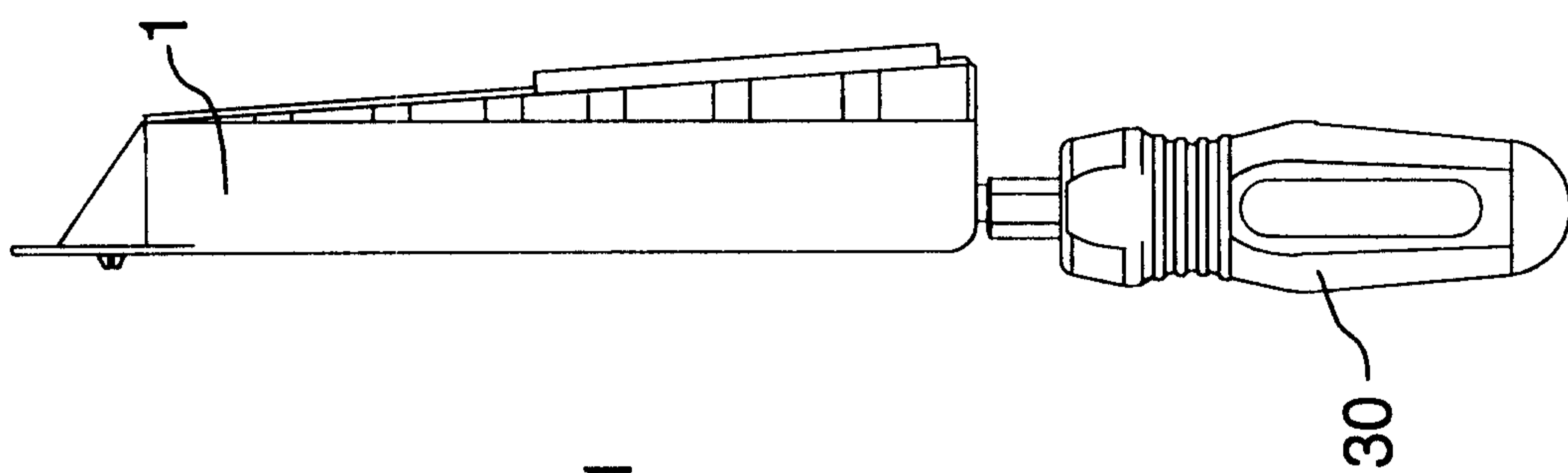

FIG.18

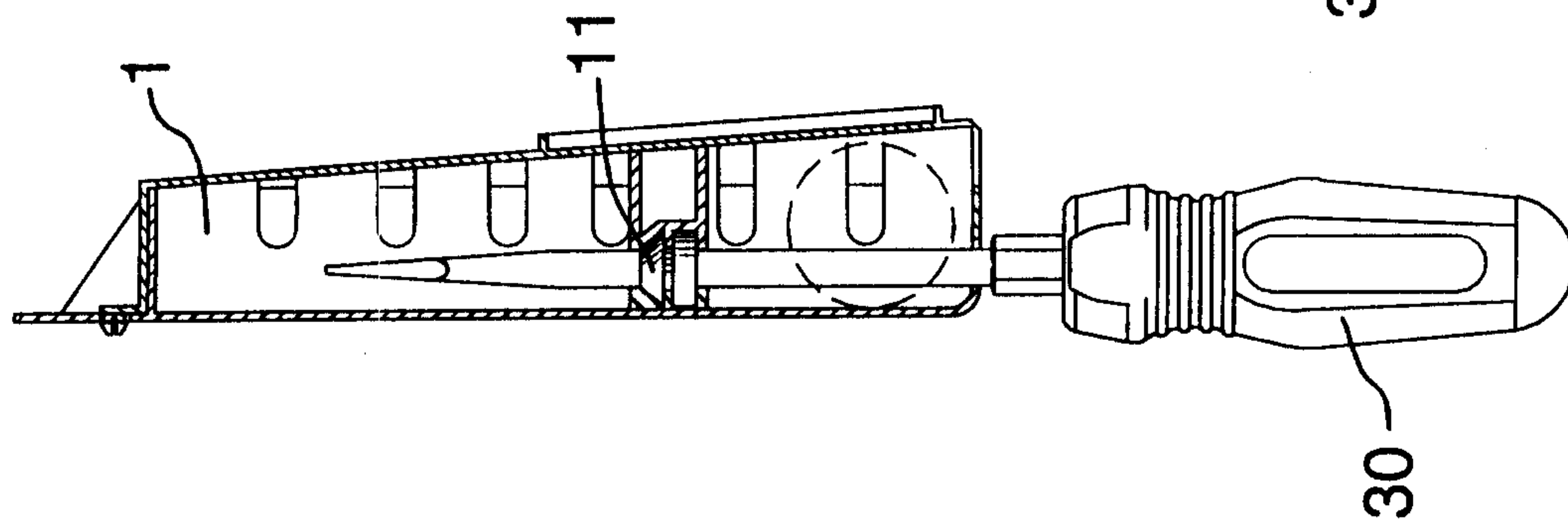

FIG.19

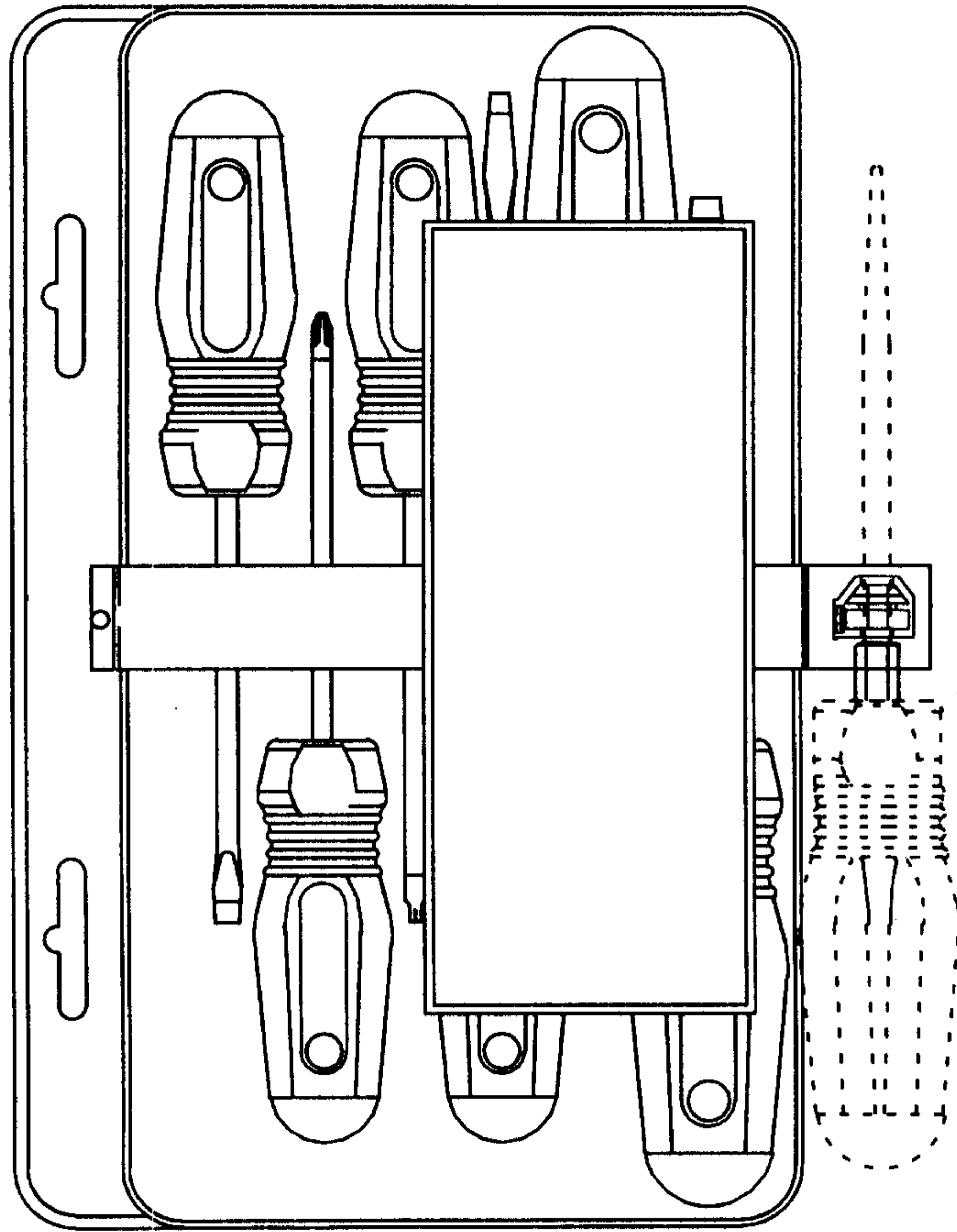

FIG.20

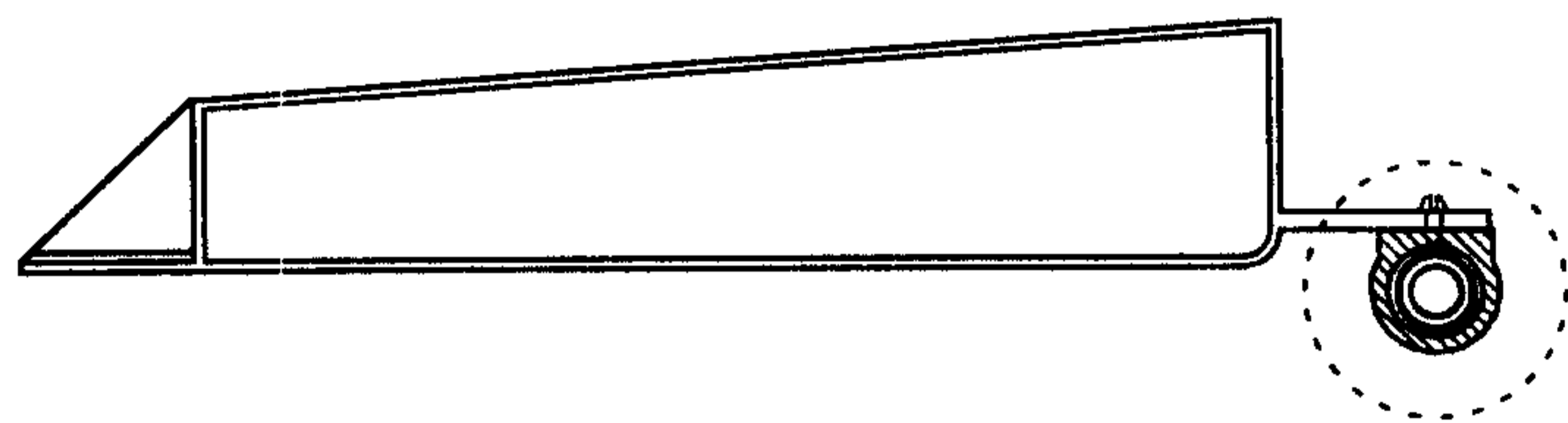

FIG.21

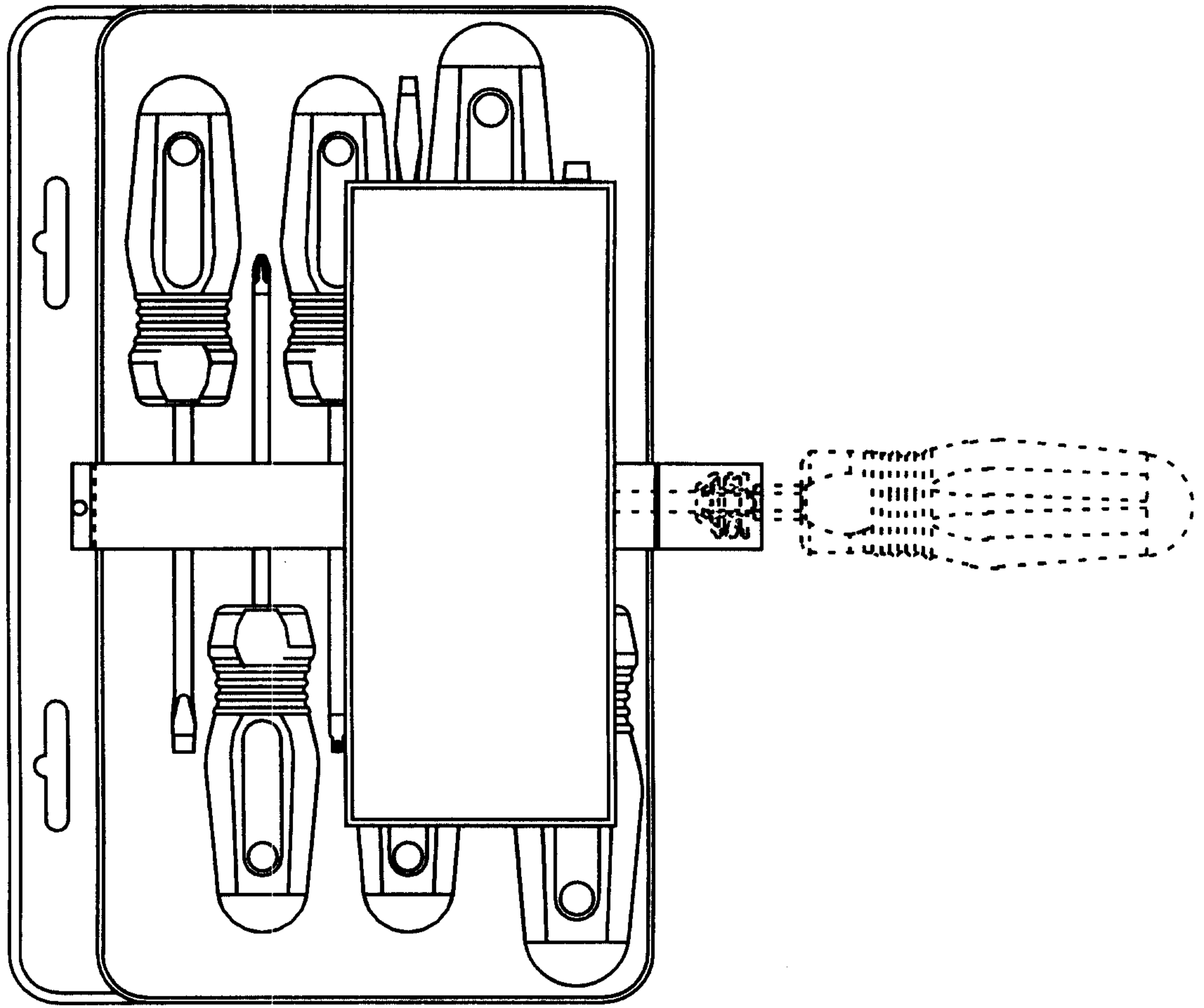

FIG. 22

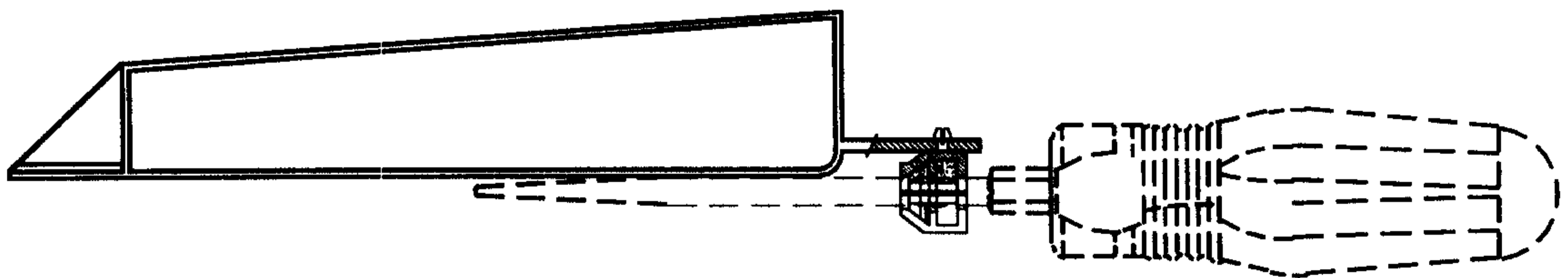

FIG. 23

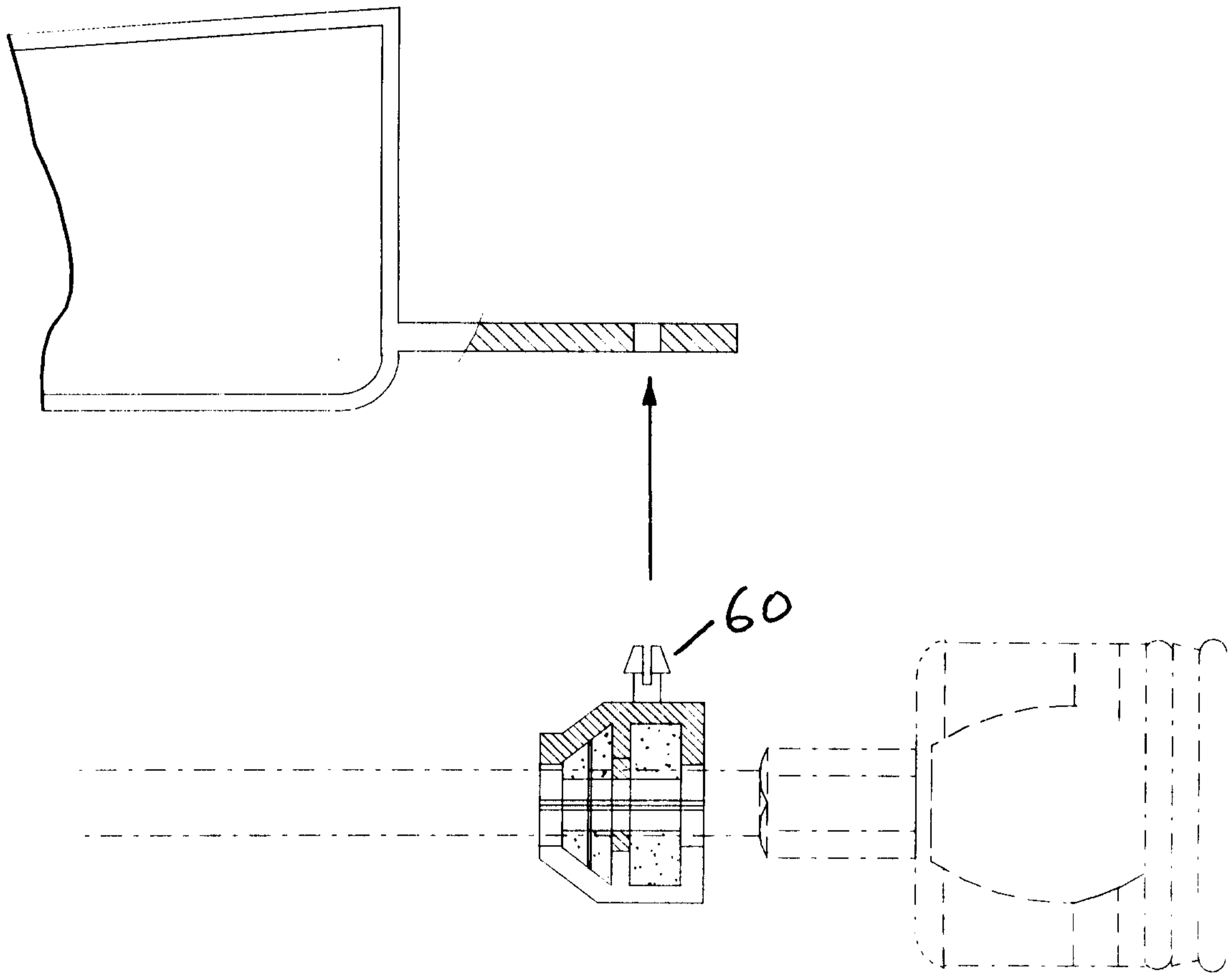
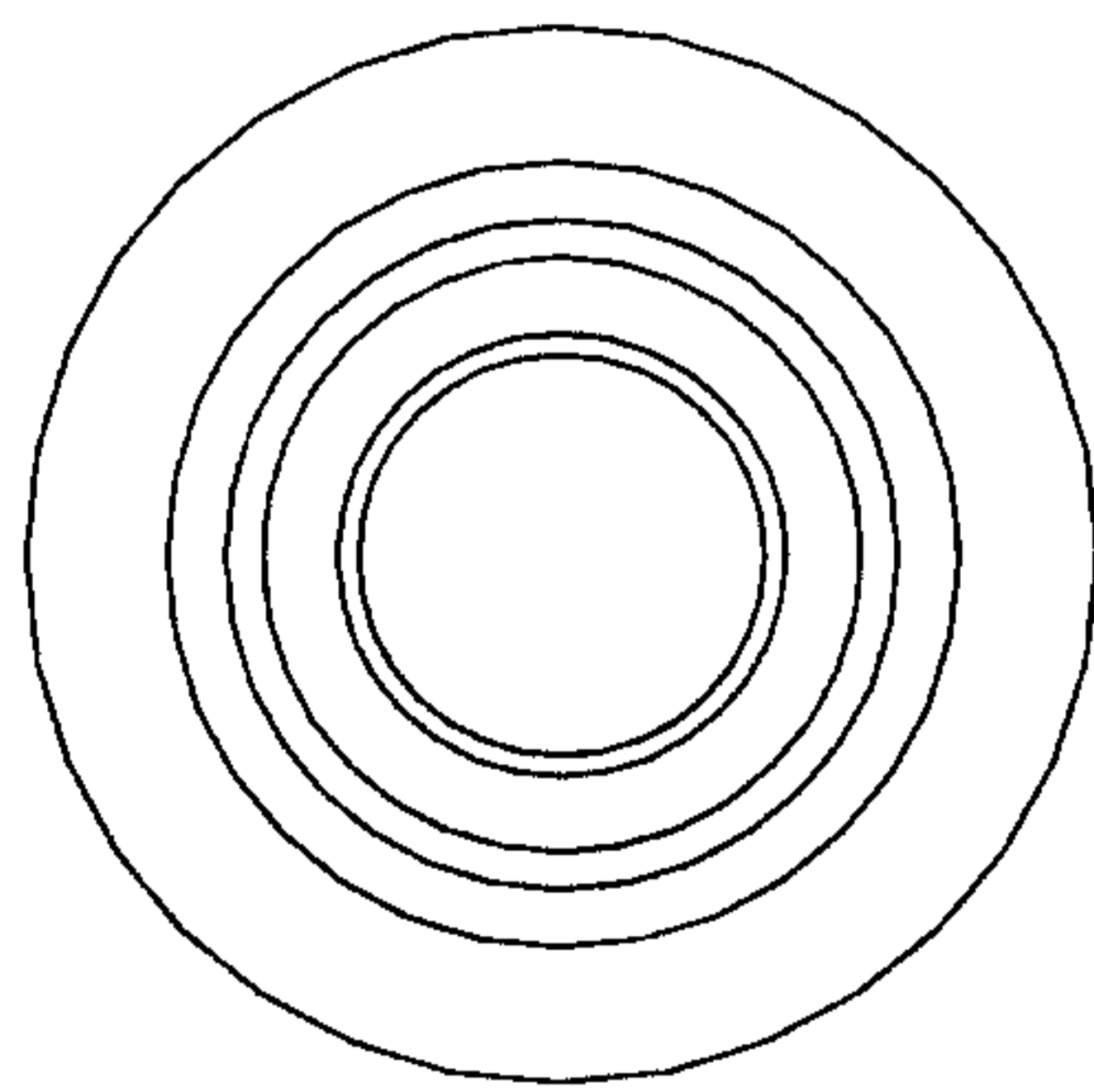
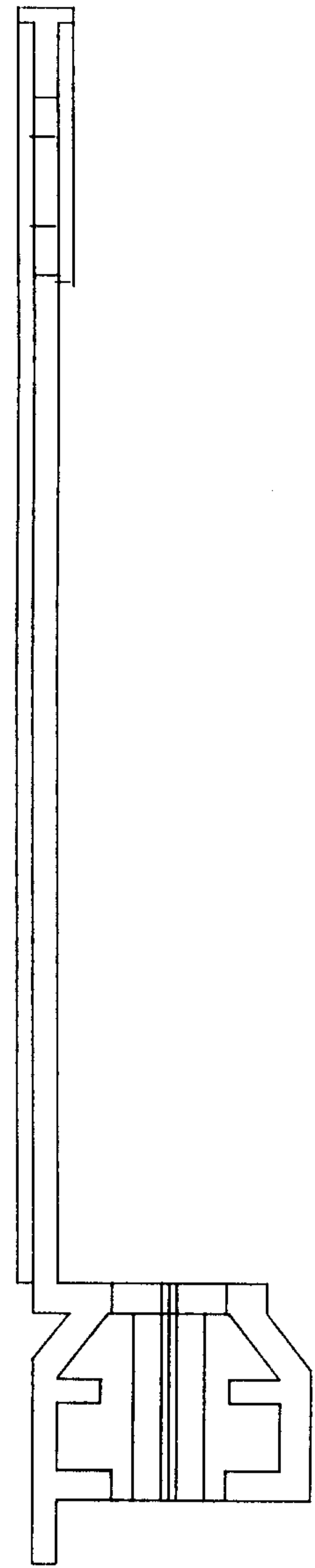
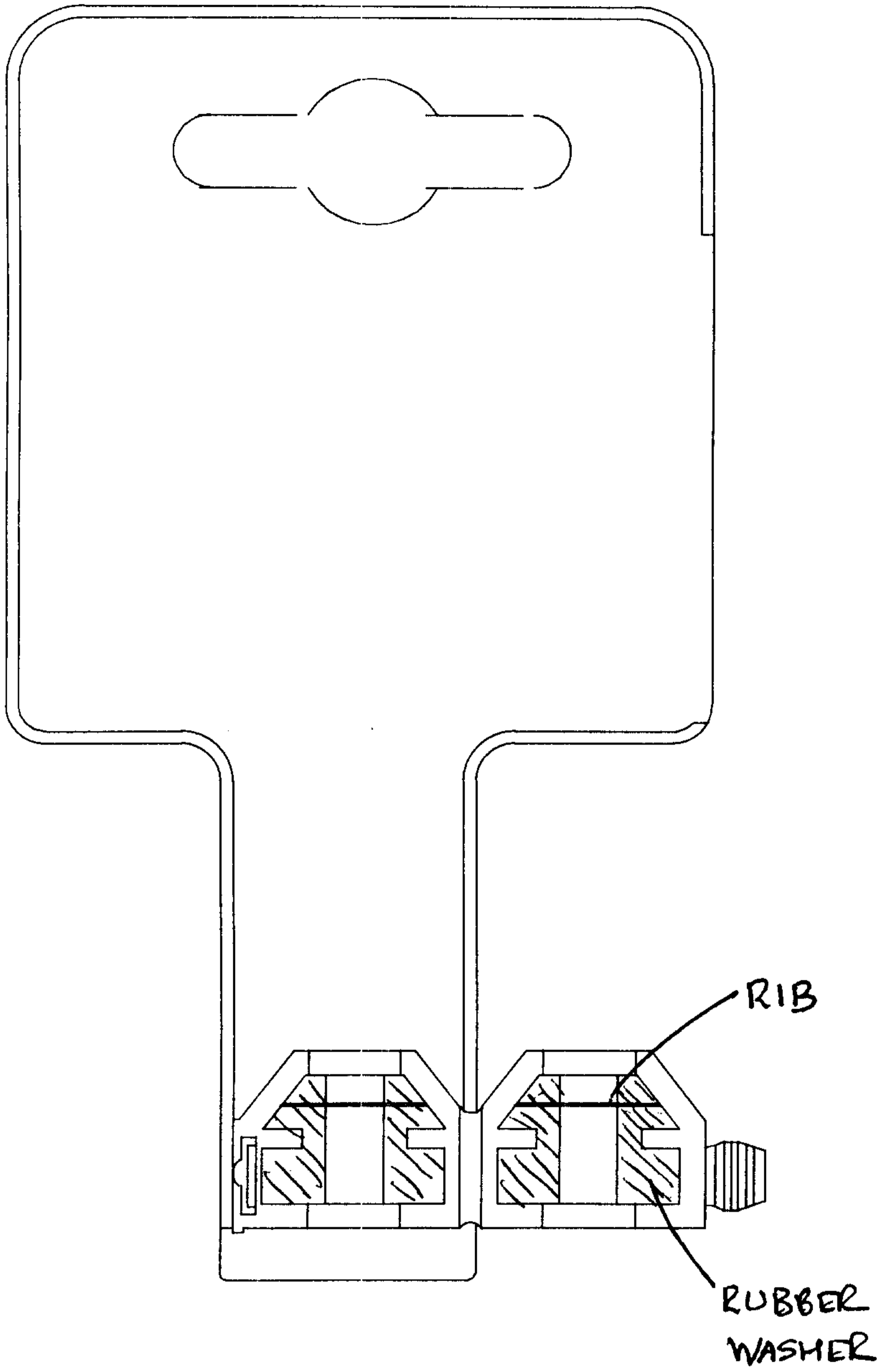

FIG.24



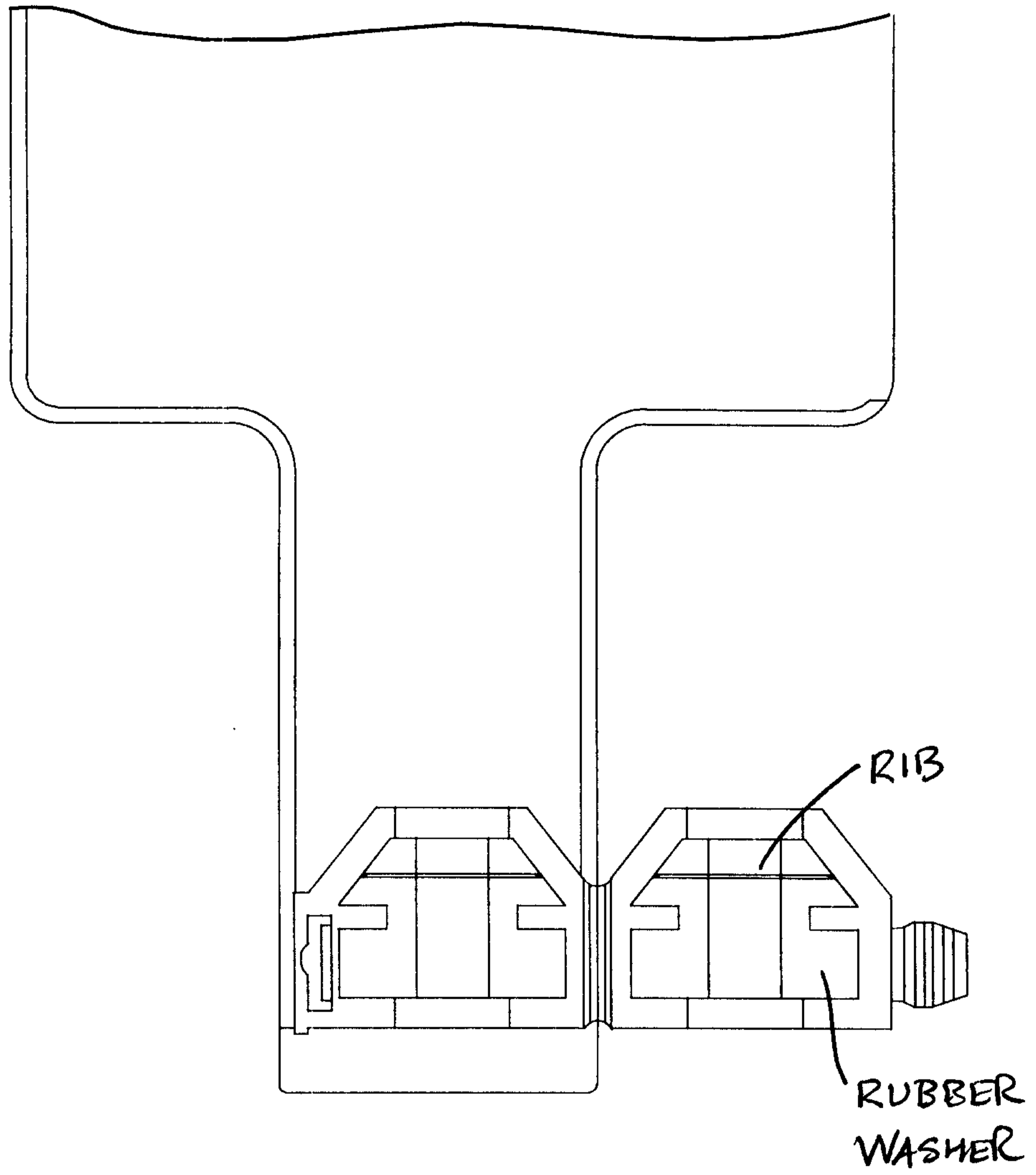

FIG.28

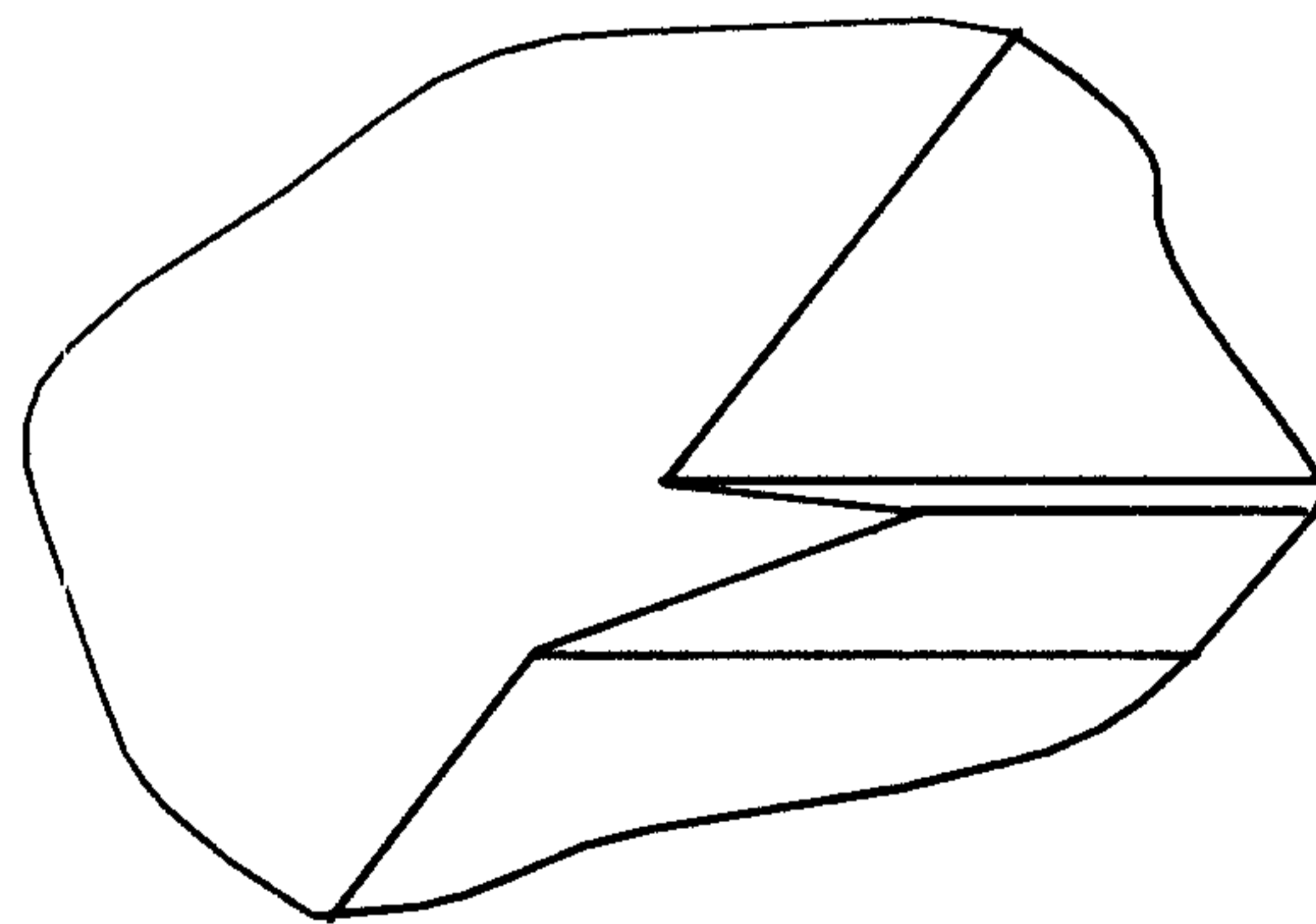

FIG.29 (RIB DETAIL)

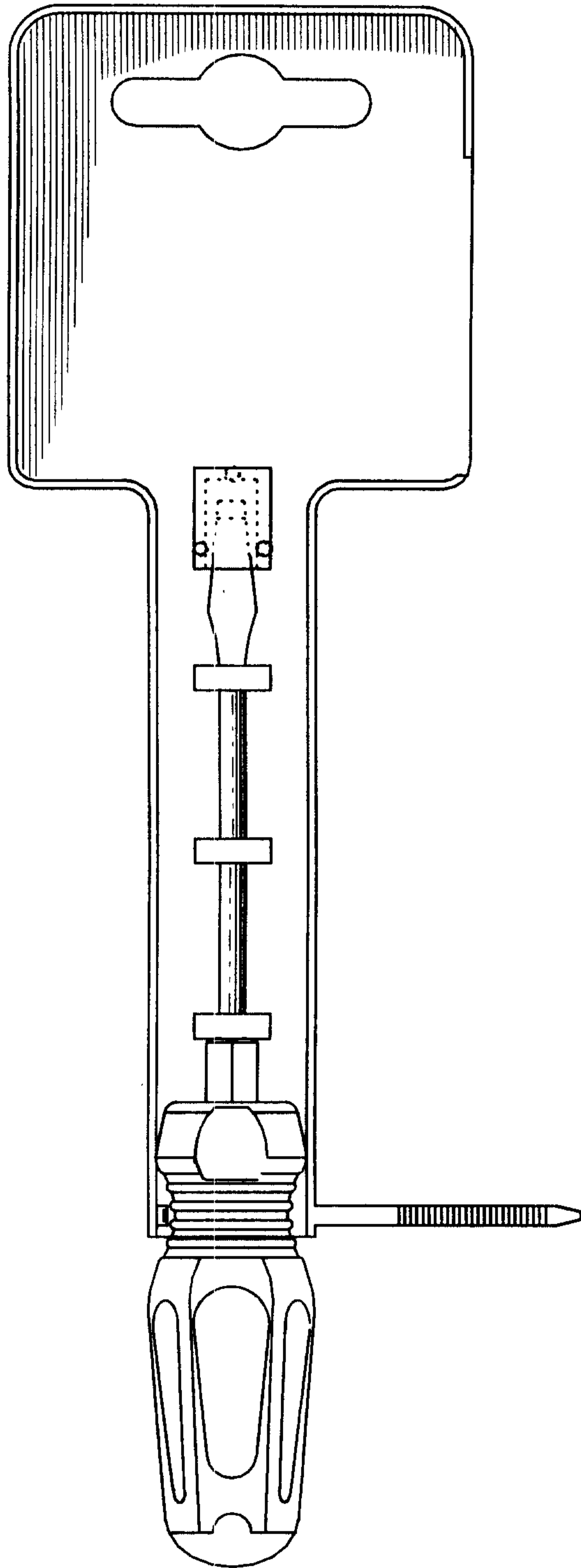

FIG. 30

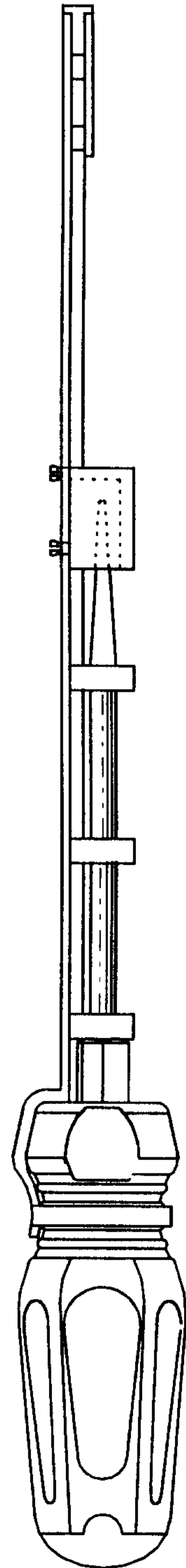

FIG. 31

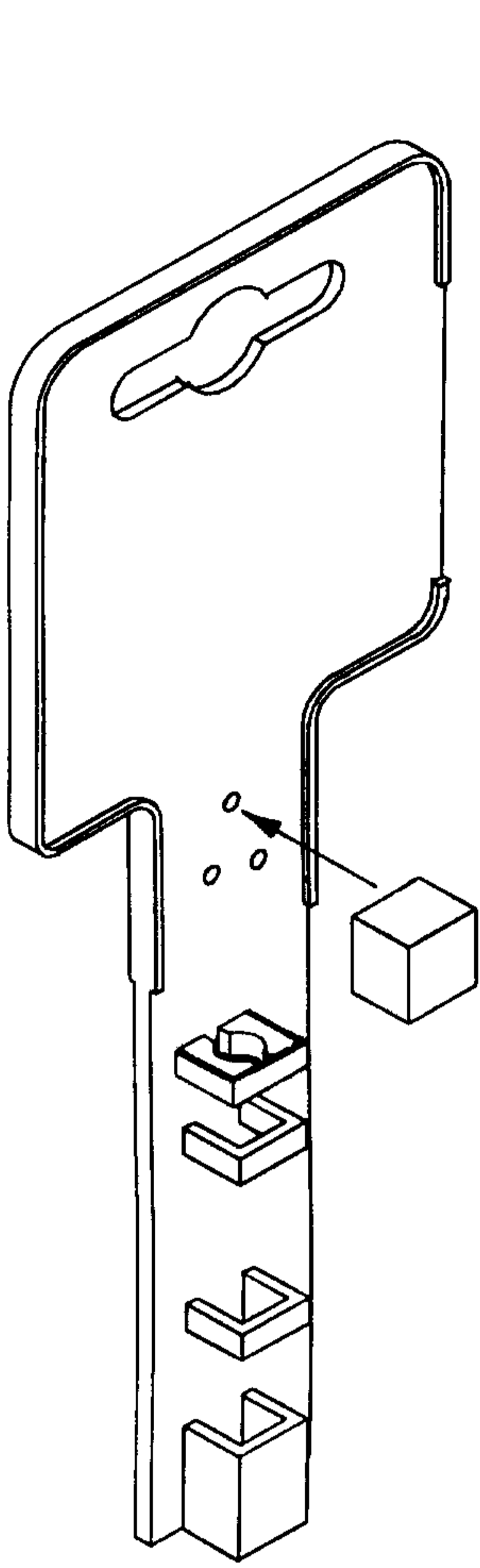

FIG. 32

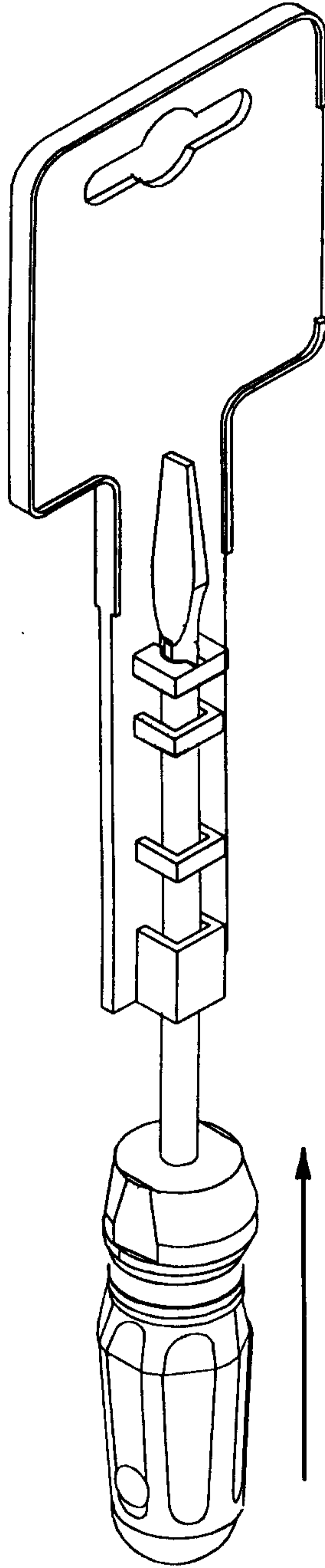

FIG. 33

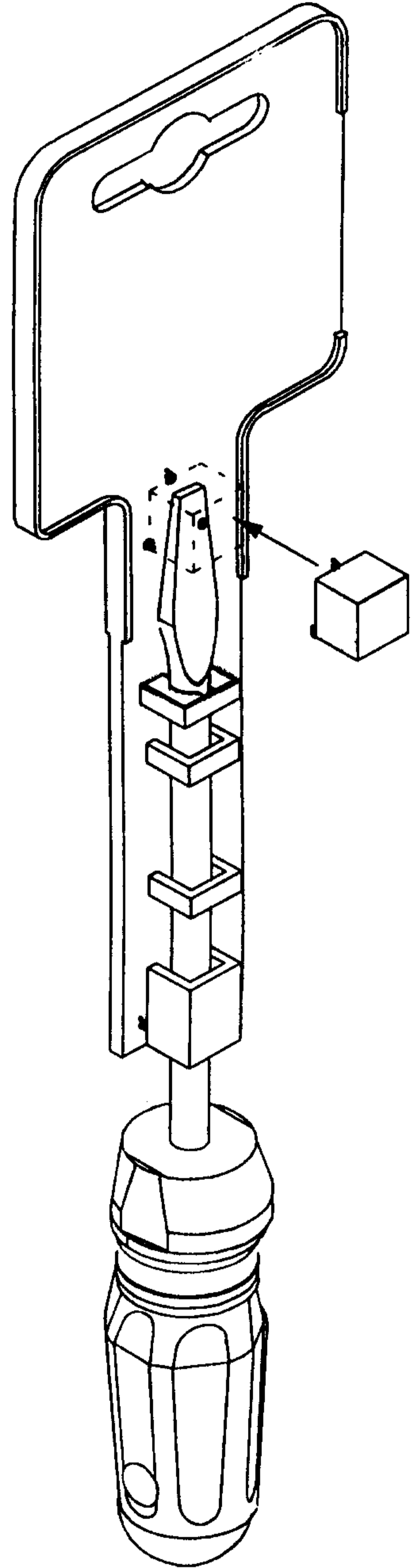

FIG. 34

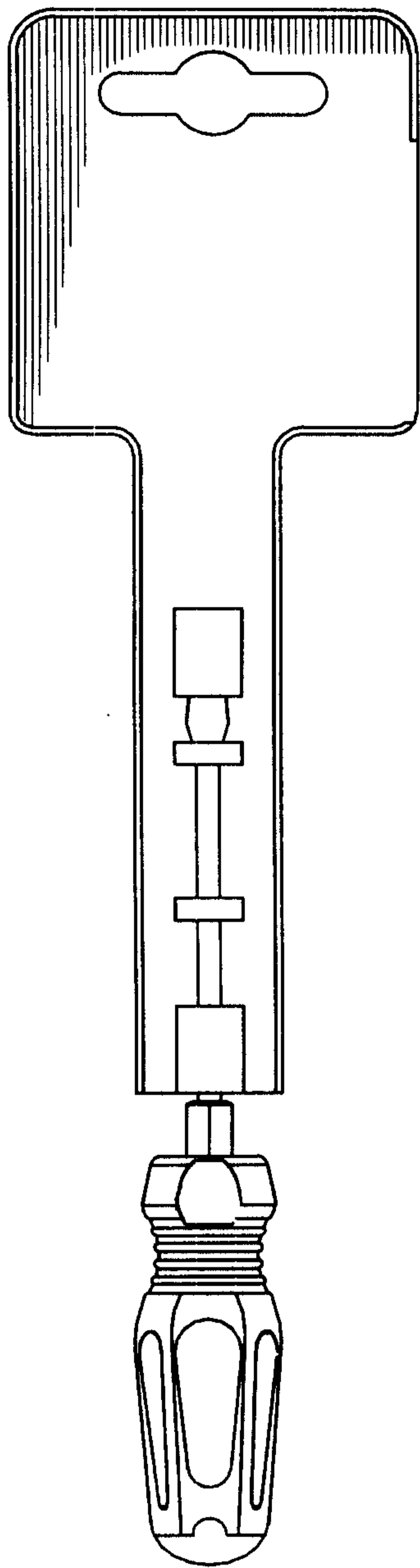

FIG. 35

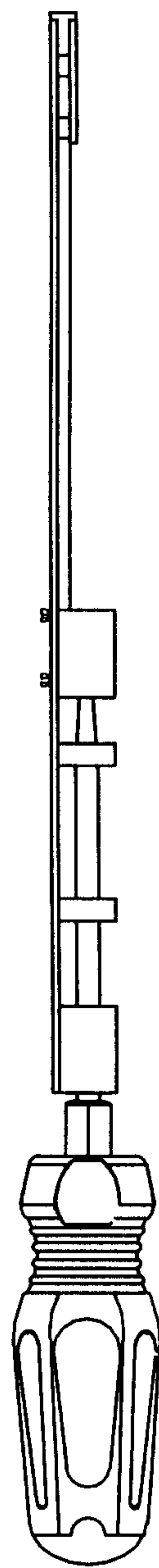

FIG. 36

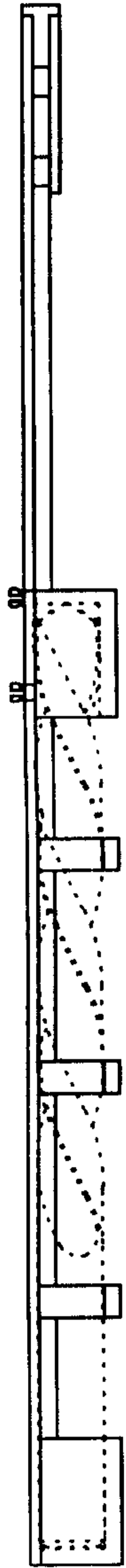

FIG. 38

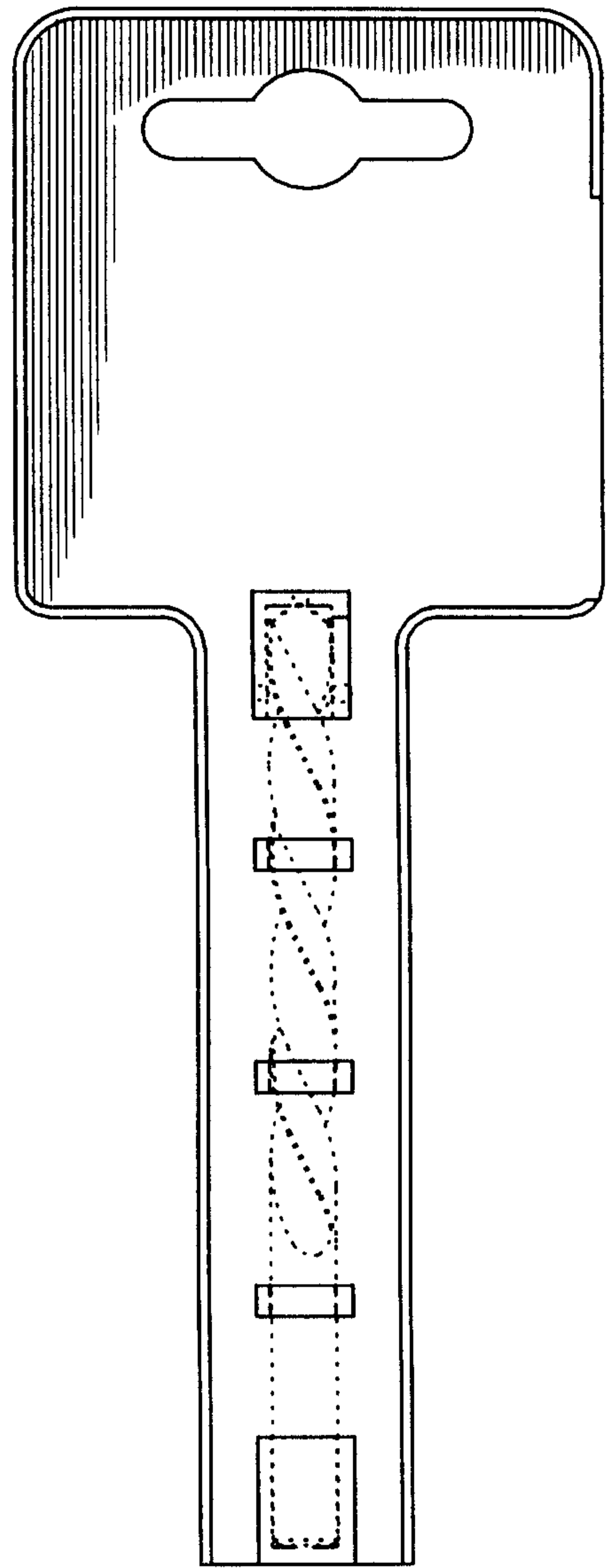

FIG. 37