

(19) World Intellectual Property Organization
International Bureau



(43) International Publication Date
27 October 2011 (27.10.2011)

PCT

(10) International Publication Number
WO 2011/133763 A3

- (51) International Patent Classification:
G11C 11/413 (2006.01) G11C 5/14 (2006.01)
- (21) International Application Number:
PCT/US2011/033417
- (22) International Filing Date:
21 April 2011 (21.04.2011)
- (25) Filing Language: English
- (26) Publication Language: English
- (30) Priority Data:
12/764,426 21 April 2010 (21.04.2010) US
- (63) Related by continuation (CON) or continuation-in-part (CIP) to earlier application:
US 12/764,426 (CON)
Filed on 21 April 2010 (21.04.2010)
- (71) Applicant (for all designated States except US): TEXAS INSTRUMENTS INCORPORATED [US/US]; P.O. Box 655474, Mail Station 3999, Dallas, TX 75265-5474 (US).
- (71) Applicant (for JP only): TEXAS INSTRUMENTS JAPAN LIMITED [JP/JP]; 24-1, Nishi-Shinjuku 6-chome, Shinjuku-ku Tokyo, 160-8366 (JP).
- (72) Inventor; and
- (75) Inventor/Applicant (for US only): SESHADRI, Anand [US/US]; 2702 West Prairie Creek Drive, Richardson, TX 75080 (US).

- (74) Agents: FRANZ, Warren, L. et al.; Texas Instruments Incorporated, Deputy General Patent Counsel, P.O. Box 655474, Mail Station 3999, Dallas, TX 75265-5474 (US).
- (81) Designated States (unless otherwise indicated, for every kind of national protection available): AE, AG, AL, AM, AO, AT, AU, AZ, BA, BB, BG, BH, BR, BW, BY, BZ, CA, CH, CL, CN, CO, CR, CU, CZ, DE, DK, DM, DO, DZ, EC, EE, EG, ES, FI, GB, GD, GE, GH, GM, GT, HN, HR, HU, ID, IL, IN, IS, JP, KE, KG, KM, KN, KP, KR, KZ, LA, LC, LK, LR, LS, LT, LU, LY, MA, MD, ME, MG, MK, MN, MW, MX, MY, MZ, NA, NG, NI, NO, NZ, OM, PE, PG, PH, PL, PT, RO, RS, RU, SC, SD, SE, SG, SK, SL, SM, ST, SV, SY, TH, TJ, TM, TN, TR, TT, TZ, UA, UG, US, UZ, VC, VN, ZA, ZM, ZW.
- (84) Designated States (unless otherwise indicated, for every kind of regional protection available): ARIPO (BW, GH, GM, KE, LR, LS, MW, MZ, NA, SD, SL, SZ, TZ, UG, ZM, ZW), Eurasian (AM, AZ, BY, KG, KZ, MD, RU, TJ, TM), European (AL, AT, BE, BG, CH, CY, CZ, DE, DK, EE, ES, FI, FR, GB, GR, HR, HU, IE, IS, IT, LT, LU, LV, MC, MK, MT, NL, NO, PL, PT, RO, RS, SE, SI, SK, SM, TR), OAPI (BF, BJ, CF, CG, CI, CM, GA, GN, GQ, GW, ML, MR, NE, SN, TD, TG).

Declarations under Rule 4.17:

- as to applicant's entitlement to apply for and be granted a patent (Rule 4.17(ii))
- as to the applicant's entitlement to claim the priority of the earlier application (Rule 4.17(iii))

[Continued on next page]

(54) Title: RETAIN-TILL-ACCESSED (RTA) POWER SAVING MODE IN HIGH PERFORMANCE STATIC MEMORIES

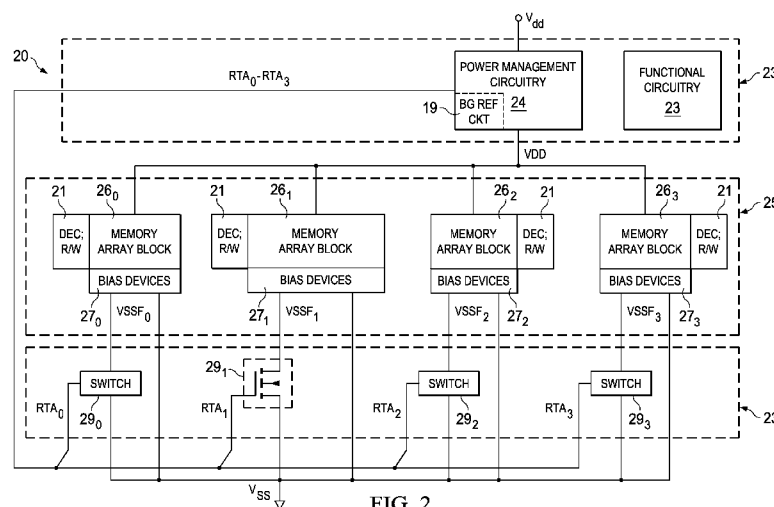

FIG. 2

(57) Abstract: Bias circuitry for a static random-access memory (SRAM) with a retain-till-accessed (RTA) mode. The memory is constructed of multiple memory array blocks (26), each including SRAM cells of the 8-T or 10-T type, with separate read and write data paths. Bias devices (27) are included within each memory array block (26), for example associated with individual columns, and connected between a reference voltage node for cross-coupled inverters in each memory cell in the associated column or columns, and a ground node. In a normal operating mode, a switch transistor (29) connected in parallel with the bias devices is turned on, so that the ground voltage biases the cross-coupled inverters in each cell. In the RTA mode, the switch transistors are turned off, allowing the bias devices to raise the reference bias to the cross-coupled inverters, reducing power consumed by the cells in that mode.

WO 2011/133763 A3



Published:

(88) Date of publication of the international search report:

9 February 2012

- *with international search report (Art. 21(3))*
- *before the expiration of the time limit for amending the claims and to be republished in the event of receipt of amendments (Rule 48.2(h))*

INTERNATIONAL SEARCH REPORT

International application No.
PCT/US2011/033417**A. CLASSIFICATION OF SUBJECT MATTER***G11C 11/413(2006.01)i, G11C 5/14(2006.01)i*

According to International Patent Classification (IPC) or to both national classification and IPC

B. FIELDS SEARCHED

Minimum documentation searched (classification system followed by classification symbols)

G11C 11/413; G11C 7/00; G11C 11/4193; G11C 11/41; H01L 21/8244; G11C 11/00

Documentation searched other than minimum documentation to the extent that such documents are included in the fields searched

Korean utility models and applications for utility models
Japanese utility models and applications for utility models

Electronic data base consulted during the international search (name of data base and, where practicable, search terms used)

eKOMPASS(KIPO internal) & Keywords: SRAM, static memory, Vss, ground, RTA, bias, read buffer

C. DOCUMENTS CONSIDERED TO BE RELEVANT

Category*	Citation of document, with indication, where appropriate, of the relevant passages	Relevant to claim No.
Y A	US 2007-0279966 A1 (HOUSTON, THEODORE WARREN) 06 December 2007 See paragraphs [0064] - [0068], [0076] - [0080], [0085] - [0086]; figures 2B, 2C, 2D.	1-6,9-11,16 7-8,12-15,17
Y A	US 2006-0002223 A1 (SONG, TAE-JOONG et al.) 05 January 2006 See paragraphs [0038] - [0040]; figure 5.	1-6,9-11,16 7-8,12-15,17
A	KR 10-0662215 B1 (MIN, KYEONG SIK) 28 December 2006 See page 5, lines 15 - 36; figure 6.	1-17
A	JP 2009-076169 A (FUJITSU MICROELECTRONICS LTD.) 09 April 2009 See paragraphs [0004] - [0117].	1-17
A	JP 2008-090958 A (TOSHIBA CORP.) 17 April 2008 See paragraphs [0072] - [0084].	1-17

 Further documents are listed in the continuation of Box C. See patent family annex.

* Special categories of cited documents:

"A" document defining the general state of the art which is not considered to be of particular relevance

"E" earlier application or patent but published on or after the international filing date

"L" document which may throw doubts on priority claim(s) or which is cited to establish the publication date of citation or other special reason (as specified)

"O" document referring to an oral disclosure, use, exhibition or other means

"P" document published prior to the international filing date but later than the priority date claimed

"T" later document published after the international filing date or priority date and not in conflict with the application but cited to understand the principle or theory underlying the invention

"X" document of particular relevance; the claimed invention cannot be considered novel or cannot be considered to involve an inventive step when the document is taken alone

"Y" document of particular relevance; the claimed invention cannot be considered to involve an inventive step when the document is combined with one or more other such documents, such combination being obvious to a person skilled in the art

"&" document member of the same patent family

Date of the actual completion of the international search

17 DECEMBER 2011 (17.12.2011)

Date of mailing of the international search report

19 DECEMBER 2011 (19.12.2011)

Name and mailing address of the ISA/KR

Korean Intellectual Property Office
Government Complex-Daejeon, 189 Cheongsu-ro,
Seo-gu, Daejeon 302-701, Republic of Korea

Facsimile No. 82-42-472-7140

Authorized officer

JANG Ho Keun

Telephone No. 82-42-481-8187



INTERNATIONAL SEARCH REPORT

Information on patent family members

International application No.

PCT/US2011/033417

Patent document cited in search report	Publication date	Patent family member(s)	Publication date
US 2007-0279966 A1	06.12.2007	EP 1931104 A1	11.06.2008
		EP 1931104 B1	17.06.2009
		JP 2008-148313 A	26.06.2008
		US 2008-0137598 A1	12.06.2008
		US 2008-0247221 A1	09.10.2008
		US 2010-0259973 A1	14.10.2010
		US 7400523 B2	15.07.2008
		US 7742326 B2	22.06.2010
		US 7953123 B2	31.05.2011
		US 2006-0002223 A1	05.01.2006
CN 1725373 A	25.01.2006		
CN 1725373 C0	25.01.2006		
KR 10-0604876 B1	31.07.2006		
TW 261250 B	01.09.2006		
US 7110317 B2	19.09.2006		
KR 10-0662215 B1	28.12.2006	None	
JP 2009-076169 A	09.04.2009	None	
JP 2008-090958 A	17.04.2008	AU 2006-270071 A1	25.01.2007
		CA 2615403 A1	25.01.2007
		CN 101495184 A	29.07.2009
		EP 1904069 A2	02.04.2008
		JP 2009-508807 A	05.03.2009
		KR 10-2008-0044840 A	21.05.2008
		US 2007-0021408 A1	25.01.2007
		US 2008-0207595 A9	28.08.2008
		US 2008-0253170 A1	16.10.2008
		US 2009-0118260 A1	07.05.2009
		US 2010-0073996 A1	25.03.2010
		US 2011-0046114 A1	24.02.2011
		US 7643331 B2	05.01.2010
		US 7956050 B2	07.06.2011
		US 7983072 B2	19.07.2011
		WO 2007-011820 A2	25.01.2007
		WO 2007-011820 A3	25.01.2007